



सत्यमेव जयते



GOVERNMENT OF INDIA

CENTRAL PUBLIC WORKS DEPARTMENT

# SPECIFICATIONS

(VOL. 2)

2019



**Director General, CPWD, New Delhi**



**GOVERNMENT OF INDIA**

**CENTRAL PUBLIC WORKS DEPARTMENT**

# **SPECIFICATIONS**

**(VOL. 2)**

**2019**



Published under the Authority of Director General, CPWD, New Delhi

© All rights reserved. No part of this publication may be reproduced in any form or by any means, electronic or mechanical, including photocopying, recording on any information storage and retrieval system, without permission, in writing, from the Director General, CPWD, New Delhi. Photocopying of this book is strictly prohibited.

**For feed back and suggestions, please contact SE(TAS), CPWD, Room No. 418, "A" Wing, Nirman Bhawan, New Delhi. Tel. No. 011-23062339, Email: delsetascsq.cpwd@nic.in**

**A GOVERNMENT OF INDIA PUBLICATION**

Published by  
**DIRECTOR GENERAL**  
CPWD, Nirman Bhawan, New Delhi - 110011

Printed & Distributed by  
**JAIN BOOK AGENCY (CENTRAL)**  
4574/15, 2nd Floor, Padamchand Marg,  
Near Happy School, Daryaganj, New Delhi-110002  
Phone : 011- 43513689, 43513570  
Mob: 9667274446, 9810666810  
E-mail : thakur@jainbookagency.com

&

Marketed by

**JAIN BOOK AGENCY**

Authorised Dealers of Govt. Publications  
C-9, Connaught Place, New Delhi-110001  
Phones : 011- 44556677, 23416390 upto 94  
E-mail : cp@jainbookagency.com  
Website : www.jainbookagency.com

**JAIN BOOK DEPOT**

C - 4, Opp. PVR Plaza, Post Box. No. 51,  
Connaught Place, New Delhi-110001 (India)  
Phone : 011- 23416101 / 02 / 03  
E-mail : sales@jainbookdepot.com

**JAIN BOOK AGENCY (SOUTHEND)**

1, Aurobindo Place Market,  
Hauz Khas, New Delhi-110016  
Phone : 011- 41755666  
E-mail : sales@jainbookagency.com  
Website : www.jainbookagency.com

**JAIN BOOK AGENCY (GURGAON)**

19, Central Plaza Mall, Sector 53,  
Golf Course Road,  
Gurgaon 122002 Haryana  
Phone : 0124- 4042665  
Mobile : 9810666810

**JAIN BOOK AGENCY (INTERNATIONAL)**

RA- 11, Sector- 126,  
Opp. Gate No. 2A of Amity University,  
Noida  
Mobile. : 9210080580

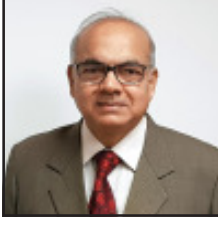
**JAIN BOOK AGENCY (GREATER NOIDA)**

11 Jagat farm Complex  
Gama Sector Market  
Near OBC Bank  
Greater Noida  
Phone : 0120-4206655

**Also available at**

All Leading Booksellers & Authorised Govt. Dealers In India

Price : Rs. 2500/- (for both volumes) excluding postage and forwarding charges etc.



**PRABHAKAR SINGH**  
Director General



सत्यमेव जयते  
भारत सरकार  
Government of India



केन्द्रीय लोक निर्माण विभाग  
निर्माण भवन, नई दिल्ली 110011  
Central Public Works Department  
Nirman Bhawan, New Delhi- 110011  
Tel : 23062556 / 1317, Fax : 23061884  
E-Mail : cpwd\_dgw@nic.in

## FOREWORD

The CPWD Specifications being published by CPWD from time to time are very comprehensive and useful in execution of works and are used as guide by a number of Engineering Departments, Public Sector Undertakings, Architects and Builders. These specifications not only give the standards for building materials but also serve as guidelines for execution of works, measurements and rates.

The CPWD Specifications were first compiled in 1950. Subsequently, these specifications have been revised in the years 1962, 1967, 1977, 1996 and 2009

Many new items and construction technologies, which are used in various CPWD works and projects have been incorporated in Delhi Schedule of Rates of CPWD. Some items have become obsolete over a period of time and are not in use. Further, there were no specifications for Rain Water Harvesting & Tubewells, Conservation of Heritage Buildings, Structural Glazing Aluminium Composite Panel and New Technologies & Materials. CPWD Specifications have been accordingly modified/ revised and updated to incorporate the above changes.

The revised/updated specifications are being published in two volumes.

I wish to place on record the effective coordination on the part of **Dr. K. M. Soni, ADG (Tech.)** and the technical inputs and the efforts by **Sh. M. K. Mallick, CE (CSQ)**, **Sh. Divakar Agrawal, SE(TAS)**, **Sh. Satya Narain Jaiswal, EE(TAS-I)**, **Sh. Moti Lal Prasad (TAS-II)**, **Sh. D.S. Adhikari, AE(QA)**, **Sh. Naveenkumar P, JE** and **Sh. Chalapaka Ramaraju, JE** and all others officers of CSQ in finalizing these specifications.

I am sure that these Specifications will be useful to all concerned in the building industry in general and CPWD in particular.

  
(Prabhakar Singh)

Place: New Delhi  
Dated: July 2019







**DR K.M. SONI**  
Additional Director General (Tech)



भारत सरकार  
Government of India



केन्द्रीय लोक निर्माण विभाग  
निर्माण भवन, नई दिल्ली 110011  
Central Public Works Department  
Nirman Bhawan, New Delhi- 110011

## PREFACE

- 1.0 CPWD Specifications, 2019 are the revised edition of existing CPWD Specifications.
- 2.0 CPWD Specifications, 2019 is published in two volumes as under:

| <b>Volume Number</b> | <b>Sub-head No.</b> | <b>Contents/ Chapters</b>       |
|----------------------|---------------------|---------------------------------|
| <b>1</b>             | 0.0                 | General                         |
|                      | 1.0                 | Carriage of Materials           |
|                      | 2.0                 | Earth Work                      |
|                      | 3.0                 | Mortars                         |
|                      | 4.0                 | Concrete Work                   |
|                      | 5.0                 | Reinforced Cement Concrete Work |
|                      | 6.0                 | Masonry work                    |
|                      | 7.0                 | Stone Work                      |
|                      | 8.0                 | Cladding work                   |
|                      | 9.0                 | Wood Work and PVC Work          |
|                      | 10.0                | Steel Work                      |
|                      | 11.0                | Flooring                        |
| 12.0                 | Roofing             |                                 |
| <b>2</b>             | 13.0                | Finishing                       |
|                      | 14.0                | Repairs to Buildings            |
|                      | 15.0                | Dismantling and Demolishing     |
|                      | 16.0                | Road Work                       |
|                      | 17.0                | Sanitary Installation           |
|                      | 18.0                | Water Supply                    |
|                      | 19.0                | Drainage                        |
|                      | 20.0                | Pile Work                       |
|                      | 21.0                | Aluminium Work                  |
|                      | 22.0                | Water Proofing                  |

|  |      |   |
|--|------|---|
|  | 23.0 | Rain Water Harvesting & Tubewells           |
|  | 24.0 | Conservation of Heritage Buildings          |
|  | 25.0 | Structural Glazing Aluminum Composite Panel |
|  | 26.0 | New Technologies and Materials              |

**3.0** CPWD Specifications, 2019 will replace existing CPWD Specifications, 2009 along with correction slips. The specifications of many items have been updated and improved by making them more comprehensive. Specifications of items, which have become obsolete over a period of time or are not in use, have been deleted. Many new items using new materials and latest technology have also been added.

**4.0** Specifications of dry work for speedier construction using prefabricated materials and pre-finished elements are included viz gypsum block walls, calcium silicate and non-asbestos cement board partitions, pre-finished counter tops for kitchen and washbasins, pre-moulded and pre-finished stone work in risers and treads of steps and window sills, dry stone cladding, sub-frames for windows, use of chemical and mechanical fasteners, laying of tiles in flooring and dado with polymer based adhesives etc.

**5.0** Specifications of Rain Water Harvesting & Tubewells, Conservation of Heritage Building, Structural Glazing Aluminium Composite Panel and New Technologies & Materials are incorporated for the first time.

**6.0** Sub-head wise salient features are as follows:

**6.1 Earth Work** : Specifications for filling with available fly ash and Earth (excluding rock) have been incorporated. The clause no 2.22 has been deleted.

**6.2 Concrete** : Specifications of aggregate from other than natural resources shall comply with requirement of IS 383:2016 have been introduced.

**6.3 Reinforced Cement Concrete** : Specifications of steel reinforcement for R.C.C. work ready to use "Cut and bend rebars, Reinforcement couplers, Precast door & window frames, Expansion joint covering with cement bonded particle board, Expansion joint covering with stainless steel grade 304, RCC for construction of piers, abutment, portal frame, pier caps, bearing pedestals & seismic arresters, RCC diaphragm wall and Expansion joint system for floor, wall & roof joint have been incorporated. Guidelines for multistage centering also introduced in this sub head.

**6.4 Masonry Work** : Specifications of AAC block masonry have been incorporated. The name of sub head Brick work has been renamed as Masonry work.

**6.5 Stone Work** : Specifications of stone work in or under water and /or in liquid mud & under foul position have been incorporated. The specification Clause No. 7.7 Shifted to Sub Head 8 (Cladding work) Under Clause No. 8.8, Clause No. 7.11,7.12 & 7.13 are shifted to Sub Head 8 (Cladding work) under clause No. 8.12, 8.13 & 8.14. Figures 7.14, 7.15 & 7.16 shifted to Sub head 8 (cladding work) under Fig. 8.5, 8.6 & 8.7.

**6.6 Cladding Work** : Specifications of wall lining butch work with Dholpur stone, Kota stone veneering work, Extra for stone work for wall lining, veneered decorative plywood, Air veneer board for general purposes, prelaminated particle board, laminated sandwiched composite panel cladding system and associated works have been incorporated. The name of Sub Head has been renamed as Cladding work from Marble work.

**6.7 Wood Work and PVC Work** : Specifications for cupboard shutter, lipping in pelmet, teak wood lipping, uPVC casement/sliding window & door and Fire resistant glazed doors, windows & partition have been incorporated. Fig. 9.29 to 9.39 have been added. The specification Clause No. 9.9 shifted to Sub Head 8 (cladding work) under clause No. 8.15. Specification of Nickel plated M.S. Pipe curtain rods, M.S. grills in frames of window, Bamboo Jaffery/ fencing, wooden moulded corner beading, magnetic catchers, powder coated telescopic drawer channel, slidling arrangement in racks/ cupboards/ cabinets shutter, hardware fittings for uPVC door/ windows, pre-laminated medium density fibre board and stainless handles have been incorporated.

**6.8 Steel work :** Specifications of dash fasteners, stainless steel railing, Fly proof wire gauze, Glass panes with putty and Glazing clips, Angle iron frames for doors, windows and ventilators have been incorporated.

**6.9 Flooring :** Specifications of pendulum test for skid resistance, Turf paver, Border tiles, Epoxy based grouting for tiles, Italian marble stone flooring and flamed finish granite stone flooring have been incorporated.

**6.10 Finishing :** Specifications of White cement based polymer modified mortar, 1<sup>st</sup> quality distemper for new & old works, Deluxe multi surface paint for interior and exterior, Epoxy Paint, Fire Retardant Paint, G.I. metal tiles ceiling, Heat resistant terrace floor, thermal insulations over existing wall with fiber glass wool, calcium silicate tiles false ceiling, calcium silicate board false ceiling, thermal insulation of ceiling, thermal insulation over existing false ceiling, thermal insulation over existing wall and Melamine Polish have been incorporated.

**6.11 Repairs to building:** Specifications of fixing old wind ties, Brick work in mud mortar, Brass curtain roads, fixing MS round or square bars in wooden frame of window, Wooden karries for roofing, Double Scaffolding system upto seven storey height made with MS tube, Repairs to plaster in patches, Cleaning of water storage tanks, Disconnecting damaged over head/terrace, Replacement of old damaged WC seats, Cutting holes of required size in brick masonry wall, Dismantling of WC pan of all sizes, Hacking of C.C. flooring, Dismantling of 15 mm to 40 mm dia G.I. pipe, Taking out existing wooden door shutter and refixing the same after repairs, Security guard without gun and Security guard with gun have been incorporated. The specification clause no. 14.19, 14.20, 14.21, 14.22, 14.24, 14.25, 14.26, 14.28, 14.29, 14.30 & 14.32 are shifted to Sub Head:- 13 (Finishing) under clause no. 13.14, 13.18, 13.19, 13.21, 13.44, 13.45, 13.46, 13.47, 13.48, 13.35, 13.40 respectively.

**6.12 Road Work:** Specifications of Granular sub base, Wet Mix Macadam (WMM) sub-base/base, Reflective Pavement Markers (RPM) or road studs and Prime coat over granular base have been incorporated. Specification of tack coat with bitumen emulsion has been modified.

**6.13 Sanitary Installations:** Specifications of Hubbles centrifugally cast (spun) iron pipes and fittings, Installation of sink, cutting chase in masonry wall, painting synthetic enamel paint on SCI/ centrifugally cast (spun) iron soil, waste and vent Pipe, Repainting SCI/ Centrifugally cast (spun) iron soil, Waste and vent Pipe, Installation of wall mounted water closet (WC) and Installation of floor mounted single piece water closet (WC) have been incorporated.

**6.14 Water Supply :** Specifications of CP brass bib cock, CP brass long nose bib cock, CP brass long body bib cock, CP brass stop cock, CP brass angle valve, CP brass extension nipple, PTMT bib cock, PTMT stop cock, PTMT pillar cock, PTMT push cock, PTMT grating, PTMT ball cock, PTMT angle stop cock, PVC connection pipe, PTMT extension nipple for water tank pipe, Disinfection C.I. water mains by flushing with water and chrome plated brass battery based infrared sensor operated pillar cock have been introduced.

**6.15 Drainage:** Specifications of dismantling of old S.W. pipes, 6 mm thick plastic encapsulated MS foot rest, Replacement of MS foot rest in manholes, Raising of manhole cover and frame slab, Inspection chamber, Non pressure NP-3 class (medium duty)/NP-4 class (Heavy duty) RCC pipes have been incorporated. Fig 19.19 to Fig. 19.22 have been incorporated.

**6.16 Aluminium Work:** Specifications of Machine moulded aluminium covering over expansion, Anodized aluminium grill, 12mm thick frameless toughened glass door shutter and Non sag elastomeric polyurethane sealant have been incorporated.

**6.17 Water Proofing:** Specifications of Water proofing treatment with Integral crystalline admixture, Fibre reinforced elastomeric liquid water proofing membrane having Sun Reflectivity Index (SRI) of 105, Water proofing treatment with integral crystalline water proofing coating/slurry, Flexible cementitious negative side water proofing coating with elastic water proofing polymers, Water proofing treatment with integral crystalline water proofing dry-shake, Crystalline water proofing mortar and Swellable type water stop tape have been incorporated. The specification clause no. 22.12, 22.13 & 22.14 shifted to sub head 14 (Repairs to Buildings) under clause no. 14.49, 14.50 & 14.51 respectively. Fig. 22.11 & 22.12 shifted to sub head 14 (repairs to buildings) under Fig. 14.10 & 14.11 respectively.



**6.18 Rain Water Harvesting & Tubewells:** New sub head has been introduced and all Specifications kept in this sub head are new specifications.

**6.19 Conservation of heritage building:** New sub head has been introduced and all specifications kept in this sub head are new specifications.

**6.20 Structural glazing aluminium composite panel:** New sub head has been introduced and all specifications kept in this sub head are new specifications.

**6.21 New Technologies and materials:** New sub head has been introduced and all specifications kept in this sub head are new specifications.

**7.0.** A lot of effort has gone into the preparation of CPWD Specifications, 2019. I convey my deep appreciation and sincere thanks to Sh. M. K. Mallick, CE(CSQ), Sh. Divakar Agrawal, SE(TAS), Sh. Satya Narain Jaiswal, EE(TAS-I), Sh. Moti Lal Prasad, EE(TAS-II), Sh. P. Goyal, EE(TAD), Sh. A. K. Sikka, EE(Con.), Sh. M.C. Singhal, EE(QA), Sh. Shivani Kaushal, EE (M), Sh. D.S. Adhikari, AE(QA), Sh. Patta Madhukumar AE (TAS), Sh. Sanjay Singh, AE(TAS), Sh. Jitender Kumar Tiwari, AE(TAS), Sh. Mohammad Tarik AE(QA), Sh. S. K. Sharma, AE(QA), Sh. N. N. Sharma, AE(QA), Sh. K.R. Meena, AE(Con.), Sh. R. K. Sharma, AE(Con.), Sh. S. K. Roy AE(M), Sh. P.K. Upreti, AE(M), Sh. P.K. Verma, AE(TAS), Sh. Gurmeet Singh, AE(TAD), Sh. Ved Khurana, AE(TLC), Sh. Jai Bhagwan, AE(TAS), Sh. Chalapaka Ramaraju, JE(TAD), Sh. Naveen kumar P., JE(TAS), Sh. Mukesh Verma, Chief Estimator (TAS) and other officers and staff of TAS Unit for sincere efforts made in the preparation of this document in such a short time.

**8.0** My sincere thanks to the specifications committee and Sh. Vimal Kumar, CE (NDZ-II), Sh. O.P. Tripathi, CPM IITDPZ & Sh. Sanjay Singh, AE, Sh. Rajeev Singhal, CPM, NDPZ & Sh. Sajal Mitra, EE, Sh. Umesh Bansal, SE, PEC, Sh. V.P. Srivastava, EE, PED, Sh. Manoj Kumar Thakur, AE, PED & Sh. A. K. Grover EE(P), (NDZ)-I, Sh. Anant Kumar, CE (NZ)-V, Sh. Ujjwal Mitra, CE, (NDZ)-III, Sh. Ujjwal Kumar, CE (NDZ)-VI, Sh. Harnam Singh, CPM, (RPZ), Sh. Pradeep Gupta, CE, (ICBRPZ), Sh. Ramesh Chandra, CE, (NDZ)-IV, Sh. Vikas Rana, CE (NDZ)-VII & Sh. Manoj Kumar SE & Sh. Virender Singh, EE, Sh. B. B. Makkar, CPM, SCPZ & Sh. Varun Gupta, AEE & Sh. Savinay Srivastav, AE, Sh. Mohd. Kamal Ahmad, CE, CZ, Bhopal, Sh. L. Dung Dung, CE, (WZ-I), Mumbai, Sh. Manoj Kumar Talreja, CE, ZEZ-II & Surender Kumar Rampal, CE & Sh. Amrender Kumar Jalan EE & Sh. Subhadip Ghosh, AE, Sh. D.Roy Chowdhury, CPM, Sh. K.C.Singh, CE, NZ-I, Sh. N.N.S.Rao, CE, SZ-II & Sh. Mathura Prasad, CE, PWD their teams for great help extended in preparation of this document and graphic cover designing by Sh. Sachin Sharma, Dy. Architect, Ms. Azra Mahwash, Architect & Ms. Roopanshi Goel, Int. Architect.

**9.0** Due care has been taken to print CPWD Specifications, 2019 as correctly as possible. It is, however, possible that some errors might have crept in inadvertently. In case any error or omission is noticed, it may be brought to the notice of the **Superintending Engineer (TAS), CPWD, Room No. 418, A- Wing, Nirman Bhawan, New Delhi.**

Suggestions for improvement are welcome.

(Dr.K.M.Soni)  
ADG (Tech), CPWD,  
Nirman Bhawan, New Delhi

# CONTENTS

## Vol. 2

| <b>SH. No.</b> | <b>Name of Sub-Head</b>                      | <b>Page No.</b> |
|----------------|--|-----------------|
| 13.0           | FINISHING                                    | 625 – 680       |
| 14.0           | REPAIRS TO BUILDINGS                         | 681 – 730       |
| 15.0           | DISMANTLING AND DEMOLISHING                  | 731 – 744       |
| 16.0           | ROAD WORK                                    | 745 – 876       |
| 17.0           | SANITARY INSTALLATIONS                       | 877 – 940       |
| 18.0           | WATER SUPPLY                                 | 941 – 1008      |
| 19.0           | DRAINAGE                                     | 1009 – 1074     |
| 20.0           | PILE WORK                                    | 1075 – 1118     |
| 21.0           | ALUMINIUM WORK                               | 1119 – 1158     |
| 22.0           | WATER PROOFING TREATMENT                     | 1159 – 1206     |
| 23.0           | RAIN WATER HARVESTING & TUBEWELLS            | 1207 – 1240     |
| 24.0           | CONSERVATION OF HERITAGE BUILDINGS           | 1241 – 1256     |
| 25.0           | STRUCTURAL GLAZING ALUMINIUM COMPOSITE PANEL | 1257 – 1274     |
| 26.0           | NEW TECHNOLOGIES AND MATERIALS               | 1275 – 1368     |

For Sub Heads 0.0 to 0.12 see Vol. 1.



**SUB HEAD : 13.0**

**FINISHING**





## CONTENTS

| <i>Clause No.</i> | <i>Brief Description</i>   | <i>Page No.</i> |
|-------------------|--|-----------------|
|                   | List of Bureau of Indian Standards Codes                                   | 631             |
| 13.1              | Cement Plaster 12 mm, 15 mm, or 20 mm                                      | 633             |
| 13.2              | Cement Plaster with a Floating Coat of Neat Cement                         | 636             |
| 13.3              | 18 mm Cement Plaster (Two Coat Work)                                       | 636             |
| 13.4              | 6 mm Cement Plaster on Cement Concrete and Reinforced Cement Concrete Work | 636             |
| 13.5              | 6 mm Cement Plaster for Slab Bearing                                       | 638             |
| 13.6              | Neat Cement Punning  | 638             |
| 13.7              | Rough Cast Plaster   | 639             |
| 13.8              | Pebble Dash Finish (In Situ Work)  | 640             |
| 13.9              | Plain Bands of Cement Mortar   | 640             |
| 13.10             | Moulded Bands of Cement Mortar (Single Coat Work)                          | 641             |
| 13.11             | Moulded Bands of Cement Mortar (Two Coat Work)                             | 641             |
| 13.12             | Cement Water Proofing Compound   | 642             |
| 13.13             | Pointing on Brick Work, Tile Work and Stone Work                           | 642             |
| 13.13A            | White cement based polymer modified mortar                                 | 645             |
| 13.14             | White Washing with Lime  | 646             |
| 13.15             | Satna Lime Washing   | 647             |
| 13.16             | White Washing with Whiting   | 647             |
| 13.17             | Colour Washing   | 648             |
| 13.18             | Dry Distempering   | 648             |
| 13.19             | Oil Emulsion (Oil Bound) Washable Distempering                             | 649             |

|        |  |     |
|--------|--|-----|
| 13.19A | 1st Quality Acrylic Distemper  | 650 |
|        |  |     |
| 13.20  | Cement Primer Coat   | 652 |
|        |  |     |
| 13.21  | Cement Paint   | 652 |
|        |  |     |
| 13.22  | Exterior Painting on Wall  | 653 |
|        |  |     |
| 13.22A | Deluxe multi surface paint for interiors and exteriors                 | 654 |
|        |  |     |
| 13.23  | Painting   | 655 |
|        |  |     |
| 13.24  | Painting Priming Coat on Wood, Iron or Plastered Surfaces              | 659 |
|        |  |     |
| 13.24A | Epoxy Paint  | 661 |
|        |  |     |
| 13.25  | Painting Synthetic Enamel Paint over G.S. Sheets                       | 662 |
|        |  |     |
| 13.26  | Painting Cast Iron Rain Water, Soil, Waste and Vent Pipes and Fittings | 663 |
|        |  |     |
| 13.27  | Painting with Wood Preservative  | 663 |
|        |  |     |
| 13.27A | Fire Retardant Paint   | 664 |
|        |  |     |
| 13.28  | Coal Tarring   | 664 |
|        |  |     |
| 13.29  | Spray Painting with Flat Wall Paint on New Surface                     | 665 |
|        |  |     |
| 13.30  | Spray Painting with Flat Wall Paint on Old Surface                     | 665 |
|        |  |     |
| 13.31  | Wall Painting with Plastic Emulsion Paint                              | 666 |
|        |  |     |
| 13.32  | Painting with Synthetic Enamel Paint                                   | 667 |
|        |  |     |
| 13.33  | Painting with Aluminium Paint  | 668 |
|        |  |     |
| 13.34  | Painting with Acid Proof Paint   | 668 |
|        |  |     |
| 13.35  | Painting with Anti-Corrosive Bitumastic Paint                          | 668 |
|        |  |     |
| 13.36  | Floor Painting   | 669 |
|        |  |     |
| 13.37  | Varnishing   | 669 |

|        |  |     |
|--------|--|-----|
| 13.37A | Melamine Polish  | 671 |
|        |  |     |
| 13.38  | French Spirit Polishing  | 671 |
|        |  |     |
| 13.39  | Bees Waxing or Polishing with Readymade Wax Polish                     | 672 |
|        |  |     |
| 13.40  | Lettering with Paint   | 673 |
|        |  |     |
| 13.41  | Removing Old Paint   | 673 |
|        |  |     |
| 13.42  | Washed Stone Grit Plaster  | 675 |
|        |  |     |
| 13.43  | Gypsum Light Weight Plaster  | 676 |
|        |  |     |
| 13.44  | Painting Cast Iron Rain Water, Soil, Waste and Vent Pipes and fittings | 677 |
|        |  |     |
| 13.45  | Painting with wood preservative  | 677 |
|        |  |     |
| 13.46  | Wall painting with plastic emulsion paint                              | 678 |
|        |  |     |
| 13.47  | Painting with synthetic enamel paint                                   | 679 |
|        |  |     |
| 13.48  | Painting with aluminium paint  | 680 |





### LIST OF BUREAU OF INDIAN STANDARD CODES

| <i>S. No.</i> | <i>BIS. No.</i>   | <i>Subject</i>   |
|---------------|-------------------|--|
| 1.            | IS 16 (Pt-I)      | Shellac : Part : I - Hand Made Shellac   |
|               | IS 16 (Pt-II)     | Shellac : Part : II - Machine Made Shellac   |
| 2.            | IS 75             | Linseed Oil Raw and Refined  |
| 3.            | IS 77             | Linseed Oil Boiled For Paints  |
| 4.            | IS 102            | Ready Mixed Paint, Brushing, Red Lead, Nonsetting, Priming   |
| 5.            | IS 104            | Specification for Ready Mixed Paint, Brushing, Zinc Chrome, Priming  |
| 6.            | IS 109            | Ready Mixed Paint, brushing, priming Plaster to Indian Standard Colour No.361, 631 White and off White   |
| 7.            | IS 117            | Ready Mixed Paint, Brushing, Finishing Exterior, Semigloss for General Purposes to Indian Standards Colours.   |
| 8.            | IS 133            | Enamel, Interior (a) Under Coating (b) Finishing   |
| 9.            | IS 137            | Ready Mixed Paint, Brushing, Matt Or Egg Shell Flat, Finishing Interior to Indian Standard Colour as required  |
| 10.           | IS 158            | Ready Mixed Paint, Brushing, Bituminous Black, Lead Free, Acid, Alkali and Heat Resisting  |
| 11.           | IS 217            | Specification for Cut Back Bitumen   |
| 12.           | IS 218            | Specification for Creosote and Anthracene Oil For Use As Wood Preservatives  |
| 13.           | IS 290            | Coal Tar Black Paint   |
| 14.           | IS 337            | Varnish, Finishing Interior  |
| 15.           | IS 341            | Black Japan, Types 'A', 'B' & 'C'  |
| 16.           | IS 347            | Varnish, Shellac for General Purposes  |
| 17.           | IS 348            | French Polish  |
| 18.           | IS 419            | Putty for Use On Window Frames   |
| 19.           | IS 427            | Distemper, Dry Colour as Required  |
| 20.           | IS 428            | Distemper, Oil Emulsion, Colour as Required  |
| 21.           | IS 524            | Varnish, Finishing, Exterior, Synthetic Air Drying   |
| 22.           | IS 533            | Gum Spirit of Turpentine (Oil of Turpentine)   |
| 23.           | IS 712            | Specification For Building Limes   |
| 24.           | IS 1200 (Pt-XII)  | Method of Measurements of Building and Civil Engineering Works : Part : XII - Plastering and Pointing  |
| 25.           | IS 1200 (Pt-XIII) | Method of Measurements of Building and Civil Engineering Works : Part : XIII - White Washing, Colour Washing Distempering and Painting of Building Surfaces. |

|     |                 |  |
|-----|-----------------|--|
| 26. | IS 1200 (Pt-XV) | Methods of Measurements of Building and Civil Engineering Works : Part : XV - Painting, Polishing, Varnishing etc. |
| 27. | IS 2339         | Aluminium Paint For General Purposes, in Dual Container  |
| 28. | IS 2547 (Pt-II) | Gypsum Building Plasters Pt.II Premixed Light Weight Plasters  |
| 29. | IS 2932         | Enamel, Synthetic, Exterior (a) Undercoating, (b) Finishing  |
| 30. | IS 2933         | Enamel, Exterior (a) Undercoating (b) Finishing  |
| 31. | IS 5410         | Cement Paint   |
| 32. | IS 5411 (Pt-1)  | Plastic Emulsion : Paint Part I For Interior Use   |
| 33. | IS 6278         | Code of Practice For White Washing and Colour Washing  |
| 34. | IS 12777        | Method for classification of flame spread of products  |

## 13.0 FINISHING

### 13.1 CEMENT PLASTER

The cement plaster shall be 12 mm, 15 mm or 20 mm thick as specified in the item.

#### 13.1.1 Scaffolding

For all exposed brick work or tile work double scaffolding independent of the work having two sets of vertical supports shall be provided. The supports shall be sound and strong, tied together with horizontal pieces over which scaffolding planks shall be fixed.

For all other work in buildings, single scaffolding shall be permitted. In such cases the inner end of the horizontal scaffolding pole shall rest in a hole provided only in the header course for the purpose. Only one header for each pole shall be left out. Such holes for scaffolding shall, however, not be allowed in pillars/columns less than one metre in width or immediately near the skew backs of arches. The holes left in masonry works for scaffolding purposes shall be filled and made good before plastering.

**Note :** In case of special type of brick work, scaffolding shall be got approved from Engineer-in-charge in advance.

#### 13.1.2 Preparation of Surface

The joints shall be raked out properly. Dust and loose mortar shall be brushed out. Efflorescence if any shall be removed by brushing and scrapping. The surface shall then be thoroughly washed with water, cleaned and kept wet before plastering is commenced.

In case of concrete surface if a chemical retarder has been applied to the form work, the surface shall be roughened by wire brushing and all the resulting dust and loose particles cleaned off and care shall be taken that none of the retarders is left on the surface.

#### 13.1.3 Mortar

The mortar of the specified mix using the type of sand described in the item shall be used. It shall be as specified in Subhead 3.0. For external work and under coat work, the fine aggregate shall conform to grading IV. For finishing coat work the fine aggregate conforming to grading zone V shall be used.

#### 13.1.4 Application of Plaster

**13.1.4.1** Ceiling plaster shall be completed before commencement of wall plaster.

**13.1.4.2** Plastering shall be started from the top and worked down towards the floor. All putlog holes shall be properly filled in advance of the plastering as the scaffolding is being taken down. To ensure even thickness and a true surface, plaster about 15 × 15 cm shall be first applied, horizontally and vertically, at not more than 2 metres intervals over the entire surface to serve as gauges. The surfaces of these gauged areas shall be truly in the plane of the finished plaster surface. The mortar shall then be laid on the wall, between the gauges with trowel. The mortar shall be applied in a uniform surface slightly more than the specified thickness. This shall be brought to a true surface, by working a wooden straight edge reaching across the gauges, with small upward and side ways movements at a time. Finally the surface shall be finished off true with trowel or wooden float according as a smooth or a sandy granular texture is required. Excessive troweling or over working the float shall be avoided.

**13.1.4.3** All corners, arrises, angles and junctions shall be truly vertical or horizontal as the case may be and shall be carefully finished. Rounding or chamfering corners, arrises, provision of grooves at junctions etc. where required shall be done without any extra payment. Such rounding, chamfering or grooving shall be carried out with proper templates or battens to the sizes required.



**13.1.4.4** When suspending work at the end of the day, the plaster shall be left, cut clean to line both horizontally and vertically. When recommencing the plastering, the edge of the old work shall be scrapped cleaned and wetted with cement slurry before plaster is applied to the adjacent areas, to enable the two to properly join together. Plastering work shall be closed at the end of the day on the body of wall and not nearer than 15 cm to any corners or arrises. It shall not be closed on the body of the features such as plasters, bands and cornices, nor at the corners of arrises. Horizontal joints in plaster work shall not also occur on parapet tops and copings as these invariably lead to leakages. The plastering and finishing shall be completed within half an hour of adding water to the dry mortar.

No portion of the surface shall be left out initially to be patched up later on. The plastering and finishing shall be completed within half an hour of adding water to the dry mortar.

#### **13.1.5 Thickness**

Where the thickness required as per description of the item is 20 mm the average thickness of the plaster shall not be less than 20 mm whether the wall treated is of brick or stone. In the case of brick work, the minimum thickness over any portion of the surface shall be not less than 15 mm while in case of stone work the minimum thickness over the bushings shall be not less than 12 mm.

#### **13.1.6 Curing**

Curing shall be started as soon as the plaster has hardened sufficiently not to be damaged when watered.

The plaster shall be kept wet for a period of at least 7 days. During this period, it shall be suitably protected from all damages at the contractor's expense by such means as the Engineer-in-Charge may approve. The dates on which the plastering is done shall be legibly marked on the various sections plastered so that curing for the specified period thereafter can be watched.

#### **13.1.7 Finish**

The plaster shall be finished to a true and plumb surface and to the proper degree of smoothness as required. The work shall be tested frequently as the work proceeds with a true straight edge not less than 2.5 m long and with plumb bobs. All horizontal lines and surfaces shall be tested with a level and all jambs and corners with a plumb bob as the work proceeds.

#### **13.1.8 Precaution**

Any cracks which appear in the surface and all portions which sound hollow when tapped, or are found to be soft or otherwise defective, shall be cut out in rectangular shape and redone as directed by the Engineer-in-Charge.

- (i) When ceiling plaster is done, it shall be finished to chamfered edge at an angle at its junction with a suitable tool when plaster is being done. Similarly when the wall plaster is being done, it shall be kept separate from the ceiling plaster by a thin straight groove not deeper than 6 mm drawn with any suitable method with the wall while the plaster is green.
- (ii) To prevent surface cracks appearing between junctions of column/beam and walls, 150 mm wide chicken wire mesh should be fixed with U nails 150 mm centre to centre before plastering the junction. The plastering of walls and beam/column in one vertical plane should be carried out in one go. For providing and fixing chicken wire mesh with U nails payment shall be made separately.

#### **13.1.9 Measurements**

**13.1.9.1** Length and breadth shall be measured correct to a cm and its area shall be calculated in square metres correct to two places of decimal.

**13.1.9.2** Thickness of the plaster shall be exclusive of the thickness of the key i.e. grooves, or open joints in brick work.

**13.1.9.3** The measurement of wall plaster shall be taken between the walls or partitions (the dimensions before the plaster shall be taken) for the length and from the top of the floor or skirting to the ceiling for the height. Depth of coves or cornices if any shall be deducted.

**13.1.9.4** The following shall be measured separately from wall plaster.

- (a) Plaster bands 30 cm wide and under
- (b) Cornice beadings and architraves or architraves moulded wholly in plaster.
- (c) Circular work not exceeding 6 m in radius.

**13.1.9.5** Plaster over masonry pilasters will be measured and paid for as plaster only.

**13.1.9.6** A coefficient of 1.63 shall be adopted for the measurement of one side plastering on honey comb work having 6 x 10 cm. opening.

**13.1.9.7** Moulded cornices and coves.

- (a) Length shall be measured at the centre of the girth.
- (b) Moulded cornices and coves shall be given in square metres the area being arrived at by multiplying length by the girth.
- (c) Flat or weathered top to cornices when exceeding 15 cm in width shall not be included in the girth but measured with the general plaster work.
- (d) Cornices which are curved in their length shall be measured separately.

**13.1.9.8** Exterior plastering at a height greater than 10 m from average ground level shall be measured separately in each storey height. Patch plastering (in repairs) shall be measured as plastering new work, where the patch exceed 2.5 sqm. extra payment being made for preparing old wall, such as dismantling old plaster, raking out the joints and cleaning the surface. Where the patch does not exceed 2.5 sqm in area it shall be measured under the appropriate item under sub head 'Repairs to Buildings.'

**13.1.9.9** Deductions in measurements, for opening etc. will be regulated as follows:

- (a) No deduction will be made for openings or ends of joists, beams, posts, girders, steps etc. upto 0.5 sqm in area and no additions shall be made either, for the jambs, soffits and sills of such openings. The above procedure will apply to both faces of wall.
- (b) Deduction for opening exceeding 0.5 sqm but not exceeding 3 sqm each shall be made for reveals, jambs, soffits sills, sills, etc. of these openings.
  - (i) When both faces of walls are plastered with same plaster, deductions shall be made for one face only.
  - (ii) When two faces of walls are plastered with different types of plaster or if one face is plastered and other is pointed or one face is plastered and other is unplastered, deduction shall be made from the plaster or pointing on the side of the frame for the doors, windows etc. on which width of reveals is less than that on the other side but no deduction shall be made on the other side.  
Where width of reveals on both faces of wall are equal, deduction of 50% of area of opening on each face shall be made from area of plaster and/or pointing as the case may be.
  - (iii) For opening having door frame equal to or projecting beyond thickness of wall, full deduction for opening shall be made from each plastered face of wall.
- (c) For opening exceeding 3 sqm in area, deduction will be made in the measurements for the full opening of the wall treatment on both faces, while at the same time, jambs, sills and soffits will be measured for payment.

In measuring jambs, sills and soffits, deduction shall not be made for the area in contact with the frame of doors, windows etc.

### **13.1.10 Rate**

The rate shall include the cost of all labour and materials involved in all the operations described above.

## **13.2 CEMENT PLASTER WITH A FLOATING COAT OF NEAT CEMENT**

**13.2.0** The cement plaster shall be 12, 15 or 20 mm thick, finished with a floating coat of neat cement, as described in the item.

**13.2.1** Specifications for this item of work shall be same as described in 13.1 except for the additional floating coat which shall be carried out as below.

When the plaster has been brought to a true surface with the wooden straight edge (clause 13.1.4.2) it shall be uniformly treated over its entire area with a paste of neat cement and rubbed smooth, so that the whole surface is covered with neat cement coating. The quantity of cement applied for floating coat shall be 1 kg per sqm. Smooth finishing shall be completed with trowel immediately and in no case later than half an hour of adding water to the plaster mix. The rest of the specifications described in 13.1.4 shall apply.

## **13.3 18 MM CEMENT PLASTER (TWO COAT WORK)**

**13.3.1** The specification for scaffolding and preparation of surface shall be as described in 13.1

### **13.3.2 Mortar**

The mix and type of fine aggregate specified in the description of the item shall be used for the respective coats. Generally the mix of the finishing coat shall not be richer than the under coat unless otherwise described in item.

Generally coarse sand shall be used for the under coat and fine sand for the finishing coat, unless otherwise specified for external work and under coat work, the fine aggregate shall conform to grading zone IV. For finishing coat work the fine aggregate conforming to grading zone V shall be used.

### **13.3.3 Application**

**13.3.3.1** The plaster shall be applied in two coats i.e. 12 mm under coat and then 6 mm finishing coat and shall have an average total thickness of not less than 18 mm.

**13.3.3.2 12 mm Under Coat :** This shall be applied as specified in 13.1.4 except that when the plaster has been brought to a true surface a wooden straight edge and the surface shall be left rough and furrowed 2 mm deep with a scratching tool diagonally both ways, to form key for the finishing coat. The surface shall be kept wet till the finishing coat is applied.

**13.3.3.3 6 mm Finishing Coat :** The finishing coat shall be applied after the under coat has sufficiently set but not dried and in any case within 48 hours and finished in the manner specified in 13.1.4.

**13.3.4** Specifications for Curing, Finishing, Precautions, Measurements and Rate shall be as described under 13.1.

## **13.4 6 MM CEMENT PLASTER ON CEMENT CONCRETE AND REINFORCED CEMENT CONCRETE WORK**

### **13.4.1 Scaffolding**

Stage scaffolding shall be provided for the work. This shall be independent of the walls.

#### **13.4.2 Preparation of Surface**

Projecting burrs of mortar formed due to the gaps at joints in shuttering shall be removed. The surface shall be scrubbed clean with wire brushes. In addition concrete surfaces to be plastered shall be pock marked with a pointed tool, at spacings of not more than 5 cm. Centres, the pock being made not less than 3 mm deep. This is to ensure a proper key for the plaster. The mortar shall be washed off and surface, cleaned off all oil, grease etc. and well wetted before the plaster is applied.

#### **13.4.3 Mortars**

Mortar of the specified mix using the types of sand described in the item shall be used. It shall be as specified in 3.2.

#### **13.4.4 Application**

To ensure even thickness and a true surface, gauges of plaster 15 x 15 cm. shall be first applied at not more than 1.5 m intervals in both directions to serve as guides for the plastering. Surface of these gauged areas shall be truly in the plane of the finished plaster surface. The plaster shall be then applied in a uniform surface to a thickness slightly more than the specified thickness and shall then be brought to true and even surface by working a wooden straight edge reaching across the gauges. Finally the surface shall be finished true with a trowel or with wooden float to give a smooth or sandy granular texture as required. Excess troweling or over working of the floats shall be avoided. The plastering and finishing shall be completed within half an hour of adding water to the dry mortar.

Plastering of ceiling shall not be commenced until the slab above has been finished and centring has been removed. In the case of ceiling of roof slabs, plaster shall not be commenced until the terrace work has been completed. These precautions are necessary in order that the ceiling plaster is not disturbed by the vibrations set up in the above operations.

#### **13.4.5 Finish**

The plaster shall be finished to a true and plumb surface and to the proper degree of smoothness as required. The work shall be tested frequently as the work proceeds with a true straight edge not less than 2.5 m long and with plumb bobs. All horizontal lines and surfaces shall be tested with a level and all jambs and corners with a plumb bob as the work proceeds.

#### **13.4.6 Thickness**

The average thickness of plaster shall not be less than 6 mm. The minimum thickness over any portion of the surface shall not be less than 5 mm.

#### **13.4.7 Curing**

The specifications shall be as detailed in 13.1.6.

#### **13.4.8 Precautions**

The specifications shall be as detailed in 13.1.8.

#### **13.4.9 Measurements**

**13.4.9.1** Length and breadth shall be measured correct a cm. and its area shall be calculated in sqm. correct to two places of decimal. Dimensions before plastering shall be taken.

**13.4.9.2** Thickness of plaster shall be exclusive of the thickness of the key i.e. depth or rock marks and hacking.

**13.4.9.3** Plastering on ceiling at height greater than 5 m above the corresponding floor level shall be so described and shall be measured separately stating the height in stages of 1 m or part thereof.

**13.4.9.4** Plastering on the sides and soffits of the projected beams of ceiling at a height greater than 5 m above the corresponding floor level shall be measured and added to the quantity measured under 13.4.9.3.

**13.4.9.5** Plastering on spherical and groined ceiling and circular work not exceeding 6 m in radius, shall be measured and paid for separately.

**13.4.9.6** Flowing soffits (*viz.* portion under spiral stair case etc.) shall be measured and paid for separately.

**13.4.9.7** Ribs and mouldings on ceiling shall be measured as for cornices, deductions being made from the plastering on ceiling in case the width of the moulding exceed 15 cm.

**13.4.9.8** The mode of measurement of exterior plastering and patch plastering (in repairs) shall be as laid down in 13.1.9.8

**13.4.9.9** Deduction shall not be made for openings or for ends of columns, or columns caps of 0.5 sqm each in area and under. No additions will be made either for the plastering of the sides of such openings. For openings etc. of areas exceeding 0.5 sqm deduction will be made for the full opening but the sides of such openings shall be measured for payment.

#### **13.4.10 Rate**

The rate shall include the cost of all labour and materials involved in all the operations described above.

### **13.5 6 MM CEMENT PLASTER FOR SLAB BEARING**

**13.5.0** Cement plaster shall be 6 mm thick finished with a floating coat of neat cement and thick coat of lime wash on top of walls for bearing of slabs.

#### **13.5.1 Application**

The plaster shall be applied over the cleaned and wetted surface of the wall. When the plaster has been brought to a true surface with the wooden straight edge (Clause 13.1.4) it shall be uniformly treated over its entire area with a paste of neat cement and rubbed smooth, so that the whole surface is covered with neat cement coating. The quantity of cement applied for floating coat shall be 1 kg per sqm. Smooth finishing shall be completed with trowel immediately and in no case later than half an hour of adding water to the plaster mix. The rest of the specifications described in 13.1.4 shall apply.

#### **13.5.2 Lime wash**

This shall be applied in a thick coat after curing the plaster for three days.

#### **13.5.3 Measurements**

Length and breadth shall be measured correct to a cm and area worked out in sqm correct to two places of decimal.

#### **13.5.4 Rate**

The rate shall include the cost of all labour and materials involved in all the operations described above.

### **13.6 NEAT CEMENT PUNNING**

**13.6.1** The specifications given for floating coat described in 13.2.1 shall apply.

**13.6.2** Specification for scaffolding and curing shall be as described in 13.1.1 and 13.1.6. respectively. Specifications for Finish and Precautions shall be as described in 13.1.7. and 13.1.8.

### **13.6.3 Measurements**

**13.6.3.1** The measurements for cement punning shall be taken over the finished work. The length and breadth shall be measured correct to a cm. The area shall be calculated in sqm correct to two places of decimal.

**13.6.3.2** Punning over Plaster on bands, skirting, coping, cornices, drip courses, string courses etc. shall not be measured separately but only as wall surfaces. In these cases the measurements shall be taken girthed over the above features.

**13.6.3.3** Punning over plaster on circular work also, of any radius shall be measured only as wall surfaces, and not separately.

**13.6.3.4** Cement punning in patch repairs irrespective of the size of the patch shall be measured as new work, and in this case the rate shall include for cutting the patch to rectangular shape before lime punning.

**13.6.3.5** Deductions in measurements for openings shall be regulated generally as described in 13.1.9.9.

### **13.6.4 Rate**

The rate shall include the cost of all labour and materials involved in all the operations described above.

## **13.7 ROUGH CAST PLASTER**

**13.7.0** Rough cast finish comprises of a mixture of sand and gravel in specified proportions dashed over a freshly plastered surface.

### **13.7.1 Scaffolding**

Scaffolding shall be done as specified in 13.1.1.

### **13.7.2 Preparation of Surface**

The joints shall be raked out, dust and loose mortar, shall be brushed out. The surface shall be thoroughly washed with water, cleaned and kept wet before plastering is commenced.

### **13.7.3 Mortar**

Mortar of specified mix using the type of sand described in the item shall be used, where coarse sand is to be used, the fineness modulus of the sand shall not be less than 2.5 mm.

### **13.7.4 Application**

**13.7.4.1** The plaster base over which rough cast finish is to be applied shall consist of two coats, under layer 12 mm thick and top layer 10 mm.

**13.7.4.2 12 mm Under Layer :** This shall be applied in the same manner as specified in para 13.1.3 under 18 mm cement plaster except that the finishing, after the mortar has been brought to a level with the wooden straight edge, shall be done with wooden float only.

**13.7.4.3 Top Layer :** The top layer shall be applied a day or two after the under layer has taken initial set. The latter shall not be allowed to dry out, before the top layer is laid on. The mortar used for applying top layer shall be sufficiently plastic and of rich mix 1 : 3 (1 cement : 3 fine sand) or as otherwise specified so that the mix of sand and gravel gets well pitched with the plaster surface. In order to make the base plastic, about 10% of finely grouted hydrated lime by volume of cement, shall be added when preparing mortar for the top layer.

### **13.7.5 Finish**

It shall be ensured that the base surface which is to receive rough cast mixture is in plastic state. The rough cast mixture shall consist of sand or gravel or crushed stone of uniform colour from 2.36 mm to 12.5 mm or as specified and in the proportions as specified accurately to the effect required. The mixture shall be wetted and shall be dashed on the plaster base in plastic state by hand scoop so that the mix get well pitched into the plaster base. The mix shall again be dashed over the vacant spaces if any so that the surface represents a homogeneous surfaces of sand mixed with gravel. A sample of rough cast plaster shall be got approved by the Engineer-in-Charge.

**13.7.6** Specification for other details like precautions, measurement and rate shall be as described under 13.1.

### **13.8 PEBBLE DASH FINISH (IN SITU WORK)**

**13.8.1** The specification shall be the same as for rough cast plaster, except that the washed pebble or crushed stone graded from 12.5 mm to 6.3 mm or as specified shall be dashed over the plaster base and the vacant spaces if any shall be filled in by pressing pebbles or crushed stone as specified by hand, so that the finished surface represents a homogeneous surface.

**13.8.2** Specification for scaffolding, preparation of surface, Mortar, Measurements and Rate shall be as described under 13.7.

### **13.9 PLAIN BANDS OF CEMENT MORTAR**

**13.9.0** 'Plain band' is a plaster strip of uniform width not exceeding 30 cm and of uniform thickness, provided for decorative or other purpose flush with, sunk below or projecting beyond, the wall plaster. A flush band is one where due to the difference in mix or shade of the mortar, the band is executed as a separate and distinct operation from the wall plaster.

#### **13.9.1 Thickness**

The thickness of a raised band is the thickness of the projection beyond the plane of the wall plaster.

In the case of a flush or a sunk band, the thickness will be the thickness of the plaster measured from the untreated wall surface.

#### **13.9.2 Preparation of Surfaces and Application**

**13.9.2.1** In the case of flush or sunk bands the joints shall be raked out properly. Dust and loose mortar shall be brushed out. Efflorescence if any shall be removed by brushing the scraping. The surface shall then be thoroughly washed with water, cleaned and kept wet before plastering is commenced.

In case of concrete surface if a chemical retarder has been applied to the form work, the surface shall be roughened by wire brushing and all the resulting dust and loose particles cleaned off and care shall be taken that none of the retarders is left on the surface.

**13.9.2.2** In case of raised band, the surface shall be prepared as specified in 13.1.4. The surface of the wall plaster behind the band shall be left rough and furrowed 2 mm deep with a scratching tool, diagonally both ways to form key for the band. No reduction in the rate for the above backing wall plaster shall, however, be made for not finishing the same smooth.

#### **13.9.3 Mortar**

Mortar of the mix and type of sand specified in the description of the item shall be used.



#### **13.9.4 Finish**

The bands shall be finished exactly to the size as shown in the drawings. The horizontal or vertical lines of bands shall be truly parallel and straight and the surfaces shall be finished truly plane and smooth. The lines and surfaces shall be checked with fine threads for straightness, level and accuracy.

**13.9.5** Scaffolding, Curing and Precaution shall be as described under 13.1.

#### **13.9.6 Measurements**

Length will be measured in running metres correct to a cm. The length shall be taken along the finished face. The width shall not be measured by girth. For width of band 30 cm or below, the width shall be measured in cm correct to 5 mm. The quantity shall be calculated in metre-cm units.

#### **13.9.7 Rate**

The rate shall include the cost of all labour and materials involved in all the operations described above. Nothing extra shall be paid for mitres, stops nor for bands on curved surfaces of whatever radius, they may be. The rate is also inclusive of all rounding or chamfering at corners, arrisers, providing grooves at junctions etc.

### **13.10 MOULDED BANDS OF CEMENT MORTAR (SINGLE COAT WORK)**

**13.10.0** Moulded band is a plaster strip of uniform width but with varying thickness across its section formed over wall plaster for decorative purposes. The sectional periphery of the band is formed by a combination of straight lines or of curves or of straight lines and curves.

#### **13.10.1 Thickness**

The higher thickness stipulated in the description of the item shall refer to the upper limiting thickness of the moulding at its most projected portion, measured from the wall plaster.

**13.10.2** Preparation of Surface, Mortar, Scaffolding, Curing and Precautions shall be as specified under 13.9.

#### **13.10.3 Application and Finish**

Proper templates conforming accurately to the sectional periphery of the moulded band shall be got approved, before use. The finished band shall be true to the template at all sections. The lines of the band shall be truly parallel and straight and surfaces smoothly finished.

#### **13.10.4 Measurements**

The width of the band 30 cm or below shall be measured in cm correct to 5 mm and shall be measured along the sectional periphery of the moulded band, from wall plaster face to wall plaster face. The length shall be measured, in running metres correct to a cm. It shall be taken along the finished face of the band at the centre of its girth. The quantity should be calculated in metre-cm units.

#### **13.10.5 Rate**

The rate shall include the cost of all labour and materials involved in all the operations described above. Nothing extra shall be paid for mitres, stops nor for bands on curved surfaces of whatever radius, they may be. The rate is also inclusive of all rounding or chamfering at corners, arrisers etc.

### **13.11 MOULDED BANDS OF CEMENT MORTAR (TWO COAT WORK)**

**13.11.0** Moulded band is a plaster strip of uniform width but with varying thickness across its section formed over wall plaster for decorative purposes. The sectional periphery of the band is formed by a combination of straight lines or of curves or of straight lines and curves.

#### **13.11.1 Thickness**

The higher thickness stipulated for the under coat in the description of the item shall refer to the upper limiting thickness of the under coat of the moulding at its most projected portion from the wall plaster.

The thickness stipulated for the finishing coat is the uniform thickness of the finished peripheral surface of the moulded band from the under coat.



**13.11.2 Mortar**

The under coat shall consist of cement mortar 1 : 5 (1 cement : 5 coarse sand) and the top coat shall be of cement mortar 1 : 4 (1 cement : 4 fine sand) unless otherwise specified in the description of item.

**13.11.3 Application and Finish**

Proper templates conforming to the sectional periphery of the moulded band as at the stages of the under coat and the finished final coat shall be made and got approved and used at the proper stages in executing the bands to true and accurate profile. The lines of the bands as finally completed shall be truly parallel and straight and the surfaces smoothly finished.

13.11.4 All other details shall be as specified under 13.10.

**13.12 CEMENT WATER PROOFING COMPOUND**

13.12.0 It shall be used for cement mortar for plastering or concrete work.

**13.12.1 Water Proofing Compound**

Integral cement water proofing compound conforming to IS 2645 and of approved brand and manufacture, enlisted by the Engineer-in-Charge from time to time shall be used.

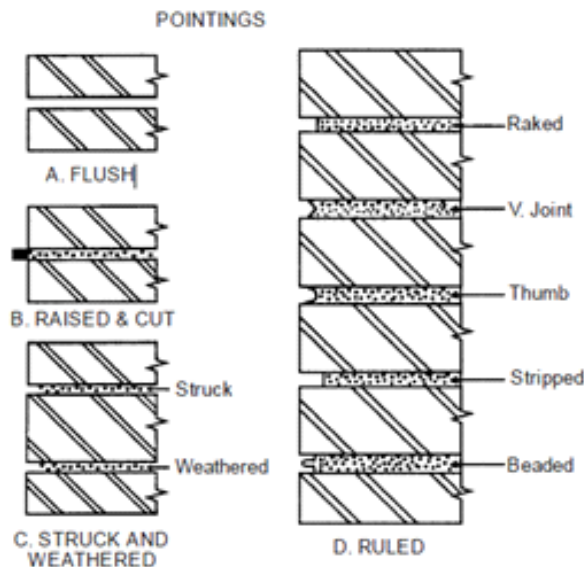
13.12.2 The contractor shall bring the materials to the site in their original packing. The containers will be opened and the material mixed with dry cement in the proportion by weight, recommended by the manufacturers or as specifically described in the description of the item. Care shall be taken in mixing, to see that the water proofing material gets well and integrally mixed with the cement and does not run out separately when water is added.

13.12.3 It shall be measured by weight.

13.12.4 The rate shall include the cost of all labour and materials involved in all the operations described above.

**13.13 POINTING ON BRICK WORK, TILE WORK AND STONE WORK**

13.13.0 Pointing shall be of the type shown in figure below:



Drawings not to Scale

### **13.13.1 Scaffolding**

For all exposed brick work, tile work or stone work independent double scaffolding having two sets of vertical supports shall be provided. The supports shall be sound and strong tied together with horizontal pieces over which scaffolding planks shall be fixed.

For all other work in building, single scaffolding shall be permitted. In such cases, the inner end of the horizontal scaffolding pole shall rest in a hole provided only in the header course for the purpose. Only one header for each pole shall be left out. Such holes for scaffolding shall, however, not be allowed in pillars/columns less than one metre in width, or immediately near the skew backs of arches. The holes left in masonry works for scaffolding purposes shall be filled and made good before plastering.

**Note :** In case of special type of work, scaffolding shall be got approved from Engineer-in-Charge in advance.

### **13.13.2 Preparation of surface**

The joints shall be raked out properly. Dust and loose mortar shall be brushed out. Efflorescence if any shall be removed by brushing and scraping. The surface shall then be thoroughly washed with water, cleaned and kept wet before pointing is commenced.

In case of concrete surface if a chemical retarder has been applied to the form work, the surface shall be roughened by wire brushing and all the resulting dust and loose particles cleaned off and care shall be taken that none of the retarders is left on the surface.

The joints shall be raked to such a depth that the minimum depth of the new mortar measured from either the sunk surface of the finished pointing or from the edge of the brick shall not be less than 12 mm.

### **13.13.3 Mortar**

Mortar of specified mix shall be used. It shall be as specified under Chapter 3.0.

### **13.13.4 Application and Finishing**

**13.13.4.1** The mortar shall be pressed into the raked out joints, with a pointing trowel, either flush, sunk or raised, according to the type of pointing required. The mortar shall not spread over the corner, edges or surface of the masonry. The pointing shall then be finished with the proper tool, in the manner described below:

**13.13.4.2 Flush Pointing :** The mortar shall be pressed into the joints and shall be finished off flush and level with the edges of the bricks, tiles or stones so as to give a smooth appearance. The edges shall be neatly trimmed with a trowel and straight edge.

**13.13.4.3 Ruled Pointing :** The joints shall be initially formed as for flush pointing and then while the mortar is still green, a groove of shape and size as shown in drawings or as instructed, shall be formed by running a forming tool, straight along the centre line of the joints. This operation shall be continued till a smooth and hard surface is obtained. The vertical joints shall also be finished in a similar way. The vertical lines shall make true right angles at their junctions with the horizontal lines and shall not project beyond the same.

**13. 13.4.4 Cut or Weather Struck Pointing:** The mortar shall first be pressed into the joints. The top of the horizontal joints shall then be neatly pressed back about 3 mm or as directed, with the pointing tool so that the joints are sloping from top to bottom.

The vertical joints shall be ruled pointed. The junctions of vertical joints with the horizontal joints shall be at true right angles.

**13.13.4.5 Raised and Cut Pointing :** Raised and cut pointing shall project from the wall facing with its edges cut parallel so as to have a uniformly raised band about 6 mm raised and width 10 mm more as directed.

**13.13.4.6** The superfluous mortar shall then be cut off from the edges of the lines and the surface of the masonry shall also be cleaned off all mortar. The finish shall be such that the pointing is to the exact size and shape required and the edges are straight, neat and clean.

**13.13.5 Curing**

The pointing shall be kept wet for seven days. During this period it shall be suitably protected from all damages.

The pointing lines shall be truly horizontal and vertical except where the joints are slanting as in rubble random masonry. Lines of joints from different directions should meet neatly at the junctions instead of crossing beyond.

**13.13.6 Measurements**

**13.13.6.1** Length and breadth shall be measured correct to a cm and its area shall be calculated in square metres upto two places of decimal.

**13.13.6.2** The various types of pointing for example, struck, keyed, flush, tuck, etc. shall each be measured separately.

**13.13.6.3** Pointing on different types of walls, floors, roofs etc. shall each be measured separately. The type and material of the surface to be pointed shall be described.

**13.13.6.4** Pointing in a single detached joint as for flashing shall be given in running metres.

**13.13.6.5** For jambs, soffits, sills etc. for opening not exceeding 0.5 sqm each in area, ends of joists, beams, posts, girders, steps etc. not exceeding 0.5 sqm each in area and opening not exceeding 3 sqm each deductions and additions shall be made in the following way, in case of pointing on external face only.

- (a) No deduction shall be made for ends of joists, beams, posts etc. and openings not exceeding 0.5 sqm each, and no addition shall be made for reveals, jambs, soffits, sills, etc. of these openings.
- (b) Deductions for openings exceeding 0.5 sqm but not exceeding 3 sqm each shall be made as follows and no additions shall be made for reveals, jambs, soffits, sills, etc. for these openings.
- (c) When both the faces of the wall are pointed with the same pointing deduction shall be made for one face only.
- (d) When two faces of wall are pointed with different pointings or if one face is plastered and other is pointed or plastered, deduction shall be made from the plaster or pointing on the side of frames for doors, windows, etc. on which the width of the reveal is less than that on the other side, but no deduction shall be made from the other side.
- (e) Where width of reveals on both faces of wall are equal, deduction of 50% of area of opening on each face shall be made from area of pointing or plaster as the case may be.
- (f) For opening having door frame equal to or projecting beyond thickness of wall, full deduction for opening shall be made from each pointed face of wall.

**13.13.6.6** In case of openings of area above 3 sqm each, deduction shall be made for the openings, but jambs, soffits and sills shall be measured.

**13.13.6.7** The following shall be measured separately.

- (a) Raking out joints for old work only shall be measured and given in square metres.
- (b) Raking out joints of old work built in mud mortar, lime mortar and cement mortar shall each be measured separately.
- (c) Raking out joints of different types of old walls, floors etc. shall each be measured separately.
- (d) Raking single detached joints as for flashing old work shall be given in running metres.

### **13.13.7 Rate**

The rate shall include the cost of all materials and labour involved in all the operations described above.

## **13.13A WHITE CEMENT BASED POLYMER MODIFIED MORTAR**

### **13.13A.1 Materials**

Polymer modified mortar is a two component polymer modified repair mortar composed of powder component based on cement binder, properly graded aggregates and additives & second component is liquid polymer of approved make it is to be mixed with water on site to produce a highly consistent, high strength cement mortar. It is specially designed for repairs of RCC members like beams & columns, slabs & walls because it provides high compressive strength, high resistance to chlorides and carbon dioxide.

### **13.13A.2 Scaffolding**

Scaffolding as required for the proper execution of the work shall be erected. If work can be done safely with the ladder or jhoola these will be permitted in place of scaffolding.

### **13.13A.3 Areas of Application**

Repair & Reinstatement of Spalled concrete in RCC members beams, columns etc.

### **13.13A.4 Method of Application**

#### **13.13A.4.1 Surface Preparation**

- Expose fully any corroded steel in the repair area and remove all scale and corrosion deposits mechanically or ideally by grit blasting.
- Clean the surface and remove loose concrete, any dust, oil paint, grease etc.

#### **13.13A.4.2 Priming**

- Apply zinc primer of approved make over the cleaned re-bars & allow to dry before repair.
- The substrate should be primed by applying one neat/clear of bonding agent of approved make.

#### **13.13A.4.3 Mixing**

- For normal application use of potable water as per manufacturer's specifications
- First add polymer into water and mix for 2 minutes.
- Then add powder slowly and mix till homogeneous mix is obtained. Mixing must be done with a mixer.

#### **13.13A.4.4 Application**

- Apply the mix to the prepared substrate by hand when primer becomes tacky. Ensure that the material has reached evenly behind bars.
- Mix can be applied in required thickness as per item in a single application.
- Mild cure the prepared surface with water for 3 days.

### **13.13A.5 Measurements**

Length and breadth shall be measured correct to a cm. The area shall be calculated in square metre correct to two places of decimal.

Pre- measurements of the patches to be plastered shall be recorded after the old plaster has been cut and surface prepared.

### **13.13A.6 Rate**

The rate includes the cost of all the materials and labour involved in all the operations described above.

## **13.14 WHITE WASHING WITH LIME**

### **13.14.1 Scaffolding**

**13.14.1.1** Wherever scaffolding is necessary, it shall be erected on double supports tied together by horizontal pieces, over which scaffolding planks shall be fixed. No ballies, bamboos or planks shall rest on or touch the surface which is being white washed.

**13.14.1.2** For all exposed brick work or tile work, double scaffolding having two sets of vertical supports shall be provided. The supports shall be sound and strong, tied together with horizontal pieces over which scaffolding planks shall be fixed.

**Note:** In case of special type of brick work, scaffolding shall be got approved from Engineer-in-Charge in advance.

**13.14.1.3** Where ladders are used, pieces of old gunny bags shall be tied on their tops to avoid damage or scratches to walls.

**13.14.1.4** For white washing the ceiling, proper stage scaffolding shall be erected.

### **13.14.2 Preparation of Surface**

Before new work is white washed, the surface shall be thoroughly brushed free from mortar droppings and foreign matter.

In case of old work, all loose particles and scales shall be scrapped off and holes in plaster as well as patches of less than 50 cm area shall be filled up with mortar of the same mix. Where so specifically ordered by the Engineer -in- Charge, the entire surface of old white wash shall be thoroughly removed by scrapping and this shall be paid for separately. Where efflorescence is observed the deposits may be brushed clean and washed. The surface shall then be allowed to dry for at least 48 hours before white washing is done.

### **13.14.3 Preparation of Lime Wash**

**13.14.3.1** The lime wash shall be prepared from fresh stone white lime (Narnaul or Dehradun quality). The lime shall be thoroughly slaked on the spot, mixed and stirred with sufficient water to make a thin cream. This shall be allowed to stand for a period of 24 hours and then shall be screened through a clean coarse cloth. 40 gm of gum dissolved in hot water, shall be added to each 10 cubic decimetre of the cream. The approximate quantity of water to be added in making the cream will be 5 litres of water to one kg of lime.

**13.14.3.2** Indigo (Neel) upto 3 gm per kg of lime dissolved in water, shall then be added and stirred well. Water shall then be added at the rate of about 5 litres per kg. of lime to produce a milky solution.

### **13.14.4 Application**

**13.14.4.1** The white wash shall be applied with moonj brushes to the specified number of coats. The operation for each coat shall consist of a stroke of the brush given from the top downwards, another from the bottom upwards over the first stroke, and similarly one stroke horizontally from the right and another from the left before it dries.

**13.14.4.2** Each coat shall be allowed to dry before the next one is applied. Further each coat shall be inspected and approved by the Engineer-in-Charge before the subsequent coat is applied. No portion of the surface shall be left out initially to be patched up later on.

**13.14.4.3** For new work, three or more coats shall be applied till the surface presents a smooth and uniform finish through which the plaster does not show. The finished dry surface shall not show any signs of cracking and peeling nor shall it come off readily on the hand when rubbed.

**13.14.4.4** For old work, after the surface has been prepared as described in para 13.14.2 a coat of white wash shall be applied over the patches and repairs. Then a single coat or two or more coats of white wash as stipulated in the description of the item shall be applied over the entire surface. The white washed surface should present a uniform finish through which the plaster patches do not appear. The washing on ceiling should be done prior to that on walls.

**Note :** In case of Hessian ceiling, on no account, lime shall be used as it rots cloth and hessian.

#### **13.14.5 Protective Measures**

Doors, windows, floors, articles of furniture etc. and such other parts of the building not to be white washed, shall be protected from being splashed upon. Splashings and droppings, if any shall be removed by the contractor at his own cost and the surfaces cleaned. Damages if any to furniture or fittings and fixtures shall be recoverable from the contractor.

#### **13.14.6 Measurements**

**13.14.6.1** Length and breadth shall be measured correct to a cm. and area shall be calculated in sqm correct to two places of decimals.

**13.14.6.2** Measurements for Jambs, Soffits and Fills etc. for openings shall be as described in 13.1.9.

**13.14.6.3** Corrugated surfaces shall be measured flat as fixed and the area so measured shall be increased by the following percentages to allow for the girthed area.

|   |     |
|---|-----|
| Corrugated non-asbestos cement sheet      | 20% |
| Semi corrugated non-asbestos cement sheet | 10% |

**13.14.6.4** Cornices and other such wall or ceiling features, shall be measured along the girth and included in the measurements.

**13.14.6.5** The number of coats of each treatment shall be stated. The item shall include removing nails, making good holes, cracks, patches etc. not exceeding 50 sq. cm. each with material similar in composition to the surface to be prepared.

**13.14.6.6** Work on old treated surfaces shall be measured separately and so described.

#### **13.14.7 Rate**

The rate shall include all material and labour involved in all the operations described above.

#### **13.15 SATNA LIME WASHING**

**13.15.0** Satna lime wash shall be used as a base coat where so specified. The specifications for 'white washing with lime' shall apply except that Satna or Katni quality lime shall be used in place of Narnaul or Dehradun quality lime and the wash will be mixed to a thicker consistency. The other details and specifications described in 13.14 will apply in toto.

#### **13.16 WHITE WASHING WITH WHITING**

##### **13.16.1 Preparation of Mix**

Whiting (ground white chalk) shall be dissolved in sufficient quantity of warm water and thoroughly stirred to form a thin slurry which shall then be screened through a clean coarse cloth. Two kg of gum and 0.4 kg of copper sulphate dissolved separately in hot water shall be added for every cum of the slurry which shall then be diluted with water to the consistency of milk so as to make a wash ready for use.

**13.16.2** Other specifications described in 13.14 shall apply in this case also.

### **13.17 COLOUR WASHING**

**13.17.1** The mineral colours, not affected by lime, shall be added to white wash. Indigo (Neel) shall however, not be added. No colour wash shall be done until a sample of the colour wash of the required tint or shade has been got approved from the Engineer-in-Charge. The colour shall be of even tint or shade over the whole surface. If it is blotchy or otherwise badly applied, it shall be redone by the contractor.

For new work, the priming coat shall be of white wash with lime or with whiting as specified in the description of the item. Two or more coats, shall then be applied on the entire surface till it represents a smooth and uniform finish.

For old work, after the surface has been prepared as described in 13.14.2 a coat of colour wash shall be applied over the patches and repairs. Then a single coat, or two or more coats of colour wash, as stipulated in the description of the item shall be applied over the entire surface. The colour washed surface shall present a uniform finish.

The finished dry surface shall not be powdery and shall not readily come off on the hand when rubbed.

**13.17.2** Other specifications as described under 13.14.

### **13.18 DRY DISTEMPERING**

#### **13.18.1 Materials**

Dry distemper of required colour (IS 427) and of approved brand and manufacture shall be used. The shade shall be got approved from the Engineer-in-Charge before application of the distemper. The dry distemper colour as required shall be stirred slowly in clean water using 6 decilitres (0.6 litre) of water per kg of distemper or as specified by the makers. Warm water shall preferably be used. It shall be allowed to stand for at least 30 minutes (or if practicable over night) before use. The mixture shall be well stirred before and during use to maintain an even consistency.

Distemper shall not be mixed in larger quantity than is actually required for one day's work.

#### **13.18.2 Preparation of Surface**

**13.18.2.1** Before new work is distempered, the surface shall be thoroughly brushed free from mortar droppings and other foreign matter and sand papered smooth.

**13.18.2.2** New plastered surfaces shall be allowed to dry completely, before applying, distemper.

**13.18.2.3** In the case of old work, all loose pieces and scales shall be removed by sand papering. The surface shall be cleaned of all grease, dirt, etc.

**13.18.2.4** Pitting in plaster shall be made good with plaster of paris mixed with the colour to be used. The surface shall then be rubbed down again with a fine grade sand paper and made smooth. A coat of the distemper shall be applied over the patches. The patched surface shall be allowed to dry thoroughly before the regular coat of distemper is applied.

#### **13.18.3 Priming Coat**

A priming coat of whiting (see 13.16) shall be applied over the prepared surface in case of new work, if so stipulated in the description of the item. No white washing coat shall be used as a priming coat for distemper.

The treated surface be allowed to dry before distemper coat is given.



### **13.18.4 Application**

**13.18.4.1** In the case of new work, the treatment shall consist of a priming coat of whitening (As per 13.16) followed by the application of two or more coats of distemper till the surface shows an even colour.

**13.18.4.2** For old work, the surface prepared as described in para 13.14 shall be applied one or more coats of distemper till the surface attains an even colour.

**13.18.4.3** The application of each coat shall be as follows:

The entire surface shall be coated with the mixture uniformly, with proper distemper brushes (ordinary white wash brushed shall not be allowed) in horizontal strokes followed immediately by vertical ones which together shall constitute one coat.

**13.18.4.4** The subsequent coats shall be applied only after the previous coat has dried.

**13.18.4.5** The finished surface shall be even and uniform and shall show no brush marks.

**13.18.4.6** Enough distemper shall be mixed to finish one room at a time. The application of a coat in each room shall be finished in one operation and no work shall be started in any room, which cannot be completed the same day.

**13.18.4.7** After each day's work, the brushes shall be washed in hot water and hung down to dry. Old brushes which are dirty or caked with distemper shall not be used.

**13.18.5** The specifications in respect of scaffolding, protective measures, measurements and rate shall be as described under 13.14.

### **13.19 OIL EMULSION (OIL BOUND) WASHABLE DISTEMPERING**

#### **13.19.1 Materials**

Oil emulsion (Oil Bound) washable distemper (IS 428) of approved brand and manufacture shall be used. The primer where used as on new work shall be cement primer or distemper primer as described in the item. These shall be of the same manufacture as distemper. The distemper shall be diluted with water or any other prescribed thinner in a manner recommended by the manufacturer. Only sufficient quantity of distemper required for day's work shall be prepared.

The distemper and primer shall be brought by the contractor in sealed tins in sufficient quantities at a time to suffice for a fortnight's work, and the same shall be kept in the joint custody of the contractor and the Engineer-in-Charge. The empty tins shall not be removed from the site of work, till this item of work has been completed and passed by the Engineer-in-Charge.

#### **13.19.2 Preparation of the Surface**

**13.19.2.1** For new work the surface shall be thoroughly cleaned of dust, old white or colour wash by washing and scrubbing. The surface shall then be allowed to dry for at least 48 hours. It shall then be sand papered to give a smooth and even surface. Any unevenness shall be made good by applying putty, made of plaster of paris mixed with water on the entire surface including filling up the undulations and then sand papering the same after it is dry.

**13.19.2.2** In the case of old work, all loose pieces and scales shall be removed by sand papering. The surface shall be cleaned of all grease, dirt etc.

Pitting in plaster shall be made good with plaster of paris mixed with the colour to be used. The surface shall then be rubbed down again with a fine grade sand paper and made smooth. A coat of the distemper shall be applied over the patches. The patched surface shall be allowed to dry thoroughly before the regular coat of distemper is applied.



### **13.19.3 Application**

**13.19.3.1 Priming Coat :** The priming coat shall be with distemper primer or cement primer, as required in the description of the item. The application of the distemper primer shall be as described in 13.18.4.

**Note :** If the wall surface plaster has not dried completely, cement primer shall be applied before distempering the walls. But if distempering is done after the wall surface is dried completely, distemper primer shall be applied.

Oil bound distemper is not recommended to be applied, within six months of the completion of wall plaster. However, newly plastered surfaces if required to be distempered before a period of six months shall be given a coat of alkali resistant priming Paint conforming to IS 109 and allowed to dry for atleast 48 hours before distempering is commenced.

For old work no primer coat is necessary.

**13.19.3.2 Distemper Coat :** For new work, after the primer coat has dried for at least 48 hours, the surface shall be lightly sand papered to make it smooth for receiving the distemper, taking care not to rub out the priming coat. All loose particles shall be dusted off after rubbing. One coat of distemper properly diluted with thinner (water or other liquid as stipulated by the manufacturer) shall be applied with brushes in horizontal strokes followed immediately by vertical ones which together constitutes one coat.

The subsequent coats shall be applied in the same way. Two or more coats of distemper as are found necessary shall be applied over the primer coat to obtain an even shade.

A time interval of at least 24 hours shall be allowed between successive coats to permit proper drying of the preceding coat.

For old work the distemper shall be applied over the prepared surface in the same manner as in new work. One or more coats of distemper as are found necessary shall be applied to obtain an even and uniform shade.

15 cm double bristled distemper brushes shall be used. After each days work, brushes shall be tho-roughly washed in hot water with soap solution and hung down to dry. Old brushes which are dirty and caked with distemper shall not be used on the work.

**13.19.4** The specifications in respect of scaffolding, protective measures and measurements shall be as described under 13.14.

### **13.19.5 Rate**

The rate shall include the cost of all labour and materials involved in all the above operations (including priming coat) described above.

### **13.19A 1<sup>st</sup> QUALITY ACRYLIC DISTEMPER**

#### **13.19A.1 Materials**

1<sup>st</sup> quality acrylic distemper having VOC content less than 50 gms/litre of approved brand and manufacture shall be used. The acrylic distemper shall be diluted with water or any other prescribed thinner in a manner recommended by the manufacturer. Only sufficient quantity of distemper required for day's work shall be prepared.

The distemper shall be brought by the contractor in sealed tins in sufficient quantities at a time to suffice for a fortnight's work, and the same shall be kept in the joint custody of the contractor and the Engineer-in-Charge. The empty tins shall not be removed from the site of work, till this item of work has been completed and passed by the Engineer-in-Charge.

### **13.19A.2 Preparation of the Surface**

**13.19A.2.1** For new work the surface shall be thoroughly cleaned of dust, old white or colour wash by washing and scrubbing. The surface shall then be allowed to dry for at least 48 hours. It shall then be sand papered to give a smooth and even surface. Any unevenness shall be made good by applying putty, made of plaster of paris mixed with water on the entire surface including filling up the undulations and then sand papering the same after it is dry.

**13.19A.2.2** In the case of old work, all loose pieces and scales shall be removed by sand papering. The surface shall be cleaned of all grease, dirt etc.

Pitting in plaster shall be made good with plaster of paris mixed with the colour to be used. The surface shall then be rubbed down again with a fine grade sand paper and made smooth. A coat of the distemper shall be applied over the patches. The patched surface shall be allowed to dry thoroughly before the regular coat of distemper is applied.

### **13.19A.3 Application**

**13.19A.3.1 Priming Coat :** The priming coat shall be with distemper primer or cement primer, as required in the description of the item. The application of the distemper primer shall be as described in 13.18.4.

**Note :** If the wall surface plaster has not dried completely, cement primer shall be applied before distemping the walls. But if distemping is done after the wall surface is dried completely, distemper primer shall be applied.

For old work no primer coat is necessary.

**13.19A.3.2 Distemper Coat :** For new work, after the primer coat has dried for at least 48 hours, the surface shall be lightly sand papered to make it smooth for receiving the distemper, taking care not to rub out the priming coat. All loose particles shall be dusted off after rubbing. One coat of distemper properly diluted with thinner (water or other liquid as stipulated by the manufacturer) shall be applied with brushes in horizontal strokes followed immediately by vertical ones which together constitutes one coat.

The subsequent coats shall be applied in the same way. Two or more coats of distemper as are found necessary shall be applied over the primer coat to obtain an even shade.

A time interval of at least 24 hours shall be allowed between successive coats to permit proper drying of the preceding coat.

For old work the distemper shall be applied over the prepared surface in the same manner as in new work. One or more coats of distemper as are found necessary shall be applied to obtain an even and uniform shade.

15 cm double bristled distemper brushes shall be used. After each days work, brushes shall be tho-roughly washed in hot water with soap solution and hung down to dry. Old brushes which are dirty and caked with distemper shall not be used on the work.

**13.19A.4** The specifications in respect of scaffolding, protective measures and measurements shall be as described under 13.14.

**13.19A.5 Rate**

The rate shall include the cost of all labour and materials involved in all the above operations (including priming coat) described above.

**13.20 CEMENT PRIMER COAT**

**13.20.0** Cement primer coat is used as a base coat on wall finish of cement, lime or lime cement plaster or on non-asbestos cement surfaces before oil emulsion distemper Paints are applied on them. The cement primer is composed of a medium and pigment which are resistant to the alkalies present in the cement, lime or lime cement in wall finish and provides a barrier for the protection of subsequent coats of oil emulsion distemper Paints.

Primer coat shall be preferably applied by brushing and not by spraying. Hurried priming shall be avoided particularly on absorbent surfaces. New plaster patches in old work should also be treated with cement primer before applying oil emulsion Paints etc.

**13.20.1 Preparation of the Surface**

The surface shall be thoroughly cleaned of dust, old white or colour wash by washing and scrubbing. The surface shall then be allowed to dry for at least 48 hours. It shall then be sand papered to give a smooth and even surface. Any unevenness shall be made good by applying putty, made of plaster of paris mixed with water on the entire surface including filling up the undulations and then sand papering the same after it is dry.

**13.20.2 Application**

The cement primer shall be applied with a brush on the clean dry and smooth surface. Horizontal strokes shall be given first and vertical strokes shall be applied immediately afterwards. This entire operation will constitute one coat. The surface shall be finished as uniformly as possible leaving no brush marks. It shall be allowed to dry for at least 48 hours, before oil emulsion Paint is applied.

**13.20.3** The Specifications in respect of scaffolding, protective measures, measurements and rate shall be as described under 13.1.4.

**13.21 CEMENT PAINT**

**13.21.1 Material**

The cement Paint shall be (conforming to IS 5410) of approved brand and manufacture.

The cement Paint shall be brought to the site of work by the contractor in its original containers in sealed condition. The material shall be brought in at a time in adequate quantities to suffice for the whole work or at least a fortnight's work. The materials shall be kept in the joint custody of the Contractor and the Engineer-in-Charge. The empty containers shall not be removed from the site of work till the relevant item of the work has been completed and permission obtained from the Engineer-in-Charge.

**13.21.2 Preparation of Surface**

For New Work, the surface shall be thoroughly cleaned of all mortar dropping, dirt dust, algae, grease and other foreign matter by brushing and washing. Pitting in plaster shall be made good and a coat of water proof cement Paint shall be applied over patches after wetting them thoroughly.

### **13.21.3 Preparation of Mix**

Cement Paint shall be mixed in such quantities as can be used up within an hour of its mixing as otherwise the mixture will set and thicken, affecting flow and finish. Cement Paint shall be mixed with water in two stages. The first stage shall comprise of 2 parts of cement Paint and one part of water stirred thoroughly and allowed to stand for 5 minutes. Care shall be taken to add the cement Paint gradually to the water and not *vice versa*. The second stage shall comprise of adding further one part of water to the mix and stirring thoroughly to obtain a liquid of workable and uniform consistency. In all cases the manufacturer's instructions shall be followed meticulously.

The lids of cement Paint drums shall be kept tightly closed when not in use, as by exposure to atmosphere the cement Paint rapidly becomes air set due to its hygroscopic qualities.

In case of cement Paint brought in gunny bags, once the bag is opened, the contents should be consumed in full on the day of its opening. If the same is not likely to be consumed in full, the balance quantity should be transferred and preserved in an airtight container to avoid its exposure to atmosphere.

### **13.21.4 Application**

**13.21.4.1** The solution shall be applied on the clean and wetted surface with brushes or spraying machine. The solution shall be kept well stirred during the period of application. It shall be applied on the surface which is on the shady side of the building so that the direct heat of the sun on the surface is avoided. The method of application of cement Paint shall be as per manufacturer's specification. The completed surface shall be watered after the day's work.

**13.21.4.2** The second coat shall be applied after the first coat has been set for at least 24 hours. Before application of the second or subsequent coats, the surface of the previous coat shall not be wetted.

**13.21.4.3** For new work, the surface shall be treated with three or more coats of water proof cement Paint as found necessary to get a uniform shade.

**13.21.4.4** For old work, the treatment shall be with one or more coats as found necessary to get a uniform shade.

### **13.21.5 Precaution**

Water proof cement Paint shall not be applied on surfaces already treated with white wash, colour wash, distemper dry or oil bound, varnishes, Paints etc. It shall not be applied on gypsums, wood and metal surfaces.

If water proofing cement is required to be applied on existing surface, previously treated with white wash, colour wash etc., the surface shall be thoroughly cleaned by scrapping off all the white wash, colour wash etc. completely. Thereafter, a coat of cement primer shall be applied followed by two or more coat of water proof cement.

**13.21.6** The specifications in respect of scaffolding, protective measures, measurements and rate shall be as described under 13.14. The coefficient for cement Paint on RCC Jalli shall be the same as provided in Sl. No. 7 of Table 1 under para 13.23.6.4 for painting trellis for Jaffri work.

## **13.22 EXTERIOR PAINTING ON WALL**

### **13.22.1 Material**

The paint shall be (Textured exterior paint/Acrylic smooth exterior paint/premium acrylic smooth exterior paint/100% premium acrylic emulsion paint) of approved brand and manufacture.

This paint shall be brought to the site of work by the contractor in its original containers in sealed condition. The material shall be brought in at a time in adequate quantities to suffice for the whole work or at least a fortnight's work. The materials shall be kept in the joint custody of the contractor and the Engineer-in- Charge. The empty containers shall not be removed from the site of work till the relevant item of work has been completed and permission obtained from the Engineer-in-Charge.

### **13.22.2 Preparation of Surface**

For new work, the surface shall be thoroughly cleaned off all mortar dropping, dirt dust, algae, fungus or moth, grease and other foreign matter of brushing and washing, pitting in plaster shall make good, surface imperfections such as cracks, holes etc. should be repaired using white cement. The prepared surface shall have received the approval of the Engineer in charge after inspection before painting is commenced.

### **13.22.3 Application**

Base coat of water proofing cement paint

**13.22.3.1** All specifications in respect of base coat of water proofing cement paint shall be as described under 13.21.

**13.22.3.2** Before pouring into smaller containers for use, the paint shall be stirred thoroughly in its container, when applying also the paint shall be continuously stirred in the smaller containers so that its consistency is kept uniform. Dilution ratio of paint with potable water can be altered taking into consideration the nature of surface climate and as per recommended dilution given by manufacturer. In all cases, the manufacturer's instructions & directions of the Engineer-in-charge shall be followed meticulously.

The lids of paint drums shall be kept tightly closed when not in use as by exposure to atmosphere the paint may thicken and also be kept safe from dust.

**13.22.3.3** Paint shall be applied with a brush on the cleaned and smooth surface. Horizontal strokes shall be given, First and vertical strokes shall be applied immediately afterwards. This entire operation will constitute one coat. The surface shall be finished as uniformly as possible leaving no brush marks.

**13.22.4** The specifications in respect of scaffolding, protective measures, measurements and rate shall be as described under 13.14.

## **13.22A DELUXE MULTI SURFACE PAINT FOR INTERIORS AND EXTERIORS**

### **13.22A.1 Material**

The paint shall be (Deluxe multi surface paint for interiors and exteriors) of approved brand and manufacture.

This paint shall be brought to the site of work by the contractor in its original containers in sealed condition. The material shall be brought in at a time in adequate quantities to suffice for the whole work or at least a fortnight's work. The materials shall be kept in the joint custody of the contractor and the Engineer-in- Charge. The empty containers shall not be removed from the site of work till the relevant item of work has been completed and permission obtained from the Engineer-in-Charge.

### **13.22A.2 Preparation of Surface**

For new work, the surface shall be thoroughly cleaned off all mortar dropping, dirt dust, algae, fungus or moth, grease and other foreign matter of brushing and washing, pitting in plaster shall make good, surface imperfections such as cracks, holes etc. should be repaired using white cement. The prepared surface shall have received the approval of the Engineer in charge after inspection before painting is commenced.

### **13.22A.3 Application**

Base coat of special primer of same manufacturer shall be used.

**13.22A.3.1** All specifications in respect of base coat of water proofing cement paint shall be as described under 13.21.

**13.22A.3.2** Before pouring into smaller containers for use, the paint shall be stirred thoroughly in its container, when applying also the paint shall be continuously stirred in the smaller containers so that its consistency is kept uniform. Dilution ratio of paint with potable water can be altered taking into consideration the nature of surface climate and as per recommended dilution given by manufacturer. In all cases, the manufacturer's instructions & directions of the Engineer-in-charge shall be followed meticulously.

The lids of paint drums shall be kept tightly closed when not in use as by exposure to atmosphere the paint may thicken and also be kept safe from dust.

**13.22A.3.3** Paint shall be applied with a brush on the cleaned and smooth surface. Horizontal strokes shall be given, First and vertical strokes shall be applied immediately afterwards. This entire operation will constitute one coat. The surface shall be finished as uniformly as possible leaving no brush marks.

**13.22A.4** The specifications in respect of scaffolding, protective measures, measurements and rate shall be as described under 13.14.

## **13.23 PAINTING**

### **13.23.1 Materials**

Paints, oils, varnishes etc. of approved brand and manufacture shall be used. Only ready mixed Paint (Exterior grade) as received from the manufacturer without any admixture shall be used.

If for any reason, thinning is necessary in case of ready mixed Paint, the brand of thinner recommended by the manufacturer or as instructed by the Engineer-in-Charge shall be used.

Approved Paints, oil or varnishes shall be brought to the site of work by the contractor in their original containers in sealed condition. The material shall be brought in at a time in adequate quantities to suffice for the whole work or at least a fortnight's work. The materials shall be kept in the joint custody of the contractor and the Engineer-in -Charge. The empties shall not be removed from the site of work, till the relevant item of work has been completed and permission obtained from the Engineer-in-Charge.

### **13.23.2 Commencing Work**

Painting shall not be started until the Engineer -in-Charge has inspected the items of work to be painted, satisfied himself about their proper quality and given his approval to commence the painting work. Painting of external surface should not be done in adverse weather condition like hail storm and dust storm.

Painting, except the priming coat, shall generally be taken in hand after practically finishing all other building work.

The rooms should be thoroughly swept out and the entire building cleaned up, at least one day in advance of the Paint work being started.

### **13.23.3 Preparation of Surface**

The surface shall be thoroughly cleaned and dusted off. All rust, dirt, scales, smoke splashes, mortar droppings and grease shall be thoroughly removed before painting is started. The prepared surface shall have received the approval of the Engineer-in-Charge after inspection, before painting is commenced.

### **13.23.4 Application**

**13.23.4.1** Before pouring into smaller containers for use, the Paint shall be stirred thoroughly in its containers, when applying also, the Paint shall be continuously stirred in the smaller containers so that its consistency is kept uniform.

**13.23.4.2** The painting shall be laid on evenly and smoothly by means of crossing and laying off, the latter in the direction of the grains of wood. The crossing and laying off consists of covering the area over with Paint, brushing the surface hard for the first time over and then brushing alternately in opposite direction, two or three times and then finally brushing lightly in a direction at right angles to the same. In this process, no brush marks shall be left after the laying off is finished. The full process of crossing and laying off will constitute one coat.

**13.23.4.3** Where so stipulated, the painting shall be done by spraying. Spray machine used may be (a) high pressure (small air aperture) type, or (b) a low pressure (large air gap) type, depending on the nature and location of work to be carried out. Skilled and experienced workmen shall be employed for this class of work. Paints used shall be brought to the requisite consistency by adding a suitable thinner.

**13.23.4.4** Spraying should be done only when dry condition prevails. Each coat shall be allowed to dry out thoroughly and rubbed smooth before the next coat is applied. This should be facilitated by thorough ventilation. Each coat except the last coat, shall be lightly rubbed down with sand paper or fine pumice stone and cleaned off dust before the next coat is laid.

**13.23.4.5** No left over Paint shall be put back into the stock tins. When not in use, the containers shall be kept properly closed.

**13.23.4.6** No hair marks from the brush or clogging of Paint puddles in the corners of panels, angles of mouldings etc. shall be left on the work.

**13.23.4.7** In painting doors and windows, the putty round the glass panes must also be painted but care must be taken to see that no Paint stains etc. are left on the glass. Tops of shutters and surfaces in similar hidden locations shall not be left out in painting. However, bottom edge of the shutters where the painting is not practically possible, need not be done nor any deduction on this account will be done but two coats of primer of approved make shall be done on the bottom edge before fixing the shutters.

**13.23.4.8** On painting steel work, special care shall be taken while painting over bolts, nuts, rivets overlaps etc.

**13.23.4.9** The additional specifications for primer and other coats of Paints shall be as according to the detailed specifications under the respective headings.

### **13.23.5 Brushes and Containers**

After work, the brushes shall be completely cleaned of Paint and linseed oil by rinsing with turpentine. A brush in which Paint has dried up is ruined and shall on no account be used for painting work. The containers when not in use, shall be kept closed and free from air so that Paint does not thicken and also shall be kept safe from dust. When the Paint has been used, the containers shall be washed with turpentine and wiped dry with soft clean cloth, so that they are clean, and can be used again.

### **13.23.6 Measurements**

**13.23.6.1** The length and breadth shall be measured correct to a cm. The area shall be calculated in sqm (correct to two places of decimal), except otherwise stated.

**13.23.6.2** Small articles not exceeding 10 sq. decimetre (0.1 sqm) of painted surfaces where not in conjunction with similar painted work shall be enumerated.

**13.23.6.3** Painting upto 10 cm in width or in girth and not in conjunction with similar painted work shall be given in running metres and shall include cutting to line where so required.

**Note :** Components of trusses, compound girders, stanchions, lattices and similar work shall, however, be given in sq. metres irrespective of the size or girth of members. Priming coat of painting shall be included in the work of fabrication.

**13.23.6.4** In measuring painting, varnishing, oiling etc. of joinery and steel work etc. The coefficients as indicated in following tables shall be used to obtain the area payable. The coefficients shall be applied to the areas measured flat and not girthed.



**TABLE 13.1**  
**Equivalent Plain Areas of Uneven Surface**

| S.No                                      | Description of work  | How measured   | Multiplying coefficient      |
|---|--|--|------------------------------|
| 1   | 2  | 3  | 4                            |
| <b>I. Wood work doors, windows Etc.</b>   |  |  |                              |
| 1.  | Panelled or framed and braced doors, windows etc.  | Measured flat (not girthed including)  | 1.30 (for each side)         |
| 2.  | Ledged and battened or ledged, battened and braced doors, windows etc.                                   | Chowkhat or frame, Edges, chocks, cleats, etc. shall be deemed to be included in the item.                             | -do-                         |
| 3.  | Flush doors etc.   | -do-   | 1.20 (for each side)         |
| 4.  | Part panelled and part glazed or gauzed doors, window etc. (Excluding painting of wire gauze portion)    | -do-   | 1.00 (for each side)         |
| 5.  | Fully glazed or gauzed doors, windows etc. (Excluding painting of wire gauze portion)                    | -do-   | 0.80 (for each side)         |
| 6.  | Fully venetioned or louvered doors, windows etc.   | -do-   | 1.80 (for each side)         |
| 7.  | Trellis (or Jaffri) work one way or two way  | Measured flat overall, no deduction shall be made for open spaces, supporting members shall not be measured separately | 2 (for painting all over)    |
| 8.  | Carved or enriched work  | Measured flat  |                              |
| 9.  | Weather boarding   | Measured flat (not girthed supporting frame work shall not be measured separately                                      | 1.20 (for each side)         |
| 10.                                       | Wood shingle roofing   | Measured flat (not girthed)  | 1.10 (for each side)         |
| 11.                                       | Boarding with cover fillets and match boarding   | Measured flat (not girthed)  | 1.05 (for each side)         |
| 12.                                       | Tile and slate battening   | Measured flat overall no deductions shall be made for open spaces  | 0.80 (for painting all over) |
| <b>II. Steel work doors, windows Etc.</b> |  |  |                              |
| 13.                                       | Plain sheeted steel doors or windows   | Measured flat (not girthed) including frame edges etc.   | 1.10 (for each side)         |
| 14.                                       | Fully glazed or gauzed steel doors and windows (excluding painting of wire gauze portion)                | -do-   | 0.50 (for each side)         |
| 15.                                       | Partly panelled and partly glazed or gauzed doors and windows (excluding painting of wire gauze portion) | -do-   | 0.80 (for each side)         |
| 16.                                       | Corrugated sheeted steel doors or windows  | -do-   | 1.25 (for each side)         |



|                     |  |   |                              |
|---------------------|--|---|------------------------------|
| 17.                 | Collapsible gates  | Measured flat   | 1.50 (for painting all over) |
| 18.                 | Rolling shutters of interlocked laths  | Measured flat (size of opening) all over; jamb guides, bottom rails and locking arrangement etc. shall be included in the item (top cover shall be measured separately) | 1.10 (for each side)         |
| <b>III. General</b> |  |   |                              |
| 19.                 | Expanded metal, hard drawn steel wire fabric of approved quality, grill works and gratings in guard bars, balustrades, railing partitions and MS Bars in windows frames. | Measured flat overall; no deduction shall be made for open spaces; supporting members shall not be measured separately  | 1 (for Paint all over)       |
| 20.                 | Open palisade fencing and gates including standards, braces, rails stays etc. in timber or steel   | -do-<br>(See note No.12)  | 1 (for Paint all over)       |
| 21.                 | Corrugated iron sheeting in roofs, side cladding etc.  | -do-<br>Measured flat (not girthed)   | 1.14 (for each side)         |
| 22.                 | AC corrugated sheeting in roofs, side cladding etc.  | -do-  | 1.20 (for each side)         |
| 23.                 | AC semi corrugated sheeting in roofs, side cladding etc. or Nainital pattern using plain sheets  | -do-  | 1.10 (for each side)         |
| 24.                 | Wire gauze shutters including painting of wire gauze   | -do-  | 1.00 (for each side)         |
| 25.                 | Hait Cut Bamboo fencing  | -do-  | 1.38 (AV) (for each side)    |

#### **Explanatory Notes for Table 13.1**

- (1) Measurements for doors windows etc., shall be taken flat (and not girthed) over all including chowkhuts or frames, where provided. Where Chowkhuts or frames are not provided, the shutter measurements shall be taken.
- (2) Where doors, windows etc., are of composite types other than those included in Table 1 the different portion shall be measured separately with their appropriate coefficients, the centre line of the common rail being taken as the dividing line between the two portions.
- (3) The coefficients for door and windows shall apply irrespective of the size of frames and shutter members.
- (4) In case steel frames are used the area of doors, windows shutters shall be measured flat excluding frames.
- (5) When the two faces of a door, window etc. are to be treated with different specified finishes, measurable under separate items, the edges of frames and shutters shall be treated with the one or the other type of finish as ordered by the Engineer-in-Charge and measurement of this will be deemed to be included in the measurement of the face treated with that finish.
- (6) In the case where shutters are fixed on both faces of the frames, the measurement for the door frame and shutter on one face shall be taken in the manner already described, while the additional shutter on the other face will be measured for the shutter only excluding the frame.

- (7) Where shutters are provided with clearance at top or/and bottom each exceeding 15 cm height, such openings shall be deducted from the overall measurements and relevant coefficient shall be applied to obtain the area payable.
- (8) Collapsible gates shall be measured for width from outside to outside of gate in its expanded position and for height from bottom to top of channel verticals. No separate measurements shall be taken for the top and bottom guide rails rollers, fittings etc.
- (9) Coefficients for sliding doors shall be the same as for normal types of doors in the table. Measurements shall be taken outside to outside of shutters, and no separate measurements shall be taken for the painting guide rails, rollers, fittings etc.
- (10) Measurements of painting as above shall be deemed to include painting all iron fittings in the same or different shade for which no extra will be paid.
- (11) The measurements of guard bars, expanded metal, hard drawn steel wire fabric of approved quality, grill work and gratings, when fixed in frame work, painting of which is once measured else where shall be taken exclusive of the frames. In other cases the measurements shall be taken inclusive of the frames.
- (12) For painting open palisade fencing and gates etc., the height shall be measured from the bottom of the lowest rail, if the palisades do not go below it, (or from the lower end of the palisades, if they project below the lowest rail), upto the top of rails or palisades whichever are higher, but not up to the top of standards when the latter are higher than the top rails or the palisades.

**13.23.6.5** Width of moulded work of all other kinds, as in hand rails, cornices, architraves shall be measured by girth.

**13.23.6.6** For trusses, compound girders, stanchions, lattice girders, and similar work, actual areas will be measured in sq. metre and no extra shall be paid for painting on bolt heads, nuts, washers etc. even when they are picked out in a different tint to the adjacent work.

**13.23.6.7** Painting of rain water, soil, waste, vent and water pipes etc. shall be measured in running metres of the particular diameter of the pipe concerned. Painting of specials such as bends, heads, branches, junctions, shoes, etc. shall be included in the length and no separate measurements shall be taken for these or for painting brackets, clamps etc.

**13.23.6.8** Measurements of wall surfaces and wood and other work not referred to already shall be recorded as per actual.

**13.23.6.9** Flag staffs, steel chimneys, aerial masts, spires and other such objects requiring special scaffolding shall be measured separately.

### **13.23.7 Precautions**

All furnitures, fixtures, glazing, floors etc. shall be protected by covering and stains, smears, splashings, if any shall be removed and any damages done shall be made good by the contractor at his cost.

### **13.23.8 Rate**

Rates shall include cost of all labour and materials involved in all the operations described above and in the particular specifications given under the several items.

## **13.24 PAINTING PRIMING COAT ON WOOD, IRON OR PLASTERED SURFACES**

### **13.24.1 Primer**

**13.24.1.1** The primer for wood work, iron work or plastered surface shall be as specified in the description of item.

**13.24.1.2** Primer for plaster/wood work/Iron & Steel/Aluminium surfaces shall be as specified below:

**TABLE 13.2**

| S.No | Surfaces  | Primer to be used                                 |
|------|---|---|
| 1.   | Wood work (hard and soft wood)  | Pink conforming to IS 3536                        |
| 2.   | Resinour wood and plywood   | Aluminium primer conforming to IS 3585            |
| 3.   | (A) Aluminium and light alloys  | Zinc chromate primer conforming to IS 104         |
|      | (B) Iron, Steel and Galvanized steel  | Red Oxide Zinc chromate Primer conforming IS 2074 |
| 4.   | Cement/Conc/RCC/brick work, Plastered surfaces, non-asbestos surfaces to receive Oil bound distemper or Paint finish. | Cement primer conforming to IS 109                |

**13.24.1.3** The primer shall be ready mixed primer of approved brand and manufacture.

**13.24.1.4** Where primer for wood work is specified to be mixed at site, it shall be prepared from a mixture of red lead, white lead and double boiled linseed oil in the ratio of 0.7 kg : 0.7 kg : 1 litre.

**13.24.1.5** Where primer for steel work is specified to be mixed at site, it shall be prepared from a mixture of red lead, raw linseed oil and turpentine in the ratio of 2.8 kg : 1 litre : 1 litre.

**13.24.1.6** The specifications for the base vehicle and thinner for mixed on site primer shall be as follows:

- (a) *White Lead* : The White lead shall be pure and free from adulterants like barium sulphate and whiting. It shall conform to IS 103.
- (b) *Red Lead* : This shall be in powder form and shall be pure and free from adulterants like brick dust etc. It shall conform to IS 102.
- (c) *Raw Linseed Oil* : Raw linseed oil shall be lightly viscous but clear and of yellowish colour with light brown tinge. Its specific gravity at a temperature of 30 degree C shall be between 0.923 and 0.928.

**Note** : The oil shall be mellow and sweet to the taste with very little smell. The oil shall be of sufficiently matured quality. Oil turbid or thick, with acid and bitter taste and rancid odour and which remains sticky for a considerable time shall be rejected. The oil shall conform in all respects to IS 75. The oil shall be of approved brand and manufacture.

- (d) *Double Boiled Linseed Oil* : This shall be more viscous than the raw oil, have a deeper colour and specific gravity between 0.931 and 0.945 at a temperature of 30 degree C. It shall dry with a glossy surface. It shall conform in all respects to IS 77. The oil shall be of approved brand and manufacture.

**Turpentine** : Mineral turpentine i.e. petroleum distillate which has the same rate of evaporation as vegetable turpentine (distillate product of oleoresin of conifers) shall be used. It shall have no grease or other residue when allowed to evaporate. It shall conform to IS 533.

**13.24.1.7** All the above materials shall be of approved manufacture and brought to site in their original packing in sealed condition.

### **13.24.2 Preparation of Surface**

**13.24.2.1 Wooden Surface** : The wood work to be painted shall be dry and free from moisture.

The surface shall be thoroughly cleaned. All unevenness shall be rubbed down smooth with sand paper and shall be well dusted. Knots, if any shall be covered with preparation of red lead made by grinding red lead in water and mixing with strong glue sized and used hot. Appropriate filler material conforming to IS 345 with same shade as Paint shall be used where specified. The surface treated

for knotting shall be dry before Paint is applied. After obtaining approval of Engineer-in-Charge for wood work, the priming coat shall be applied before the wood work is fixed in position. After the priming coat is applied, the holes and indentation on the surface shall be stopped with glazier's putty or wood putty. Stopping shall not be done before the priming coat is applied as the wood will absorb the oil in stopping and the latter is therefore liable to crack.

**13.24.2.2 Iron & Steel Surface :** All rust and scales shall be removed by scrapping or by brushing with steel wire brushes. Hard skin of oxide formed on the surface of wrought iron during rolling which becomes loose by rusting, shall be removed.

All dust and dirt shall be thoroughly wiped away from the surface.

If the surface is wet, it shall be dried before priming coat is undertaken.

**13.24.2.3 Plastered Surface :** The surface shall ordinarily not be painted until it has dried completely. Trial patches of primer shall be laid at intervals and where drying is satisfactory, painting shall then be taken in hand. Before primer is applied, holes and undulations, shall be filled up with plaster of paris and rubbed smooth.

### **13.24.3 Application**

The primer shall be applied with brushes, worked well into the surface and spread even and smooth.

The painting shall be done by crossing and laying off as described in 13.22.3.3.

### **13.24.4 Treatment on Steel for Aggressive Environment**

**13.24.4.1** A second coat of ready mixed red oxide zinc chromate primer may be applied where considered necessary in aggressive environment such as near Industrial Establishment and Coastal regions where the steel members are prone to corrosion. The second coat (which shall be paid for separately) is to be applied after placing the member in position and just before applying Paint. The second coat of primer is not necessary in case of painting with synthetic enamel Paint as it is applied over an under coat of ordinary Paint.

**13.24.4.2** The specifications described under 13.33 shall hold good so far as they are applicable.

### **13.24A EPOXY PAINT**

#### **13.24A.1 Material**

This product has got excellent adhesion properties and offers a balanced aesthetic and corrosion protective surface. Epoxy offers good resistance to water and humidity. Epoxy coating are used because of their outstanding chemical resistance, durability, low porosity and strong bond strength and it provides dry tough and protective coatings. Epoxy coatings are created, by chemical reaction using an epoxide resin and polyamine hardener.

#### **13.24A.2 Painting new surface**

**13.24A.2.1** Surface must be dried, cleaned & made free from oil, grease, dirt, dust & all other contaminants that could interfere with adhesion of coating.

#### **13.24A.2.2 Application**

The application of priming coat for relevant steel or cement surface shall be as per the description of para no. 13.24. Epoxy paint is supplied in two parts i.e. (base and hardener). Stir the base and hardener separately. Mix hardener gradually into the base under continuous stirring as per mixing ratio as specified by the manufacturers.

The epoxy paint shall be consumed within the working pot life as specified by the manufacturers. Part mixing should be avoided.

To achieve optimum performance of the product, minimum 2-3 coats by brushing would be required to get the desired dry film thickness (DFT) as specified by the manufacturer. Relative humidity in the environment should preferably be below 85%.

#### **13.24A.2.3 Cleaning**

All equipments/apparatus shall be cleaned immediately after use with thinner especially the hose pipes, gun, all spray equipments etc. All surplus material should be disposed off in compliance with environmental pollution rules etc.

#### **13.24A.2.4 General Safety**

Contact of the product with skin specially with eyes should be avoided. Use of face mask is mandatory during whole process. Proper ventilation is required and all safety procedures and precautions are to be adopted for executing epoxy painting process.

#### **13.24A.2.5 Measurement**

Measurements, Rate and other details shall be as specified in Para 13.23 as far as they are applicable which shall include the cost of all labour and material involved in all operation including priming coat as described above.

### **13.25 PAINTING SYNTHETIC ENAMEL PAINT OVER G.S. SHEETS**

#### **13.25.0 Synthetic enamel**

Paint, suitable for painting over G.S. sheets, of approved brand and manufacture and of the required shade shall be used. New or weathered G.S. sheets shall be painted with a priming coat of one coat of redoxide zinc chromate Paint. Primer shall be applied before fixing sheets in place.

#### **13.25.1 Preparation of Surface**

**13.25.1.1 *Painting New Surface*** : The painting of new G.S. sheets shall not usually be done till the sheets have weathered for about a year. When new sheets are to be painted before they have weathered they shall be treated with a mordant solution prepared by mixing 38 gm of copper acetate in a litre of soft water or 13 gm hydrochloric acid in a solution of 13 gm each of copper chloride, copper nitrate and ammonium chloride dissolved in a litre of soft water. This quantity of solution is sufficient for about 235 sqm. to 280 sqm of area and is applied for ensuring proper adhesion of Paint. The painting with the mordant solution will be paid for separately.

Before painting on new or weathered G.S. sheets, rust patches shall be completely cleaned with coarse emery paper and brush. All grease marks shall also be removed and the surface washed and dried and rusted surface shall be touched with synthetic enamel paint of approved brand, manufacturer and shade.

**13.25.1.2 *Painting Old Surface***: If the old Paint is firm and sound, it shall be cleaned of grease, smoke etc. The surface shall then be rubbed down with sand paper and dusted. Rusty patches shall be cleaned up and touched with synthetic enamel paint.

If the old Paint is blistered and flaked, it shall be completely removed as described in 13.41. Such removal shall be paid for separately and painting shall be treated as on new work.

### **13.25.2 Application**

The number of coats to be applied shall be as in the description of item. In the case of C.G.S. sheets, the crowns of the corrugations shall be painted first and when these get dried the general coat shall be given to ensure uniform finish over the entire surface without the crowns showing signs of thinning.

The second or additional coats shall be applied when the previous coat has dried.

**13.25.3** The specifications described in 13.23 shall hold good so far as they are applicable.

### **13.26 PAINTING CAST IRON RAIN WATER, SOIL, WASTE AND VENT PIPES AND FITTINGS**

**13.26.1** The primer shall be prepared on site or shall be of approved brand and manufacture as specified in the item.

Paint shall be anti-corrosive bitumastic Paint, aluminium Paint or other type of Paint as specified in the description of the item.

#### **13.26.2 Painting New Surface**

**13.26.2.1 Preparation of Surface :** The surface shall be prepared for priming coat as described in 13.24.2.2.

**13.26.2.2 Application :** The number of coat of painting over the priming coat shall be as stipulated in the description of the item. The application of Paint over priming coat shall be carried out as specified in 13.25.

**13.26.2.3 Measurements :** Measurements will be taken over the finished line of pipe including specials etc. in running metres, correct to a cm.

Pipes of different diameters of bore shall be measured and paid for separately.

Specials and fittings such as holder bat clamps, plugs etc. will not be measured separately.

**13.26.2.4 Rate :** The rate shall include the cost of all materials and labour involved in all the operations described above, including painting of all specials and fittings.

**13.26.2.5** Specifications described in 13.22 shall hold good as far as they are applicable.

#### **13.26.3 Painting on Old Surface**

**13.26.3.1** The surface shall be prepared as specified in 13.25.1.2.

**13.26.3.2** The specifications for application shall be as described in 13.22.3.

**13.26.3.3** Measurements, rate and other details shall be as specified in 13.26.2.3.

### **13.27 PAINTING WITH WOOD PRESERVATIVE**

**13.27.1** Oil type wood preservative of specified quality and approved make, conforming to IS 218 shall be used. Generally, it shall be creosote oil type-I or anthracene oil.

#### **13.27.2 Painting on New Surface**

**13.27.2.1 Preparation of Surface :** Painting shall be done only when the surface is perfectly dry to permit of good absorption. All dirt, dust or other foreign matter shall be removed from the surface to be painted. All roughness shall be sand papered and cleaned.

**13.27.2.2 Application :** The preservative shall be applied liberally with a stout brush and not daubed with rags or cotton waste. It shall be applied with a pencil brush at the joints of the wood work. The first coat shall be allowed at least 24 hours to soak in before the second (the final) coat is applied. The second coat shall be applied in the same manner as the first coat. The excess of preservative which does not soak into the wood shall be wiped off with a clean dry piece of cloth.

**13.27.2.3** The specifications described in 13.23 shall hold good in so far as they are applicable.

### **13.27.3 Painting on Old Surface**

The work shall be done in the same manner as on new surface except that only one coat shall be done.

## **13.27A FIRE RETARDANT PAINT**

### **13.27A.1 Material**

Ready to use, intumescent coating which effectively retards the flame spread and penetration of heat through their intumescent sublimative-ablative and synergetic flame suppressing action. On contact with flame, flame control intumescent fire retardant coating, decomposes and puff up (intumesce) forming a thick, dense, spongy foam layer that retards heat penetration and flame spread.

### **13.27A.2 Polishing new surface**

#### **13.27A.2.1 Preparation of surface**

Preparation of surface shall be as described in para 13.23.3. Surface must be dry, free from dust, oil, wax, greases.

#### **13.27A.2.2 Application**

To achieve optimum performance of product apply fire retardant paint @ 2.86 litre/10 sqm per coat or as specified by manufacturers in multiple coats with brush etc. using conventional French polish process to achieve good result.

#### **13.27A.2.3 Measurement**

Measurements, Rate and other details shall be as specified in 13.23 as far as they are applicable.

## **13.28 COAL TARRING**

**13.28.1** Coal tar of approved manufacture conforming to IS 290 shall be used. The tar, to every litre of which 200 gm of unslaked lime has been added, shall be heated till it begins to boil. It must then be taken off the fire and kerosene oil added to it slowly at the rate of one part of kerosene oil to six or more parts by volume and stirred thoroughly. The addition of lime is for preventing the tar from running.

### **13.28.2 Coal Tarring New Surface**

**13.28.2.1 Preparation of Surface :** This shall be done as specified in 13.24.2 except that sand papering is not necessary. Where iron work is to be painted it shall be free from scales and rust before painting.

**13.28.2.2 Application :** The mixture shall be applied as hot as possible with a brush. The second coat shall be applied only after the first coat has thoroughly dried up. Where possible, the article to be tarred, shall be dipped in the hot mixture for better results. The quantity of tar to be used for the first or second coat shall be not less than 0.16 and 0.12 litre per sqm respectively. Thinning with kerosene oil shall be suitably done to ensure this.



**13.28.2.3** The specifications described in 13.23 shall hold good in all other respects, so far as they are applicable.

**13.28.3 Coal Tarring old Surface**

The work shall be done in the same manner as specified in 13.28.2 except that only one coat using 0.12 litre per sqm. area shall be done.

**13.29 SPRAY PAINTING WITH FLAT WALL PAINT ON NEW SURFACE**

**13.29.0** The work shall include a priming coat of 'Distemping Primer' or 'Cement Primer' as specified in the description of the item. Flat wall Paint shall normally be applied on walls 12 months after their completion, in which case Distemper primer will suffice. If the walls are to be painted earlier, the primer coat shall consist of cement primer.

**13.29.1** The primer and the flat wall Paint shall be of approved brand and manufacture and of the required shade.

**13.29.2** The surface shall be prepared as described in 13.20.1.

**13.29.3 Application**

**13.29.3.1 Primer Coat :** The specified primer shall be painted or sprayed over the surface in an even and uniform layer.

**13.29.3.2 Painting Coats :** When the surface is dry, the spray painting with the wall Paint in uniform and even layers will be done to the required number of coats. Each coat shall be allowed to dry overnight and lightly rubbed with very fine grade of sand paper and loose particles brushed off before the next coat is sprayed.

Spraying should be done only when dry condition prevails. During spraying the spray gun shall be held perpendicular to the surface to be coated and shall be passed over the surface in a uniform sweeping motion. Different air pressures and fan adjustment shall be tried so as to obtain the best application. The Air pressure shall not be kept too high as otherwise the Paint will fog up and will be wasted.

At the end of the job, the spray gun shall be cleaned thoroughly so as to be free from dirt. Incorrect adjustments shall be set right, as otherwise they will result in variable spray patterns, runs, sags and uneven coats.

If after the final coat of wall Paints, the surface obtained is not upto the mark, further one or more coats as required shall be given after rubbing down the surface and dusting off all loose particles to obtain a smooth and even finish.

If the primer or wall Paint gets thickened during the application, it shall be thinned suitably with the thinner recommended by the manufacture.

Adequate ventilation shall be provided to disperse spray fumes. Fitments and floor shall be protected from the spray.

**13.29.4** The specifications described in 13.23 shall hold good for all other details as far as applicable.

**13.30 SPRAY PAINTING WITH FLAT PAINT ON OLD SURFACE**

**13.30.0** Where the old Paint is in sound condition, renewal shall be carried out as described below, otherwise the old Paint shall be completely stripped and spray painting shall be carried out as over new work. Such removal shall be paid for separately.



**13.30.1** The flat wall Paint shall be of approved brand and manufacture and of required shade.

**13.30.2 Preparation of Surface**

The surface shall be washed to remove dust and dirt. A mild detergent solution like soap water shall be used for washing and the surface shall also be rubbed down lightly with abrasive paper when dry. Any patches appearing on the surface shall first be touched up with a coat of Paint. These shall be allowed to dry and then rubbed down lightly.

**13.30.3 Application**

The Paint shall then be applied with spraying machine in uniform and even layer. A second coat shall be applied if considered necessary by the Engineer-in-Charge but only after the first coat is complete dry and hard.

Spraying should be done only when dry condition prevails. During spraying the spray gun shall be held perpendicular to the surface to be coated and shall be passed over the surface in uniform sweeping motion. Different air pressures and fan adjustment shall be tried so as to obtain the best application. The Air pressure shall not be kept too high as otherwise the Paint will fog up and will be wasted. At the end of the job, the spray gun shall be cleaned thoroughly so as to be free from dirt. Incorrect adjustments shall be set right, as otherwise they result in variable spray patterns, runs, sags and uneven coats.

**13.30.4** The specifications described in 13.22 shall hold good for all other details, as far as they are applicable.

**13.31 WALL PAINTING WITH PLASTIC EMULSION PAINT**

**13.31.0** The plastic emulsion Paint is not suitable for application on external, wood and iron surface and surfaces which are liable to heavy condensation. These Paints are to be used on internal surfaces except wooden and steel.

**13.31.1** Plastic Emulsion Paint as per IS 5411 of approved brand and manufacture and of the required shade shall be used.

**13.31.2 Painting on New Surface**

**13.31.2.1** The wall surface shall be prepared as specified in 13.23.3.

**13.31.2.2 Application :** The number of coats shall be as stipulated in the item. The Paint will be applied in the usual manner with brush, spray or roller. The Paint dries by evaporation of the water content and as soon as the water has evaporated the film gets hard and the next coat can be applied. The time of drying varies from one hour on absorbent surfaces to 2 to 3 hours on non-absorbent surfaces.

The thinning of emulsion is to be done with water and not with turpentine. Thinning with water will be particularly required for the under coat which is applied on the absorbent surface. The quantity of water to be added shall be as per manufacturer's instructions.

The surface on finishing shall present a flat velvety smooth finish. If necessary more coats will be applied till the surface presents a uniform appearance.

**13.31.2.3 Precautions**

- (a) Old brushes if they are to be used with emulsion Paints, should be completely dried of turpentine or oil Paints by washing in warm soap water. Brushes should be quickly washed in water immediately after use and kept immersed in water during break periods to prevent the Paint from hardening on the brush.

- (b) In the preparation of wall for plastic emulsion painting, no oil base putties shall be used in filling cracks, holes etc.
- (c) Splashes on floors etc. shall be cleaned out without delay as they will be difficult to remove after hardening.
- (d) Washing of surfaces treated with emulsion Paints shall not be done within 3 to 4 weeks of application.

**13.31.2.4** Other details shall be as specified in 13.23 as far as they are applicable.

### **13.31.3 Painting on Old Surface**

**13.31.3.1 Preparation of Surface :** This shall be done, generally as specified in 13.24.2.1 except that the surface before application of Paint shall be flattened well to get the proper flat velvety finish after painting.

**13.31.3.2 Application :** The number of coats to be applied shall be as in description of item.

The application shall be as specified in 13.31.2.2 except that thinning with water shall not normally be required.

**13.31.3.3** Other details shall be as specified in 13.23 as far as applicable.

### **13.32 PAINTING WITH SYNTHETIC ENAMEL PAINT**

**13.32.1** Synthetic Enamel Paint (conforming to IS 2933) of approved brand and manufacture and of the required colour shall be used for the top coat and an undercoat of ordinary Paint of shade to match the top coat as recommended by the same manufacturer as far the top coat shall be used.

### **13.32.2 Painting on New Surface**

**13.32.2.1** Preparation of surface shall be as specified in 13.24.2 as the case may be.

**13.32.2.2 Application :** The number of coats including the undercoat shall be as stipulated in the item.

- (a) *Under Coat* : One coat of the specified ordinary Paint of shade suited to the shade of the top coat, shall be applied and allowed to dry overnight. It shall be rubbed next day with the finest grade of wet abrasive paper to ensure a smooth and even surface, free from brush marks and all loose particles dusted off.
- (b) *Top Coat* : Top coats of synthetic enamel Paint of desired shade shall be applied after the undercoat is thoroughly dry. Additional finishing coats shall be applied if found necessary to ensure properly uniform glossy surface.

**13.32.2.3** Other details shall be as specified in 13.22 as far as they are applicable.

### **13.32.3 Painting on Old Surface**

**13.32.3.1 Preparation of Surface :** Where the existing Paint is firm and sound it shall be cleaned of grease, smoke etc. and rubbed with sand paper to remove all loose particles dusted off. All patches and cracks shall then be treated with stopping and filler prepared with the specified Paint. The surface shall again be rubbed and made smooth and uniform.

If the old paint is blistered and flaked it will be necessary to completely remove the same as described in para 13.41. Such removal shall be paid for separately and the painting shall be treated as on new surface.

**13.32.3.2 Painting :** The number of coats as stipulated in the item shall be applied with synthetic enamel Paint. Each coat shall be allowed to dry and rubbed down smooth with very fine wet abrasive paper, to get an even glossy surface. If however, the surface is not satisfactory additional coats as required shall be applied to get correct finish.

**13.32.3.3** Other details shall be specified in 13.22 as far as they are applicable.

### **13.33 PAINTING WITH ALUMINIUM PAINT**

**13.33.1** Aluminium Paint shall be (conforming to IS 2339) of approved brand and manufacture. The Paint comes in compact dual container with the paste and the medium separately.

The two shall be mixed together to proper consistency before use.

#### **13.33.2 Preparation of Surface**

**13.33.2.1 Steel Work (New Surfaces) :** All rust and scales shall be removed by scraping or brushing with steel wire brushes and then smoothed with sand paper. The surface shall be thoroughly cleaned of dust.

**13.33.2.2 C.G.S. Sheets (New Surfaces) :** The preparation of surface shall be as specified in 13.25.1.1.

**13.33.2.3 Steel Work or C.G.S. sheets (Old Surfaces):** The specifications shall be as described in 13.25.1.2.

#### **13.33.3 Application**

The number of coats to be applied shall be as given in the item. Each coat shall be allowed to dry for 24 hours and lightly rubbed down with fine grade sand paper and dusted off before the next coat is applied. The finished surface shall present an even and uniform appearance.

As aluminium paste is likely to settle in the container, care shall be taken to frequently stir the Paint during used. Also the Paint shall be applied and laid off quickly, as surface is otherwise not easily finished.

**13.33.4** Other details shall be as specified in 13.23 as far as they are applicable.

### **13.34 PAINTING WITH ACID PROOF PAINT**

**13.34.1** Acid proof Paint of approved brand and manufacture and of the required shade shall be used.

**13.34.2** Preparation of surface and application shall be as specified under 13.32 for new/old surface as the case may be.

**13.34.3** Other details shall be as specified in 13.23 as far as they are applicable.

### **13.35 PAINTING WITH ANTI-CORROSIVE BITUMASTIC PAINT**

**13.35.1** Ready mixed Paint (conforming to IS 158) shall be of approved brand and manufacture. It shall be black, lead free, acid-alkali-heat-water resistant.

**13.35.2** Preparation of surface and application shall be as specified in 13.32 for painting on new or old surfaces as the case may be.

The drying time between consecutive coats, however, shall be not less than 3 hours.

**13.35.3** Other details shall be as specified in 13.23 as far as applicable.

### **13.36 FLOOR PAINTING**

**13.36.1** Floor Paint of approved brand and manufacture and of the required colour shall be used.

#### **13.36.2 Preparation of Surface**

All dirt, grease shall be removed from the floor by wiping with rags, soaked in turpentine and scraping where necessary and then washing with warm water, containing caustic soda or washing soda in solution. The floor should then be rinsed thoroughly with water and dried. Cracks and holes shall then be filled with specified filler as recommended by the manufacturer and rubbed smooth.

It should be noted that the painting with floor paints shall not be done over concrete surfaces less than two years old.

Old surface shall be prepared as specified in 13.32.3.1

#### **13.36.3 Application**

The number of coats as in the description of the item shall be applied. Each coat shall be allowed to dry for not less than 24 hours before the next coat is applied. The flooring should not be brought into use for a week after final coat so that the painted surface can thoroughly harden.

#### **13.36.4 Measurement**

Measurements shall be as per actual length and breadth being measured correct to a cm. The details given under 13.23.6 shall hold good as far as applicable.

**13.36.5** Other details shall be as specified in 13.23 as far as applicable.

### **13.37 VARNISHING**

**13.37.0** Ordinary copal varnish or superior quality spray varnish shall be used. The work includes sizing of transparent wood filler.

**13.37.1** Varnish (conforming to IS 347 for the finishing and undercoats shall be of the approved manufacturer.

#### **13.37.2 Varnishing on New Surfaces**

**13.37.2.1 Preparation of Surface** : New wood work to be varnished shall have been finished smooth with a carpenter's plane. Knots shall be cut to a slight depth. Cracks and holes shall be cleaned of dust. The knots, cracks etc. shall then be filled in with wood putty made as follows:

On a piece of wood say 20 x 15 cm face and on the side where cross grains appear, a small quantity of glue size shall be poured and the surface scraped with the edge of a fine carpenter's chisel. Very fine wood powder shall be mixed with the glue and the stiff paste thus formed shall be used for the filling.

The fillings when dry shall be rubbed down with a carpenter's file and then the entire surface shall be rubbed down perfectly smooth with medium grained and fine sand papers and wiped with dry clean cloth so that it presents uniform appearance. In no case shall sand papers be rubbed across the grains, as in this case even the finest marks will be visible when the varnishing is applied.

**13.37.2.2 Sizing or Transparent Wood Filler Coat** : The surface shall then be treated with either glue sizing or with transparent wood filler coat as stipulated in the description of item.

(a) *Sizing* : When sizing is stipulated, an application of thin clean size shall be applied hot on the surface. When dry, the surface shall be rubbed down smooth with sand paper and cleaned.

It shall then be given another application of glue size nearly cold. The sized wood work shall

again be rubbed down smoothly with fine sand paper and cleaned. The surface shall be perfectly dry and all dust shall be removed not only from the surface but also from the edges and joints before varnishing is commenced. If the wood work is to be stained, the staining colour shall be mixed with the second coat of the size which must be applied evenly and quickly keeping the colour on the flow.

Any joining up with work already dry will show badly. The object of application of the glue size is to seal the pores in wood to prevent absorption of the oil in the varnish.

Glue sizing is inadvisable on floors, table tops and other horizontal surfaces likely to carry wet household utensils which are likely to disturb the size coatings and thus expose bare wood.

Where glue sizing is omitted to be done the rate for the work shall be suitably reduced.

(b) *Transparent Wood Filler Coat* : Where instead of glue sizing, transparent wood filler application is stipulated in the item, then the surface prepared as described in 13.37.2.1 shall be given as application of the filler with brush or rag in such a way that the filler fills up all the pores and indentations and levels up the surface. It shall be allowed to dry for 24 hours. Then it shall be cut and rubbed with emery paper so that the surface of the wood is laid bare, with the filler only in the pores and crevices of the wood.

**13.37.2.3 Application of Varnish** : The number of coats to be applied shall be as stipulated in the description of the item.

The undercoat shall be with a flattening varnish. This dries hard and brittle and when cut and rubbed down to produce a smooth surface enhances the gloss of the finishing varnish. The top coat shall be given with stipulated brand of finishing varnish.

The varnish shall be applied liberally with a full brush and spread evenly with short light strokes to avoid frothing. If the work is vertical the varnish shall be crossed and recrossed and then laid off, latter being finished on the upstrokes so that varnish, as it sets, flows down and eliminates brush marks, the above process will constitute one coat. If the surface is horizontal, varnish shall be worked in every direction, with light quick strokes and finish in one definite direction so that it will set without showing brush marks, in handling and applying varnish care should be taken to avoid forming froth or air bubbles. Brushes and containers shall be kept scrupulously clean.

Rubbing down and flattening the surface shall be done after each coat except the final coat with fine sand paper.

The work shall be allowed to dry away from draughts and damp air. The finished surface shall then present a uniform appearance and fine glossy surface free from streaks, blister etc.

Any varnish left over in the small container shall not be poured back into the stock tin, as it will render the latter unfit for use.

Special fine haired varnishing brushes shall be used and not ordinary Paint brushes. Brushes shall be well worn and perfectly clean.

**13.37.2.4** Other details shall be as specified in 13.23 as far as they are applicable.

### **13.37.3 Varnishing on Old Surface**

**13.37.3.1 Preparation of Surface :** If the old varnished surface is firm and sound it shall be cleaned of grease and dirt with turpentine and then rubbed with wet sand paper until the surface is clean and smooth. It shall be dried and wiped clean with a soft cloth. Knots, holes and cracks shall be stopped as specified in 13.37.2.1. The entire surface shall then be rubbed down smooth with sand paper and wiped clean.

If the old varnished surface is peeled or cracked then it will be necessary to remove the entire varnish as described in para 13.41 and such removal shall be paid for separately outside the rate for varnishing. Further the varnishing itself will have to be done like new work and will be paid for as such.

**13.37.3.2 Application :** The specification shall be same as described in 13.37.2.3 as far as applicable except that the coats to be applied will be with the stipulated quality of varnish for finishing coat.

**13.37.3.3** Other details shall be as specified in 13.23 as far as they are applicable.

### **13.37A MELAMINE POLISH**

#### **13.37A.1 Material**

Melamine is an organic compound that is often combined with formaldehyde to produce melamine resin, a synthetic polymer that is fire resistant and heat tolerant. The resin is a versatile material that has a highly stable structure. It is a closed pore polish i.e. it makes the wood **non-breathable product** that protects wood from mainly hot and cold surfaces placed over it.

#### **13.37A.2 Polishing Old Surface**

##### **13.27A.2.1 Preparation of surface**

The surface shall be thoroughly cleaned. All unevenness shall be rubbed down smooth with sand paper and shall be well dusted. Surface must be dry, free from dust, oil, wax, greases etc.

##### **13.27A.2.2 Application**

Mix melamine (matt or gloss) base with the catalyst in the specified ratio as per manufacturers specification. Add melamine thinner upto 30% (as specified by the manufacturer) by volume of mixture. Stir it and allow it to mature for 2-3 minutes. The melamine is sprayed, using spray gun pressure of 45-55 psi, from a distance of 7"-10" from substrate.

Precaution : Avoid eye contact, use of mask is mandatory during whole process.

##### **13.27A.2.3 Measurement**

Measurements, Rate and other details shall be as specified in 13.23 as far as they are applicable.

### **13.38 FRENCH SPIRIT POLISHING**

**13.38.1** Pure shellac conforming to IS 16 varying from pale orange to lemon yellow colour, free from resin or dirt shall be dissolved in methylated spirit at the rate of 140 gm of shellac to 1 litre of spirit. Suitable pigment shall be added to get the required shade. Ready made polish conforming to IS 348 can also be used.

#### **13.38.2 Polishing New Surface**

**13.38.2.1 Preparation of Surface :** The surface shall be cleaned. All unevenness shall be rubbed down smooth with sand paper and well dusted. Knots if visible shall be covered with a preparation of red lead and glue size laid on while hot. Holes and indentations on the surface shall be stopped with glazier's putty. The surface shall then be given a coat of wood filler made by mixing whiting (ground chalk) in methylated spirit at the rate of 1.5 Kg of whiting per litre of spirit. The surface shall again be rubbed down perfectly smooth with glass paper and wiped clean.

**13.38.2.2 Application :** The number of coats of polish to be applied shall be as described in the item.

A pad of woolen cloth covered by a fine cloth shall be used to apply the polish. The pad shall be moistened with the polish and rubbed hard on the wood, in a series of overlapping circles applying the mixture sparingly but uniformly over the entire area to give an even level surface. A trace of linseed oil on the face of the pad facilitates this operation. The surface shall be allowed to dry and the remaining coats applied in the same way. To finish off, the pad shall be covered with a fresh piece of clean fine cotton cloth slightly dampened with methylated spirit and rubbed lightly and quickly with circular motions. The finished surface shall have a uniform texture and high gloss.

**13.38.2.3 Measurements, Rate and other details** shall be as specified in 13.23 as far as they are applicable.

### **13.38.3 Polishing Old Surface**

**13.38.3.1 Preparation of Surface :** If the old polished surface is not much soiled it shall be cleaned of grease and dirt by rubbing with turpentine and then rubbed with fine sand paper.

If the old polished surface is much soiled then it will be necessary to remove the entire polish as described in 13.41 and such removal shall be paid for separately outside the rate of polishing. Further the polishing itself will have to be done like new work and will be paid for as such.

**13.38.3.2 Application :** The specifications shall be same as described in 13.38.2.2 as far as applicable.

**13.38.3.3 Measurements, Rate and other details** shall be as specified in 13.23 as far as they are applicable.

### **13.39 BEES WAXING OR POLISHING WITH READY MADE WAX POLISH**

**13.39.1** The polishing shall be done with bees waxing prepared locally or with readymade wax polish of approved brand and manufacture, as stipulated in the description of item.

Where bees waxing is to be prepared locally, the following specifications for the same shall apply.

Pure bees wax free from paraffin or stearine adulterants shall be used. Its specific gravity shall be 0.965 to 0.969 and melting point shall be 63 degree C. The polish shall be prepared from a mixture of bees wax, linseed oil, turpentine and varnish in the ratio of 2 : 1.5 : 1 : 0.5 by weight.

The bees wax and boiled linseed oil shall be heated over a slow fire. When the wax is completely dissolved the mixture shall be cooled till it is just warm and turpentine and varnish added to it in the required proportions and the entire mixture shall be well stirred.

### **13.39.2 Waxing New Surface**

**13.39.2.1 Preparation of Surface :** Preparation of surface shall be as described in 13.37.2.1 with the exception that knotting, holes and cracks shall be stopped with a mixture of fine saw dust formed of the wood being treated, beaten up with sufficient bees wax to give it cohesion.

**13.39.2.2 Application :** The polish shall be applied evenly with a clean soft pad of cotton cloth in such a way that the surface is completely and fully covered. The surface is then rubbed continuously for half an hour.

When the surface is quite dry, a second coat shall be applied in the same manner and rubbed continuously for one hour or until the surface is dry.

The final coat shall then be applied and rubbed for two hours (more if necessary) until the surface has assumed a uniform gloss and is dry, showing no sign of stickiness.

The final polish depends, largely on the amount of rubbing which should be continuous and with uniform pressure with frequent changes in the direction.

**13.39.2.3** Other details shall be as specified in 13.23 as far as they are applicable.



### **13.39.3 Waxing Old Surfaces**

**13.39.3.1 Preparation of Surface :** The wood work shall be cleaned of all smoke and grease by washing with lime water. The surface shall then be washed with soap and completely dried. Then it shall be prepared smooth as specified in 13.37.2.1.

**13.39.3.2 Application :** The polish shall be applied in the manner specified in 13.39.2.2. In this case one or two coats shall be applied as necessary to get uniform gloss, instead of three coats in the case of new work.

**13.39.3.3** Other details shall be as specified in 13.22 as far as they are applicable.

### **13.40 LETTERING WITH PAINT**

**13.40.1** Black, Japan Paint (conforming to IS 341) or ready mixed Paint as ordered by the Engineer-in-Charge shall be used. The Paint shall be of approved brand and manufacture. Ordinary ready mixed Paint shall be of the shade required by the Engineer-in-Charge.

#### **13.40.2 Lettering on New Surface**

**13.40.2.1 Application :** The letters and figures shall be to the heights and width as ordered by the Engineer-in-Charge. These shall be stenciled or drawn in pencil and got approved before painting. They shall be of uniform size and finished neatly. The edges shall be straight or in pleasant smooth curves. The thickness of the lettering shall be as approved by the Engineer-in-Charge. Lettering shall be vertical or slanting as required.

Two or more coats of Paint shall be applied till uniform colour and glossy finish are obtained.

**13.40.2.2 Measurements :** Measurements shall be taken in terms of letter cm (the measurement relates to the vertical height of the lettering). The letter heights shall be measured correct to a cm. Dots, dashes, punctuations and other similar marks or lines shall not be measured for payment.

In Devanagari Script Dots & Matras occurring with the letters shall not be measured. Half letter shall be measured as full letter. The height of letters shall be measured excluding the Matras projecting above the heading and matras below the letters.

**13.40.2.3 Rate :** Rate shall include the cost of all labour and materials involved in the operations described above. The rate per cm height of letter shall hold good irrespective of the width of the letters or figures or the thickness of the lettering.

The same rate will apply irrespective of whether black Japan or ready mixed Paint of any shade as required is used.

#### **13.40.3 Relettering on Old Surface**

**13.40.3.1** Painting shall be done over the existing letters and shall accurately follow their lines and curves.

One or more coat of Paints shall be applied till a uniform colour and glossy finish is obtained.

**13.40.3.2** Measurements and Rate shall be as specified under 13.40.2.

### **13.41 REMOVING OLD PAINT**

#### **13.41.1 With Patent Paint Remover**

**13.41.1.1** Patent Paint removers shall consist of volatile organic liquids thickened with waxes and other ingredients to retard the evaporation of the liquid and to enable a substantial layer of remover to be applied to the surface. The Paint remover shall be of a brand and manufacture approved by the Engineer-in-Charge. It shall be free from alkaline matter and non-caustic so that it can be handled by workmen without injury. It shall be of non inflammable quality as far as possible.



**13.41.1.2 Application :** Paint remover shall be used where burning off with blow lamp is not suitable. The Paint remover shall be applied liberally with a brush and allowed to remain on the surface for a period depending on the particular brand of remover used and on the thickness of the Paint coating to be removed. When the Paint film lifts and wrinkles under the action of the remover it shall be stripped with a sharp instrument. If the film is not thoroughly removed a second coat of remover may be applied if necessary over such patches and then the film thoroughly scrapped.

After the surface has been stripped, it shall be washed down with mineral turpentine to remove all traces of paraffin wax, which forms one of the ingredients of patent Paint remover and which if left in place will prevent the Paint from drying.

The cleaned surface shall be suitably prepared for application of Paint or other finish.

**13.41.1.3 Precautions :** Where the Paint remover used is of the inflammable type, suitable precaution against risk of fire shall be taken.

Neighbouring painted surfaces which are not to be treated should be properly protected from contact with Paint remover.

**13.41.1.4 Preparation of Surface :** The surface shall then be prepared as described in 13.24.2.

**13.41.1.5 Measurements :** Specification for 13.23.6 shall hold good.

**13.41.1.6 Rate :** Rate shall include the cost of all labour and materials involved in all operations described above.

**13.41.1.7** Other details shall be as specified 13.23 as far as possible.

### **13.41.2 With Caustic Soda Solution**

**13.41.2.1 Application :** Caustic soda dissolved with 48 times its volume of water shall be applied to the old Paint with a brush and when the Paint film lifts and wrinkles it shall be thoroughly scrapped of in the same way as described in 13.41.1.2. After the surface has been stripped thoroughly, it shall be rinsed with several changes of clean water to remove all traces of alkali, which if allowed to remain are liable to spoil the new Paint applied over it. A little acetic acid or vinegar added to the final change of rinsing water helps to neutralize any remaining alkali.

**13.41.2.2 Precautions :** Caustic soda as its name implies is a corrosive liquid and care should be taken to see that no liquid spills over the skin or clothing.

**13.41.2.3** Preparation of Surface, Measurements, Rate and other details shall be as specified under 13.41.1.

### **13.41.3 With Blow Lamp**

**13.41.3.1** The Paint shall be removed either with a blow lamp or with air acetylene equipment. The flame shall be allowed to play upon the Paint just enough to soften it without charring either the Paint or the background. The softened Paint shall then be removed with a stripping knife following the flame as it is moved up the surface.

Burning off shall begin at the bottom of the vertical surface and shall proceed upwards.

**13.41.3.2 Precautions :** Removal with blow lamp shall not be done on narrow or carved under cut surfaces or where there is risk of damage to neighbouring materials such as panes in glazed windows.

**13.41.3.3** Preparation of surface, Measurements, Rate and other details shall be as described under 13.41.1.

Neighbouring painted surfaces which are not to be treated should be properly protected from contact with Paint remover.

## **13.42 WASHED STONE GRIT PLASTER**

**13.42.1** Scaffolding shall be as specified in 13.1.1.

**13.42.2** Preparation of surface shall be as specified in 13.1.2 and 13.4.2.

### **13.42.3 Materials**

**13.42.3.1** Stone chippings obtained by crushing hard stone shall be free of dust and deleterious material. 10 mm nominal size stone chippings, where specified, shall pass 100% through 12.5 mm sieve and fully retained on 6.3 mm sieve. Stone chippings shall be thoroughly washed with water and sieved before use.

**13.42.3.2 Mortar :** Cement mortar for under coat and cement mortar to be mixed with stone chippings for top coat shall be as specified in 3.5.

### **13.42.4 Application of Plaster**

**13.42.4.1 12 mm Under Coat :** Under coat of cement mortar 1:4 (1 cement : 4 coarse sand) shall be applied as specified in 13.1.3 except that the finishing, after the mortar has been brought to level with the wooden straight edge, shall be done with wooden float only. The surface shall be further roughened by furrowing with a scratching tool. Furrowing shall be done diagonally both ways and shall be about 2 mm deep to provide a key for the top coat. The scratched lines shall not be more than 10 cm apart. The surface shall be kept wet till top coat is applied.

**13.42.4.2 15 mm Top Coat :** Top coat comprising cement mortar and stone chippings shall have an overall proportion of 1:0.5:2 (1 cement : 0.5 coarse sand : 2 stone chippings 10 mm nominal size) or as specified. The top coat shall be applied a day or two after the under coat has taken the initial set. The surface of the under coat shall be cleaned and a coat of cement slurry at 2 kg of cement per sqm shall be applied before the application of coat. The top coat shall be applied in uniform thickness on the under coat after the application of slurry and sufficiently pressed with wooden float for proper bonding with the under coat. Vacant space, if any shall be filled with the specified mix.

### **13.42.5 Finish**

The top coat of plaster shall be finished to a true and plumb surface. The surface shall be tested frequently as the work proceeds with a true straight edge not less than 2.5 m long and with plumb bobs. All horizontal lines and surfaces shall be tested with a level and all jambs and corners with a plumb bob as the work proceeds. All the corners angles and junctions shall be truly vertical or horizontal as the case may be. Rounding or chamfering of corners junctions etc. Where required shall be true to template.

Finished surface of the top coat after the mix has taken the initial set, shall be scrubbed and washed with suitable brushes and plain water. Scrubbing and washing shall continue till the stone chippings are sufficiently exposed. Stone chippings which may come out while scrubbing shall be replaced using the specified mortar mix. A sample of the washed stone grit plaster shall be got approved from the Engineer-in-Charge.

#### **13.42.6 Grooves**

Grooves of size 15 mm x 15 mm or as specified shall be provided as shown on the drawing or as required by the Engineer-in-Charge. Tapered wooden battens to match the size and shape of the grooves shall be fixed on the under coat with nails before the application of the top coat and these shall be removed carefully so that the edges of the panels of top coat are not damaged. Damage, if any, shall be made good by the contractor.

#### **13.42.7 Curing**

Curing shall be started 24 hours after finishing the plaster. The plaster shall be kept wet for a period of seven days. During this period, it shall be suitably protected from all damages at the contractor's expense by such means as the Engineer-in-Charge may approve.

#### **13.42.8 Measurements**

**13.42.8.1** Length and breadth shall be measured correct to the nearest cm and the area shall be calculated in sqm correct to two places of decimal.

**13.42.8.2** Measurements shall be taken for the work actually done with deductions for all openings and addition for all jambs soffits and sills. However, no deduction is to be made for the grooves provided as specified in 13.42.6.

**13.42.8.3** Washed stone grit plaster on circular surfaces not exceeding 6 m in radius and on external surfaces at a height greater than 10 m shall be measured separately.

#### **13.42.9 Rates**

The rates shall include the cost of all labour and materials involved in all the operations described above except for providing grooves. The length of grooves shall be measured in running metres and paid for separately.

### **13.43 GYPSUM LIGHT WEIGHT PLASTER**

**13.43.1** Scaffolding shall be as specified in 13.11.

**13.43.2** Preparation of surface shall be as specified in 13.1.2 and 13.4.2.

#### **13.43.3 Materials**

**13.43.3.1** Premixed light weight plasters essentially consist of retarded hemihydrate gypsum plaster and light weight aggregate which are characterized by low density, high thermal insulation and sound absorption properties. Other additions may be incorporated to impart desired properties. The physical and chemical requirements shall conform to IS 2547 (Pt. II).

**13.43.3.2** The minimum recommended water-premixed plaster ratio is 1:2 as per standard practice or as recommended by the manufacturers.

#### **13.43.4 Application of Plaster**

**13.43.4.1** Application of plaster shall be as specified in 13.1.4.1 to 13.1.4.4.

#### **13.43.5 Thickness**

Where the thickness required, as per description of the item is 12 mm, the average thickness of the plaster shall not be less than 12 mm whether wall treated is of brick/block/RCC work.

#### **13.43.6 Finish**

The plaster shall be finished as specified in 13.1.7.

### **13.43.7 Measurement**

Measurement of plaster shall be as specified in 13.1.9.1 to 13.1.9.9.

### **13.43.8 Rate**

Rate shall include the cost of all labour & material involved in all the operations described above.

## **13.44 PAINTING CAST IRON RAIN WATER, SOIL, WASTE AND VENT PIPES AND FITTINGS**

**13.44.1** The primer shall be prepared on site or shall be of approved brand and manufacture as specified in the item.

Paint shall be anti-corrosive bitumastic paint aluminium paint or other type of paint as specified in the description of the item.

### **13.44.2 Painting New Surface**

**13.44.2.1 Preparation of Surface:** The surface shall be prepared for priming coat as described in 13.34.2.2.

**13.44.2.2 Application:** The number of coat of painting over the priming coat shall be as stipulated in the description of the item. The application of paint over priming coat shall be carried out as specified in 13.35.

**13.44.2.3 Measurements:** Measurements will be taken over the finished line of pipe including specials etc. in running metres, correct to a cm.

Pipes of different diameters of bore shall be measured and paid for separately.

Specials and fittings such as holder bat clamps, plugs etc. will not be measured separately.

**13.44.2.4 Rate:** The rate shall include the cost of all materials and labour involved in all the operations described above, including painting of all specials and fittings.

**13.44.2.5** Specifications described in 13.22 shall hold good as far as they are applicable.

### **13.44.3 Painting on Old Surface**

**13.44.3.1** The surface shall be prepared as specified in 13.25.1.2.

**13.44.3.2** The specifications for application shall be as described in 13.25.2.

**13.44.3.3** Measurements, rate and other details shall be as specified in 13.23.6.

**Note: Clause 13.44 brought from Sub Head 14 (Repairs to buildings) clause no 14.24.**

## **13.45 PAINTING WITH WOOD PRESERVATIVE**

**13.45.1** Oil type wood preservative of specified quality and approved make, conforming to IS 218 shall be used. Generally, it shall be creosote oil type-I or anthracene oil.

### **13.45.2 Painting on New Surface**

**13.45.2.1 Preparation of Surface:** Painting shall be done only when the surface is perfectly dry to permit of good absorption. All dirt, dust or other foreign matter shall be removed from the surface to be painted. All roughness shall be sand papered and cleaned.

**13.45.2.2 Application:** The preservative shall be applied liberally with a stout brush and not daubed with rags or cotton waste. It shall be applied with a pencil brush at the joints of the wood work. The first coat shall be allowed at least 24 hours to soak in before the second (the final) coat is applied. The second coat shall be applied in the same manner as the first coat. The excess of preservative which does not soak into the wood shall be wiped off with a clean dry piece of cloth.

**13.45.2.3** The specifications described in 13.23 shall hold good in so far as they are applicable.

### **13.45.3 Painting on Old Surface**

The work shall be done in the same manner as on new surface except that only one coat shall be done.

**Note: Clause 13.45 brought from Sub Head 14 (Repairs to buildings) clause no 14.25**

## **13.46 WALL PAINTING WITH PLASTIC EMULSION PAINT**

**13.46.0** The plastic emulsion paint is not suitable for application on external, wood and iron surface and surfaces which are liable to heavy condensation. These paints are to be used on internal surfaces except wooden and steel.

**13.46.1** Plastic emulsion paint as per IS 5411 of approved brand and manufacture and of the required shade shall be used.

### **13.46.2 Painting on New Surface**

**13.46.2.1** The wall surface shall be prepared as specified in 13.31.

**13.46.2.2 Application :** The number of coats shall be as stipulated in the item. The paint will be applied in the usual manner with brush, spray or roller. The paint dries by evaporation of the water content and as soon as the water has evaporated the film gets hard and the next coat can be applied. The time of drying varies from one hour on absorbent surfaces to 2 to 3 hours on non-absorbent surfaces.

The thinning of emulsion is to be done with water and not with turpentine. Thinning with water will be particularly required for the under coat which is applied on the absorbent surface. The quantity of water to be added shall be as per manufacturer's instructions.

The surface on finishing shall present a flat velvety smooth finish. If necessary more coats will be applied till the surface presents a uniform appearance.

### **13.46.2.3 Precautions**

- (a) Old brushes if they are to be used with emulsion paints, should be completely dried of turpentine or oil paints by washing in warm soap water.  
Brushes should be quickly washed in water immediately after use and kept immersed in water during break periods to prevent the paint from hardening on the brush.
- (b) In the preparation of wall for plastic emulsion painting, no oil base putties shall be used in filling cracks, holes etc.
- (c) Splashes on floors etc. shall be cleaned out without delay as they will be difficult to remove after hardening.
- (d) Washing of surfaces treated with emulsion paints shall not be done within 3 to 4 weeks of application.

**13.46.2.4** Other details shall be as specified in 13.23 as far as they are applicable.

### **13.46.3 Painting on Old Surface**

**13.46.3.1 Preparation of Surface :** This shall be done, generally as specified in 13.31.3.1 except that the surface before application of paint shall be flattened well to get the proper flat velvety finish after painting.

**13.46.3.2 Application :** The number of coats to be applied shall be as in description of item.

The application shall be as specified in 13.31.3.2 except that thinning with water shall not normally be required.

**13.46.3.3** Other details shall be as specified in 13.23 as far as applicable.

**Note: Clause 13.46 brought from Sub Head 14 (Repairs to buildings) clause no 14.26**

### **13.47 PAINTING WITH SYNTHETIC ENAMEL PAINT**

**13.47.1** Synthetic enamel paint (conforming to IS 2932) of approved brand and manufacture and of the required colour shall be used for the top coat and an undercoat of ordinary paint of shade to match the top coat as recommended by the same manufacturer as far the top coat shall be used.

#### **13.47.2 Painting on New Surface**

**13.47.2.1** Preparation of surface shall be as specified in 13.25.1.1 as the case may be.

**13.47.2.2 Application :** The number of coats including the undercoat shall be as stipulated in the item.

(a) *Under Coat :* One coat of the specified ordinary paint of shade suited to the shade of the top coat, shall be applied and allowed to dry overnight. It shall be rubbed next day with the finest grade of wet abrasive paper to ensure a smooth and even surface, free from brush marks and all loose particles dusted off.

(b) *Top Coat :* Top coats of synthetic enamel paint of desired shade shall be applied after the undercoat is thoroughly dry. Additional finishing coats shall be applied if found necessary to ensure properly uniform glossy surface.

**13.47.2.3** Other details shall be as specified in 13.23 as far as they are applicable.

#### **13.47.3 Painting on Old Surface**

**13.47.3.1 Preparation of Surface :** Where the existing paint is firm and sound it shall be cleaned of grease, smoke etc. and rubbed with sand paper to remove all loose particles dusted off. All patches and cracks shall then be treated with stopping and filler prepared with the specified paint. The surface shall again be rubbed and made smooth and uniform.

If the old paint is blistered and flaked it will be necessary to completely remove the same as described in para 13.41. Such removal shall be paid for separately and the painting shall be treated as on new surface.

**13.47.3.2 Painting :** The number of coats as stipulated in the item shall be applied with synthetic enamel paint. Each coat shall be allowed to dry and rubbed down smooth with very fine wet abrasive paper, to get an even glossy surface. If however, the surface is not satisfactory additional coats as required shall be applied to get correct finish.

**13.47.3.3** Other details shall be specified in 13.23 as far as they are applicable.

**Note: Clause 13.47 brought from Sub Head 14 (Repairs to buildings) clause no 14.28**

### **13.48 PAINTING WITH ALUMINIUM PAINT**

**13.48.1** Aluminium paint shall be (conforming to IS 2339) of approved brand and manufacture. The paint comes in compact dual container with the paste and the medium separately.

The two shall be mixed together to proper consistency before use.

#### **13.48.2 Preparation of Surface**

**13.48.2.1 Steel Work (New Surfaces)** : All rust and scales shall be removed by scraping or brushing with steel wire brushes and then smoothed with sand paper. The surface shall be thoroughly cleaned of dust.

**13.48.2.2 C.G.S. Sheets (New Surfaces)** : The preparation of surface shall be as specified in 13.33.2.

**13.48.2.3 Steel Work or C.G.S. Sheets (Old Surfaces)**: The specifications shall be as described in 13.33.2.3.

#### **13.48.3 Application**

The number of coats to be applied shall be as given in the item. Each coat shall be allowed to dry for 24 hours and lightly rubbed down with fine grade sand paper and dusted off before the next coat is applied. The finished surface shall present an even and uniform appearance.

As aluminium paste is likely to settle in the container, care shall be taken to frequently stir the paint during used. Also the paint shall be applied and laid off quickly, as surface is otherwise not easily finished.

**Note: Clause 13.48 brought from Sub Head 14 (Repairs to buildings) clause no 14.29**



**SUB HEAD : 14.0**

**REPAIRS TO BUILDINGS**



## CONTENTS

| <i>Clause No.</i> | <i>Brief Description</i>   | <i>Page No.</i> |
|-------------------|--|-----------------|
|                   | List of Bureau of Indian Standards Codes   | 687             |
| 14.1              | Repairs to Plaster   | 688             |
| 14.2              | Fixing Door, Window or Clerestory Window Chowkhat in existing opening                                    | 689             |
| 14.3              | Fixing Chowkhats in existing opening in Bricks/ RCC Wall with dash Fastners                              | 690             |
| 14.4              | Making opening in the Masonry Construction and Fixing Chowkhats for Doors, Window and Clerestory Windows | 691             |
| 14.5              | Renewing Floating Glass Panes with Putty and Nails   | 692             |
| 14.6              | Renewing Floating Glass Panes with Wooden Fillets  | 693             |
| 14.7              | Renewing Floating Glass Panes & Refixing Existing Wooden Fillets   | 693             |
| 14.8              | Providing New Wooden Fillets   | 693             |
| 14.9              | Renewal of Old Putty of Glass Panes  | 694             |
| 14.10             | Refixing Old Glass Panes with Putty and Nails.   | 694             |
| 14.11             | Fixing Old Glass Panes with Wooden Fillets.  | 694             |
| 14.12             | Fixing Fan Clamps in Existing RCC Slabs  | 694             |
| 14.13             | Regrading of Mud Phuska Terracing  | 694             |
| 14.14             | Replacing Red or White Sand Stone Slabs in Roofing   | 695             |
| 14.15             | Renewing Wooden Battens / Beams in Roofs   | 696             |
| 14.16             | Panelled Glazed or Panelled and Glazed Shutters  | 696             |
| 14.17             | Trellis (Jaffri) Work  | 700             |
| 14.18             | Fittings   | 700             |
| 14.19             | White Wash with Lime (Shifted to 13.14)  | 704             |

|       |   |     |
|-------|---|-----|
| 14.20 | Dry Distemper (Shifted to 13.18)  | 704 |
| 14.21 | Oil Emulsion (Oil Bound) Washable Distempering (Shifted to 13.19)                         | 704 |
| 14.22 | Cement Paint (Shifted to 13.21)   | 704 |
| 14.23 | Painting Readymade Mixed Paint over G.S. Sheets   | 704 |
| 14.24 | Painting Cast Iron Rain Water, Soil, Waste and Vent Pipes and Fittings (Shifted to 13.44) | 705 |
| 14.25 | Painting with Wood Preservative (Shifted to 13.45)  | 705 |
| 14.26 | Wall Painting with Plastic Emulsion Paint (Shifted to 13.46)                              | 705 |
| 14.27 | Painting with Enamel Paint  | 705 |
| 14.28 | Painting with Synthetic Enamel Paint (Shifted to 13.47)                                   | 705 |
| 14.29 | Painting with Aluminium Paint (Shifted to 13.48)  | 705 |
| 14.30 | Painting with Anti Corrosive Bitumastic Paint (Shifted to 13.35)                          | 705 |
| 14.31 | Varnishing  | 705 |
| 14.32 | Lettering with Paint (Shifted to 13.40)   | 707 |
| 14.33 | Double Scaffolding  | 707 |
| 14.34 | Fixing Old Wind Ties  | 707 |
| 14.35 | Brick work in mud mortar  | 707 |
| 14.36 | Brass curtain rods  | 708 |
| 14.37 | Fixing M.S round or square bar in wooden frame of window                                  | 709 |
| 14.38 | Providing wooden karries for roofing  | 709 |
| 14.39 | Double scaffolding system upto seven storey height made with M.S tube                     | 709 |

|           |  |     |
|-----------|--|-----|
| 14.40     | Repair to plaster in patches.  | 710 |
| 14.41.1   | Cleaning of water storage tanks  | 710 |
| 14.41.2   | Cleaning and de-silting of gully trap  | 710 |
| 14.41.3   | Cleaning of choked sewer line  | 711 |
| 14.41.4   | Cleaning of underground Sump, Over Head R.C.C. Tank  | 711 |
| 14.42     | Disconnecting damaged overhead/terrace   | 712 |
| 14.43     | Replacement of old damaged W.C. seats  | 712 |
| 14.44     | Cutting holes of required size in brick masonry wall   | 712 |
| 14.45     | Dismantling W.C. pan of all sizes  | 712 |
| 14.46     | Hacking of C.C. flooring   | 713 |
| 14.47     | Dismantling 15 to 40mm dia G.I. pipe   | 713 |
| 14.48     | Taking out existing wooden door shutter and re-fixing the same after repairs                             | 713 |
| 14.49     | Water proofing treatment with app (atactic polypropylene polymeric) membrane                             | 713 |
| 14.50     | Five layered water proofing treatment with atactic polypropylene polymer modified prefabricated membrane | 717 |
| 14.51     | Extra for covering of app modified prefabricated membrane with geotextile                                | 720 |
| 14.52     | Providing round the clock security guard without gun   | 720 |
| 14.53     | Providing round the clock security guard with gun  | 720 |
| Fig. 14.1 | Fixing of Fan Clamps in Existing R.C.C. Slabs  | 721 |
| Fig. 14.2 | Terminology Timber Door, Window & Ventilator Components  | 722 |
| Fig. 14.3 | Flush Bolts  | 723 |

|            |   |     |
|------------|---|-----|
| Fig. 14.4  | Flush Door Stopper  | 724 |
| Fig. 14.5  | Window Stay   | 725 |
| Fig. 14.6  | Typical details of Multi-Stage Shuttering                                     | 726 |
| Fig. 14.7  | Five Course Water Proofing Treatment with APP Modified Polymeric Membrane     | 727 |
| Fig. 14.8  | Grading Chajja with Cement Mortar 1:3/1:4                                     | 727 |
| Fig. 14.9  | Grading Roof Slab with Cement Concrete  | 728 |
| Fig. 14.10 | Water Proofing  | 728 |
| Fig. 14.11 | Five Layers Water-Proofing Treatment with APP Modified Prefabricated Membrane | 729 |

### LIST OF BUREAU OF INDIAN STANDARD CODES

| <i>S. No.</i> | <i>BIS. No.</i> | <i>Subject</i>                                    |
|---------------|-----------------|---|
| 1.            | IS 419          | Specifications for Putty for use in Window Frames |
| 2.            | IS 14900        | Specifications for Transparent Float Glass        |



## **14.0 REPAIRS TO BUILDINGS**

### **14.1 REPAIRS TO PLASTER**

**14.1.0** The work includes cutting the patch and preparing the wall surface. Patches of 2.50 square metres and less in area shall be measured under item of 'Repairs to Plaster' under this sub-head. Plastering in patches over 2.5 square metres in area shall be paid for at the rate as applicable to new work under sub head 'Finishing'.

#### **14.1.1 Scaffolding**

Scaffolding as required for the proper execution of the work shall be erected. If work can be done safely with the ladder or jhoola these will be permitted in place of scaffolding.

#### **14.1.2 Cutting**

The mortar of the patch, where the existing plaster has cracked, crumbled or sounds hollow when gently tapped on the surface, shall be removed. The patch shall be cut out to a square or rectangular shape at position marked on the wall as directed by the Engineer-in-Charge or his authorized representative. The edges shall be slightly under cut to provide a neat joint.

#### **14.1.3 Preparation of Surface**

The masonry joints which become exposed after removal of old plaster shall be raked out to a minimum depth of 10 mm in the case of brick work and 20 mm in the case of stone work. The raking shall be carried out uniformly with a raking tool and not with a basuli, and loose mortar dusted off. The surface shall then be thoroughly washed with water, and kept wet till plastering is commenced.

In case of concrete surfaces, the same shall be thoroughly scrubbed with wire brushes after the plaster had been cut out and pock marked as described in 13.1.2. The surface shall be washed and cleaned and kept wet till plastering is commenced.

#### **14.1.4 Application of Plaster**

Mortar of specified mix with the specified sand shall be used. The method of application shall be as described for single coat plaster work of the specified mix and under Chapter 13. The surface shall be finished even and flush and matching with the old surrounding plaster. All roundings necessary at junctions of walls, ceilings etc. shall be carried out in a tidy manner as specified in sub-head 13.0.

All dismantled mortar & rubbish etc. shall be disposed off within 24 hours from its dismantling promptly as directed by the Engineer-in-Charge.

#### **14.1.5 Protective Measure**

Doors, windows, floors, articles of furniture etc. and such other parts of the building shall be protected from being splashed upon. Splashing and droppings, if any, shall be removed by the contractor at his own cost and the surface cleaned. Damages, if any, to furniture or fittings and fixtures shall be recoverable from the contractor.

#### **14.1.6 Curing**

Curing shall be done as per plaster work with special reference to the particular type of plaster mix as described under sub-head 'finishing'.

#### **14.1.7 Finishing**

After the plaster is thoroughly cured and dried the surface shall be white washed or colour washed to suit the existing finishing as required unless specified.

#### **14.1.8 Measurements**

Length and breadth shall be measured correct to a cm. The area shall be calculated in square metre correct to two places of decimal. Patches below 0.05 square metre in area shall not be measured for payment.

Pre- measurements of the patches to be plastered shall be recorded after the old plaster has been cut and wall surface prepared.

#### **14.1.9 Rate**

The rate includes the cost of all the materials and labour involved in all the operations described above including lead as described in the item for disposal of old dismantled plaster /material.

### **14.2 FIXING DOOR, WINDOW OR CLERESTORY WINDOW CHOWKHATS IN EXISTING OPENING**

#### **14.2.1 Making Holes**

**14.2.1.1** In case of door frames without sills, holes 40 mm deep shall be made in the floor for fixing the lower end of verticals of the frames. For doors with sills, the sill plates shall be partly fixed in the floor so that they project above the floor to the height as directed by the Engineer-in-Charge.

**14.2.1.2** For embedding hold fasts of doors, windows or clerestory windows, the requisite number of holes at the correct positions shall be cut out in the masonry. The size of the holes shall be such that the chowkhats with the hold-fasts can be conveniently erected in position. Where necessary, masonry shall be chipped uniformly to facilitate easy insertion of the frame in the opening.

**14.2.1.3** Special care shall be taken when holes are made in load bearing pillars or wall portions separated by openings to ensure that beams etc. supported by them are properly propped up. In such portions cutting holes shall be done on one side at a time. The sides of the holes shall be truly parallel and perpendicular to the plane of the wall. Due care shall be taken, not to disturb the adjoining masonry and the masonry under the bearings of lintels and arches etc. spanning the opening. The holes shall then be cleaned of all dust, mortar and brick bats or stone pieces and thoroughly wetted.

#### **14.2.2 Fixing**

The sides of chowkhats of door, window or clerestory window abutting against or to be embedded in masonry shall be painted with two coats of coal tar before being placed in position. The chowkhats shall then be inserted in position with their hold-fasts bolted tight. The chowkhats shall then be adjusted to proper line and plumb and secured in position by temporary bracing which shall not be disturbed or removed until the hold fasts are embedded in the masonry and the concrete block has set. The concrete to be used for embedding hold- fasts shall be cement concrete 1:3:6 mix (1 cement : 3 coarse sand : 6 graded stone aggregate 20 mm nominal size).

The minimum size of concrete block in which the hold-fasts will be embedded shall be 30 x 10 x 15 cm for 35 cm long holdfasts. The concrete of the block shall completely fill the hole made in the masonry for the purpose. The chase cut in the floor shall be cut square and construction joint shall be provided filled in with cement concrete 1:2:4 (1 cement : 2 coarse sand : 4 graded stone aggregate 20 mm nominal size) and rendered smooth at the top and finished to match the existing type of floor.

#### **14.2.3 Finishing**

After the surface surrounding the hold-fasts has sufficiently dried it shall be cleaned of dust etc. and wetted. It shall then be plastered with cement mortar 1:4 (1 cement : 4 fine sand) flush and matching with the surrounding plaster work. In case of exposed brick work, stone work, the finishing shall be done to match the surrounding. Any other portion of the wall opening, if damaged, shall be repaired in similar way.

After the cement plaster patches have been thoroughly cured and dried, they shall either be white washed or colour washed as required unless otherwise specified. All malba and debris obtained from cutting etc. shall be disposed off to the nearest dumping ground promptly as directed by Engineer-in-Charge.

#### **14.2.4 Measurements**

The chowkhats of doors, window and clerestory windows shall be enumerated separately.

#### **14.2.5 Rate**

The rate shall apply irrespective of the size of the chowkhat upto a maximum area of opening 3.75 square metres for doors, 2.5 square metres for windows and 1.2 square metres for clerestory windows. The rate is inclusive of labour and materials involved in all the operations described above, excluding (a) cost of chowkhats and (b) cost of supplying and fixing the hold-fasts including C.C. block and bolts.

### **14.3 FIXING CHOWKHATS IN EXISTING OPENING IN BRICKS / RCC WALL WITH DASH FASTNERS**

**14.3.1** In case of door frames without sills, holes 40 mm deep shall be made in the floor for fixing the lower end of verticals of the frames. For doors with sills, the sill plates shall be partly fixed in the floor so that they project above the floor to the height as directed by the Engineer-in-Charge.

**14.3.1.1** For fixing dash fasteners /chemical fasteners of doors, windows or clerestory windows, the requisite number of holes at the correct positions shall be in the masonry/RCC wall. The size of holes shall be such that the fasteners can be conveniently placed in position. Where necessary, masonry shall be chipped uniformly to facilitate easy insertion of the frame in the opening.

**14.3.1.2** Special care shall be taken when holes are made in load bearing pillars or wall portions separated by openings to ensure that beams etc. supported by them are properly propped up. In such portions cutting holes shall be done on one side at a time. The sides of the holes shall be truly parallel and perpendicular to the plane of the wall. Due care shall be taken, not to disturb the adjoining masonry and the masonry under the bearings of the lintels and arches etc. spanning the opening. The holes shall then be cleaned of all dust, mortar and brick bats or stone pieces and thoroughly wetted.

#### **14.3.2 Fixing**

The sides of chowkhats of door, window or clerestory window abutting against or to be embedded in masonry shall be painted with two coats of coal tar before being placed in position. The chowkhats shall then be inserted in position tight. The chowkhats shall then be adjusted to proper line and plumb and secured in position by temporary bracing which shall not be disturbed or removed until the fasteners are embedded in the masonry /RCC wall.

#### **14.3.3 Finishing**

After the surface surrounding the hold-fasts has sufficiently dried it shall be cleaned of dust etc. and wetted. It shall then be plastered with cement mortar 1:4 (1 cement: 4 fine sand) flush and matching with the surrounding plaster work. In case of exposed brick work, stone work, the finishing shall be done to match the surrounding. Any other portion of the wall opening, if damaged, shall be repaired in similar way.

After the cement plaster patches have been thoroughly cured and have dried, they shall either be white washed or colour washed as required unless otherwise specified. All malba and debris obtained from cutting etc. shall be disposed off to the nearest dumping ground.

#### **14.3.4 Measurements**

The chowkhats of doors, window and clerestory windows shall be enumerated separately.

#### **14.3.5 Rate**

The rate shall apply irrespective of the size of the chowkhat upto a maximum area of opening 3.75 square metres for doors, 2.5 square metres for windows and 1.2 square metres for clerestory windows. The rate is inclusive of labour and materials involved in all the operations described above, including cost of dash fasteners chemical fasteners but excluding cost of chowkhat.

### **14.4 MAKING OPENING IN THE MASONRY CONSTRUCTION AND FIXING CHOWKHATS FOR DOORS, WINDOWS AND CLERESTORY WINDOWS**

**14.4.0** Before making opening it is necessary to examine that the wall exclusive of opening is adequate to take the load coming on the structure. All the structural members supported on the walls which have direct bearing over the area in which opening is to be made, shall be properly supported with props to relieve the load from masonry wall till the lintel over the opening is strong enough to take the load. Care should also be taken not to disturb the adjoining masonry.

All precautions as explained in Chapter 15.0 (Demolition and Dismantling) should be followed in case of dismantling the external walls. The portion to be dismantled may be clearly marked on both sides of the wall. Dismantling shall be carried out from top to bottom within the marked area. The sides of the opening shall be as far as possible, parallel and perpendicular to the plane of wall.

#### **14.4.1 Making Opening**

**14.4.1.1** The openings for fixing door/window frames shall be to the extent of accommodating the hold fast. The hold fasts shall be fixed in cement concrete 1:3:6 (1 cement : 3 coarse sand : 6 stone aggregate 20 mm nominal size) or in masonry as required. Where only opening is to be made in the masonry, the width of the opening shall be such that the sides of the masonry can be built true to line and plumb and such masonry built shall conform to the specifications of the particular type of masonry in which the opening is made with particular reference to size of corner stones etc. In order to get continuity with old masonry, proper key shall be provided. The height of the opening shall be such that it can accommodate the required depth of the RCC lintel also.

**14.4.1.2** The sides of opening in masonry shall be cleaned of all dust, mortar, brick bats/loose stones, chips etc. and the surface left rough and thoroughly wetted.

**14.4.1.3** The lintel shall be invariably cast first in the opening made for the purpose. One side of the shuttering shall be kept open in the beginning till the concrete is laid. The shuttering shall then be fixed for half of the opening and concreting completed.

**14.4.1.4** Curing of lintel casted shall be done for a minimum period of 7 days.

**14.4.1.5** Precast RCC lintel or R.S. Joist may also be used if directed by the Engineer-in-Charge.

#### **14.4.2 Fixing Chowkhats**

Fixing of chowkhats shall be done as specified in 14.2.2.

#### **14.4.3 Finishing**

**14.4.3.1** After the surface of the sides of masonry opening and lintel are sufficiently dry and set, it shall be cleaned free of dust, loose mortar etc. and wetted thoroughly. It shall then be plastered or pointed as required flush with the surrounding masonry work. Any other portion of the wall if damaged shall be finished in similar manner.

**14.4.3.2** After the cement plaster/pointing has been thoroughly cured and have dried the surface shall be either white or colour washed/painted as required. The surface of the wall which is spoiled due to splashing of mortar shall be cleaned forthwith.

#### 14.4.4 Measurements

The openings made for doors, windows, clerestory windows shall be measured correct to cms and area shall be calculated in square metres correct to two places of decimal.

#### 14.4.5 Rate

The rate shall apply per sqm of opening. The rate is inclusive of labour and material involved in all the operations described above.

Cost of Chowkhats, cost of CC blocks, cost of supplying the hold-fasts bolts, cost of R.C.C lintel or R.S. Joist which shall be paid for separately.

### 14.5 RENEWING FLOATING GLASS PANES WITH PUTTY AND NAILS

#### 14.5.1 Removing Broken Glass Panes

Old putty shall be raked out with hack knife. The brad (small nails without head) and pieces of broken glass shall be removed from the rebates of the sash bars. The pieces of glass panes as found useful shall be handed over to the Engineer-in-Charge of the work. No glass shall be inserted in frames until they have been primed and prepared for painting so that the wood may not draw oil out of the putty.

#### 14.5.2 Floating Glass Panes

The floating glass panes shall conform to specifications described in IS 14900.

#### 14.5.3 Fixing

The floating glass panes shall be so cut that it fits slightly loose in the frame and as specified in A&B of IS 14900. A thin layer of Putty conforming to IS 419 shall be prepared by mixing one part of white lead with three parts of finely powdered chalk and then adding the boiled linseed oil to the mixture to form a stiff paste and adding varnish to the paste @ 1 litre of varnish to 18 kg. of paste. The putty so prepared in the form of a stiff paste shall be drawn along the inner edge of the rebate, for bedding the back of the glass panes. The glass pane shall then be put in position, pressed home against the thin layer of the putty, and secured in rebate by new brads. The brads shall not be spaced more than 7.5 cm from each corner and not more than 15 cm apart. The putty shall then be applied in the rebate uniformly, sloping from the inner edge of the rebate. In doing this care shall be taken to keep the putty a little within the inner edge of the rebate and surplus putty removed so that none of it is seen through the glass from the inside. The putty so filled in the rebates shall be levelled smooth and finished in a straight line. When dried the putty shall be covered with a coat of paint of approved quality and shade to match the existing finish of joinery work.

The floating glass panes shall be cleaned with methylated spirit. All splashings or droppings of washing and paints shall be removed. All rubbish and unserviceable materials shall be disposed off to the dumping ground promptly as per the direction of Engineer-in-Charge.

#### Thickness and Tolerance of Floating Glass

| <i>Thickness</i> | <i>Tolerance</i> |
|------------------|------------------|
| 4 mm             | ± 0.3 mm         |
| 5 mm             | ± 0.3 mm         |
| 6 mm             | ± 0.3 mm         |

**Note :** Frosted glass panes should be replaced with frosted glass panes. These shall be fixed with frosted face on the inside.

#### 14.5.4 Measurements

Length and breadth of glass panes shall be measured correct to a cm. The area of the glass panes as fixed shall be calculated in square metre correct to two places of decimal.

#### **14.5.5 Rate**

The rate shall include the cost of labour and materials involved in all the operations described above.

### **14.6 RENEWING FLOATING GLASS PANES WITH WOODEN FILLETS**

#### **14.6.1 Removing Broken Glass Panes**

The specifications shall be the same as in para 14.5.1 except that the wooden fillets including nails shall be taken out carefully.

#### **14.6.2 Glazing**

The specifications for glass panes and their fixing shall be the same as per IS 14900. The fillet shall either be fixed flush or projected uniformly to match with the existing work by means of nails (brads).

The new fillet provided shall be painted or finished otherwise to match with the existing finish of the joinery work.

The glass panes shall be cleaned with methylated spirit of all sorts of splashing and droppings of wash and paints.

All rubbish and unserviceable materials shall be disposed off in the dumping ground promptly as per the direction of Engineer-in-Charge.

#### **14.6.3 Measurements**

Length and breadth of glass panes shall be measured correct to a cm. The area of the glass panes as fixed shall be calculated in square metre correct to two places of decimal. The new wooden fillets fixed shall be measured in running metres correct to a cm.

#### **14.6.4 Rate**

The rates shall include the cost of labour and material involved in all the operations described above except that the cost of new wooden fillets used in the work and their finishing shall be paid for separately.

**14.7 RENEWING FLOATING GLASS PANES AND REFIXING EXISTING WOODEN FILLETS** The specifications shall be same as described in 14.6 above.

### **14.8 PROVIDING NEW WOODEN FILLETS**

**14.8.1** The fillets shall be of wood, as specified in the item of work, these shall be cut and planed smooth to the required shape and dimensions.

#### **14.8.2 Fixing**

The specifications for glass panes and their fixing shall be the same as given in 9.6.4.6. The fillet shall either be fixed flush or projected uniformly to match the existing work.

The fillet shall be painted or finished otherwise to match with the existing finish of the joinery work.

The glass panes shall be cleaned with methylated spirit of all sorts of splashing and dropping of wash and paints.

#### **14.8.3 Measurements**

The fillets shall be measured in running metres. The lengths shall be measured correct to a cm.

#### **14.8.4 Rate**

The rate shall include the cost of all labour and materials involved in all the operations described above. The rate shall also include the cost of removal of worn out fillets, when these are met with in old work. The rate shall vary according to the class of wood used.

## **14.9 RENEWAL OF OLD PUTTY OF GLASS PANES**

**14.9.1** The old putty shall be removed as specified in 14.5.1 and new putty fixed as specified in 14.5.3.

### **14.9.2 Measurements**

The work shall be measured in running metres. The length along the rebate shall be measured correct to a cm.

### **14.9.3 Rate**

The rate shall include the cost of labour and materials involved in all the operations described above.

## **14.10 REFIXING OLD GLASS PANES WITH PUTTY AND NAILS**

**14.10.1** Specification same as described in 14.5 above. Except for the glass panes, old glass panes will be used for which nothing extra will be paid.

## **14.11 FIXING OLD GLASS PANES WITH WOODEN FILLETS**

**14.11.1** Specifications same as described in para no. 14.6 above except for the glass panes. Old glass panes will be used for which nothing extra shall be paid.

## **14.12 FIXING FAN CLAMPS IN EXISTING R.C.C. SLABS**

**14.12.1** The fan clamps to be fixed in an existing R.C.C. slab shall be of type shown in Fig. 14.1. These shall be made of 16 mm dia M.S. bar.

### **14.12.2 Fixing**

A 15 x 7.5 cm size chase shall be cut from the ceiling to expose the reinforcement and upto 2.5 cm clear round the reinforcement bar as directed. This shall be done without any damage to adjoining portion of the ceiling.

The two arms at the ends of the clamps shall be passed through the space over the reinforcement bar from the bottom of the slab. Then the two arms shall be bent down about 1.5 cm by means of a crow bar. The clamp shall be held in position and chase in the ceiling filled with cement concrete 1:2:4 (1 cement : 2 coarse sand : 4 graded stone aggregate 20 mm nominal size). The ceiling shall then be finished to match the existing surface and properly cured.

The exposed portion of the clamp shall be given two or more coats of paint including one priming coat of shade as directed by the Engineer-in-Charge.

### **14.12.3 Measurements and Rate**

Clamps shall be counted in numbers. The rate per fan clamp shall include the cost of labour and materials involved in all the operations described above. The rate shall apply irrespective of the thickness of the slab.

## **14.13 REGRADING OF MUD PHUSKA TERRACING**

### **14.13.1 Dismantling**

The specified area of roof as directed by the Engineer-in-Charge shall be dismantled carefully so that the minimum of tiles or bricks are damaged. The serviceable tiles or bricks shall be cleaned and stacked on places as directed by the Engineer-in-Charge, or on the parapet wall if convenient and safe or otherwise carried to ground and stacked as directed by the Engineer-in-Charge for which nothing extra shall be paid.

All unserviceable tiles and debris shall be disposed off to the dumping ground as directed by the Engineer-in-Charge. Suitable earth shall be stacked separately for reuse.



#### **14.13.2 Laying**

Mud phuska shall be removed, cleaned of all foreign matter and brought to the ground. After approval of the Engineer-in-Charge it shall then be reduced to fine powder and then mixed with additional soil for regrading and additional fibrous reinforcing materials such as chopped straw or fresh bhusa at the rate of 8 kg/cum of mud mortar shall be mixed with old earth. The choppings used shall not be more than 20 mm in length. A pit shall be dug where the mixture shall be added and allowed to mature for a period of not less than 7 days. During this period the mixture shall be worked up at interval with feet and spades so as to get pugged into homogeneous mass free from lumps and clods. The consistency of the mortar shall be adjusted by taking it in a trowel and observing how it slides off the face of the trowel. The mortar shall readily slide off, but at the same time shall be so wet as to part into large drops before falling.

#### **14.13.3 Leeping Plaster**

Shall be prepared by mixing soil which is free from coarse sand with approximately equal volume of cow dung and adding the required quantity of water. The mixture shall work to a homogeneous mass. The quantity of gobar used in gobri leeping shall not be less than 0.03 cum per 100 sqm of plaster area.

#### **14.13.4 Laying Tile Bricks and Grouting**

The specifications shall be as described in 12.11.4 except that new tile as necessary to replace the broken tiles shall be used. Half or cut brick tiles shall not be used except where necessary to complete the bond. New work shall be finished in level with surrounding surface.

#### **14.13.5 Curing and Measurements**

Shall be as specified in 12.11.5 and 12.11.6.

#### **14.13.6 Rate**

The rate shall include the cost of all materials and labour involved in all the operations described above except for new tiles or bricks which shall be paid for separately.

### **14.14 REPLACING RED OR WHITE SAND STONE SLABS IN ROOFING**

#### **14.14.1 Dismantling Roof**

The general specifications given in 15.1 shall apply. The cracked or decayed stone slabs as marked by the representative of the Engineer-in-Charge shall be removed after dismantling the tile covering with mud phuska over it if any, or other type of covering over the stone slabs.

Mud phuska terracing with tile brick covering shall be dismantled as per 14.13.1 over the specified cracked or decayed tiles to an area extending 15 cm on all sides of stone slabs. This area may be increased by the Engineer-in-Charge, if found necessary. Stone slabs shall then be dismantled and carried down and stacked properly.

In case the stone slabs are not covered at top with mud phuska or lime terracing, the decayed or cracked stone slabs shall be dismantled and carried down or lowered with ropes and stacked properly.

#### **14.14.2 Relaying of Stone Slab Roofing**

Before placing the stone slab the condition of the existing wooden battens shall be checked by suitable methods and replaced if required by Engineer-in-Charge. The upper surface of the wooden battens and beams supporting the stone slab, shall be painted with two coats of coal tar if not already treated and with one coat of coal tar if originally treated.

The specifications for stone slabs, laying, finishing and curing, shall be as described under 12.15.

#### **14.14.3 Relaying of Mud Phuska with Tile**

The specifications shall be as described in 14.13.2 to 14.13.4 and shall be paid for separately.

#### **14.14.4 Curing and Measurements**

Shall be done as described in 12.11.5 and 12.11.6.

**14.14.5** All unserviceable material shall be disposed off to the dumping ground as directed by the Engineer-in-Charge.

#### **14.14.6 Rate**

The rate shall include the cost of materials and labour involved in all the operations described above, except the cost of wooden battens which shall be paid for separately.

### **14.15 RENEWING WOODEN BATTENS /BEAMS IN ROOFS**

#### **14.15.1 Dismantling Wooden Battens / Beams**

Dismantling shall be done as described in para 15.1 of dismantling and demolishing. Proper scaffolding shall be erected and got inspected by Engineer-in -Charge. Propping and bracing as directed should be done adequately and members required to be dismantled should be removed carefully including nails/bolts etc. and dismantling of masonry wall. The dismantled members should not be thrown or dropped but lowered with ropes carefully and stacked properly.

#### **14.15.2 Relaying of Wooden Battens**

The wooden battens/beams of required section and size should be placed at proper interval and surface of the wooden batten/beams shall be painted with oil type wood preservative of approved brand and manufacture and as per the direction of Engineer-in-Charge.

**14.15.3** All serviceable material shall be stacked properly and all the unserviceable material shall be deposited with the Engineer-in-Charge.

#### **14.15.4 Measurement**

The work shall be measured in cubic meters. The length, breadth and depth shall be measured correct to a cm.

#### **14.15.5 Rate**

The rate shall include the cost of materials and labour involved in the operations described above.

### **14.16 PANELLED GLAZED OR PANELLED AND GLAZED SHUTTERS**

**14.16.0** Pannelled or glazed shutters for doors, windows, ventilators and cupboards shall be constructed in the form of timber frame work of stiles and rails with panel inserts of timber, plywood, block board, veneered particle board, fibre board wire gauze or sheet glass. The shutters may be single or multipanelled, as shown in the drawings or as directed by the Engineer-in-Charge. Timber for frame work, material for panel inserts and thickness of shutters shall be as specified. All members of the shutters shall be straight without any warp or bow and shall have smooth well planed face at right angles to each other.

Any warp or bow shall not exceed 1.5 mm. The right angle for the shutter shall be checked by measuring the diagonals and the difference between the two diagonals should not be more than  $\pm 3$  mm.

#### **14.16.1 Frame Work**

**14.16.1.1** Timber for stiles and rails shall be of the same species and shall be sawn in the directions of grains. Sawing shall be truly straight and square. The timber shall be planed smooth and accurate to the required dimensions. The stiles and rails shall be joined to each other by plain or haunched mortise and tenon joints and the rails shall be inserted 25 mm short of the width of the stiles. The bottom rails shall have double tenon joints and for other rails single tenon joints shall be provided. The lock rails of door shutter shall have its centre line at a height of 800 mm from the bottom of the shutters unless otherwise specified. The thickness of each tenon shall be approximately one- third the finished thickness of the members and the width of each tenon shall not exceed three times its thickness.

**14.16.1.2 Gluing of Joints :** The contact surfaces of tenon and mortise shall be treated, before putting together, with bulk type synthetic resin adhesive conforming to IS 851 suitable for construction in wood or synthetic resin adhesive (Phenolic and aminoplastic) conforming to IS 848 or polyvinyl acetate dispersion based adhesive conforming to IS 4835 and pinned with 10 mm dia hardwood dowels or bamboopins or star shaped metal pins; after the frames are put together and pressed in position by means of press.

**14.16.1.3** Stiles and bottom rail shall be made out of one piece of timber only. Intermediate rail exceeding 200 mm in width may be out of one or more pieces of timber. The width of each piece shall be not less than 75 mm. Where more than one piece of timber is used for rails, they shall be joined with a continuous tongued and grooved joint glued together and reinforced with metal dowels at regular intervals not exceeding 200 mm.

**TABLE 14.1**  
**Dimensions of Components of Frame Work**

| Sl. No.  | Description                | Width | Thickness    |
|--|----------------------------|-------|--------------|
|  |                            | Mm    | mm           |
| <b>A. DOOR SHUTTERS</b>                              |                            |       |              |
| (a)  | Stile, top and freeze rail | 100   | 35 or 40     |
| (b)  | Lock rail                  | 150   | 35 or 40     |
| (c)  | Bottom rail                | 200   | 35 or 40     |
| (d)  | Muntin                     | 100   | 35 or 40     |
| (e)  | Glazing bar                | 40    | 35 or 40     |
| <b>B. WINDOW, VENTILATOR &amp; CUPBOARD SHUTTERS</b> |                            |       |              |
| (a)  | Stile, top and freeze rail | 80    | 20, 25 or 30 |
| (b)  | Bottom rail                | 80    | 20, 25 or 30 |
| (c)  | Muntin                     | 60    | 20, 25 or 30 |
| (d)  | Glazing bar                | 40    | 20, 25 or 30 |

**14.16.2** Muntin and glazing bars where required shall be stubtenoned to the maximum depth which the size of the member would permit or to a depth of 25 mm whichever is less. Unless otherwise specified the finished dimensions of the components of frame work of shutters shall be as given in Table 14.1. The tolerance on width of styles and rail shall be  $\pm 3$  mm. The tolerance in thickness will be  $\pm 1$  mm. The thickness of all components of frame work shall be the same as the thickness of the shutter. Tolerance on over all dimensions of the shutter shall be  $\pm 3$  mm.

#### **14.16.3 Rebating**

The shutters shall be single-leaf or double leaved as shown in the drawings or as directed by the Engineer-in-Charge. In case of double leaved shutters, the meeting of the stiles shall be rebated by one-third the thickness of the shutter. The rebating shall be either splayed or square type as shown in Fig. 14.2.

#### **14.16.4 Panelling**

The panel inserts shall be either framed into the grooves or housed in the rebate of stiles and rails. Timber, plywood, hard board and particle board panels shall be fixed only with grooves. The depth of the groove shall be 12 mm and its width shall accommodate the panel inserts such that the faces are closely fitted to the sides of the groove. Panel inserts shall be framed into the grooves of stiles and rails

to the full depth of the groove leaving on space of 1.5 mm. Width and depth of the rebate shall be equal to half the thickness of stiles and rails. Glass panels, asbestos panels wire gauze panels and panel inserts of cupboard shutters shall be housed in the rebates of stiles and rails.

**14.16.4.1 Timber Panels :** Timber panels shall be preferably made of timber of large width; the minimum width and thickness of the panel shall be 150 mm, and 15 mm respectively. When made from more than one piece, the pieces shall be jointed with a continuous tongued and grooved joint glued together and reinforced with headless nails at regular intervals not exceeding 100 mm. Depth and thickness of such joint shall be equal to one- third of thickness of panel. The panels shall be designed such that no single panel exceeds 0.5 square metre in area. The grains of timber panels shall run along the longer dimensions of the panels. All panels shall be of the same species of timber unless otherwise specified.

**14.16.4.2 Plywood Panels :** Plywood boards used for panelling of shutters shall be BWP type or grade as specified in 9.2.2. Each panels shall be a single piece of thickness, 9 mm for two or more panel construction and 12 mm for single panel construction unless otherwise specified.

**14.16.4.3 Block Board Panels :** Block board used for panelling of shutters shall be Grade I (Exterior Grade) bonded with BWP Type Synthetic resin adhesives as specified in 9.2.2. Each panel shall be a single piece of thickness 12 mm unless otherwise specified.

**14.16.4.4 Veneered Particle Board Panels :** Veneered Particle board used for panelling of shutters shall be Exterior Grade bonded with BWP type synthetic resin adhesive as specified in 9.2.4.2. Each panel shall be a single piece of thickness 12 mm unless otherwise specified.

**14.16.4.5 Fibre Board Panels :** Fibre board used for panelling of shutters shall be Exterior Grade bonded with BWP type synthetic resin adhesive as specified in 9.2.8.2. Each fibre board panel shall be a single piece of thickness 10 mm unless otherwise specified.

**14.16.4.6 Wire Gauze Panels :** Wire Gauze used for panelling of shutters shall be woven with 0.63 mm dia galvanised mild steel wire to form average aperture size of 1.40 mm as specified in 9.2.10. Wire gauze shall be securely housed into the rebates of stiles and rails by giving right angles bend turned back and fixed by means of suitable staples at intervals of 75 mm and over this wooden beading shall be fixed. The space between the rebate and the beading shall be fixed with putty to give a neat finish. Each wire gauze panel shall be a single piece, and the panels shall be so designed that no single panels exceeds 0.5 sqm in area. However, care shall be taken to prevent sagging of wire gauge, of panel by providing and fixing 20 x 20 mm square or equivalent beading to the external face in the required patterns as decided by the Engineer-in-Charge.

**14.16.4.7 Glass Panels :** Glass panelling (Glazing) shall be done with float sheet glass as per IS 14900. Glazing in the shutters of doors, windows and ventilators of bath, WC and Lavatories shall be provided with frosted glass the weight of which shall be not less than 10 kg/sqm. Frosted glass panes shall be fixed with frosted face on the inside. Glass panels shall be fixed by providing a thin layer of putty conforming to IS 419 applied between glass pane and all along the length of the rebate and also between glass panes and wooden beading.

**14.16.4.8 Putty** can be prepared by mixing one part of white lead with three parts of finely powdered chalk and then adding boiled linseed oil to the mixture to form a stiff paste and adding varnish to the paste at the rate of 1 litre of varnish to 18 kg of paste. Fixing of glass panes without beading shall not be permitted. Glazing shall be done after the shutters have been primed and prepared for painting, so that wood may not draw oil out of putty.

**14.16.4.9 Finish :** Panels of shutters shall be flat and well sanded to a smooth and level surface.

#### **14.16.5 Beading**

Beadings in panelled shutter shall be provided where specified in architectural drawings or directed by the Engineer-in -Charge. Each length of beading shall be single piece. Joints at the corners shall be mitred and exposed edges shall be rounded. Beading shall be fixed with headless nails at 75 mm intervals. For external shutters, the beading shall be fixed on the outside face.

#### **14.16.6 Machine/Factory made Shutters**

Machine made shutters, where specified, shall be procured from an approved factory. For machine made shutters, operations like sawing, planning, making tongue and tenons, cutting grooves, mortises and rebates, drilling holes and pressing of joints shall be done by suitable machines. Machines made shutters shall be brought to the site fully assembled but without any priming coat. Panel inserts of sheet glass and wire gauze may, however, be fixed at site.

#### **14.16.7 Fixing of Shutters**

For side hung shutters of height upto 1.2 m, each leaf shall be hung on two hinges at quarter points and for shutter of height more than 1.2 m, each leaf shall be hung on three hinges one at the centre and the other two at 200 mm from the top and bottom of the shutters. Top hung and bottom hung shutters shall be hung on two hinges fixed at quarter points of top rail or bottom rail. Centre hung shutter shall be suspended on a suitable pivot in the centre of the frame. Size and type of hinges and pivots be as specified. Flap of hinges shall be neatly counter sunk into the recesses cut to the exact dimensions of flap. Screws for fixing the hinges shall be screwed in with screw driver and not hammered in. Unless otherwise specified, shutters of height more than 1.2 m shall be hung on butt hinges of size 100 mm and for all other shutters of lesser height butt hinges of size 75 mm shall be used. For shutter of more than 40 mm thickness butt hinges of size 125 × 90 × 4 mm shall be used. Continuous (piano) hinges shall be used for fixing cup-board shutters where specified.

#### **14.16.8 Fittings**

Fittings shall be provided as per schedule of fittings decided by Engineer-in- Charge. Appendix H (P-361/SH 9.0) gives for guidance the schedule of fittings and screws usually provided. Cost of providing and fixing shutter shall include cost of hinges and necessary screws for fixing the same. All other fittings shall be paid for separately. The fittings shall conform to specifications laid down in 9.6.8. Where the fittings are stipulated to be supplied by the department free of cost, screws for fixing these fittings shall be provided by contractor and nothing extra shall be paid for the same.

#### **14.16.9 Wooden Cleats and Blocks**

Wooden cleats and blocks shall be fixed to doors and windows as directed by Engineer-in-Charge, as per size and shape approved by him. These are included in the cost of providing and fixing the shutters.

#### **14.16.10 Measurements**

Framework and panelling shall be measured separately.

**14.16.10.1 Frame Work of Shutters :** The overall length and width of the framework of the shutters shall be measured nearest to a cm in fixed position (overlaps not to be measured in case of double leaved shutters) and the area calculated in square metres correct to two places of decimeter. No deduction shall be made to form panel openings or louvers. No extra payments shall be made for shape, joints and labour involved in all operations described above.

**14.16.10.2.** For panelling of each type or for glazed panel length and width of opening for panels inserts or glazed panels shall be measured correct to a cm before fixing the beading and the area shall be calculated to the nearest 0.01 sq.m. The portions of the panel inserts or glazed panel inside the grooves or rebates shall not be measured for payment.

#### **14.16.11 Rate**

Rate includes the cost of materials and labour involved in all the operations described above. The frame work and panelling of each type or glazed panels shall be paid separately. The rate for frame work includes the cost of butt hinges and necessary screws as specified in 9.6.7. However, extra shall be paid for providing moulded beading where specified. Nothing extra shall be paid for plain beading as stated in 9.6.5 when specified in drawing.

## 14.17 TRELLIS (JAFFRI) WORK

**14.17.0** Specified timber shall be sawn in the direction of the grains. Sawing shall be truly straight and square. The timber shall be planed smooth and accurate to the full dimensions, rebates, roundings, and mouldings as shown in the drawings made, before assembly. Patching or plugging of any kind shall not be permitted except as provided.

### 14.17.1 Plain Trellis (Jaffri)

This shall consist of wooden strips or laths 35 x 10 mm section unless otherwise specified planed and nailed together at every alternate crossing. The strips shall cross each other at right angle and shall be spaced 35 mm apart, so as to form 35 x 35 mm square opening or as shown in the drawing. These shall be fixed with nails to the frame. To cover the ends of strips, 50 x 12 mm beading shall be fixed to the frame with screws. The finished work with a tolerance of  $\pm 1$  mm may be accepted.

### 14.17.2 Trellis (Jaffri) Doors and Windows Shutters

Shutter frame of specified timber shall consist of two stiles and top, lock and bottom rails, each of section 75 x 35 mm unless otherwise specified. The stiles and rails shall be properly mortised and tenoned. The tenons shall pass through the stiles for at least 3/4th of the width of the stile. Shutter frame shall be assembled and passed by the Engineer-in-Charge before jointing. The joints shall be pressed and secured by bamboo pins of about 6 mm diameter. To this frame, plain trellis (Jaffri) work as described in 9.11.1 shall be fixed as shown in the drawings or as directed by the Engineer-in-Charge. Fixing, fittings, wooden cleats and blocks shall be provided as specified under 9.6.

### 14.17.3 Measurements

Width and height of plain trellis work and trellis shutters shall be measured overall correct to a cm. The area shall be calculated in square metres nearest to two places of decimal. In case of shutters, the measurement shall be as specified in 9.11.2.

### 14.17.4 Rate

It includes the cost of materials and labour required in all the operations described above.

## 14.18 FITTINGS

**14.18.0** Fitting shall be of mild steel brass, aluminium or as specified. Some mild steel fittings may have components of cast iron. These shall be well made, reasonably smooth, and free from sharp edges and corners, flaws and other defects. Screw holes shall be counter sunk to suit the head of specified wood screws. These shall be of the following types according to the material used.

(a) *Mild Steel Fittings*

These shall be bright satin finish black stone enamelled or copper oxidised (black finish), nickel chromium plated or as specified.

(b) *Brass Fittings*

These shall be finished bright satin finish or nickel chromium plated or copper oxidised or as specified.

(c) *Aluminium Fittings*

These shall be anodised to natural matt finish or dyed anodic coating not less than grade AC 10 of IS 1868.

The fittings generally used for different type of doors and windows are indicated in Appendix H (P-361/SH 9.0) attached. The fittings to be actually provided in a particular work shall, however, be decided by the Engineer-in-Charge.



Screws used for fittings shall be of the same metal, and finish as the fittings. However, chromium plated brass screws or stainless steel screws shall be used for fixing aluminium fittings. These shall be of the size as indicated in respective figures.

Fittings shall be fixed in proper position as shown in the drawings or as directed by the Engineer-in-Charge. These shall be truly vertical or horizontal as the case may be. Screws shall be driven home with screw driver and not hammered in. Recesses shall be cut to the exact size and depth for the counter sinking of hinges.

**14.18.1 Butt Hinges**

(a) Cast brass butt hinges light/ordinary or heavy.

**14.18.1.1 Cast Brass Butt Hinges :** These shall be light/ordinary or heavy as specified. These shall be well made and shall be free from flaws and defects of all kinds. These shall be finished bright or chromium plated or oxidised or as specified. These shall generally conform to IS 205.

**Hinge Pin :** Hinge pin shall be made of brass or of phosphor bronze. The hinge pins shall be firmly rivetted and shall be properly finished. The movement of the hinge pin shall be free, easy and square and shall not have any play or shake.

**Knuckles :** The number of knuckles in each hinge shall not be less than five. The number of knuckles in case of sizes less than 40 mm shall be three. The sides of the knuckles shall be straight and at right angle to the flap. The movement of the hinge pin shall be free and easy and working shall not have any play or shake.

**Screw Holes :** The screw holes shall be clean and counter sunk and of the specified size for different types and size of hinges. The size of the holes shall be such that when it is counter sunk it shall be able to accommodate the full depth of counter sunk head of wood screw specified.

**14.18.1.2 Sampling and Criteria for Conformity :** The number of butt hinges to be selected from a lot shall depend on the size of lot and shall be in accordance with Table 10. Butt hinges for testing shall be taken at random from at least 10 per cent of the package subject to a minimum of three, equal number of hinges being selected from each package. All butt hinges selected from the lot shall be checked for dimensional and tolerance requirements. Defects in manufacture and finish shall also be checked. A lot shall be considered conforming to the requirements of this specification if the number of defective hinges among those tested does not exceed the corresponding number given in Table 14.2.

**TABLE 14.2**

| <i>Lot size</i> | <i>Sample size</i> | <i>Permissible No. of defective hinges</i> |
|-----------------|--------------------|--|
| Upto 200        | 15                 | 0  |
| 201 to 300      | 20                 | 1  |
| 301 to 500      | 30                 | 2  |
| 501 to 800      | 40                 | 2  |
| 801 and above   | 55                 | 3  |

**Note:** Any hinge which fails to satisfy the requirements of any one or more of the characteristics shall be considered as defective hinge.

**14.18.2 Spring Hinges :** (Single or double acting)

**14.18.2.1** These shall be single acting when the shutter is to open on one side only or double acting when the shutter opens on both sides. These shall be made of M.S. or brass as specified, and shall generally conform to IS 453.

Hinges shall work smoothly and shall hold the door shutter truly vertical in closed position. Each double-acting spring hinge shall withstand the following tests which shall be carried out after fixing it to a swing door in the normal manner.

- (a) When the door is pushed through 90° and released 2000 times on each side in quick succession the hinge shall show no sign of damage or any appreciable deterioration of the components during or on completion of the test.
- (b) The door shall require a force of  $2.0 \pm 0.5$  kg for 100 mm hinges and  $3.0 \pm 0.5$  kg for 125 mm and 150 mm hinges at a distance of 4.5 cm from the hinge pin to move the door through 90°.

The size of spring hinge shall be taken as the length of the plate.

**14.18.2.2** These shall be of the following type :

- (a) *Mild Steel* : The cylindrical casing shall be made either from M.S. sheet of 1.60 mm thickness, lap jointed and brazed, welded and rivetted, or from solid drawn tube of thickness, pressed to from the two casing. It shall be stove enamelled black or copper oxidized or as specified.
- (b) *Cast Brass* : The cylindrical casing shall be made either from brass sheet of 1.60 mm thickness, lap jointed and brazed, or from solid drawn brass tube of not less than 1.60 mm thickness. It shall be satin, bright nickle — plated or copper oxidized or as specified.

**14.18.2.3 Sampling** : The number of spring hinges shall be selected from the lot and this number shall depend on the size of the lot and shall be in accordance with Table 14.3.

**TABLE 14.3**

| <i>Lot size</i> | <i>Sample size</i> | <i>Permissible No. of defective spring hinges</i> |
|-----------------|--------------------|---|
| 1 to 25         | 3                  | 0   |
| 26 to 50        | 6                  | 0   |
| 51 to 100       | 12                 | 0   |
| 101 to 200      | 15                 | 0   |
| 201 to 300      | 20                 | 1   |
| 301 to 500      | 30                 | 2   |
| 501 to 800      | 40                 | 2   |
| 801 and above   | 55                 | 3   |

**14.18.3 Flush Bolts (Fig. 14.3)**

**14.18.3.1** These should generally conform to IS 5187. These shall be of cast brass, cast aluminium alloy or extruded aluminium alloy as specified. Only one material shall be used in the manufacture of all the components of flush bolts except spring which shall be of phosphor bronze or steel strip.

When the rod is completely in its maximum bolting position it shall be retained in that position by the spring. The length of the bolt shall be such that, when the bolt is pulled down, the top of the bolt shall be flush with the top of the lip face. The top of the bolt shall be given a taper of 45° to enable easy pull or push.

**14.18.3.2** Brass flush bolts shall be satin or bright polished. Alternatively they may be nickel or chromium plated as specified in IS 4827 or copper oxidised in accordance with IS 1378. Aluminium flush bolts shall be anodised and the quality of the anodised finish shall not be less than grade AC 15 of IS 1868.



**Note :** The working of flush bolts is found satisfactory only in case of shutters made of high quality timber like teakwood properly seasoned and when there is no warping due to changes in weather Brass flush bolts which give a more satisfactory performance are costly and uses scarce materials. Hence use of flush bolts is to be discouraged.

#### 14.18.4 Floor Door Stopper (Fig. 14.4)

**14.18.4.1** The floor door stopper shall conform to IS 1823. This shall be made of cast brass of overall size as specified and shall have rubber cushion. The shape and pattern of stopper shall be approved by the Engineer-in-Charge. It shall be of brass finished bright, chromium plated or oxidised or as specified. The size of floor stopper shall be determined by the length of its plate. It shall be well made and shall have four counter sunk holes for fixing the door stoppers to the floor by means of wood screws. The body or housing of the door stopper shall be cast in one piece and it shall be fixed to the cover plate by means of brass or mild steel screws and cover plate shall be of casting or of sheet metal. The spring shall be fixed firmly to the pin. Tongue which would be pressed while closing or opening of the door shall be connected to the lower part by means of copper pin. On the extreme end a rubber piece shall be attached to absorb shock. All parts of the door stopper shall be of good workmanship and finish, burrs and sharp edges removed. It shall be free from surface and casting defects. Aluminium stopper shall be anodised and anodic film shall not be less than grade AC-10 of IS 1868.

**14.18.4.2 Sampling and Criteria for Conformity :** It shall be same as specified in 9.21.1.4.

**TABLE 14.4**  
**Requirements for Rubber**

| <i>Particulars</i>  | <i>Requirements</i> | <i>Testing procedure</i> |
|---|---------------------|--------------------------|
| Relative density Max  | 1.3                 | IS 3400 (Part IX)        |
| Hardness  | 60 ± 5              | IS 3400 (Part II)        |
| Change in initial hardness ageing for 24 hours at 100° ± 1° C | +5                  | IS 3400 (Part II)        |

#### 14.18.5 Hanging Rubber Door Stopper

**14.18.5.1** These shall be of cast brass, finished bright, chromium plated or as specified. Aluminium stopper shall be anodised and the anodic coating shall not be less than grade AC-10 of IS:1868. The size and pattern of the door stopper shall be approved by the Engineer-in-Charge. The size shall be determined by its length.

#### 14.18.6 Casement Brass Stays (Straight Peg Type) (Fig. 14.5)

**14.18.6.1** These shall be made of mild steel, cast brass, aluminium (extruded section) or plastic (Polypropylene) as specified. Mild steel casement stays shall be a copper oxidised (black finish) or as specified. Cast brass stays shall be finished bright or chromium plated or as specified. Aluminium stays shall be anodised and the anodic coating shall not be less than grade AC-10 of IS 1868. Aluminium and M.S. stays shall be made from channel section. The stays shall not weigh less than that indicated below :

|        |              |
|--------|--------------|
| 200 mm | 0.24 kg each |
| 250 mm | 0.28 kg each |
| 300 mm | 0.33 kg each |

**14.18.6.2** The shape and pattern of the stays shall be approved by the Engineer-in-Charge. The size of stays shall be determined by its length as shown in the plate. The plastic (Polypropylene) stays shall conform to IS 6318.

#### **14.18.7 Fan Light Pivots**

**14.18.7.1** These shall generally conform to IS 1837. These shall be of mild steel or cast brass or Aluminium or as specified. The brass, fan light pivots shall be finished bright, chromium plated or as specified. M.S. fan light pivot shall be copper oxidized (black finish) or as specified. The base and socket plate of M.S. fan light pivots shall be made from minimum 3.0 mm M.S. sheet and the pivot shall be of round M.S. bar of minimum 10 mm diameter projecting out by minimum 12 mm length and firmly rivetted to the base plate.

**14.18.7.2.** The base and socket plate of cast brass fan light pivots shall be made from minimum 3.0 mm thick brass plate and the projected pivot shall not be less than 12 mm diameter and 12 mm length, cast in single piece with the base plate.

**14.19 Clause shifted to Sub Head 13 (Finishing) as clause no. 13.14**

**14.20 Clause shifted to Sub Head 13 (Finishing) as clause no. 13.18**

**14.21 Clause shifted to Sub Head 13 (Finishing) as clause no. 13.19**

**14.22 Clause shifted to Sub Head 13 (Finishing) as clause no. 13.21**

#### **14.23 PAINTING READY MIXED PAINT OVER G.S. SHEETS**

**14.23.0** Ready mixed paint, suitable for painting over G.S. sheets, of approved brand and manufacture and of the required shade shall be used. New or weathered G.S. sheets shall be painted with a priming coat of one coat of redoxide zinc chromate paint. Primer shall be applied before fixing sheets in place.

##### **14.23.1 Preparation of Surface**

**14.23.1.1 *Painting New Surface*** : The painting of new G.S. sheets shall not usually be done till the sheets have weathered for about a year. When new sheets are to be painted before they have weathered they shall be treated with a mordant solution prepared by mixing 38 gm of copper acetate in a litre of soft water or 13 gm hydrochloric acid in a solution of 13 gm each of copper chloride, copper nitrate and ammonium chloride dissolved in a litre of soft water. This quantity of solution is sufficient for about 235 sqm. to 280 sqm of area and is applied for ensuring proper adhesion of paint. The painting with the mordant solution will be paid for separately.

Before painting on new or weathered G.S. sheets, rust patches shall be completely cleaned with coarse emery paper and brush. All grease marks shall also be removed and the surface washed and dried and rusted surface shall be touched with readymixed paint of red lead.

**14.23.1.2 *Painting Old Surface*** : If the old paint is firm and sound, it shall be cleaned of grease, smoke etc. The surface shall then be rubbed down with sand paper and dusted. Rusty patches shall be cleaned up and touched with red lead.

If the old paint is blistered and flaked, it shall be completely removed as described in 13.41. Such removal shall be paid for separately and painting shall be treated as on new work.

##### **14.23.2 Application**

The number of coats to be applied shall be as in the description of item. In the case of C.G.S. sheets, the crowns of the corrugations shall be painted first and when these get dried the general coat shall be given to ensure uniform finish over the entire surface without the crowns showing signs of thinning.

The second or additional coats shall be applied when the previous coat has dried.

**14.23.3** The specifications described in 13.23 shall hold good so far as they are applicable.

**14.24 Clause shifted to Sub Head 13 (Finishing) as clause no. 13.44**

**14.25 Clause shifted to Sub Head 13 (Finishing) as clause no. 13.45**

**14.26 Clause shifted to Sub Head 13 (Finishing) as clause no. 13.46**

#### **14.27 PAINTING WITH ENAMEL PAINT**

**14.27.1** Enamel Paint (conforming to IS 2933) of approved brand and manufacture and of the required colour shall be used.

For the under coat, the paint of same quality but of shade to suit that of the top coat shall be used.

**14.27.2** Preparation of surface and application shall be as specified under 13.32 for painting on new surfaces or old surfaces, as the case may be.

**14.27.3** Other details shall be as specified in 13.23 as far as applicable.

**14.28 Clause shifted to Sub Head 13 (Finishing) as clause no. 13.47**

**14.29 Clause shifted to Sub Head 13 (Finishing) as clause no. 13.48**

**14.30 Clause shifted to Sub Head 13 (Finishing) as clause no. 13.35**

#### **14.31 VARNISHING**

**14.31.0** Ordinary copal varnish or superior quality spray varnish shall be used. The work includes sizing of transparent wood filler.

**14.31.1** Varnish (conforming to IS 347) for the finishing and undercoats shall be of the approved manufacturer.

##### **14.31.2 Varnishing on New Surfaces**

**14.31.2.1 Preparation of Surface :** New wood work to be varnished shall have been finished smooth with a carpenter's plane. Knots shall be cut to a slight depth. Cracks and holes shall be cleaned of dust. The knots, cracks etc. shall then be filled in with wood putty made as follows:

On a piece of wood say 20 x 15 cm face and on the side where cross grains appear, a small quantity of glue size shall be poured and the surface scraped with the edge of a fine carpenter's chisel. Very fine wood powder shall be mixed with the glue and the stiff paste thus formed shall be used for the filling.

The fillings when dry shall be rubbed down with a carpenter's file and then the entire surface shall be rubbed down perfectly smooth with medium grained and fine sand papers and wiped with dry clean cloth so that it presents uniform appearance. In no case shall sand papers be rubbed across the grains, as in this case even the finest marks will be visible when the varnishing is applied.

**14.31.2.2 Sizing or Transparent Wood Filler Coat :** The surface shall then be treated with either glue sizing or with transparent wood filler coat as stipulated in the description of item.

(a) *Sizing* : When sizing is stipulated, an application of thin clean size shall be applied hot on the surface. When dry, the surface shall be rubbed down smooth with sand paper and cleaned. It shall then be given another application of glue size nearly cold. The sized wood work shall again be rubbed down smoothly with fine sand paper and cleaned. The surface shall be perfectly dry and all dust shall be removed not only from the surface but also from the edges and joints before varnishing is commenced. If the wood work is to be stained, the staining colour shall be mixed with the second coat of the size which must be applied evenly and quickly keeping the colour on the flow.

Any joining up with work already dry will show badly. The object of application of the glue size is to seal the pores in wood to prevent absorption of the oil in the varnish.

Glue sizing is inadvisable on floors, table tops and other horizontal surfaces likely to carry wet household utensils which are likely to disturb the size coatings and thus expose bare wood. Where glue sizing is omitted to be done the rate for the work shall be suitably reduced.

(b) *Transparent Wood Filler Coat* : Where instead of glue sizing, transparent wood filler application is stipulated in the item, then the surface prepared as described in 13.37.2.1 shall be given as application of the filler with brush or rag in such a way that the filler fills up all the pores and indentations and levels up the surface. It shall be allowed to dry for 24 hours. Then it shall be cut and rubbed with emery paper so that the surface of the wood is laid bare, with the filler only in the pores and crevices of the wood.

**14.31.2.3 Application of Varnish** : The number of coats to be applied shall be as stipulated in the description of the item.

The undercoat shall be with a flattening varnish. This dries hard and brittle and when cut and rubbed down to produce a smooth surface enhances the gloss of the finishing varnish. The top coat shall be given with stipulated brand of finishing varnish.

The varnish shall be applied liberally with a full brush and spread evenly with short light strokes to avoid frothing. If the work is vertical the varnish shall be crossed and recrossed and then laid off, latter being finished on the upstrokes so that varnish, as it sets, flows down and eliminates brush marks, the above process will constitute one coat. If the surface is horizontal, varnish shall be worked in every direction, with light quick strokes and finish in one definite direction so that it will set without showing brush marks, in handling and applying varnish care should be taken to avoid forming froth or air bubbles. Brushes and containers shall be kept scrupulously clean.

Rubbing down and flattening the surface shall be done after each coat except the final coat with fine sand paper.

The work shall be allowed to dry away from droughts and damp air. The finished surface shall then present a uniform appearance and fine glossy surface free from streaks, blister etc.

Any varnish left over in the small container shall not be poured back into the stock tin, as it will render the latter unfit for use.

Special fine haired varnishing brushes shall be used and not ordinary paint brushes. Brushes shall be well worn and perfectly clean.

**14.31.2.4** Other details shall be as specified in 13.23 as far as they are applicable.

### **14.31.3 Varnishing on Old Surface**

**14.31.3.1 Preparation of Surface** : If the old varnished surface is firm and sound it shall be cleaned of grease and dirt with turpentine and then rubbed with wet sand paper until the surface is clean and smooth. It shall be dried and wiped clean with a soft cloth. Knots, holes and cracks shall be stopped as specified in 13.37.3. The entire surface shall then be rubbed down smooth with sand paper and wiped clean.

If the old varnished surface is peeled or cracked then it will be necessary to remove the entire varnish as described in para 13.41 and such removal shall be paid for separately outside the rate for varnishing. Further the varnishing itself will have to be done like new work and will be paid for as such.

**14.31.3.2 Application** : The specification shall be same as described in 13.37.3.2 as far as applicable except that the coats to be applied will be with the stipulated quality of varnish for finishing coat.

**14.31.3.3** Other details shall be as specified in 13.23 as far as they are applicable.

### **14.32 Clause shifted to Sub Head 13 (Finishing) as clause no. 13.40**

### **14.33 DOUBLE SCAFFOLDING**

Specifications are same as described in sub head RCC work. (Figure 14.6)

### **14.34 FIXING OLD WIND TIES**

14.34.1 Specified same as described in 14.5 above. Except for the old wind tie will be used for which nothing extra will be paid. The old wind tie shall be properly cleaned off and anticorrosive bituminous paint shall be applied before fixing the same at required location of the roof sheets with new J hook and bolts and washers for resisting water from dripping through bolt of same size as existing in the bolt tie to securing the same imposition.

#### **14.34.2 Measurement**

Work shall be measured in running meter

#### **14.34.3 Rate**

The rates are include the cost of labours and materials in all the operations described above.

### **14.35 BRICK WORK IN MUD MORTAR**

#### **14.35.1 Selection of clay for mud mortar**

The clay or mixture of clays should preferably conform to the following mechanical composition. Grain size analysis shall be done in accordance with the method given in IS 2720 (Part 4): 1986.

Clay 18-22 percent by weight

Silt 40-45 percent by weight

Sand 30-40 percent by weight

The total content of clay and silt be preferably not less than 60 percent by weight.

Note:- In case of soils which are more sandy or clayey than the limits specified above, the same should be blended with more plastic clay or non-plastic materials as the case may be so as to bring the mechanical composition within the above specified limits.

Since the mud mortar is susceptible to weathering mud mortar masonry may be used for temporary structures and low rise structures having adequate lateral stability.

Thickness of mud mortar should not be more than 20mm in case of brick masonry works and 30mm in case of stone masonry works.

The masonry should preferably be plastered or pointed by cement or lime mortar externally to avoid erosion of mortar from joints.

Concentrated load should be distributed by providing plain concrete or RCC bed blocks or by using cement mortar masonry below the concentrated loads.

Note:- For mud mortar construction in seismic zones refer IS 4326 : 1976.

#### **14.35.2 Preparation of Mortar**

The soil for preparation of mud mortar should be processed so as to free from gravel coarse sand (particle size greater than 2mm) lime and kankar particles vegetable matter, etc.

Coarse grit, kankar etc. if present should be removed by wet sieving.

The sieved clay should be allowed to dry and then blended with plastic clay or a non-plastic locally available material (like rice husk, jute waste, wheat husk etc.) as the case may be so as to bring the mechanical composition within the limits specified above.

Where wet sieving is not necessary, the soil shall be lightly broken up and wetted. The wet mass shall be tempered over under the feet, repeatedly turned over big spades and then thoroughly kneaded. The kneaded mass shall than be left for rempering for at least 24 hrs with the soil being preferably covered with wet gunny bags.

Immediately before use in the masonry a small quantity of the prepared soil shall be mixed with a further quantity of water to obtain the decide consistency and workability. The total moisture content of the prepared mortar shall be in the range of 35 to 40 percent by weight of soil.

#### **14.35.3 Field Test**

For quick field observation and intermittent chucks, sample test as given in Annex-B may be made.

If the ball prepared as given in Annex-B as deformed on drying and crumbles easily when pressed lightly, it may be inferred that sand content excessive.

.If the ball is hard but shows cracks on the surface, then the sand content is insufficient.

If the soil is not found suitable, as inferred above the test should be repeated after modifying the composition of the soil, such as by mixing different proportions of two soils or by addition of sand or clay whichever is needed, for checking the stability.

### **ANNEX B FIELD TEST FOR SOIL FOR MASONRY MUD MORTAR**

B-1 The soil should be ground to a fine powder and mixed with sufficient water, added in small quantities. The mix should than be kneaded into a plastic mass of the required consistency.

B-2. Take a handful of the soil prepared in B-1 and form into a ball of about 80mm diameter.

B-3. Keep the ball in the sun for drying. When dried, examine the ball for loss of shape and surface cracks, if any.

#### **14.35.4 Measurements**

Brick work shall be measured in cubic metres unless otherwise specified. Any extra work over the specified dimensions shall be ignored. Dimensions shall be measured correct to the nearest 0.01 m i.e. 1 cm. Areas shall be calculated to the nearest 0.01 sq mtrs and the cubic contents shall be worked out to the nearest 0.01 cubic metres. All other specifications of brick work for such as bond, laying, finishing of joints, scaffolding, measurements shall be followed same as a regular brick work. The thickness of joints shall be kept 12mm uniformly

**14.35.5 Rate:** The rate shall include the cost of all materials and labour involved in all the operations described above.

#### **14.36 BRASS CURTAIN RODS**

##### **14.36.1 Material**

The brass curtain rods of required dia 20mm/25mm with wall thickness 1.25mm shall be provided with 2 no. brass brackets fixed with brass screws to the wall by means of wooden plugs/PVC Rawl Plugs. The size of brass screws shall not less than 60mm length.



#### **14.36.2 Measurements**

Curtain road shall be measured in running meter two nos. brass brackets including necessary screw.

**14.36.3 Rate:** The rate shall include the cost of all materials and labour involved in all the operations described above.

#### **14.37. FIXING MS ROUND OR SQUARE BARS IN WOODEN FRAME OF WINDOW**

The MS Square or Round Bars of 12mm shall be properly fixed on 50x6mm inner frame. The outer frame shall be made with 50x6mm flat with clear distance of 50mm from the inner frame. Both the frames should be fixed with a flat of 50x6mm with proper welding at a spacing of 30cm centre to centre all around the frame. The 4 corners of the both frames shall be diagonally connected with 50x6mm flat with proper thorough welding and removal of sludge and proper grinding with machine to have a smooth surface. The spacing of MS bars shall be kept 10cm centre to centre and the MS flats shall be fixed to the wooden frame with the MS screws of 50mm size at a 30cm spacing along the entire periphery of the outer frame. The frame should be properly cleaned with sand paper to receive the coat of primer of ready mix zinc chromate yellow primer shall be applied on the entire surface properly. The payment of the steel grill work shall be paid by weight.

##### **14.37.1 Measurements**

Steel grid shall be measured in Kg.

##### **14.37.2 Rate**

It includes the cost of labour and material involved in all the operations described above including fixing including coat of yellow zinc primer.

#### **14.38 WOODEN KARRIES FOR ROOFING**

The required size wooden karries of designated wood shall be procured. These should be properly seasoned before using in the work and shall be hoisted with suitable hoisting by means of mechanical/manual arrangements with suitable safety measures. A RCC band minimum 50mm thick shall be laid on top of brick wall over which the wooden karries shall be placed at required spacing depending upon the design/load of roof. The both end of the wooden karries having bearing on the wall to be painted with bituminous paint.

The good quality wood preservative shall be applied all round the wooden karries.

##### **14.38.1 Measurements**

Wooden karries shall be made in cubic meter and it includes every cost of material and labour/T&P required for fixing the karries in position.

##### **14.38.2 Rate**

It includes the cost of labour and material involved in all the operations described above.

#### **14.39. DOUBLE SCAFFOLDING SYSTEM UPTO SEVEN STOREY HEIGHT MADE WITH MS TUBE**

The double scaffolding made with 40mm dia and 25mm dia pipe shall be erected along the wall surface. The MS pipe of heavy duty with wall thickness 4mm shall be used for the scaffolding. The scaffolding shall be erected in double row system and at every 9m height the extra 1 row of 40mm dia pipe perpendicular to wall surface shall be provided to secure the both layer of vertical pipe in the wall for better stability. It should be strong enough to with stand all coming load / wind pressure/tilt etc. The double scaffolding consist of 2 rows of vertical with horizontal and diagonal bracing forming essentially a structure independent of the building. The bottom of the scaffolding shall be fixed in suitable MS chair on base plate of minimum 12mm thick and 25x25cm size. The plate should be properly placed firm plate concrete floor. The frame work of scaffolding made with 40mm dia MS tube 1.5m centre to centre horizontal and vertical joint with cup and lock system and MS fixtures etc. MS

tube chollies and MS tube staircase in scaffolding for working platform etc. shall also be provided. The scaffolding system shall be stiffened with bracings, runners, connection with the building etc. wherever required for inspection of work at required locations with essential safety features for the workman etc. complete as per directions and approval of Engineer-in-charge.

Note:- 1. The condition of MS tube and required claddings should be in good condition and should not have been used more than the specified time/nos. Scaffolding system shall remain the property of the contractor after completion of work.

2. This item to be used for maintenance work judiciously, necessary deduction for scaffolding in the existing item to be done.

#### **14.39.1 Measurement & Rate**

The elevational area of the scaffolding shall be measured for payment in sqm. The payment will be made once irrespective of duration of scaffolding.

#### **14.40 REPAIR TO PLASTER IN PATCHES.**

The repair to plaster of thickness 12mm to 20mm in patches of area upto 2.5 sqm shall be done with white cement polymer modified self curing mortar. Before applying the mortar cutting the patch in proper regular (square/ rectangle) shape, racking out joints and preparing the wall to receive the plaster shall be done. The payment shall be made in area of patches measured in sqm.

##### **14.40.1 Measurements**

Patch repair shall be measured in sqm.

**14.40.2 Rate:** The rate shall include the cost of all materials and labour involved in all the operations described above.

#### **14.41 – CLEANING**

##### **14.41.1 CLEANING OF WATER STORAGE TANKS**

**14.41.1.1** The Water Storage Tanks at terrace upto 2000 lt. capacity at all heights shall be cleaned with pressure water jetting with chemical mixed water with suitable pump arrangement and followed by coconut brushes, duster etc. including removal of silt, rubbish from the tank and cleaning the tank with fresh water disinfecting with bleaching powder @0.5gm per litre capacity of tank including marking the date of cleaning on the side of tank body with the help of stencil and paint and disposing of malba all complete as per direction of Engineer-in-charge. (The old date already written on tank should be removed with paint remover or black paint and if date is not written with the stencil or old date is not removed deduction will be made Rs.0.10 per litre) (if during cleaning any GI fittings or ball cock is damaged that is to be replaced by contractor at his own cost and nothing extra will be paid on this account).

##### **14.41.1.2 Measurement**

Cleaning of water storage tank shall be measured in litre.

**14.41.1.3 Rate:** The rate shall include the cost of all materials and labour involved in all the operations described above.

##### **14.41.2 CLEANING AND DE-SILTING OF GULLY TRAP**

**14.41.2.1** The gully trap/chamber shall be cleaned and de-silted in following manner:

1. Removal of rubbish mixed with earth by deployment of sufficient manual labour.
2. Disposal of the accumulated malba, rubbish to the approved dumping ground with the help of trolley/wheel barrows properly lined with PVC sheet to avoid splashes of the sewage/ rubbish on the ground.



All above mentioned 2 operations shall be done by making all adequate safety arrangement to the labour including providing them medical aid, rubber gloves, helmets, masks, oxygen cylinder etc. and make the site neat and clean after completion of work.

The payment to be making is inclusive of all operation like labour, material and T&P whichever is required.

#### **14.41.2.2 Measurement & Rate**

Cleaning and de-silting of gully trap shall be measured and payment in numbers. The payment to be making is inclusive of all operations like labours, materials and T&P whichever is required.

#### **14.41.3 CLEANING OF CHOKED SEWER LINE**

**14.41.3.1** The choked / blocked sewer line shall be cleaned in following steps:

1. The manhole covers shall be kept open for same time before the cleaning of sewer line so as to escape the foul gases.
2. Sucking the choked malba material by diesel running, vehicle mounting hydraulic operated suction/jetting cleaning machine with appropriate capacity as per requirement.
3. Disposal of the accumulated malba, rubbish to the approved dumping ground with the help of trolley/wheel barrows properly lined with PVC sheet to avoid splashes of the sewage/ rubbish on the ground.

All above mentioned 2 operations shall be done in presence of supervisor and by making all adequate safety arrangement to the labour including providing them medical aid, rubber gloves, helmets, masks, oxygen cylinder etc.

#### **14.41.3.2 Measurement & Rate**

Cleaning and desilting of sewer line shall be measured and payment in numbers. The payment to be making is inclusive of all operations like labours, materials and T&P whichever is required.

#### **14.41.4 CLEANING OF UNDERGROUND SUMP, OVER HEAD R.C.C. TANK**

The process of cleaning of underground sump, Over Head R.C.C. Tank (independent staging) will be done in following operations:-

1. Tank shall be emptied of water by pumping & bottom shall be cleaned of silt and other deposits.
2. Entire surface area of the sump shall be cleaned with pressure jetting of water mixed with cleaning chemical atleast two times and thoroughly etc. and finally washing with simple water jet to clean properly the wall surface.
3. Chlorination of RCC internal surface by liquid chlorine.
4. The treated surface shall be dried using air jetting and all loose particles shall be removal from the surface.
5. Finally the surface shall be treated with ultraviolet radiation etc. as per direction of Engineer-in-Charge.

All above mentioned four (4) operations shall be done by making all adequate safety arrangement to the labour including providing them medical aid, rubber gloves, helmets, masks etc.

#### **14.41.4.1 Measurement**

Cleaning of internal surface area of underground sump, Over Head RCC tanks shall be measured in sqm.

**14.41. 4.2 Rate:** The rate shall include the cost of all materials and labour and T&P involved in all the operations described above.

#### **14.42 DISCONNECTING DAMAGED OVERHEAD/TERRACE**

The execution/operation of the item is as under:

1. Closing the water supply line tank by means gate valve /stop cock etc.
2. Emptying the water tank completely.
3. The Water tank supply connection will be disconnected and the delivery pipe line shall also be disconnected by removing all the fitting and fixtures completely.
4. The delivery pipes from the bottom of the tank shall also be disconnected from the tank.
5. Removing the water storage tank from terrace and shifting it to the ground floor by mechanical means or by manual with all safety reasons as directed by Engineer-in-charge.

##### **14.42.1 Measurement & Rate**

The measurements of overhead/ terrace PVC water storage tanks of any size shall be measured in numbers and payment shall be made on each basis.

#### **14.43 REPLACEMENT OF OLD DAMAGED W.C. SEATS**

The execution/operation of the item is as under:

1. Dismantling and taking out the old WC seat and "S" or "P" trap at site complete with all operations including all necessary materials, labour and disposal of dismantled material i/c malba, debris etc. including lead upto dumping ground.
2. Providing "S" or "P" trap and water closet squatting pan (Indian type) of approved brand of good quality.
3. Fixing the W.C. with trap in position along with trap by making all arrangement of connecting it to the flushing cistern. Thereafter the gap left in the filled up portion is to be leveled by cement concrete 1:5:10 and floor tiles of same shade are also to be provided over it to match the floor of the toilet.

##### **14.43.1 Measurement & Rate**

The measurements and payment of replaced W.C Seats shall be made on each basis

#### **14.44 CUTTING HOLES OF REQUIRED SIZE IN BRICK MASONRY WALL**

Cutting holes of required size in brick masonry wall for fixing of exhaust fan including providing and fixing 300mm dia PVC pipe conforming BIS-12818 and making good the same etc. complete. The hole shall be cut with cutting tool by marking hole all round the circle with the help of power drill machine so that the adjoining wall should not get damaged.

##### **14.44.1 Measurement & Rate**

The measurements and payment of cutting holes and finishing etc. shall be made on each basis

#### **14.45 DISMANTLING W.C. PAN OF ALL SIZES**

Dismantling W.C. Pan of all sizes including disposal of dismantled materials i/c malba all complete as per directions of Engineer-in-Charge. The W.C. seat is taken out along with trap and the area is to be cleaned off all dust and rubbish etc. Thereafter the hole left in the flooring is to be leveled by cement concrete 1:5:10 and floor tiles of same shade are also to be provided over it to match the floor of the toilet room.

##### **14.45.1 Measurement & Rate**

The measurements and payment of dismantling W.C. Pan of all sizes shall be made on each basis.

#### **14.46 HACKING OF CC FLOORING**

Hacking the CC flooring including cleaning the surface etc. complete as per direction of the Engineer-in-Charge. The hacking of CC flooring is done with chisel and hammer to make the top surface of flooring rough before laying tile/ marble/granite flooring etc. The hacking should be at least 10 nos. in 30x30cm area of the floor.

##### **14.46.1 Measurement & Rate**

The measurements and payment of hacking of CC flooring shall be made on sqm.

#### **14.47 DISMANTLING 15 TO 40MM DIA G.I. PIPE**

Dismantling 15 to 40mm dia G.I. pipe including stacking of dismantled pipes (within 50 metres lead) as per direction of Engineer-in-Charge. The pipe dismantling is done from tap point to main line. The 15mm dia is to be dismantled first and thereafter the dismantling/taking out the pipe shall proceed towards bigger dia pipe at the last. The pipe is removed from its joints/sockets/T-section gently with pipe wrench/tool so that the old pipe is not get damaged and the same can be reused where required. The old dismantle pipe will be stacked dia wise and connected fittings are also to be stored properly for reuse.

##### **14.47.1 Measurement & Rate**

The measurements and payment of **Dismantling G.I. pipe** shall be made on meter.

#### **14.48 TAKING OUT EXISTING WOODEN DOOR SHUTTER AND RE-FIXING THE SAME AFTER REPAIRS**

Taking out existing wooden door shutter, repair by de-screwing hinges etc. and re-fixing the repaired door shutters to existing door frames, including replacement of hinges with screws etc. as required, all complete as per the direction of the Engineer-in-charge. The old shutter is to be taken out by removing the screws from the hinges by screw driver/screw fixing equipment (electric driven). Thereafter, the damaged part of the shutters such as styles/ panels/veneering etc. is replaced with new one and the door shutter is prepared for re-fixing to the door frame. During re-fixing the position of hinges if required may be shifted for proper anchorage with 50mm stainless steel screw with cross head. The re-fixing with butt hinges by means of screws is done with the help of electric driven screw driving equipment. The whole door including chokhat is to be re-painted with required colour to match the door and shutter with the same shade.

##### **14.48.1 Measurement & Rate**

The measurements and payment shall be made on each basis.

#### **14.49 WATER PROOFING TREATMENT WITH APP (ATACTIC POLYPROPYLENE POLYMERIC) MEMBRANE**

Water proofing treatment of roofs with APP modified polymeric membrane shall be either five course, seven course as specified in the item. In selecting the combinations of layers of APP membrane, consideration shall be given to the type and construction of buildings, climate and atmospheric conditions and the degree of permanence required. Five course treatment is a normal treatment suitable to moderate rainfall conditions (less than 50 cm.) and seven course treatment is suitable for heavy rainfall (50 cm and above). Seven course treatment with APP modified polymeric membrane 2.00 mm thick and weight 3.00 kg./sqm. to suitable for very heavy conditions of rainfall (more than 150 cm.).

##### **14.49.1 Materials**

14.49.1.1 The bitumen primer shall conform to the requirements laid down in IS 3384.

14.49.1.2 APP Modified Membrane: It is a polymeric water proofing membrane manufactured to high standards. It is five layered APP modified polymeric membrane with centre core as 20 micron HMHDPE/ 100 micron HMHDPE High Molecular High Density Polyethylene Film, is the heart of the membrane and protects against water and moisture. The centre core is sandwiched on both sides by high quality polymeric mix with properties of high softening point, high heat resistance and cold resistively to make it ideal for all water proofing treatment. The polymeric mix is protected on both sides with 20 micron HMHDPE film. The membrane is available in variable thickness and weights. Usual width is 1.0 m.

Important physical and chemical parameter of the membrane shall be as given in Table 14.5 for guidance.

**TABLE 14.5**

| Centre Core       | Film             | Thickness | Weight         |
|-------------------|------------------|-----------|----------------|
| 20 micron HMHPDE  | 20 micron HMHPDE | 1.5 mm    | 2.25 kg/ sqm.  |
| 100 micron HMHPDE | 20 micron HMHPDE | 2.00 mm   | 3.00 kg./ sqm. |

Where proprietary brands Atactic Polypropylene modified polymeric membrane is proposed to be used by the contractor, they shall conform in all respect to the specification in the preceding paras and manufactured by a company of repute.

**14.49.1.3 Bonding Material:** This shall consist of blown type bitumen conforming to IS 702 or residual bitumen 85/25 conforming to IS 73 heated to the correct working temperature of 180°C. The penetration of the bitumen shall not be more than 40 when tested in accordance with IS 1203, unless otherwise specified each coat of bonding material shall be of blown type bitumen of grade 85/25 heated to a working temperature of 180 degree C and applied @ 1.20 kg. per square metre of the surface area.

**14.49.1.4 Surface Finish:** Surface finish shall be with brick tiles of class designation 100 grouted with cement mortar 1:3 (1 cement : 3 fine sand ) with 2% integral water proofing compound by weight of cement over a 12 mm thick layer of cement mortar 1:3 (1 cement: 3 fine sand) and finished neat, as shown in Fig. 14.7. Surface finish shall be measured and paid for separately.

**14.49.1.5 Preparation of Surface:** The surface to be treated shall have a minimum slope of 1 to 120. This grading shall be carried out with cement concrete or cement plaster with coarse sand, as desired, to the average thickness required and finished smooth. Such grading shall be paid for separately.

Junctions between the roof and vertical faces of parapet walls, chimneys etc. shall be chased by running triangular fillets 7.5 x 7.5 cm. size, cement concrete. At the drain mouths, the fillets shall be suitably cut back and rounded off for easy application of water proofing treatment and easy flow of water. Cement concrete where shall be 1:2:4 mix (1 Cement: 2 Coarse sand: 4 Graded stone aggregate 20 mm. Nominal size). The provision of fillets shall be deemed to be covered by the item of water proofing and shall not be measured or paid for separately.

In existing roof where gola and drip course are provided at the junction of roof and vertical face of parapet wall, chimney stacks, etc. These shall be dressed suitably and finished smooth so as to ensure an easy and gradual turning of the flashing. Any dismantlement or forming and finishing smooth the junction for forming the base of the flashing shall not be measured or paid for separately and shall be deemed to form part of the preparation of the surface.

While the grading of roof surface is being done, it shall be ensured that the outlet drain pipe have been fixed and mouth at the entrance have been eased and rounded off properly for easy flow of water. When any pipe passes through the roof to be treated, angular fillet of shape shown in Fig. 22.11 shall be built around it for the water proofing treatment to be taken over it. These fillets shall not be measured or paid for separately. For carrying over and tucking in the water proofing felts into the parapet walls, chimneys stacks etc. a horizontal groove 6.5 cm. deep, 7.5 cm. wide section with its lower edge at not less than 15 cm. above the graded roof surface shall be left on the inner face of the same; during construction if possible. When such groove has not been left, the same shall be cut out neatly and the base at rear of the groove shall be finished smooth with cement plaster 1:4 (1 cement: 4 coarse sand). Such cutting of the groove and its finishing smooth shall be part of the water proofing or paid for separately. No deduction shall be made either for not making the groove or when the latter has already been left in the masonry by the construction agency. Tucking in the water

proofing felt will be required where the parapet wall exceeds 45 cm. in the height from the graded surface. Where the height is 45 cm. or less, no groove will be required as the water proofing treatment will be carried over the top of the parapet wall to its full thickness. In the case of low dividing walls of height 30 cm. or less, outlets therein shall be cut open for full height and the bottom and sides shall be rendered smooth and corners rounded and such treatment shall not be measured and paid for separately. Where expansion joints are left in the slab the provision of dwarf walls and/or RCC slabs for covering them and finishing the surface smooth shall be the responsibility of the construction agency, which had laid the roof slab and will not be included in the operation of water proofing. The graded surface of the roof and concrete fillets and the faces of walls shall be thoroughly cleaned with wire brushed and all loose scales etc. removed. The surface shall then be dusted off. Any crack in the roof shall be cut to V section, cleaned and filled up flush with cement mortar slurry 1:4 (1 cement : 4 coarse sand) or blown type petroleum bitumen of IS grade 85/25, or approved quality conforming to IS 702. Such cleaning of the surface or treating the cracks shall not be paid for separately.

**14.49.1.6 Treatment:** The water treatment shall be of five or seven course as specified.

In seven course treatment, the first four courses shall be the same as for five course treatment. The fifth course shall be a layer of APP modified polymeric membrane. The sixth course shall be a coat of bonding material and the top most seventh course shall be of specified surface finish.

**14.49.1.7 Laying**

- (a) First course shall be a coat of bitumen primer @ 0.40 kg per sqmt followed by subsequent course as per treatment required.
- (b) Drain outlets shall be given a four or six course treatment as specified for the roof in the description of the item in the manner specified for the flat roof surface. Water proofing treatment shall be carried into the drain pipe or outlets by at least 10 cm. The water proofing treatment laid on the roof surface shall overlap the upper edge of the water proofing treatment in the drain outlets by at least 10 cm.
- (c) The APP modified polymeric membrane shall be cut to the required length, brushed clean of dusting material and laid out flat on the roof to eliminate curls and subsequent stretching. The membrane shall normally be laid in length in the direction of the slope and laying shall be commenced at the lowest level and worked up to crest. The membrane shall not be laid in single piece of very long lengths as they are likely to shrink; 6 to 8 m are suitable lengths. The roof surface shall be cleaned and dry before starting the membrane treatment. Each length of membrane shall be laid in position and rolled up for a distance of half its length. The hot bonding material shall be poured on the roof across the full width of the rolled membrane as the latter is steadily rolled out and pressed down. The pouring shall be so regulated that the correct weight of bonding material per unit area is spread uniformly over the surface. Excess bonding material that gets squeezed out at the ends shall be levelled up as laying proceeds. When the first half of the strip of felt has been bonded to the roof, the other half shall be rolled up and then unrolled on the hot bonding material in the same way. Subsequent strips shall also be laid in the same manner.

Each strip shall overlap the preceding one by at least 7.5 cm. at the longitudinal edges and 10 cm. at the ends. All overlaps shall be firmly bonded with a blow lamp and levelling down unevenness. The fourth layer of bonding material in the five course treatment shall be carried out in a similar manner after the flashing has been completed.

- (d) In a seven course treatment the fifth layers of membrane shall be laid in the manner already described, taking care that laps in the membrane are staggered from those in the earlier layer. The sixth layer of bonding material shall be carried out after the flashing is done.



- (e) High Parapet Walls, Chimney Stacks etc.: Membrane shall be laid as flashing wherever junctions of vertical and horizontal surfaces occur. Longitudinal laps shall be 10 cm. The lower layer of flashing membrane in a six course treatment shall overlap the roof water proofing by not less than 20 cm. while the upper layer shall overlap the roofing felt by 10 cm. The minimum overlap of the flashing membrane in five course treatment over the roofing membrane shall be 10 cm.

The flashing shall consist of the same five or seven course treatment as for the roof except that the final course shall be replaced by an application of 12 mm thick cement plaster 1:3 on the vertical and sloping faces only, of the flashing as shown in Fig 14.8. The overlap along the length of flashing shall stagger with those in the second layer of flashing membrane (in a seven course treatment and with the joints in the roof membrane).

The upper edge of the finishing membrane shall be well tucked into the flashing grooves in the parapet, chimney stacks etc. to a depth of not less than 6.5 cm. Corresponding applications of bonding material shall also be made. The flashing treatment shall be firmly held in place in the grooves with wood edges at intervals and the grooves shall be filled up with cement mortar 1:4 (1 cement: 4 coarse sand) or cement concrete 1:2:4 (1 cement: 2 coarse sand : 4 graded stone aggregate 6 mm nominal size) and surface finished smooth with the rest of the wall. The cement work shall be cured for 7 days. When dry, the exposed plaster joints of grooves shall be painted with bitumen and two coats of bituminous solution shall be applied on the vertical and sloping surface of flashing (see Fig. 14.7).

After the top flashing membrane layer has been fixed, the penultimate layer of bonding material shall be applied over the roofing membrane and the horizontal overlaps and vertical and sloping surfaces of the flashing at the specified rate.

- (f) Low Parapet Walls: Where parapet walls are of height 45 cm. or less, membrane flashings shall be provided in the same manner as for flashings in the case of high parapet walls except that the upper edge shall be carried upto the full height of the wall and taken right across the top of the parapet and down on the external vertical faces to a minimum distance of 5 cm. (see Fig 14.8).
- (g) Low Dividing Walls: Where low dividing walls or inverted beams are met with, the same shall be covered with a four or six layer treatment as for the main roof, the latter bearing carried down both sides of the wall and overlapping the roofing treatment as in the case of flashing of high parapet walls (see Fig. 14.10).

Drain outlets where formed in the low dividing walls, shall be given water proofing treatment of the same number of courses as specified for the flat roof surface. The bottom and sides shall be so treated that all overlaps are in the direction of flow of drainage.

- (h) Expansion Joints: Where the expansion joints are provided in the slabs, the joints and their cover slabs shall be suitably treated with water proofing. A typical sketch of an expansion joint with the RCC slabs on either side of the joint turned vertically up and dwarf walls by not less than 7.5 cm. and are provided with throatings on their underside along their length. The water proofing treatment shall be taken up the sloping junction fillets and the vertical faces of the walls to the underside of the cover slabs. The cover slabs are given the water proofing treatment like the roofs slabs, after the cross joints between adjacent cover slabs are first sealed with 15 cm width of roofing felt struck to them with bitumen. The water proofing treatment shall be carried down the sides of the cover slabs to their full thickness. Care shall be taken to see that overlaps if any in the roofing over the cover slabs stagger with the joints between cover slabs.

The formation of the expansion joints and provision of the cover slabs shall be the responsibility of the construction agency. The formation of the junction fillets and the water proofing treatment of the joint and cover slabs shall be carried out by the water proofing agency. Nothing agency extra shall be paid for the sealing of the cross joints in the cover slab with 15 cm. width of bitumen strips.

- (i) Pipes: Where vertical pipe outlets are met with, 7.5 x 7.5 cm fillets of lime or cement concrete of the type and section shown in Fig. 14.10 shall be provided and flashing of four or six course treatment, same as for the roofing treatment shall be laid.

The upper edge of the flashing shall be laid sloping down forward and butted against the pipe and annular depression so formed shall be filled with hot bitumen. A circular metal collar in the shape of an inverted truncated cone shall be fixed on the pipe to throw off the rain water clear of the flashing and this shall be paid for separately.

**14.49.1.8 Measurement:** Length and breadth shall be measured correct to a cm. The area shall be calculated in square metres correct to two places of decimal. Measurements shall be taken over the entire exposed area of roofing and flashing treatment including flashing over low parapet walls, low dividing walls and expansion joints and at pipe projections etc. Overlaps and tucking into flashing grooves shall not be measured. Vertical and sloping surfaces of water proofing treatment shall also be measured under the five or seven course treatment as the case may be, irrespective of the fact that the final course is replaced by bitumen primer. No deduction in measurements shall be made for either openings or recesses for chimney stacks, roof lights and the like, for areas upto 0.4 sqm nor anything shall be paid for forming such openings. For areas exceeding 0.40 sqm deduction will be made in measurements for full opening and nothing extra shall be paid for forming such openings.

**14.49.1.9 Rate:** The rate shall include the cost of all labour and materials involved in all the operations described above. The top most layer shall be paid for separately.

#### **Clause 14.49 brought from Sub Head 22 (Water Proofing) clause no 22.11**

#### **14.50 FIVE LAYERED WATER PROOFING TREATMENT WITH ATACTIC POLYPROPYLENE POLYMER MODIFIED PREFABRICATED MEMBRANE**

**14.50.1** Atactic Polypropylene Polymer modified prefabricated five layer water proofing membrane shall be of thickness as specified. In selecting thickness of membrane due consideration shall be given to the type and construction of building, climate and atmospheric condition and permanence required. Five layered treatment 2.00 mm thick with glass fibre is with a normal duly treatment suitable for pitched roofs. Five layered 3.00 mm thick with glass fibre matt treatment is suitable for moderate condition of rainfall (50 to 150 mm) and fine layered 3.00 mm thick with non-woven polyester matt treatment is suitable for heavy condition of rainfall.

##### **14.50.1.1 Materials**

Bitumen primer for bitumen membrane shall have density at 25°C in the range of 0.87 - 0.89 kg./litre and viscosity of 70-160 CPS primer shall be applied @ of 0.40 litre/sqm.

**14.50.1.2** Atactic Polypropylene Polymer Modified Prefabricated Membrane: It is a polymeric water proofing membrane. This shall be one of the following types:

- (i) 2 mm thick with glass fibre matt.
- (ii) 3 mm thick glass fibre matt.
- (iii) 3 mm thick with non-woven polyester matt.

It is prefabricated five layered black finish water proofing membrane comprising of centre core of 50 gsm. Glass fibre matt/170 gsm nonwoven polyester matt sandwiched on both sides by APP polymer modified bitumen which is protected on both sides by 20 micron thermofusible polyethylene sheet. Composite thickness of the membrane including all five layers shall be 2/3 mm with glass fibre matt and 3 mm with non woven polyester matt. It is available in 1 m width and variable lengths.

Physical and chemical parameters of the membrane shall be as given in Table 14.6

TABLE 14.6

| Sl. No. | No. of Layers  | Thickness | Elongation at 23° C in longitudinal transverse direction | Joint strength in longitudinal and Transverse direction | Tear strength in longitudinal Transverse direction | Softening Point | Cold flexibility |
|---------|--|-----------|--|---|--|-----------------|------------------|
| 1       | 2  | 3         | 4  | 5   | 6  | 7               | 8                |
| 1       | Five Layered reinforced with fibre glass               | 2 mm      | 3 N/5 cm.  | 350/300 N/5 cm.   | 60/80 N  | 150°            | -2°C             |
| 2       | Five layered reinforced with fibre glass               | 3 mm      | 3.3 N/5 cm.  | 350/3000 N/5 cm.  | 60/80 N  | 150°            | -3°C             |
| 3       | Five layered reinforced with non-woven polyester matt. | 3 mm      | 40/50 N/5 cm.  | 650 N/450 N/5 cm.                                       | 300/250 N  | 150°            | -2°C             |

When tested Atactic polypropylene modified black finished is proposed to be used shall conform in all respects to the specification in the preceding paras. The work should be got done through authorized applicator/ specification agency.

**14.50.1.3 Preparation of Surface:** The surface to be treated shall have a minimum slope of 1 in 120 or as specified, provision specified in clause 14.49.1.5 shall apply for preparation of surface except for pitched roof where surface shall be cleaned off any loose material dust etc.

To ensure good adhesion between the surface and water proofing treatment suitable method to dry the surface shall be adopted. All hair line cracks in the surface should be filled with approved sealant.

**14.50.1.4 Treatment:** The water proofing shall consist of prefabricated five layered 2 mm / 3 mm membrane as shown in Fig. 14.11. The choice of 2 mm or 3 mm membrane will depend on the type of roof i.e. pitched or flat and importance of building, durability, cost and rainfall etc.

**14.50.1.5 Laying:** Bitumen primer @ 0.40 lts/sqm shall be applied to the prepared roof, drain and all other surfaces where polymer modified membrane is to be laid. The five layered water proofing membrane shall be laid using Butane torch and sealing all joints and preparing the surface complete. Drain outlets shall be given same treatment as specified for the roof in the description of the item in the manner specified for the flat roof surface. Water proofing treatment shall be carried into the drain pipe or outlets by at least 10 cm. The water proofing treatment laid on the roof surface shall overlap the upper edge of the water proofing treatment in the drain outlets by at least 10 cm.

The APP polymer modified prefabricated water proofing membrane shall be cut to the required length. Water proofing membrane shall normally be laid in length in the direction of the slope and laying shall be commenced at the lowest level and worked upto crest. APP water proofing membrane shall be laid in 6 to 8 m lengths. The roof surface shall be cleaned and bitumen primer shall be applied in the correct quantity, over this specified water proofing membrane shall be laid with butane torch after allowing 24 hours for primer to dry. Each strip shall overlap the preceding one by at least 10 cm. at the longitudinal edges and 15 cm. at the ends. All overlaps shall be firmly bonded with bitumen primer and levelled by heating the overlap with butane torch.



If the roof is accessible the treatment is protected by brick tiles laid over 12 mm thick cement mortar of specified grade bedding and joints sealed with cement mortar of which shall be measured and paid for separately.

APP water proofing membrane shall be laid as flashing wherever junction of vertical and horizontal surfaces occur. Longitudinal laps shall be 10 cm. The upper edge of flashing membrane shall be well tucked into the flashing grooves in the parapets, chimney stack etc. to a depth of not less than 6.5 cm; corresponding applications of primer coat shall also be made. The flashing treatment shall be firmly held in the grooves and it shall be sealed with the approved sealant after terminating the membrane.

Where parapet walls are of height 45 cm or less AP water proofing membrane flashing shall be provided in the same manner as for splashing in the core of high parapet walls except that upper edge shall be carried out the full height of the wall and taken right across the top of the parapet and down on the external vertical faces to a minimum distance of 5 cm.

Where low dividing walls or inverted beams are met with, the same treatment shall be provided as for the main roof, the lateral bearing carried down both sides of the wall and overlapping the roof treatment.

Drain outlets where formed in the low dividing walls, shall be given water proofing treatment same as for the main roof.

Where the expansion joints are provided in the slabs, the joints and their cover slabs shall be suitably treated with water proofing treatment. A typical sketch of an expansion joint with the RCC slabs on either side of the joint turned vertically up and covered with precise RCC cover slabs as given in Fig. 14.10. The cover slabs shall cover the vertical turned up dwarf walls by not less than 7.5 cm and are provided with throatings on their underside along their length. The water proofing treatment shall be taken up the slopping junction fillets and the vertical faces of the walls to the underside of the cover slabs are given the water proofing treatment like the roof slabs, after the cross joints between adjacent cover slabs are first sealed with 15 cm. width of roofing felt struck to them with bitumen. The water proofing treatment shall be carried down the sides of the cover slabs to their full thickness. Care shall be taken to see that overlaps if any in the roofing over the cover slabs stagger with the joints between cover slabs.

The formation of the expansion joints and provision of cover slabs shall be the responsibility of construction agency. The formation of the junction fillets and the water proofing treatment of the joint and cover slabs shall be carried out by the water proofing agency. No extra shall be paid for the junction fillets or for the sealing of the cross joints in the cover slab with 15 cm. width of bitumen strips.

**14.50.1.6 Measurements:** Length and breadth shall be measured correct to a cm. The area shall be calculated in square metres correct to two places of decimal.

Measurement shall be taken over the entire exposed area of roofing and flashing treatment including flashing over low parapet walls, low dividing walls and expansion joints at pipe projections etc. overlaps and tucking into flashing grooves shall not be measured.

No deduction in measurements shall be made for either openings or recesses for chimney stacks, roof lights and the like, for areas upto 40 square decimeter (0.4 sqm.) nor any thing shall be paid for forming such openings. For areas exceeding 0.40 sqm. deductions will be made in measurements for full opening and nothing extra shall be paid for forming such openings.

**14.50.1.7 Rate:** The rates shall include the cost of all labour and materials involved in all the operations described above.

**Clause 14.50 brought from Sub Head 22 (Water Proofing) clause no 22.12**

#### **14.51 EXTRA FOR COVERING OF APP MODIFIED PREFABRICATED MEMBRANE WITH GEOTEXTILE**

**14.51.1** If the water proofing treatment of flat roof has been done with APP modified five layered membrane and the roof is accessible, a separation layer on top of membrane should be laid before any protected treatment is done. Brick tiles in cement mortar or 25 mm thick cement concrete 1:2:4 shall be laid as final layer as shown in Fig. 14.11.

Geotextile 120 gm. Non woven 100% polyester of thickness 1.0 to 1.25 mm manufactured by a company of repute shall be used.

Geotextile of the specified thickness is bonded to the water proofing membrane with intermittent touch by heating the membrane by Butane torch as per manufacturing recommendations.

**14.51.2 Measurements:** Length and breadth shall be measured correct to two places of decimal, measurement shall be taken over the entire exposed area of roofing.

**14.51.3 Rate:** The rate shall include the cost of all labour and material involved in all the operation described above. Final layer of brick tiles or 25 mm thick cement concrete shall be measured and paid for separately.

#### **Clause 14.51 brought from Sub Head 22 (Water Proofing) clause no 22.13**

#### **14.52 PROVIDING ROUND THE CLOCK SECURITY GUARD WITHOUT GUN**

Providing round the clock healthy security guard without gun for watch & ward of Government premises and its all belongings by deploying neatly dressed security guards in 8 hour's shift including necessary T&P like torch, lathi and uniform etc. complete, as per the direction of Engineer-in-charge. (One job means 8 hour's duty). Minimum qualification of security guard should be 10th class passed.

#### **14.53 PROVIDING ROUND THE CLOCK SECURITY GUARD WITH GUN**

Providing round the clock healthy security guard with gun for watch & ward of Government premises and its all belongings by deploying neatly dressed security guards in 8 hour's shift including necessary T&P like torch, lathi and uniform etc. complete, as per the direction of Engineer-in-charge. (One job means 8 hour's duty). Minimum qualification of security guard should be 10th class passed.

The suggestive condition for item no. 14.52 & 14.53 are as under:-

1. The agency should have been registered with M/o Defence or Registrar Office for purpose of watch & ward.
2. The Manpower deployed for the watch & ward will be in proper uniform.
3. The agency should get the employees under valid insurance till whole period of agreement.
4. During period of watch & ward any kind of loss / theft / damage to the govt. property / premises will be compensated by the agency.
5. In case of any loss of material/damage of the property during the watch & ward period the FIR to the police will be lodged immediately.
6. The Manpower deployed for the work shall be well equipped with torch, lathi, whistle, gun of valid license from appropriate authority whatsoever as per requirement of the work.

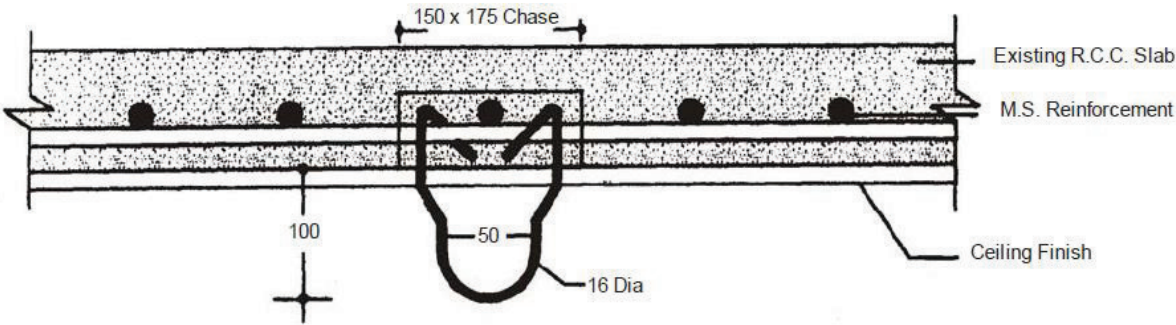
#### **14.53.1 Measurements:**

*The mode of measurements of security guard shall be measured on job/shift basis around the clock (8hrs x 3 shifts for 24 hours) and complete month.*

**14.53.2 Rate:** The rate of security guards on job basis and i/c the cost of all labour and T&P involved in all the operation described above.

# FIXING OF FAN CLAMPS IN EXISTING R.C.C. SLABS

Sub Head : Repairs to Buildings  
Clause : 14.12

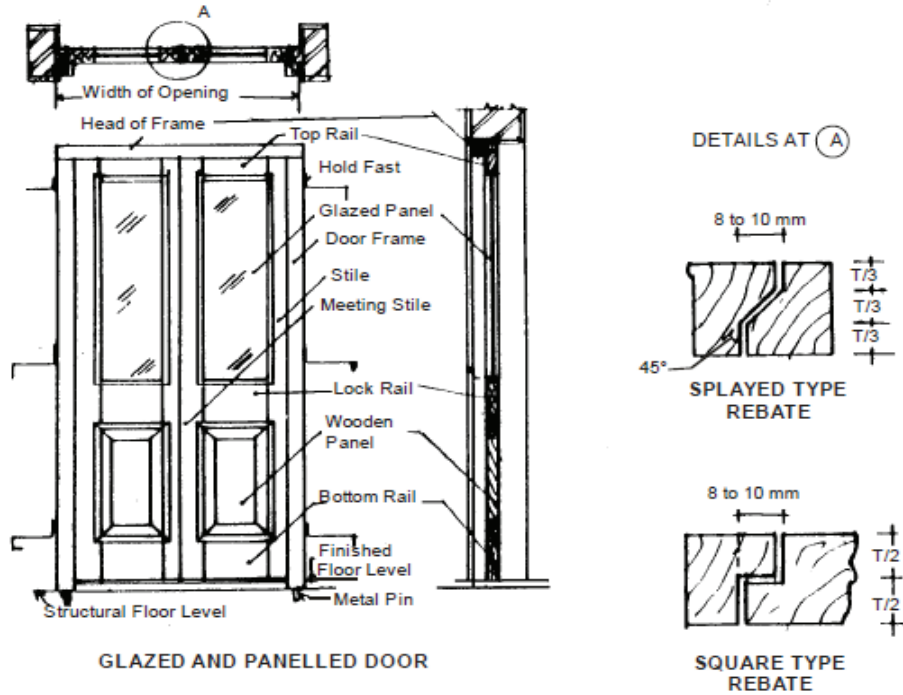


Drawing Not to Scale  
All dimensions are in mm

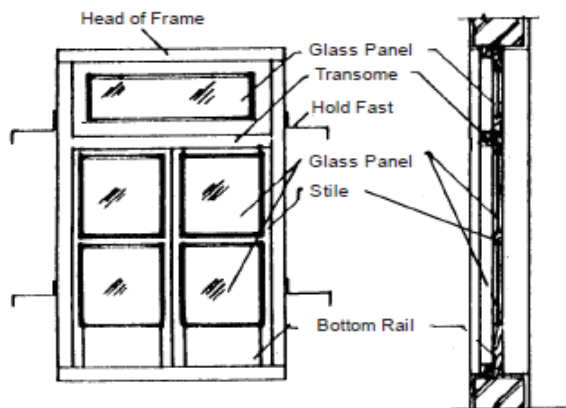
Fig. 14.1 : Fixing of Fan Clamps in Existing R.C.C. Slabs

# TERMINOLOGY TIMBER DOOR, WINDOW & VENTILATOR COMPONENTS

Sub Head : Repairs to Buildings  
 Clause : 14.16



GLAZED AND PANELLED DOOR



TOP HUNG VENTILATOR



CENTRE HUNG VENTILATOR



BOTTOM HUNG VENTILATOR

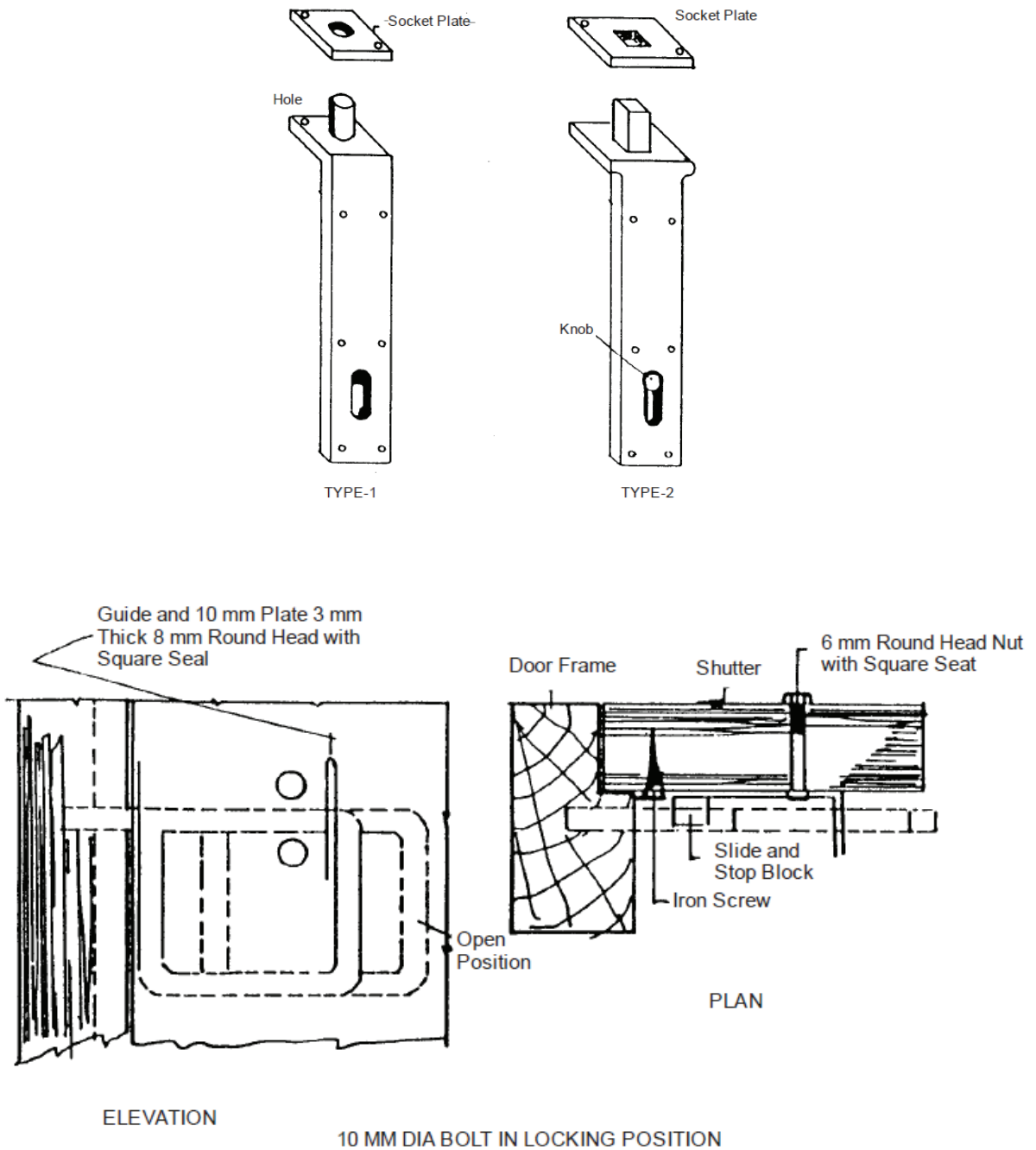
## WINDOWS AND VENTILATORS

Drawing Not to Scale  
 All dimensions are in mm

Fig. 14.2 : Terminology Timber Door, Window & Ventilator Components

# FLUSH BOLTS

Sub Head : Repairs to Buildings  
 Clause : 14.18.3

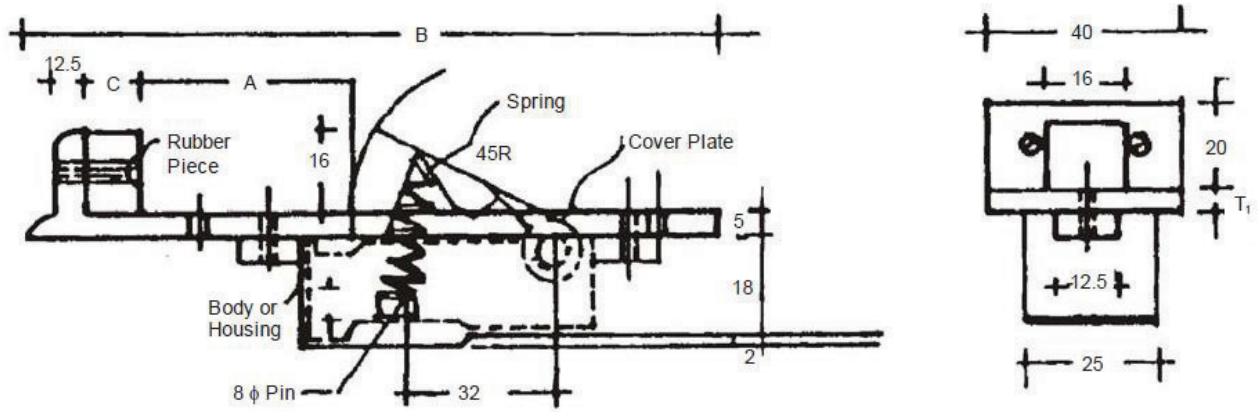


Drawing Not to Scale

**Fig. 14.3 : Flush Bolts**

## FLOOR DOOR STOPPER

Sub Head : Repairs to Buildings  
Clause : 14.18.4



### Floor Door Stopper - Cast Type

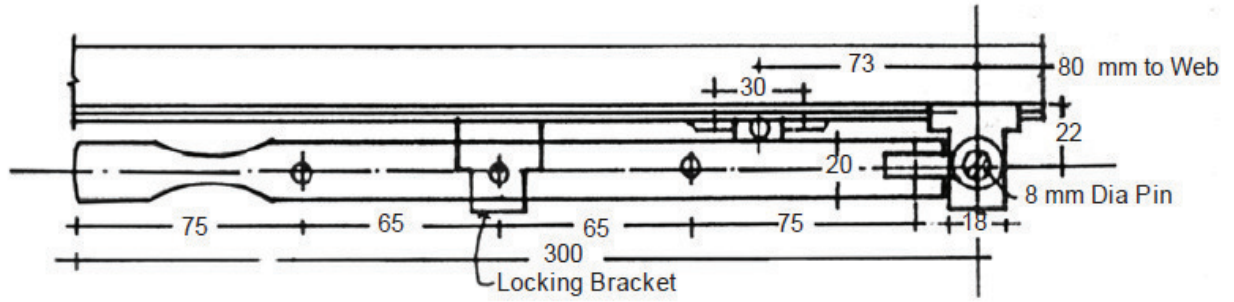
| Thickness of Door Shutter | Dimensions |             |    | Casting T <sub>1</sub> | Screw Designation No. | No. of Holes For T <sub>1</sub> |
|---------------------------|------------|-------------|----|------------------------|-----------------------|---------------------------------|
|                           | A          | B           | C  |                        |                       |                                 |
| 30                        | 35.0 ± 0.5 | 140.0 ± 0.5 | 13 | 4.5 ± 0.3<br>- 0       | 9                     | 4                               |
| 35                        | 40.0 ± 0.5 | 140.0 ± 0.5 | 8  | 4.5 ± 0.3<br>- 0       | 9                     | 4                               |
| 40                        | 45 ± 0.5   | 150.0 ± 0.5 | 13 | 4.5 ± 0.3<br>- 0       | 9                     | 4                               |
| 45                        | 50.0 ± 0.5 | 150.0 ± 0.5 | 8  | 4.5 ± 0.3<br>- 0       | 9                     | 4                               |

Drawing Not to Scale  
All dimensions are in mm

**Fig. 14.4 : Flush Door Stopper**

# WINDOW STAY

Sub Head : Repairs to Buildings  
Clause : 14.18.6

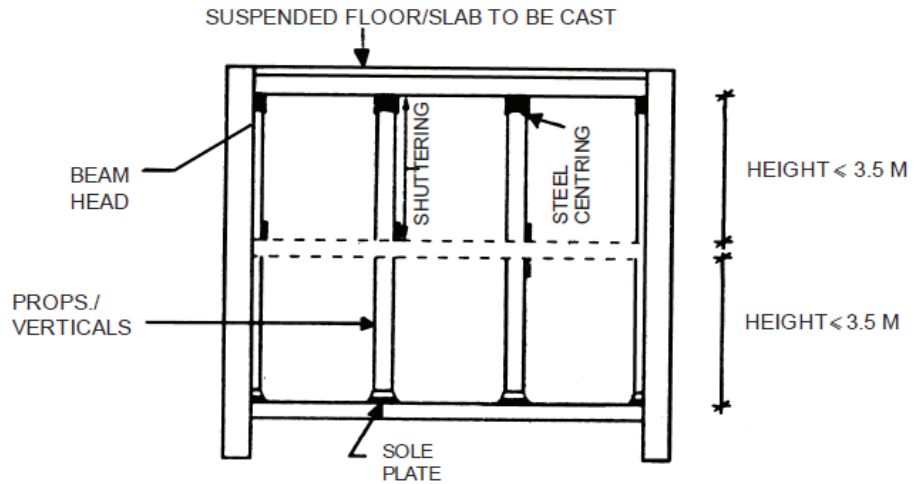


Drawing Not to Scale  
All dimensions are in mm

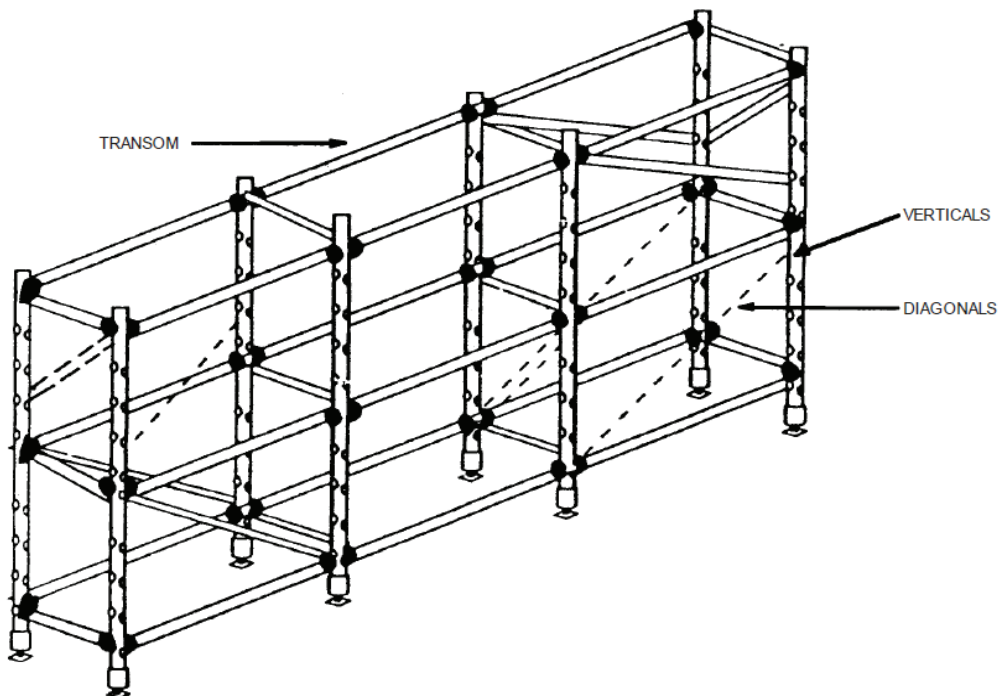
Fig. 14.5 : Window Stay

## TYPICAL DETAILS OF MULTI-STAGE SHUTTERING

Sub Head : Repairs to Buildings  
Clause : 14.33



SUSPENDED FLOOR-MULTI STAGE SHUTTERING  
(VERTICAL SECTION)

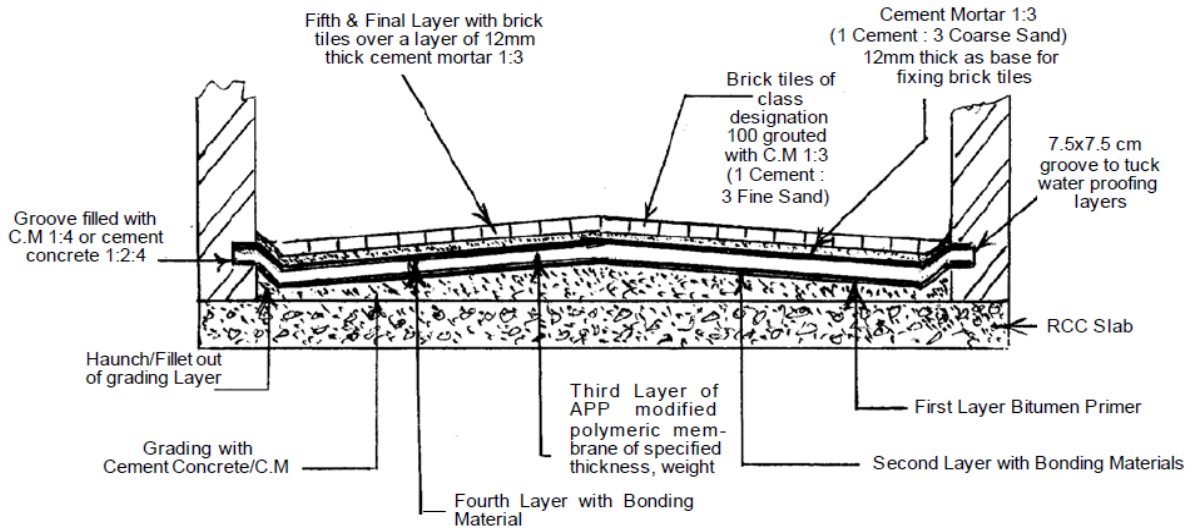


All Members are of Steel

Fig. 14.6 : Typical Details of Multi-Stage Shuttering

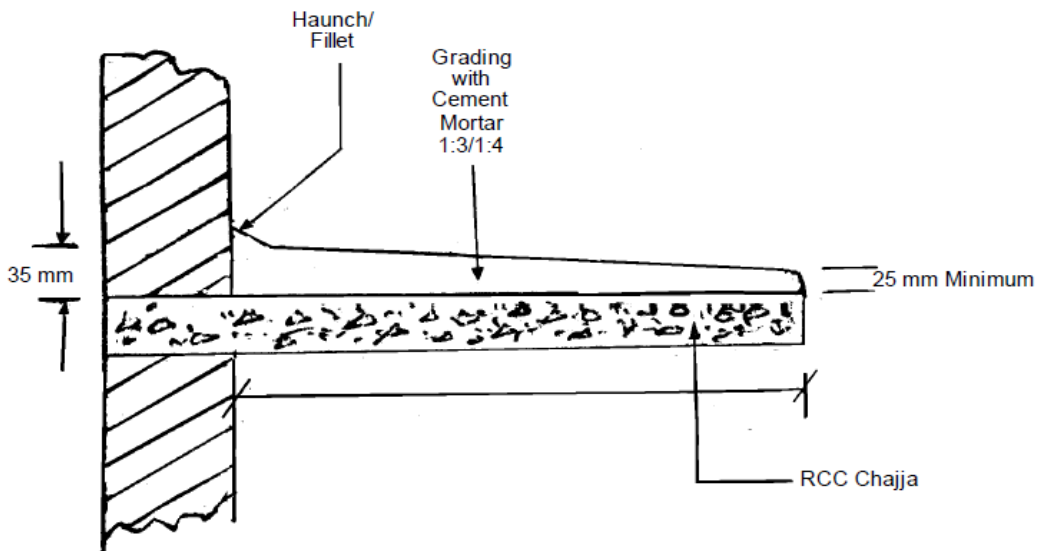


**Sub Head : Repairs to Buildings  
Clause : 14.49**



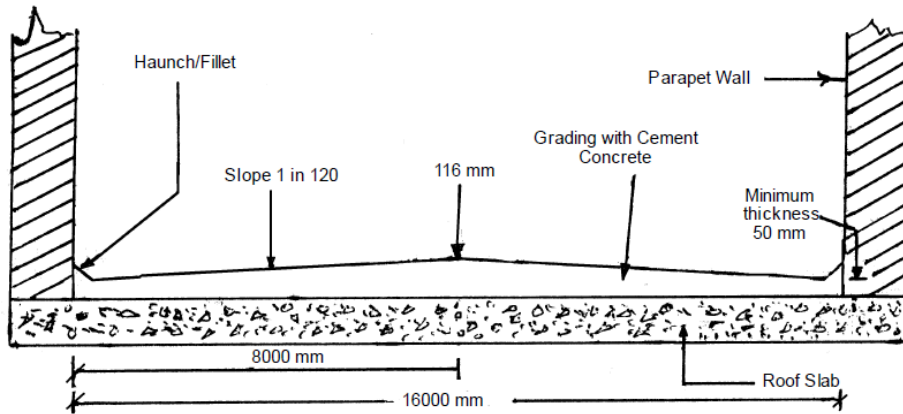
**Fig. 14.7 : Five Course Water Proofing Treatment with APP Modified Polymeric Membrane**

**Sub Head : Repairs to Buildings  
Clause : 14.49.1.7**



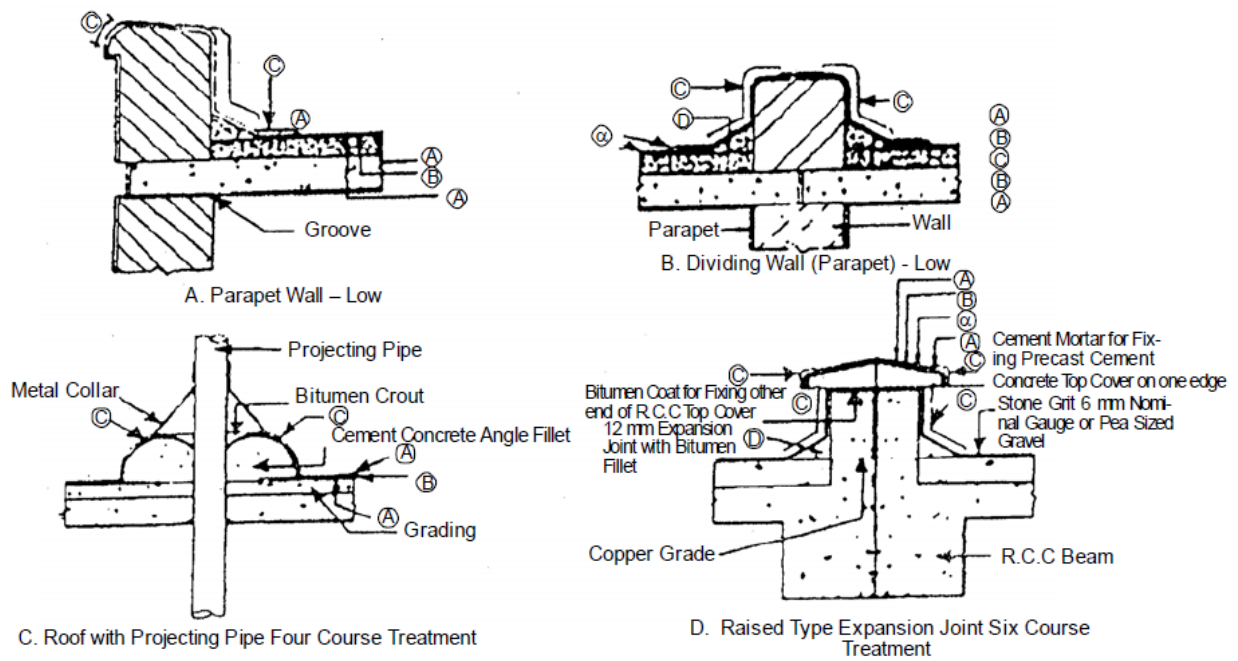
**Fig. 14.8 : Grading Chajja with Cement Mortar 1:3/1:4**

**Sub Head : Repairs to Buildings**  
**Clause : 14.49.1.7**



**Fig. 14.9 : Grading Roof Slab with Cement Concrete**

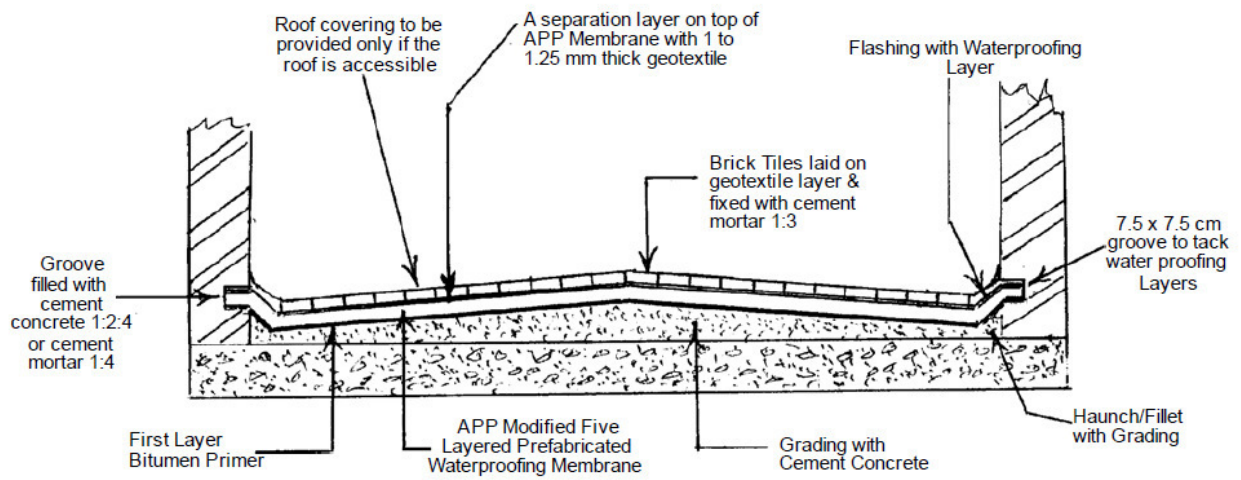
**Sub Head : Repairs to Buildings**  
**Clause : 14.49.1.7**



Diagrams Not to Scale  
 All dimensions are in mm

**Fig. 14.10 : Water Proofing**

**Sub Head : Repairs to Buildings**  
**Clause : 14.51**



**Fig. 14.11 : Five Layers Water-Proofing Treatment with APP Modified Prefabricated Membrane**



**SUB HEAD : 15.0**

**DISMANTLING AND DEMOLISHING**



## CONTENTS

| <i>Clause No.</i> | <i>Brief Description</i>   | <i>Page No.</i> |
|-------------------|--|-----------------|
|                   | List of Bureau of Indian Standards Codes   | 735             |
| 15.0              | Terminology  | 736             |
| 15.1              | General  | 736             |
| 15.2              | Recommendations for Demolition of Certain Special Types and Elements of Structures | 737             |
| 15.3              | Measurements   | 739             |
| 15.4              | Rates  | 741             |
| Fig. 15.1         | Demolition of Jack Arches  | 742             |
| Fig. 15.2         | Demolition of Masonry and Brickwork Arches   | 743             |
| Fig. 15.3         | Hand Demolition of In-Situ Concrete Structure                                      | 744             |





### LIST OF BUREAU OF INDIAN STANDARD CODES

| <i>S. No.</i> | <i>BIS. No.</i>      | <i>Subject</i>  |
|---------------|----------------------|---|
| 1.            | IS 1200 (Pt - XVIII) | Method of Measurements of Building and Civil Engineering Works (Part -XVIII) Demolition and Dismantling |
| 2.            | IS 4130              | Demolition of Buildings-  |

## 15.0 DISMANTLING AND DEMOLISHING

### 15.0 TERMINOLOGY

- (i) **Deconstruction** – Means a selective demolition in which salvage, reuse and recycling of demolished structure is maximized. The term ‘Dismantling’ implies carefully separating the parts without damage and removing. This may consist of dismantling one or more parts of the building as specified or shown on the drawings.
- (ii) **Demolition**: The term ‘Demolition’ implies breaking up. This shall consist of demolishing whole or part of work either manually or using mechanical force (various equipment) or by implosion using explosion, including all relevant items as specified or shown on the drawings.

### 15.1 GENERAL

This chapter relates to buildings only.

#### 15.1.1 Precautions

**15.1.1.1** All materials obtained from dismantling or demolition shall be the property of the Government unless otherwise specified and shall be kept in safe custody until they are handed over to the Engineer-in-Charge/ authorized representative.

**15.1.1.2** The demolition shall always be well planned before hand and shall generally be done in reverse order of the one in which the structure was constructed. The operations shall be got approved from the Engineer-in-Charge before starting the work.

Due care shall be taken to maintain the safety measures prescribed in IS 4130 and construction and demolition waste management rules 2016 shall be followed.

**15.1.1.3** Necessary propping, shoring and or under pinning shall be provided to ensure the safety of the adjoining work or property before dismantling and demolishing is taken up and the work shall be carried out in such a way that no damage is caused to the adjoining work or property. Wherever specified, temporary enclosures or partitions and necessary scaffolding with suitable double scaffolding and proper cloth covering shall also be provided, as directed by the Engineer-in-Charge. It shall be ensured that no dust is generated while demolishing. Demolition Rules – 2016 shall be followed.

**15.1.1.4** Necessary steps shall be taken to keep noise and dust nuisance to the minimum. All work needs to be done under the direction of Engineer-in-Charge. Helmets, goggles, safety belts etc., should be used whenever required and as directed by the Engineer-in-Charge. The demolition work shall be proceeded with in such a way that it causes the least damage and nuisance to the adjoining building and the public. Barricading shall be provided as per NGT guidelines.

**15.1.1.5** Dismantling shall be done in a systematic manner. All materials which are likely to be damaged by dropping from a height or by demolishing roofs, masonry etc. shall be carefully removed first. Chisels and cutters may be used carefully as directed. The dismantled articles shall be removed manually or otherwise, lowered to the ground (and not thrown) and then properly stacked as directed by the Engineer-in-Charge.

**15.1.1.6** Where existing fixing is done by nails, screws, bolts, rivets, etc., dismantling shall be done by taking out the fixing with proper tools and not by tearing or ripping off.

**15.1.1.7** Any serviceable material, obtained during dismantling or demolition, shall be separated out and stacked properly as directed by the Engineer-in-Charge within a lead of 50 meters. All unserviceable materials, rubbish etc. shall be disposed off at authorized locations by urban local bodies as directed by the Engineer-in-Charge.

**15.1.1.8** The contractor shall maintain/disconnect existing services, whether temporary or permanent, wherever required by the Engineer-in-Charge.

**15.1.1.9** No demolition work should be carried out at night especially when the building or structure to be demolished is in an inhabited area.

**15.1.1.10** Appropriate screens shall be placed where necessary to prevent injuries due to falling pieces.

**15.1.1.11** Water spray shall be used to reduce dust while tearing down plaster from brick work.

**15.1.1.12** Safety belts shall be used by labourers while working at higher level to prevent falling from the structure. Wherever, possible mechanized working platform shall be used.

**15.1.1.13** First-aid equipment shall be made available at all demolition works of any magnitude.

## **15.2 RECOMMENDATIONS FOR DEMOLITION OF CERTAIN SPECIAL TYPES AND ELEMENTS OF STRUCTURES**

**15.2.1** Roof Trusses If a building has a pitched roof, the roof structure should be removed to wall plate level by hand method. Sufficient purlins and bracing should be retained to ensure stability of the remaining roof trusses while each individual truss is removed progressively.

**15.2.1.1** Temporary bracing should be added, where necessary, to maintain stability. The end frame opposite to the end where dismantling is commenced, or a convenient intermediate frame should be independently and securely guyed in both directions before work starts.

**15.2.1.2** On no account should the bottom tie of roof trusses be cut until the principal rafters are prevented from making outward movement.

**15.2.3** Heavy Floor Beams Heavy bulks of timber and steel beams should be supported before cutting at the extremities and should then be lowered to a safe working place.

**15.2.4** Jack Arches Where tie rods are present between main supporting beams, these should not be cut until after the arch or series of arches in the floor have been removed. Particular care should be exercised and full examination of this type of structure undertaken before demolition is commenced (see Fig. 15.1). The floor should be demolished in strips parallel to the span of the arch. rings (at right angles to the main floor beams).

### **15.2.5 Brick Arches**

**15.2.5.1** Expert advice should be obtained and at all stages of the demolition, the closest supervision should be given by persons fully experienced and conversant in the type of work to ensure that the structure is stable at all times.

**15.2.5.2** As much dead load as possible may be removed provided it does not interfere with the stability of the main arch rings but it should be noted that the load-carrying capacity of many old arches relies on the filling between the spandrels. On no account should the restraining influence of the abutments be removed before the dead load of the spandrel fill and the arch rings are removed.

**15.2.5.3** The normal sequence of demolition is as shown in Fig. 15.2-A, namely:

- (a) Remove spandrel in filling down to the springing line,
- (b) Remove the arch. rings and
- (c) Remove the abutment.

**15.2.5.4** Special temporary support shall be provided in the case of skew bridges.

**15.2.5.5** A single span arch. can be demolished by hand by cutting narrow segments progressively from each springing parallel to the span of the arch until the width of the arch has been reduced to a minimum which can then be collapsed (see Fig. 15.2B).

**15.2.5.6** Where it is impossible to allow debris to fall to the ground below, centering designed to carry the load should be erected and the arch demolished progressively. The design of the centering should make appropriate allowance for impact.

**15.2.5.7** Where deliberate collapse is feasible the crown may be broken by the demolition ball method working progressively from edges to the centre (see Fig. 15.2C).

**15.2.5.8** Collapse of the structure can be effected in one action by the use of explosives. Charges should be inserted into boreholes drilled in both arch and abutments. This method is the most effective for demolition of tall viaducts.

**15.2.5.9** In multi-span arches before individual spans are removed, lateral restraint should be provided at the springing level. Demolition may then proceed as for a single span, care being taken to demolish the spandrels down to the springing line as the work proceeds (see Fig. 15.2D). Where explosives are used it is preferable to ensure the collapse of the whole structure in one operation to obviate the chance of leaving unstable portions standing.

#### **15.2.6 Cantilevers (Not part of a Framed Structure)**

A cantilever type of construction depends for its stability on the super imposed structure. Canopies, cornices, staircases and balconies should be demolished or supported before the tailing down load is removed.

#### **15.2.7 In-situ Reinforced Concrete**

**15.2.7.1** Before commencing demolition, the nature and condition of the concrete, the condition and position of reinforcement, and the possibility of lack of continuity of reinforcement should be ascertained.

**15.2.7.2** Attention should be paid to the principles of the structural design to determine which parts of the structure depend on each other to maintain overall stability.

**15.2.7.3** Demolition should be commenced by removing partitions and external non-load bearing cladding. It should be noted that in some buildings the frame may rely on the panel walls for stability.

**15.2.7.4** Where hard demolition methods are to be used, the following procedures should be used.

(a) Reinforced Concrete Beams

For beams, a supporting rope should be attached of preferably at two or three locations to the beam. Then the concrete should be removed from both ends by pneumatic drill and the reinforcement exposed. The reinforcement should then be cut in such a way as to allow the beam to be lowered under control to the floor (see Fig. 15.3A).

(b) Reinforced Concrete Columns

For columns, the reinforcement should be exposed at the base after restraining wire guy ropes have been placed round the member at the top. The reinforcement should then be cut in such a way as to allow the column to be pulled down to the floor under control. (see Fig. 15.3B for sequence of operations).

(c) Reinforced Concrete Walls Reinforced concrete walls should be cut into strips and demolished as for columns (Fig. 15.3C).

### **15.3 MEASUREMENTS**

**15.3.1** All work shall be measured net in the decimal system, as fixed in its place, subject to the following limits, unless otherwise stated hereinafter.

- (a) Dimensions shall be measured correct to a cm.
- (b) Areas shall be worked out in sqm correct to two places of decimal.
- (c) Cubical contents shall be worked out to the nearest 0.01 cum.

**15.3.2** Parts of work required to be dismantled and those required to be demolished shall be measured separately.

**15.3.3** Measurements of all work except hidden work shall be taken before demolition or dismantling and no allowance for increase in bulk shall be allowed.

**15.3.4** Specifications for deduction for voids, openings etc. shall be on the same basis as that adopted for new construction of the work.

**15.3.5** Work executed in the following conditions shall be measured separately.

- (a) Work in or under water and/or liquid mud
- (b) Work in or under foul position.

#### **15.3.6 Roofs**

- (i) Roof coverings generally including battens boarding, mats, bamboo jaffari or other subsidiary supports shall be measured in square metres except lead sheet roof covering which shall be measured in quintals (15.2.3) and stone slab roof covering which shall be measured in cubic metres.
- (ii) Ridges, hips and valleys shall be girthed and included with the roof area. Corrugated or semi corrugated surfaces shall be measured flat and not girthed.
- (iii) Mud phuska on roofs shall be measured in cubic metres.
- (iv) Lead sheets in roofs shall be measured in quintals and hips, valleys, flashings, lining to gutter etc. shall be included in this weight.
- (v) R.B. or R.C.C. roofs shall be measured as specified in 15.3.11.
- (vi) Supporting members, such as rafters, purlins, beams joists, trusses etc. of wood shall be measured in cubic metres and steel or iron sections, in quintals.

#### **15.3.7 Ceiling**

- (i) The stripping of ceilings shall be measured in square metres.
- (ii) Dismantling of supporting joists, beams, etc. shall be measured in cubic metres or in quintals as specified in 15.3.6(vi).
- (iii) Height above floor level, if it exceeds 3.5 m shall be paid for separately.

#### **15.3.8 Flooring and Pavings**

Dismantling of floors (except concrete and brick floors) shall be measured in square metres. Supports such as joints, beams etc. if any shall be measured as per 15.3.6(vi). Concrete and bricks paving shall be measured as per 15.3.9.

#### **15.3.9 Concrete and Brick Roofs and Suspended Floors**

Demolition of floors and roofs of concrete or brick shall be measured in cubic metres. Beams cantilevers or other subsidiary supports of similar materials, shall be included in the item. In measuring thickness of roofs provided with water proofing treatments with bitumen felts, the thickness of water proofing treatment shall be ignored.

#### **15.3.10 Walls and Piers**

- (i) Taking down walls and independent piers or columns of brick, stone or concrete shall be measured, in cubic metres. All copings, corbels, cornices and other projections shall be included with the wall measurements.
- (ii) In measuring thickness of plastered walls, the thickness of plaster shall be ignored.
- (iii) Ashlar face stones, dressed stone work, pre-cast concrete articles, etc. if required to be taken down intact shall be so stated and measured separately in cubic metres.
- (iv) Cleaning bricks stacking for measurements including all extra handling and removal and disposing off the rubbish as stated shall be enumerated in thousand of cleaned bricks.
- (v) Cleaning stone obtained from demolished/dismantling stone masonry of any description including ashlar facing dressed stone work, stone slabs or flagging and pre-cast concrete blocks including all extra handling and disposing off the rubbish as stated shall be measured in cubic meters of cleaned stone.
- (vi) Honey comb works or cavity walls of bricks stone or concrete shall be measured as solid.

#### **15.3.11 Reinforced Concrete and Brick Work**

Reinforced concrete structures and reinforced brick roofs and walls shall be measured in cubic meters and if reinforcement is required to be salvaged, it shall be so stated. Where reinforcement is required to be separated, scraped and cleaned, the work shall be measured separately in quintal of salvaged steel.

#### **15.3.12 Partitions, Trellis Work etc.**

Partitions or light walls, of lath and plaster, trellis work, expanded metal, thin concrete or terracotta slabs and other similar materials including frame work if any shall be measured in square meters stating the over all thickness.

#### **15.3.13 Wood Work**

All wood work including karries average 40 sq cm or over in section, shall be measured in cubic meters, while that under 40 sq cm in section, in running meters. Ballies shall be measured in running meters.

Boarding including wooden chajjas and sun shades along with supports shall be measured in square meters in its plane.

#### **15.3.14 Steel and Iron Work**

- (i) All steel and iron work shall be measured in quintals. The weight shall be computed from standard tables unless the actual weight can readily be determined.
- (ii) Riveted work, where rivets are required to be cut, shall be measured separately.
- (iii) Marking of structural steel required to be re-erected shall be measured separately.
- (iv) In framed steel items, the weight or any covering material or filling such as iron sheets and expanded metal shall be included in the weight of the main article unless such covering is not ordered to be taken out separately.

#### **15.3.15 Doors and Windows**

Dismantling of doors, windows, clerestory windows, ventilators etc. (wood or metal) whether done separately or along with removal of wall by making recess in the wall shall be enumerated. Those exceeding 3 sqm each in area shall be measured separately. The item shall include removal of chowkhats architraves, holdfasts and other attachments.

If only shutters are to be taken out it shall be measured separately.

#### **15.3.16 Pipes and Sewer Lines**

- (i) Water pipe lines including rain water pipes with clamps and specials, sewer lines (salt glazed ware or concrete) etc. shall be described by their diameter and length measured in running metres inclusive of joints.
- (ii) If the joints, special and fittings etc. are required to be separated, it shall be so stated and enumerated.
- (iii) Pucca drains shall be measured under relevant items.
- (iv) Valve cistern, public fountain platform, fire hydrants, etc. shall be enumerated.
- (v) Manholes and inspection chambers shall be enumerated stating the size and depth of manhole/inspection chamber. They shall be classified into different groups depending upon the depth, in unit of half and one metre depth. The depth of the manhole shall be the distance between the top of manhole cover and invert level of the drain.
- (vi) Ventilating shafts, gully traps, flushing cisterns and other appurtenant items of work shall be enumerated.

#### **15.3.17 Posts or Struts**

Posts or struts (wood, steel or RCC) section including taking out embedded portion shall be measured in running meters.

#### **15.3.18 Fencing Wire Mesh**

Wire mesh fencing of any type with frame shall be measured in square metres.

#### **15.3.19 Glazing**

Taking out any portion of serviceable glass except polished plate, from old sashes, skylights, etc. (any thickness, weight or size) raking out old putty, etc. shall be measured in square meters. Irregular circular panes shall be measured as rectangle or square enveloping the same. The width and height being measured correct to the nearest 0.5 cm.

#### **15.3.20 Road Work**

- (i) Different types of road surfaces shall be measured separately.
- (ii) Road surfaces metalling or soling (base) shall be measured in square meters.
- (iii) Concrete paving shall be measured as in 15.3.8 or 15.3.9 as the case may be.

#### **15.4 Rates**

The rate shall include the cost of all labour involved and tools used in demolishing and dismantling including scaffolding. The rate shall also include the charges for separating out and stacking the serviceable material properly and disposing off unserviceable material within a distance of 50 meters. The rate shall also include for temporary shoring for the safety of portions not required to be pulled down, or of adjoining property, and providing temporary enclosures or partitions, where considered necessary.



## DEMOLITION OF JACK ARCHES

Sub Head : Dismantling and Demolition  
Clause : 15.2.4

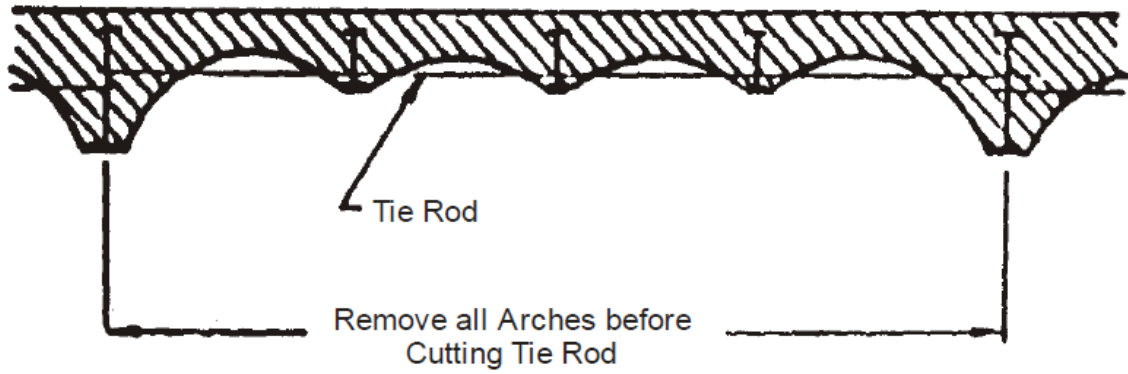


Fig. 15.1 : Demolition of Jack Arches

## DEMOLITION OF MASONRY AND BRICKWORK ARCHES

Sub Head : Dismantling and Demolition  
 Clause : 15.2.4 and 15.2.5

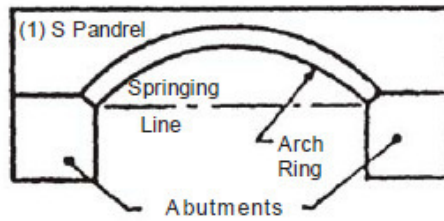


Fig. 15.2A

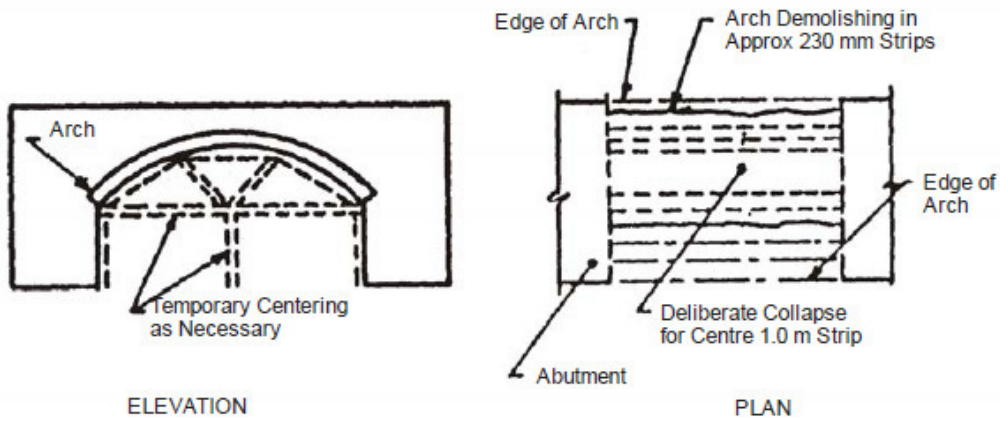


Fig. 15.2B

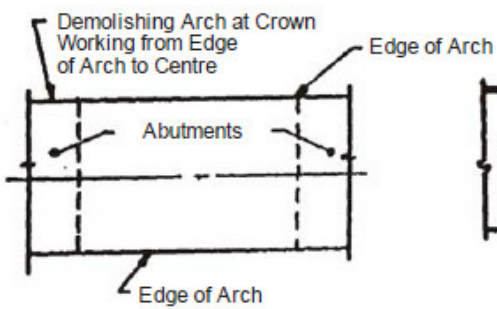


Fig. 15.2C

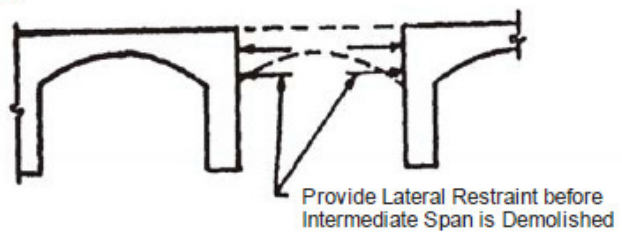


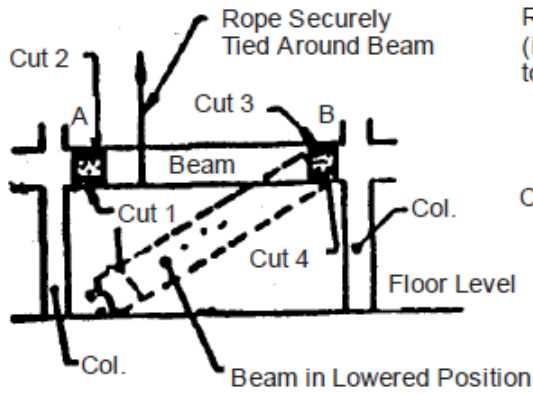
Fig. 15.2D

Note: Order of Demolition

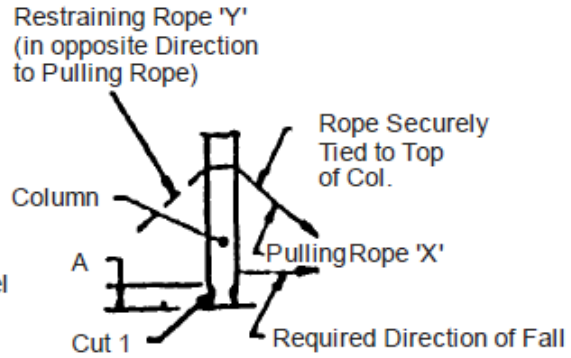
Fig. 15.2 : Demolition of Masonry and Brickwork Arches

# HAND DEMOLITION OF IN-SITU CONCRETE STRUCTURE

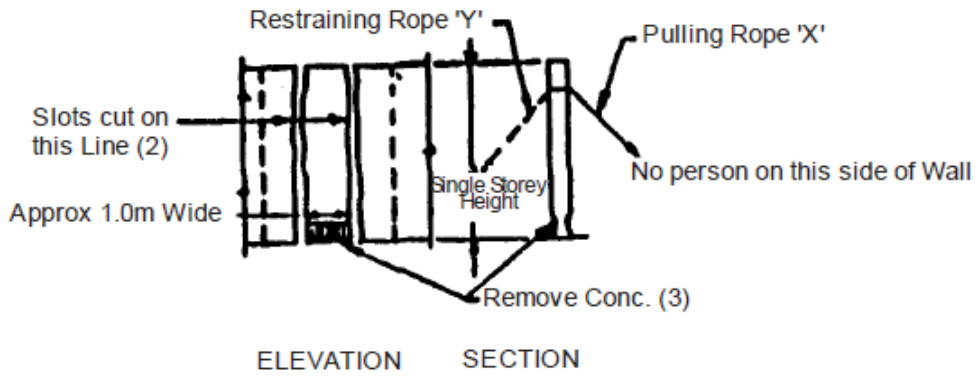
Sub Head : Dismantling and Demolition  
 Clause : 15.2.7.4



15.3A : R.C. Beams



15.3B : R.C. Columns



15.3C : R.C. Walls

Fig. 15.3 : Hand Demolition of In-Situ Concrete Structure

**SUB HEAD : 16.0**

**ROAD WORK**



## CONTENTS

| <i>Clause No.</i> | <i>Brief Description</i>   | <i>Page No.</i> |
|-------------------|--|-----------------|
|                   | List of Mandatory Tests  | 751             |
|                   | List of Bureau of Indian Standards Codes and IRC Standards                   | 757             |
| 16.0              | Terminology  | 760             |
| 16.1              | Materials  | 760             |
| 16.2              | Sub-Grade : Preparation and Consolidation                                    | 768             |
| 16.3              | Embankment Construction (Under Optimum Moisture Conditions)                  | 769             |
| 16.4              | Supplying and Stacking of Materials  | 770             |
| 16.5              | Earthwork in Road Construction   | 772             |
| 16.6              | Embankment Construction (without Optimum Moisture Conditions)                | 772             |
| 16.7              | Water Bound Macadam with Stone Aggregate                                     | 775             |
| 16.8              | Water Bound Macadam with Brick Aggregate (Overburnt (Jhama) Brick Aggregate) | 778             |
| 16.9              | Bajri Paths  | 779             |
| 16.10             | Brick Edging   | 779             |
| 16.11             | Scarifying Metalled (Water Bound) Surface                                    | 780             |
| 16.12             | Dry Stone Pitching   | 780             |
| 16.13             | Brick Pitching   | 781             |
| 16.14             | Cutting W.B.M. Roads and Making Good   | 782             |
| 16.15             | Cutting Bajri Paths and Making Good  | 782             |
| 16.16             | Fencing with G.I. Barbed Wire and RCC Posts                                  | 783             |
| 16.17             | G.I. Barbed Wire Fencing with Angle Iron Posts                               | 783             |

|       |   |     |
|-------|---|-----|
| 16.18 | Welded Steel Wire Fabric Fencing with RCC Posts   | 784 |
| 16.19 | Engraving Letters in Hard Stones  | 785 |
| 16.20 | Boundary Stones (Hard Stone)  | 785 |
| 16.21 | Precast RCC Boundary Stone  | 786 |
| 16.22 | Kilometers Stones (Fig. 16.7)   | 786 |
| 16.23 | Surface Dressing on New Surface with Hot Bitumen of grade VG- 10 One Coat   | 787 |
| 16.24 | Surface Dressing on New Surface Using Hot Bitumen of grade VG - 10 Two Coats  | 787 |
| 16.25 | Surface Dressing on Old Surface with Hot Bitumen of grade VG - 10 confirming to IS : 73 One Coat                              | 790 |
| 16.26 | Surface Dressing on New Surface with Bitumen Emulsion (minimum 50% bitumen content RS grade confirming to IS : 8887) One Coat | 790 |
| 16.27 | Surface Dressing on Old Surface with Bitumen Emulsion (minimum 50% bitumen content RS grade confirming to IS : 8887) One Coat | 791 |
| 16.28 | Tack Coat of Hot Straight Run Bitumen of grade VG- 10   | 791 |
| 16.29 | Tack Coat with Bitumen-Emulsion/ Hot bitumen of grade VG- 10  | 792 |
| 16.30 | Premix Carpet with Hot Bitumen of paving asphalt grade VG - 10 / VG-30  | 793 |
| 16.31 | Premix Carpet with Bitumen Emulsion   | 795 |
| 16.32 | Bituminous Penetration Macadam  | 796 |
| 16.33 | Bitumen Mastic Wearing Courses  | 799 |
| 16.34 | Bituminous Sheet with Hot Bitumen   | 805 |
| 16.35 | Seal Coat   | 806 |
| 16.36 | Cement Concrete Pavement (Under Ordinary Conditions)  | 808 |
| 16.37 | Cement Concrete Pavement Under Controlled Conditions  | 808 |
| 16.38 | Hard Crete  | 818 |

|       |   |     |
|-------|---|-----|
| 16.39 | Expansion Joint   | 818 |
| 16.40 | Construction Procedure                                      | 818 |
| 16.41 | Painting Road/ Runways Markings                             | 819 |
| 16.42 | Painting Road Surface (with Ready Mixed Road Marking Paint) | 820 |
| 16.43 | Lime Fly Ash Stabilised Soil Sub Base                       | 820 |
| 16.44 | Precast Lime Fly Ash Concrete Blocks                        | 822 |
| 16.45 | Concertina Coil Fencing                                     | 822 |
| 16.46 | Dense Graded Bituminous Macadam (DBM)                       | 823 |
| 16.47 | Bituminous Macadam  | 828 |
| 16.48 | Dense Bituminous Concrete                                   | 832 |
| 16.49 | Retro Reflective Sign Board                                 | 835 |
| 16.50 | Retro Reflective Overhead Signage                           | 838 |
| 16.51 | Road Markings Strips  | 840 |
| 16.52 | Kerb Channel of Cement Concrete                             | 842 |
| 16.53 | 75 mm Thick Compacted Bed of Dry Brick Ballast              | 842 |
| 16.54 | Post Delineators  | 843 |
| 16.55 | Excavating Holes upto 0.10 cum                              | 843 |
| 16.56 | Factory Made RCC Pavement Slab                              | 843 |
| 16.57 | Factory Made Cement Concrete Interlocking Paver Block       | 844 |
| 16.58 | Kerb Stone (Precast)  | 844 |
| 16.59 | G.I. Chain Link Fabric Fencing                              | 844 |
| 16.60 | Supplying and Stacking of Hard Stone (for Stone Pitching)   | 845 |



|            |  |     |
|------------|--|-----|
| 16.61      | Vacuum Dewatered Cement Concrete Pavement  | 845 |
| 16.62      | Granular Sub-Base  | 845 |
| 16.63      | Wet Mix Macadam (WMM) Sub-Base/Base  | 847 |
| 16.64      | Reflective Pavement Markers (RPM) or Road Studs  | 851 |
| 16.65      | Prime coat over granular base  | 853 |
| Appendix A | Bitumen Register   | 855 |
| Appendix B | Determination of In-Situ Density of Asphaltic Carpet or Bituminous Macadam by Sand Pouring Device          | 856 |
| Appendix C | List of Minimum Equipment to be Provided in the Field Testing Laboratory by the Contractor at his own Cost | 857 |
| Appendix D | General Guidelines Issued by NDMC  | 858 |
| Fig. 16.1  | Provision for Lateral Confinement of Aggregates  | 862 |
| Fig. 16.2  | R.C.C. Name Board without Post   | 863 |
| Fig. 16.3  | Sign/Name Board  | 864 |
| Fig. 16.4  | Boundary Stone   | 865 |
| Fig. 16.5  | Standard Numerals  | 866 |
| Fig. 16.6  | Standard Letters   | 867 |
| Fig. 16.7  | Kilometre Stones Type Design   | 868 |
| Fig. 16.7A | Kilometre Stones Location (For Highways)   | 869 |
| Fig. 16.8  | Informatory Sign Board   | 870 |
| Fig. 16.9  | Barbed Wire Fencing (with RCC Post)  | 871 |
| Fig. 16.10 | Fencing with R.C.C. Post Rails, Pales  | 872 |
| Fig. 16.11 | Location of Informatory Sign Boards  | 873 |
| Fig. 16.12 | Kerb & Channel Stones  | 874 |
| Fig. 16.13 | Broad Details of Cooker for Bitumen Mastic in Wearing Courses  | 875 |

### LIST OF MANDATORY TESTS

| Material/<br>work                                | Clause /<br>Para No.                           | Test  | Field/<br>Laboratory                       | Test<br>Procedure            | Frequency of Testing   |  |
|--|--|---|--|------------------------------|--|--|
| 1) Coarse<br>Aggregate                           | 16.1.1   | Los Angeles Abrasion<br>Value or<br>Aggregate Impact Value      | Laboratory                                 | IS 2386<br>(Part 4)          | Per 200 m <sup>3</sup>   |  |
|  |  | Specific gravity, Water<br>absorption & Density                 | Laboratory                                 | IS 2386<br>(Part 3)          |  |  |
|  | 16.1.1<br>Table 16.2                           | Combined Flakiness<br>and<br>Elongation Indices                 | Field                                      | IS 2386<br>(Part 1)          | Per 100 m <sup>3</sup>   |  |
|  |  | Size and grading of<br>aggregate                                | Field                                      | IS 2386<br>(Part 1)          | Per 100 m <sup>3</sup>   |  |
| 2) Fine<br>Aggregate                             | 16.1.2   | Deleterious materials   | Field                                      | IS 2386<br>(Part 2)          | As required by the Engineer-in-<br>Charge.   |  |
|  |  | Specific gravity, Water<br>absorption & Density                 | Laboratory                                 | IS 2386<br>(Part 3)          |  |  |
|  |  | Size and grading of<br>aggregate                                | Field                                      | IS 2386<br>(Part 1)          |  |  |
| 3) Bitumen                                       | 16.1.5   | As prescribed in IS 73 or<br>IRC:SP:53, IS:15462                | Laboratory                                 | As<br>prescribed<br>in IS 73 | As required by the Engineer-in-<br>Charge.   |  |
| 4) Embankment<br>under<br>(O.M.C.<br>conditions) | 16.3.1   | (a) Moisture content  | Laboratory                                 | IS 2720<br>(Part 2)          | 250 m <sup>3</sup>   |  |
|  |  | (b) Density   | Field                                      | IS 2720<br>(Part 28)         | 250 m <sup>3</sup>   |  |
|  | 16.3.4.4                                       | c) Control test on borrow<br>pits.                              |  |                              |  |  |
|  |  | (i) Gradation   | Laboratory                                 | IS 2720<br>(Part 4)          | One to two tests per 8000 m <sup>3</sup>   |  |
|  |  | (ii) Plasticity   | Laboratory                                 | IS 2720<br>(Part 5)          | -do-   |  |
|  |  | (iii) Proctor Test  | Laboratory                                 | IS 2720<br>(Part 8)          | -do-   |  |
|  |  | (iv) Deleterious content  | Laboratory                                 | IS 2386<br>(Part 2)          | As required by the Engineer-in-<br>Charge  |  |
|  |  | (v) Moisture contents   | Laboratory                                 | IS 2720<br>(Part 2)          | 250 m <sup>3</sup>   |  |
|  | 5) Prime<br>Coat / Tack<br>Coat / Fog<br>Spray |   | (i) Quality of Binder                      | Laboratory                   | IS:73  | Number of samples per lot and<br>tests as per IS:73, IS:217 and<br>IS:8887 as applicable |
|  |  |   | (ii) Binder temperature<br>for application | Field                        |  | At regular close intervals   |
|  |  | (iii) Rate of spread of<br>Binder                               | Field                                      |                              | Three tests per day  |  |
| 6) Seal Coat<br>/ Surface<br>Dressing            |  | (i) Quality of binder   | Laboratory                                 | IS:73                        | Same as mentioned under Serial<br>No. 5  |  |
|  |  | (ii) Aggregate Impact<br>Value or Los Angeles<br>Abrasion Value | Laboratory                                 | IS:2386<br>(Part 4)          | One test per 200 cu.m of each<br>source and whenever there is<br>change in the quality of<br>aggregate               |  |
|  |  | (iii) Combined Flakiness<br>Index and Elongation<br>Indices     | Field                                      | IS:2386<br>(Part 1)          | One test per 100 cu.m of<br>aggregate for each source and<br>whenever there is change in the<br>quality of aggregate |  |
|  |  | (iv) Stripping value of<br>aggregates (Immersion<br>Tray Test)  | Laboratory                                 | IS:6241                      | One test of each source and<br>whenever there is change in the<br>quality of aggregate                               |  |

|   |               |   |                     |                  |   |
|---|---------------|---|---------------------|------------------|---|
|   |               | (v) Water absorption of aggregates  | Laboratory          | IS:2386 (Part 3) | -- do --  |
|   |               | (vi) Grading of aggregates  | Field               | IS:2386 (Part 1) | Two tests per day   |
|   |               | (vii) Soundness test (Magnesium and Sodium Sulphate)  | Laboratory          | IS:2386 (Part 5) | One test for each source and whenever there is change in the quality of aggregate                           |
|   |               | (viii) Temperature of binder in boiler, aggregate in dryer and mix at the time of laying and compaction     | Field               |                  | At regular intervals  |
|   |               | (ix) Rate of spread of materials  | Field               |                  | Same as mentioned under Serial No. 5  |
|   |               | (x) Percentage of fractured faces (When gravel is used)   | Field               |                  | One test per 100 cu.m of aggregate  |
| 7) Bitumen Macadam                                | 16.32 & 16.47 | (i) Quality of binder   | Field               | IS 73            | Same as mentioned under Serial No. 5  |
|   |               | (ii) Aggregate Impact Value/ Los Angeles Abrasion Value   | Laboratory          | IS 2386 (Part 4) | Same as mentioned under Serial No. 6  |
|   |               | (iii) Combined Flakiness Index and Elongation Indices   | Laboratory          | IS 2386 (Part 1) | One test per 350 cu.m for each source   |
|   |               | (iv) Stripping value of aggregates  | Laboratory          | IS 6241          | Same as mentioned under Serial No. 6  |
|   |               | (v) Water absorption of aggregates  | Field or Laboratory | IS 2386 (Part 3) | Same as mentioned under Serial No. 6  |
|   |               | (vi) Deleterious material   | Field               | IS:2386 (Part 2) | Once in the month   |
|   |               | (vii) Grading of aggregates   | Field               | IS 2386 (Part 1) | Same as mentioned under Serial No. 6  |
|   |               | (viii) Soundness test (Magnesium and Sodium Sulphate)   | Laboratory          | IS:2386 (Part 5) | Same as mentioned under Serial No. 6  |
|   |               | (ix) Binder content   | Laboratory          |                  | Two test per day per plant  |
|   |               | (x) Control of temperature of binder and aggregate for mix and of the mix at the time of laying and rolling | Field               |                  | Same as mentioned under Serial No. 6  |
|   |               | (xi) Density of Comp layer  | Laboratory          | IS 2386 (Part 3) | One test per 700 sq.m area  |
|   |               | (xii) Rate of spread of Mixed materials   | Field               |                  | At regular intervals.   |
| 8) Dense Bituminous Macadam / Bituminous Concrete |               | (i) Quality of binder   | Laboratory          | IS:73            | Number of samples per lot and tests as per IS:73 or IRC:SP:53, IS:15462                                     |
|   |               | (ii) Aggregate Impact Value / Los Angeles Abrasion Value  | Laboratory          | IS:2386 (Part 4) | One test per 350 cu.m of aggregate for each sour and whenever there is change in the quality of aggregate   |
|   |               | (iii) Flakiness and Elongation Indices  | Laboratory          | IS:2386 (Part 1) | One test per 350 cu.m of aggregate for each source and whenever there is change in the quality of aggregate |
|   |               | (iv) Soundness test (Sodium or Magnesium Sulphate test)   | Laboratory          | IS:2386 (Part 5) | One test for each source and whenever there is change in the quality of aggregate                           |
|   |               | (v) Water absorption of aggregates  | Laboratory          | IS:2386 (Part 3) | One test for each source and whenever there is change in the quality of aggregate                           |

|                                    |  |   |            |                  |  |
|------------------------------------|--|---|------------|------------------|--|
|                                    |  | (vi) Plasticity Index   | Laboratory | IS:2386 (Part 5) | One test for each source and whenever there is change in the quality of aggregate  |
|                                    |  | (vii) Mix grading   | Laboratory |                  | One set for individual constituent and mixed aggregate from dryer for each 400 tonnes of mix subject to minimum of two tests per day per plant |
|                                    |  | (viii) Stability and voids analysis of mix including theoretical maximum specific of loose mix                    | Laboratory |                  | Three tests for stability, flow value, density and void contents for each 400 tonnes of mix subject to minimum of two tests per day per plant. |
|                                    |  | (ix) Moisture Susceptibility of mix (AASHTO T283)   | Laboratory |                  | One test for each mix type whenever there is change in the quality or source of coarse or fine aggregate                                       |
|                                    |  | (x) Temperature of binder in boiler, aggregate in dryer and mix at the time of laying and compaction              | Field      |                  | At regular intervals   |
|                                    |  | (xii) Binder content  | Laboratory |                  | One set for each 400 tonnes of mix subject to minimum of two tests per day per plant   |
|                                    |  | (xii) Rate of spread of mix material  | Field      |                  | After every 5 <sup>th</sup> truck load   |
|                                    |  | (xiii) Density of compacted layer   | Laboratory |                  | One test per 700 sq.m area   |
| 9) Slurry seal and Micro surfacing |  | (i) Quality of aggregate sand equivalent value water absorption soundness test (Sodium / Magnesium Sulphate Test) | Laboratory |                  | One per source / site  |
|                                    |  | (ii) Quality of Emulsion  | Laboratory |                  | One per lot of 20 t as per IS:8887   |
|                                    |  | (iii) Aggregate Moisture  | Laboratory |                  | Two per day  |
|                                    |  | (iv) Aggregate Gradation  | Field      | IS:2386 (Part 1) | Two per day at site  |
|                                    |  | (v) Binder Content  | Laboratory |                  | Two per lane per Km  |
|                                    |  | (vi) Calibration of Machine   | Laboratory |                  | Once per Project   |
|                                    |  | (vii) Quantity of Slurry (By weight of aggregate)   | Field      |                  | Daily (Travel time of Machine)   |
| 10) Mastic asphalt                 |  | (i) Quality of binder   | Laboratory |                  | Same as mentioned under serial No. 8   |
|                                    |  | (ii) Aggregate Impact Value or Los Angeles Abrasion Value   | Laboratory | IS:2386 (Part 4) | Same as mentioned under serial No. 8   |
|                                    |  | (iii) Combined Flakiness and Elongation Indices   | Field      | IS:2386 (Part 1) | Same as mentioned under serial No. 8   |
|                                    |  | (iv) Stripping value  | Laboratory | IS:6241          | Same as mentioned under serial No. 6   |
|                                    |  | (v) Deleterious material  | Field      | IS:2386 (Part 2) | One in a month   |
|                                    |  | (vi) Grading of aggregates  | Field      | IS:2386 (Part 1) | Two tests per day per plant on the individual constituent and mixed aggregates from the dryer  |
|                                    |  | (vii) Water absorption of aggregates  | Laboratory | IS:2386 (Part 3) | Same as mentioned under serial No. 8   |
|                                    |  | (viii) Soundness test (Magnesium Sulphate / Sodium Sulphate)  | Laboratory | IS:2386 (Part 5) | Same as mentioned under serial No. 8   |

|  |  |  |            |                  |   |
|--|--|--|------------|------------------|---|
|  |  | (ix) Binder content  | Laboratory |                  | Two test per day per plant  |
|  |  | (x) Control of temperature of binder and aggregate for mixing and of the mix at the time of laying and rolling | Field      |                  | At regular close intervals  |
|  |  | (xi) Rate of Spread of Mixed Material  | Field      |                  | Regular control through check of layer thickness                            |
|  |  | (xii) Hardness number  | Laboratory |                  | Minimum two tests per day   |
| 11) Recycled Material                      |  | Grading of aggregate   | Field      | IS:2386 (Part 1) | Two tests per day   |
| 12) Cold Mixes                             |  |  | Laboratory |                  | All tests as per S. No. 8   |
| 13) Quality of Modified Binder             |  |  | Laboratory |                  | Number of samples per lot and tests as per IS:15462                         |
| 14) Geo textiles                           |  |  | Laboratory |                  | The requirements of Section 700 of MORTH Specification shall apply          |
| 15) Granular Sub Base (GSB)                |  | (i) Gradation  | Field      | IS:2386 (Part 1) | One test per 400 cu.m.  |
|  |  | (ii) Atterberg limits  | Laboratory | IS:2720 (Part 5) | One test per 400 cu.m.  |
|  |  | (iii) Water absorption   | Laboratory |                  | One test per 400 cu.m.  |
|  |  | (iv) Density of compacted layer  | Laboratory |                  | One test per 1000 cu.m.   |
|  |  | (v) Deleterious constituents   | Field      | IS:2386 (Part 2) | As required   |
|  |  | (vi) Soundness test  | Field      | IS:2386 (Part 5) | Same as mentioned under serial No. 8  |
|  |  | (vii) CBR  | Laboratory |                  | As required   |
| 16) Lime / Cement Stabilised Soil Sub-base |  | (i) Quality of lime / Cement   | Laboratory |                  | One test for each consignment subject to a minimum of one test per 5 tonnes |
|  |  | (ii) Lime / Cement content   | Laboratory |                  | Regularly, through procedural checks  |
|  |  | (iii) Degree of pulverization  | Laboratory |                  | Periodically as considered necessary  |
|  |  | (iv) CBR or Unconfined Compressive Strength Test on a set of 3 specimens                                       | Laboratory |                  | As required   |
|  |  | (v) Moisture content prior to compaction   | Laboratory |                  | One set of two tests per 500 sq.m.  |
|  |  | (vi) Density of compacted layer  | Laboratory |                  | One set of two tests per 500 sq.m.  |
|  |  | (vii) Deleterious constituents   | Field      |                  | As required   |
| 17) Water Bound Macadam                    |  | (i) Aggregate Impact Value   | Laboratory | IS:2386 (Part 4) | One tests per 1000 cu.m of aggregate  |
|  |  | (ii) Grading of aggregate  | Field      | IS:2386 (Part 1) | One test per 250 cu.m   |
|  |  | (iii) Combined Flakiness and Elongation Indices  | Laboratory | IS:2386 (Part 1) | One tests per 500 cu.m of aggregate   |
|  |  | (iv) Atterberg limits of binding material  | Laboratory | IS:2386 (Part 4) | One test per 50 cu.m of binding material                                    |
|  |  | (v) Atterberg limits of screenings   | Laboratory | IS:2720 (Part 5) | One tests per 100 cu.m of aggregate   |
|  |  | (vi) Water absorption of aggregate   | Laboratory | IS:2386 (Part 3) | Once in a month   |
|  |  | (vii) Deleterious material   | Field      | IS:2386 (Part 2) | As required, once in a month  |

|  |          |  |            |                                   |   |
|--|----------|--|------------|-----------------------------------|---|
| 18) Wet Mix Macadam                                      |          | (i) Aggregate Impact Value or Los Angeles Abrasion value               | Laboratory | IS:2386 (Part 4)                  | One tests per 1000 cu.m of aggregate  |
|  |          | (ii) Grading of aggregate  | Field      | IS:2386 (Part 1)                  | One tests per 200 cu.m of aggregate   |
|  |          | (iii) Combined Flakiness and Elongation Indices                        | Laboratory | IS:2386 (Part 1)                  | One tests per 500 cu.m of aggregate   |
|  |          | (iv) Atterberg limits of portion of aggregate passing 425 micron sieve | Laboratory | IS:2720 (Part 5)                  | One tests per 200 cu.m of aggregate   |
|  |          | (v) Density of compacted layer   | Field      |                                   | One set of three tests per 1000 sq.m.   |
|  |          | (vi) Water absorption of aggregate                                     | Laboratory | IS:2386 (Part 3)                  | Once in a month   |
|  |          | (vii) Deleterious material   | Field      | IS:2386 (Part 2)                  | As required, once in a month  |
| 19) Cement concrete pavement under controlled conditions | 16.37.19 | Coarse aggregate<br>1. Flakiness Index                                 | Laboratory | IS 2386 (Part 1)                  | Before approval of the quarry and every subsequent change in the source of supply and one test per 100 cum. |
|  |          | 2. Impact Value  | -do-       | IS 2386 (Part 4)                  | -do-  |
|  |          | 3. Loss Angles abrasion Value  | -do-       | -do-                              | -do-  |
|  |          | 4. Deleterious material  | -do-       | IS 2386 (Part 2)                  | Before approval of the quarry and at every subsequent change in the source of supply                        |
|  |          | 5. Moisture content  | -do-       | IS 2386 (Part 3)                  | Regularly as required subject to a minimum of one test per day  |
|  |          | <b>Fine Aggregate</b>  |            |                                   |   |
|  |          | 1. Silt content  | Field      | As per CPWD specification Vol. I. | One test per 15 cum.  |
|  |          | 2. Gradation of sand   | -do-       | IS 2386 (Part 2)                  | -do-  |
|  |          | 3. Deleterious material  | -do-       | IS 2386 (Part 2)                  | Before approval of the quarry and at every subsequent change in the source of supply                        |
|  |          | 4. Moisture content  | -do-       | IS 2386 (Part 3)                  | Regularly as required subject to a minimum of two tests per day   |
|  |          | 5. Mix Aggregate   | Field      | IS 2386 (Part 1)                  | One test per 15 cum of concrete   |
|  |          | 6. Flexural strength   | Laboratory | IS 526                            | One test consisting of 8 specimen for 30 cum. of concrete   |



## LIST OF BUREAU OF INDIAN STANDARDS CODES AND IRC STANDARDS

| <i>S. No.</i> | <i>BIS. No.</i>      | <i>Subject</i>   |
|---------------|----------------------|--|
| 1.            | IS 73                | Specification for paving bitumen   |
| 2.            | IS 164               | Ready mixed paint for road marking   |
| 3.            | IS 217               | Specification for cut back bitumen   |
| 4.            | IS 8112              | Specification for 43 grade ordinary Portland Cement  |
| 5.            | IS 278               | Specification for galvanized steel barbed wire for fencing   |
| 6.            | IS 334               | Glossary of terms relating to bitumen and tar  |
| 7.            | IS 383               | Specification for coarse and fine aggregate from natural sources for concrete  |
| 8.            | IS 460               | Specification for test sieves  |
| 9.            | IS 516               | Method of test for strength of concrete  |
| 10.           | IS 702               | Specification for industrial bitumen   |
| 11.           | IS 712               | Specification for building limes   |
| 12.           | IS 1195              | Specification for bitumen mastic for flooring  |
| 13.           | IS 1199              | Methods of sampling and analysis of concrete   |
| 14.           | IS 1203              | Method of testing tar and bituminous material, determination of penetration  |
| 15.           | IS 1205              | Method of testing tar and bituminous material determination of softening point   |
| 16.           | IS 1208              | Method of testing tar and bituminous material determination of ductility   |
| 17.           | IS 1212              | Method of testing tar and bituminous material determination of loss of heating   |
| 18.           | IS 1216              | Method of testing tar and bituminous material determination of solubility in carbon-di-sulphide, trichloroethylene   |
| 19.           | IS 1834              | Specification for hot applied sealing compound for joint in concrete   |
| 20.           | IS 1838 (Pt. 1)      | Specification for performed fillers for expansion joint in concrete pavements and structures (non extruding and resilient type/ bitumen impregnated fibre) |
| 21.           | IS 2386 (Pt. 1)      | Method of test for aggregate for concrete particle size and shape  |
| 22.           | IS 2386 (Pt. 2) 1963 | Method of test for aggregate for concrete estimation of deleterious materials and organic impurities   |
| 23.           | IS 2386 (Pt. 3)      | Method of test for aggregate for concrete specific gravity, density, voids, absorption and bulking   |
| 24.           | IS 2386 (Pt. 4)      | Method of test for aggregate for concrete mechanical properties  |



|     |                      |  |
|-----|----------------------|--|
| 25. | IS 2720 (Pt.V)       | Method of test for soil: Determination of liquid and plastic limit.  |
| 26. | IS 2720 (Pt. VII)    | Methods of test for soils: part VII determination of water content dry density relation using light compaction |
| 27. | IS 2720 (Pt. XXVIII) | Method of test for soil: determination of dry density of soils in place, by sand replacement method            |
| 28. | IS 3812              | Specification for fly ash for use as pozzolana and admixture   |
| 29. | IS 5317              | Specification for bitumen mastic for bridges decking and roads   |
| 30. | IS 5640              | Method of test for determining aggregate impact value of soft coarse aggregates                                |
| 31. | IS 6241              | Method of test for determination of stripping value of road aggregates   |

**IRC STANDARDS:**

|    |         |  |
|----|---------|--|
| 1. | IRC 10  | Recommended practice for borrow pits for road embankments constructed by manual operation    |
| 2. | IRC 29  | Specification for bituminous concrete for road pavements                                     |
| 3. | IRC 36  | Recommended practice for construction of earth embankments for road works                    |
| 4. | IRC 60  | Tentative guidelines for the use of lime flyash concrete as pavement base of sub base        |
| 5. | IRC 88  | Recommended practice for lime flyash stabilized soil base/ sub base in pavement construction |
| 6. | IRC 107 | Tentative specification for bitumen mastic wearing courses                                   |

## 16.0 ROAD WORK

### 16.0 TERMINOLOGY

**Asphalt** : A natural or artificial mixture in which bitumen is associated with mineral matter. The word 'Asphalt' should always be qualified by indication of its origin or nature.

**Asphalt Mastic** : An intimate mixture of mineral fillers, well graded sand and/or stone chippings with a hard grade of bitumen, cooked and laid hot manually by means of wooden float. The mixture settles to a coherent, void less and impermeable solid or semi-solid mass under normal temperature condition.

**Binder**: The binder shall be an appropriate type of bituminous materials complying with the relevant Indian Standard (IS) as defined in the appropriate clauses of these specifications or as otherwise specified herein. The choice of binder shall be stipulated in the contract or by the Engineer-in-charge.

**Bitumen**: A black or dark brown non crystalline solid or viscous material, having adhesive properties derived from petroleum either by natural or refinery processes and substantially soluble in carbon disulphide.

Bitumen shall be paving bitumen of viscosity grade complying with Indian Standard Specifications for "Paving bitumen" IS:73:2006 of grade appropriate for the traffic and climatic conditions of the Project Highway. The heavily trafficked roads in hot areas may find harder grade bitumen more appropriate while pavements in mountainous regions subject to sub-zero temperatures during winter months carrying relatively lower traffic loads subject to the phenomenon of "Frost Heave" may find less viscous bitumen resistant to fatigue and cold cracking more appropriate.

**Bitumen-Cutback** : Bitumen, the viscosity of which has been reduced by a volatile diluent when blended with kerosene or naphtha type diluent or fuel oil, is called, medium or rapid or slow curing cut backs respectively.

**Bitumen-Emulsion** : A liquid product in which a substantial amount of bitumen is suspended in a finely divided condition in an aqueous medium containing an emulsifier and stabiliser. The emulsion is termed 'Anionic' when the bitumen particles are negatively charged and the aqueous phase is alkaline. The emulsion is termed 'cationic' when the particles are positively charged and the aqueous phase is acidic.

**Bitumen Mastic Filler** : Inorganic mineral material all of which will pass through specified IS sieve used in admixture with solid or semi-solid bituminous material.

**Road tar** : A product obtained by treating at high temperature coal tar in such a manner that it conforms to a specification which defines its suitability for road construction.

**Tar** : A viscous material having adhesive properties and resulting from the distinctive distillation of certain type of organic material. The term Tar should be preceded by the name of the material from which it is produced e.g. coal, shale, peat, vegetable matter and its mode of production shall be indicated.

**Flash point** : The lowest temperature at which the vapour of a substance can be ignited in air by a flame under specified conditions of test. The substance itself does not continue to burn.

**Tack Coat** : It shall consist of application of a single coat of low viscosity liquid bituminous material to an existing road surface preparatory to further bituminous construction.

**Bitumen concrete (Asphaltic concrete)** : A well graded mixture of high quality aggregates with designated proportion of bitumen, hot mixed, hot laid and hot rolled into a uniform dense mass with specified design criteria.

**Ductility** : The property by which a material can be drawn out without breaking, for bitumen it is measured by the distance in centimetres to which it will elongate before breaking, when two ends of a briquette specimen of the material of the specified form and cross-section are pulled apart under water at a specified speed and temperature.

**Viscosity** : The property of a liquid by which it resists flow due to internal friction and is measured by the ratio of the shearing stress to the rate of shear.

### 16.1 MATERIALS

#### 16.1.1 Aggregate Coarse

Coarse aggregate as specified in the item shall be either crushed/broken stone, crushed slag, over burnt (Jhama) brick aggregate or one of the naturally occurring aggregates such as kanker or laterite of suitable quality as stated hereinafter and approved by the Engineer-in-Charge.

The stone aggregate shall conform to the physical requirements set forth in Table 16.1. The type and size range of the aggregate shall be specified in the contract.

If the water absorption value of the coarse aggregate is greater than 2 percent, the soundness test shall be carried out on the material delivered to site as per IS:2386 (Part-5).

**TABLE 16.1**  
**Physical Requirements of Coarse Aggregate for Water Bound Macadam for Sub-Base / Base Courses**

| S. No | Test   | Test method   | Requirements             |
|-------|--|---|--------------------------|
| 1.*** | Los Angeles Abrasion value<br>or<br>Aggregate impact value | IS 2386 (Part-4)<br>IS 2386 (Part-4) or<br>IS 5640* | 40% (Max.)<br>30% (Max.) |
| 2.    | Combined flakiness and<br>Elongation Indices (Total)**     | IS 2386 (Part-1)                                    | 35% (Max.)               |

\* Aggregates which get softened in presence of water shall be tested for impact value under wet conditions in accordance with IS:5640.

\*\* The requirements of flakiness index and elongation index shall be enforced only in case of crushed/broken stone and crushed slag.

\*\*\* In case water bound macadam is used for sub-base, the requirements in respect of Los Angeles Value and Aggregate Impact Value shall be relaxed to 50 percent and 40 percent maximum respectively.

The coarse aggregate shall conform to one of the gradings given in Table 16.2 as specified. For crushable type of aggregates such as brick metal, kankar and laterite, grading shall not be regarded as very important, but the material should generally be within the specified range.

**TABLE 16.2**  
**Grading Requirements of Coarse Aggregate for W.B.M.**

| Grading No. | Size Range       | IS Sieve Designation | Percent by weight passing the sieve |
|-------------|------------------|----------------------|-------------------------------------|
| 1           | 90 mm to 45 mm   | 125 mm               | 100                                 |
|             |                  | 90 mm                | 90 – 100                            |
|             |                  | 63 mm                | 25 – 60                             |
|             |                  | 45 mm                | 0 – 15                              |
|             |                  | 22.4 mm              | 0 – 5                               |
| 2           | 63 mm to 45 mm   | 90 mm                | 100                                 |
|             |                  | 63 mm                | 90 – 100                            |
|             |                  | 53 mm                | 25 - 75                             |
|             |                  | 45 mm                | 0 – 15                              |
|             |                  | 22.4 mm              | 0 – 5                               |
| 3           | 53 mm to 22.4 mm | 63 mm                | 100                                 |
|             |                  | 53 mm                | 95 – 100                            |
|             |                  | 45 mm                | 65 – 90                             |
|             |                  | 22.4 mm              | 0 – 10                              |
|             |                  | 11.2 mm              | 0 - 5                               |

**Note:** The compact thickness for a layer with Grading 1 shall be 100 mm while for layer with other Gradings i.e. 2 & 3, it shall be 75 mm.

**16.1.1.1 Overburnt (Jhama) Brick Aggregates:** Brick aggregate shall be made from over-burnt bricks and dense brick bats. It shall be homogeneous in texture, roughly cubical in shape, clean and free from dust, dirt and other objectionable and deleterious materials.

**16.1.1.2 Crushed or Broken Stone :** When crushed or broken stone is specified as the coarse aggregate, it shall be hard, durable and free from excess of flat, elongated, soft, disintegrated particles, dirt and other objectionable matter. The total quantity of such deleterious material including clay lumps, soft fragment, foreign material etc. shall not exceed 5% of the weight of the aggregate.

**16.1.1.3 Crushed Slag :** Crushed slag shall be made from air-cooled blast furnace slag. It shall be of angular shape, reasonably uniform in quality and density and generally free from thin, elongated and soft pieces, dirt or other deleterious materials. The weight of the crushed slag shall not be less than 11.2 kN per cubic metre (1120 kg per cubic metre) and the percentage of glossy material shall not be more than 20. Water absorption of slag shall not exceed 10% (IS 2386 Pt.III).

**16.1.1.4 Kankar :** Kankar shall be tough, having a blue almost opalescent fracture. It shall not contain any clay in the cavities between nodules.

**16.1.1.5 Laterite :** Laterite shall be hard, compact, heavy and of dark colour. The light coloured sandy laterite as well as those containing much ochreous clay shall be rejected.

**16.1.2 Aggregate-Fine**

The fine aggregate shall be the fraction passing 2.8 mm sieve and retained on 90 micron sieve. It shall consist of crusher run screenings, natural sand or a mixture of both. These shall be clean, hard, durable, uncoated, dry and free from injurious, soft or flaky pieces and organic or deleterious substance.

The contents of organic and deleterious materials shall not exceed the limits specified in Table 16.3.

**TABLE 16.3**

|  | <i>Uncrushed</i> | <i>Crushed</i> |
|--|------------------|----------------|
| Coal and lignite                                   | 1%               | 1%             |
| Clay lumps   | 1%               | 1%             |
| Material passing through 75 microns (I.S.S.) Sieve | 3%               | 3%             |
| Shale  | 1%               | 1%             |

The sum of the percentages of all deleterious material shall not exceed 5%. Tests for estimation of deleterious materials and organic impurities shall be done as per IS 2386 (Pt. II).

**16.1.3 G.I. Barbed Wire**

The barbed wire shall be of galvanised steel as specified and it shall conform to IS 278. The sampling criteria is given in Table 16.4. The wire shall be manufactured from steel by any process and shall not contain sulphur and phosphorous exceeding 0.065 per cent. The galvanised steel barbed wires shall be of two types: Type A (Lowa Type) and Type B (Glidden Type).

**Type A (Lowa Type) :** The barbs shall have four points and shall be formed by twisting two point wires, each two turns, tightly around both line wires making altogether four complete turns.

**Type B (Glidden Type) :** The barbs shall have four points and shall be formed by twisting two point wires, each two turns, tightly around one line wire making altogether four complete turns.

*Details of G.I. Barbed wire*

The galvanised steel barbed wire shall be of the size designations given in Table 16.4.

**TABLE 16.4**

| Size Designation | Nominal dia. of wire |        |            |        | Mass of completed Barbed Wire |       | Distance between two barbs | No. of lays between the two consecutive barbs |
|------------------|----------------------|--------|------------|--------|-------------------------------|-------|----------------------------|---|
|                  | Line Wire            |        | Point Wire |        | Max                           | Min   |                            |   |
|                  | Nom                  | Tol    | Nom        | Tol    |                               |       |                            |   |
|                  | (mm)                 | (mm)   | (mm)       | (mm)   | (g/m)                         | (g/m) |                            |   |
| 1.               | 2.50                 | ± 0.08 | 2.50       | ± 0.08 | 155                           | 136   | 75 ± 12                    | 2 to 7  |
| 2.               | 2.50                 | ± 0.08 | 2.50       | ± 0.08 | 120                           | 108   | 150 ± 12                   | 2 to 7  |
| 3.               | 2.50                 | ± 0.08 | 2.00       | ± 0.08 | 125                           | 108   | 75 ± 12                    | 2 to 7  |
| 4.               | 2.50                 | ± 0.08 | 2.00       | ± 0.08 | 103                           | 89    | 150 ± 12                   | 2 to 7  |
| 5.               | 2.24                 | ± 0.08 | 2.00       | ± 0.08 | 106                           | 97    | 75 ± 12                    | 2 to 7  |
| 6.               | 2.24                 | ± 0.08 | 2.00       | ± 0.08 | 85                            | 78    | 150 ± 12                   | 2 to 7  |

**Note :** The mass in g/m shall be obtained by dividing the total mass of the reel by the linear length in metres.

The number of lays between the two consecutive barbs shall vary between 2 to 7.

The barbed wire shall be formed by twisting together two line wires, one or both containing the barbs. The size of the line and point wires and barb spacings shall be as specified. The permissible deviation from the nominal diameter of the line wire and the point wire shall not exceed ± 0.08 mm. The line and point wires shall be circular in section, free from scales and other defects and shall be uniformly galvanised. The line wire, shall be in continuous lengths, and shall not contain any welds other than those in the rod before it is drawn. The distance between two successive splices shall not be less than 15 metres. It shall have the tensile properties as specified in Table 16.5.

**TABLE 16.5  
Tensile Properties**

| Size of Line Wire | Tensile Strength of line wire | Minimum Breaking Load of Completed Barbed Wire |
|-------------------|-------------------------------|--|
| mm                | kgf/sq. mm                    | kgf  |
| 2.50              | 40 to 60                      | 375  |
| 2.24              | 40 to 60                      | 300  |

The number of reels to be selected at random for this purpose shall be in accordance with Table 16.6.

**TABLE 16.6  
Sampling Criteria**

| No. of Reels in the Lot | No. of Reels to be selected |
|-------------------------|-----------------------------|
| Up to 25                | 3                           |
| 26 to 50                | 4                           |
| 51 to 150               | 5                           |
| 151 to 300              | 7                           |
| 301 and above           | 10                          |

#### 16.1.4 Binding Material

Binding materials to prevent ravelling of water bound macadam construction shall consist of a fine grained material possessing plasticity index value of 4 to 9 when the water bound macadam is to be used as a wearing course, and 4 to 6 when W.B.M. is being adopted as a sub-base/base course with bituminous surfacing on top of it. The plasticity index shall be determined in accordance with IS 2720 (Pt. V). The quantity of binding material used in each layer shall be as per direction of Engineer-in-Charge. Application of binding material may be dispensed with the approval of Engineer-in-Charge, where screenings consisting of crushable type material like moorum or gravel are used. Where earth cut for sub-grade formation is used as binder with the approval of Engineer-in-Charge, no separate payment shall be made for collection of this binder material.

#### 16.1.5 Bitumen Straight Run

A range of grades, from a very soft to a very hard consistency, can be produced by varying the temperature and the rate of flow during distilling process. It shall conform to IS 73. Grades of bitumen for different uses is given in Table 16.7.

**TABLE 16.7**  
**Bitumen Grades**

| <i>Grade</i> |  | <i>Temperature to which it shall be heated</i> |
|--------------|--|--|
| I.           | FOR PAINTING (Surface Dressing)  |  |
|              | 1. Paving bitumen of grade VG- 10  | 177 deg. C to 190 deg. C                       |
|              | 2. Paving bitumen of grade VG- 30  | 177 deg C to 190 deg. C                        |
|              | 3. Bitumen emulsion min. 50% bitumen content:- RS grade IS 8837              | (Cold application)                             |
|              | 4. Cut backs RC-3 (rapid curing) IS 217                                      | —do—   |
| II.          | FOR PREMIX CARPETING   |  |
|              | 1. Paving asphalt 30/40 S-35 or 80/100 S-90                                  | 149 deg. C to 177 deg. C                       |
|              | 2. Bitumen Emulsion min. 60% bitumen contents RS grade IS 8837               | (Cold application)                             |
|              | 3. Cut back MC (medium curing) IS 4545                                       | (Cold application)                             |
| III.         | FOR ASPHALTIC CONCRETE STRAIGHT RUN BITUMEN 60/70 (S-65) CONFORMING TO IS 73 | 150 deg. C to 177 deg. C                       |

**Note :** For premix carpeting with paving asphalt, extra shall be paid if solvent is used.

#### 16.1.6 Bricks

Bricks shall be of class designation 75 unless otherwise stated. The specifications of bricks shall be as sub head brick work as detailed in subhead 6.0 Vol – I, CPWD Specification – 2019.

#### 16.1.7 Filler

The filler, where specified, shall be an inert material, the whole of which passes through a 710 micron sieve, atleast 90 per cent passing through a 180 micron sieve and not less than 70 per cent passing through a 90 micron sieve. The filler shall be cement, stone dust, hydrated lime, lime stone dust, flyash or any other non-plastic mineral matter approved by the Engineer-in-Charge.

**TABLE 16.8**  
**Aggregate Gradation including Filler**

| <i>Sieve designation</i> | <i>Percent by weight passing the sieve</i> |                            |
|--------------------------|--|----------------------------|
|                          | <i>For 25 mm thickness</i>                 | <i>For 20 mm thickness</i> |
| 20.0 mm                  | 100  | -                          |
| 12.5 mm                  | 75-100                                     | 100                        |
| 10.0 mm                  | 60-85                                      | 75 – 100                   |
| 4.75 mm                  | 35-55                                      | 35 – 55                    |
| 2.36 mm                  | 20-35                                      | 20 – 35                    |
| 600 micron               | 10-22                                      | 10 – 22                    |
| 300 micron               | 6-16                                       | 6 – 16                     |
| 150 micron               | 4-12                                       | 4 – 12                     |
| 75 micron                | 2- 8                                       | 2 - 8                      |

**16.1.8 Flyash**

Flyash shall conform to IS 3812

**16.1.9 Lime**

Lime shall be of specifications as directed by Engineer-in-Charge.

**16.1.10 Moorum**

It shall be obtained from pits of weathered disintegrated rocks. It should preferably contain silicious material and natural mixture of clay of calcarious origin. The size of moorum shall not be more than 20 mm.

**16.1.11 Posts, Rails and Pales**

These shall be of standard size and length of posts being 1.8 m, rails 2.25 m and pales 1.25 m unless otherwise specified. A tolerance of 12 mm in length and 3 mm in other dimensions shall be permissible. These shall be cast in cement concrete 1:1 ½ 3 (1 cement : 1 ½ coarse sand : 3 graded stone aggregate 12.5 mm nominal size) with slots and reinforced with tor steel bars of diameters 10 mm in the case of posts and pales and 8 mm in the case of rails or as directed and finished with cement mortar 1:2 (1 cement :2 fine sand). The specifications for R. C. C. work shall apply.

For the whole of their length below the top of the rail the paling shall have a projecting dovetail shape at the back which shall fit into dovetail grooves in each of the rails. That part of the palings projecting above the top rail shall be left square to prevent the dropping right through the rails. The posts, rails and pales shall be free from cracks, twists and such other defects.

**16.1.12 Posts and Struts—R.C.C.**

All posts and struts shall be of standard size, the length of posts being 1.8 m or as specified and that of struts being minimum of 2.0 m. These shall be cast in cement concrete 1:1 ½ :3 (1 cement : 1 ½ coarse sand : 3 graded stone aggregate 12.5 mm nominal size) reinforced with 10 mm diameter tor steel bars as directed and finished smooth with cement mortar 1:2 (1 cement: 2 fine sand). The specifications for R.C.C. work shall apply. The posts and struts shall be free from cracks, twists and such other defects. G.I. staples on wooden plugs or 6 mm bar nibs will be provided as directed by Engineer-in-Charge while casting the posts. Quantity of RCC post, struts, Rails and Pales to be measured in cubic content.

**16.1.13 Premoulded Joint Filler**

It shall conform to IS 1838, the thickness shall be 20 mm or 25 mm as specified and shall be of the maximum available standard length. During the casting of the slab the premoulded joint filler shall be placed accurately in position against the finished end of concrete slab. The filler shall remain 20 mm below the top surface of the pavement and shall extend upto the subgrade.



#### 16.1.14 Red Bajri

This shall be disintegrated rock dark red in colour consisting of coarse grains, free from mica, dust and other foreign matter.

#### 16.1.15 Screenings

Screening to fill voids in the coarse aggregate shall generally consists of the same material as the coarse aggregate. However, where permitted, predominantly non-plastic material such as moorum or gravel (other than river borne rounded material) may be used for this purpose provided liquid limit and plasticity index of such material is below 20 and 6 respectively and fraction passing 75 micron sieve does not exceed 10 percent.

As far as possible screenings shall conform to the gradings set-forth in Table 16.9. Screenings of type A shall be used with coarse aggregate of grade I of Table 16.2. Screenings of type A or B as specified shall be used with coarse aggregates of grading 2. Type B screenings shall be used with coarse aggregates of grading 3. The use of screenings may be omitted in the case of soft aggregates such as brick metal, kankar and laterite. For screenings like moorum or gravel the gradings given in Table 16.9 shall not be binding.

**TABLE 16.9**  
**Grading for Screenings**

| <i>Grading Classification</i> | <i>Size of Screenings</i> | <i>IS Sieve Designation</i> | <i>Percent by Weight Passing Sieve</i> |
|-------------------------------|---------------------------|-----------------------------|--|
| A                             | 13.2 mm                   | 13.2 mm                     | 100                                    |
|                               |                           | 11.2 mm                     | 95 -100                                |
|                               |                           | 5.6 mm                      | 15 - 35                                |
|                               |                           | 180 micron                  | 0 – 10                                 |
| B                             | 11.2 mm                   | 11.2 mm                     | 100                                    |
|                               |                           | 9.5 mm                      | 80-100                                 |
|                               |                           | 5.6 mm                      | 50 - 70                                |
|                               |                           | 180 micron                  | 05 - 25                                |

#### 16.1.16 Sealing Compound

After the curing period is over the joint portion above the filler board shall be cleaned thoroughly as directed by the Engineer-in-Charge. The joints shall be filled with hot applied sealing compound. Grade A (Normal) for concrete constructions other than those which are subjected to spillage of kerosene or other heavy petroleum oils and Grade B (Jet fuel resistant) for concrete constructions of runways for jet air crafts, conforming to IS 1834.

#### 16.1.17 Soil

Soil having a plasticity index (PI) between 5 and 20 shall be suitable. Atleast one test for 200 cubic metre of soil for determining P.I. shall be conducted.

#### 16.1.18 Stones

These shall be clean, hard, sound and durable stones, free from decay and weathering. They shall be in blocks and hammer dressed on all sides. The size of pitching stones shall be approximately 22.5 cm in depth and not less than 15 cm in any other direction.

#### 16.1.19 Stone Chippings For Surface Dressing/Painting

The stone chipping shall consist of fairly cubical fragment of clean, hard, tough and durable rock of uniform quality throughout. These shall be obtained by crushing stone river gravel (shingle) or other approved materials. Rounded gravel shall be used only if specifically permitted by the Engineer-in-Charge. The chipping shall be free of elongated or falky pieces, soft or disintegrated stone, salt, alkali, vegetable matter, dust and adherant coatings. They shall conform to the quality requirements of Table 16.10.

However, the total quantity of such deleterious material including clay lumps, soft fragments, foreign material shall not exceed 5% of the weight of the aggregate.

The aggregate shall be got tested to ensure the requirements specified in Table 16.10.

**TABLE 16.10**  
**Physical Requirements of Aggregates for Surface Dressing**

| <i>Sl. No.</i> | <i>Test</i>               | <i>Test method</i> | <i>Requirements</i> |
|----------------|---------------------------|--------------------|---------------------|
| 1.             | Los Angles Abrasion Value | IS 2386 (Part-4)   | 40% (Max.)          |
| 2.             | Aggregate Impact Value*   | IS 2386 (Part-4)   | 30% (Max.)          |
| 3.             | Flakiness Index           | IS 2386 (Part-1)   | 25% (Max.)          |
| 4.             | Stripping Value           | IS 6241            | 25% (Max.)          |
| 5.             | Water Absorption          | IS 2386 (Part-3)   | 1% (Max.)           |

\* Aggregates may satisfy requirements of either of the two tests.

#### **16.1.20 Stones for Kerb and Channels (Fig. 16.12)**

Kerb and channel stones are provided on roads having raised berms for foot path etc. These shall be of selected hard stone, sound, durable free from laminations and other structural defects. The length of each kerb and channel stone shall be not less than 49.5 cm except that 29.5 cm long stones shall be permitted for closures and for curves. The other dimensions shall be 30 x 20 cm for kerb stones and 30 x 10 cm for channel stones, unless specified otherwise. Kerb and channel stones shall be chisel dressed on exposed surface and edges. The dimensions of the exposed faces of kerb and channel stones shall be of sizes as specified with a tolerance of 10 mm in width and depth. In the case of kerb stones a tolerance of 5 cm shall be allowed in the dimensions of unexposed back and bottom faces and in the case of channel stones a tolerance of 10 mm shall be allowed in thickness.

#### **16.1.21 Boundary Stone (Fig. 16.4)**

The boundary stones shall be of either hard stone or sound and durable quality or precast R.C.C. These shall be in blocks of size 15 x 15 x 90 cm unless directed otherwise by the Engineer-in-Charge. A tolerance of 12.5 mm shall be permitted in the specified size. In the case of boundary stones of hard stone, the upper 30 cm shall be chisel dressed on all the four sides and on the top.

The R.C.C. boundary stones shall be cast in cement concrete 1 : 1 ½ : 3 (1 cement : 1 ½ coarse sand : 3 graded stone aggregate 20 mm nominal size), reinforced with 10 mm diameter tor steel bars or as directed and finished smooth with cement mortar 1 : 3 (1 cement : 3 fine sand ). The specifications for R.C.C. work shall apply.

#### **16.1.22 Kilometer stone (Fig.16.7)**

Standard design of kilometer stones are given in Fig. 16.7. Ordinary kilometer stone for National Highways, State highways and Major District shall be of the size 35 x 111 x 25 cm. One cm offset shall be provided around the stone slab in 10 cm height above the formation level to serve as the pedestal. The kilometer stones shall be fixed at right angle to the centre line of the carriage way. The kilometre stone shall indicate the name and distance of the next (intermediate) important town only. On the side of the kilometre stone facing the carriage way, the number of the kilometre stone shall be inscribed (without the name of any place) which shall be painted later on.

Kilometre stones for every fifth kilometre on National Highways, State highways and major district roads shall be of the size 50 x 152.5 x 25 cm. One cm offset shall be provided around the stone slab in 13 cm height above the formation level to serve as the pedestal. This kilometre stone shall be fixed at right angles to the centre line of carriage way. It shall show the name and distance of the terminal or the starting station also above those of intermediate towns. On the side facing the carriage way, the number of the kilometre stone in continuity of ordinary kilometre stone shall be inscribed (without the name of any place) which shall be painted later on.

Kilometre stone for other district roads and village roads shall be of the size 35 x 93.5 x 18 cm. One cm offset shall be provided around the stone slab in 10 cm. height above the formation level to serve as the pedestal. It shall be fixed at right angles to the centre line of carriage way and shall indicate the name and the distance of the next important station. On the side facing the carriage way, the number of the kilometre stone shall be inscribed (without the name of any place).

The kilometre stones shall be fixed at the edge of the road way outside the shoulder on especially erected platforms, if necessary. In cutting these shall be fixed clear of the shoulder and the side drain as per Fig. 16.7(A). On existing roads the stones shall be fixed on the side of the road other than that on which miles stones exist. On new roads, these shall be located on left hand side of the road as one proceeds from the station from which kilometre count starts.

Kilometre stones shall be of approved design of R.C.C. or stone slabs.

(a) *Kilometre Stones in R.C.C.* : It shall be cast in cement concrete 1:2:4 (1 cement : 2 coarse sand : 4 graded stone aggregate 20 mm nominal size) with reinforcement as directed and finished smooth with cement mortar 1 : 3 (1 cement : 3 fine sand) on exposed surfaces above the ground. The specifications for R.C.C. work shall apply.

(b) *Kilometre Stone Slabs* : The stone slabs shall be of red or white sand stone unless otherwise specified. The slab shall be hard, even, sound and durable. The stone slabs shall have been sawn or chiseled in a plane parallel to the natural bed of the stone. The slabs shall be chisel dressed on the exposed surfaces above ground facing road side, so that the dressed face shall not be more than 3 mm from a straight edge placed on it. The thickness of the slab shall be uniform and as specified in the item with a permissible tolerance of 1.5 mm. The thickness shall be measured correct to 3 mm.

## **16.2 SUB-GRADE : PREPARATION AND CONSOLIDATION**

**16.2.0** In sub-grade composed of clay, fine sand or other soils that may be forced up into the coarse aggregate during rolling operation, an insulation layer of suitable thickness of granular materials or over size brick aggregate not less than 10 cm thick shall be provided for blanketing the sub-grade, which shall be paid for separately, unless otherwise specified in the agreement.

In slushy soils or in areas that are water logged, special arrangements shall be made to improve the sub-grade and the total pavement thickness shall be designed after testing the properties of the sub-grade soil. Necessary provision for the special treatment required shall be made in the project and paid for separately.

### **16.2.1 Preparation of Sub-Grade**

The surface of the formation for a width of sub-base, which shall be 15 cm more on either side of base course, shall first be cut to a depth equal to the combined depth of sub-base and surface courses below the proposed finished level (due allowance being made for consolidation). It shall then be cleaned of all foreign substances. Any ruts or soft yielding patches that appear due to improper drainage conditions, traffic hauling or from any other cause, shall be corrected and the sub-grade dressed off parallel to the finished profile.

### **16.2.2 Consolidation**

The sub- grade shall be consolidated with a power road roller of 8 to 12 tonnes. The roller shall run over the sub grade till the soil is evenly and densely consolidated and behaves as an elastic mass (the roller shall pass a minimum of 5 runs on the sub grade). All undulations in the surface that develop due to rolling shall be made good with material or quarry spoils as the cases may be and the sub-grade is rerolled.

### **16.2.3 Surface Regularity**

The finished surface shall be uniform and conform to the lines, grades and typical cross section shown in the drawings, when tested with the template and straight edge, the variation shall be within the tolerances specified in Table 16.11.

**TABLE 16.11**  
**Permissible Tolerances of Surface Evenness of Sub Grade**

|   |  |
|---|--|
| <i>Longitudinal profile maximum permissible undulation when measured with a 3 metre straight edge</i> | <i>Cross profile maximum permissible variation from specified profile when measured with a camber template</i> |
| 24 mm   | 15 mm  |

Where the surface irregularity of the sub grade falls outside the specified tolerances, the contractor shall be liable to rectify these with fresh material or quarry spoils as the case may be, and the sub-grade rerolled to the satisfaction of Engineer-in-Charge.

#### **16.2.4 Measurements**

The length and width shall be measured correct to a cm. The area shall be worked out in square metre, correct to two places of decimal.

#### **16.2.5 Rate**

The rate for preparation and consolidation of sub grade shall include the cost of materials and labour involved for all the operations mentioned in above unless otherwise specified.

### **16.3 EMBANKMENT CONSTRUCTION (UNDER OPTIMUM MOISTURE CONDITIONS)**

**16.3.1** In the case of earth work consolidated under optimum moisture conditions each layer of earth shall be carefully moistened to give field moisture content of about +1% to -2% of the optimum moisture content (OMC). The OMC shall be determined according to IS 2720 (Pt.VIII) Methods of Tests for Soils. Each layer shall then be compacted by rolling with 8 to 10 tonnes power road roller and a sheep foot roller if required. The required amount of water shall be added during consolidation to keep the moisture content of the soil at the optimum as per test. The density to be achieved for each layer of the material shall not be less than 95% of the density obtained in the laboratory (Proctor Method).

**16.3.2** Each compacted layer shall be tested in the field for density and accepted before the operations for next layer are begun.

**16.3.3** Control on compaction in the field shall be exercised through frequent moisture content and density determinations. A systematic record of these shall be maintained. At all times during construction the top of the embankment shall be maintained at such cross fall as will shed water and prevent ponding.

#### **16.3.4 Density Measurement and Acceptance Criteria**

**16.3.4.1** One measurement of density shall be made for each 500 sqm of compacted area or for a smaller area as decided by the Engineer-in-Charge. Each measurement shall consist of atleast 5 density determinations tests and the average of these 5 determinations shall be treated as the field density achieved. The determination of density shall be as per IS 2720 (Pt. XXVIII).

**16.3.4.2** In general the control at the top 40 cm thickness of the formation shall be more strict with density measurements being done at the rate of one measurement for 250 sqm of compacted area. Further for the determination of the mean density the number of tests in one measurement shall not be less than 10 and the work will be accepted if the mean dry density equals or exceeds the specified density.

**16.3.4.3** When density measurements reveal any soft areas in the embankment, the Engineer-in-Charge shall direct that these be compacted further. If in spite of that the specified compaction is not achieved the material in the soft areas shall be removed and replaced by approved materials and compacted to the satisfaction of the Engineer-in-Charge.

#### **16.3.4.4 Control Tests on Borrow Material**

**16.3.4.5** Soil suitable for consolidation under O.M.C. conditions should preferably have the following characteristics :

- |  |     |
|--|-----|
| (a) Minimum percentage of clay                   | 10% |
| (b) Liquid limit                                 | 14  |
| (c) Plasticity index                             | 4   |
| (d) Percentage of silt should not exceed         | 50% |
| (e) Peat, muck and organic soils are unsuitable. |     |

**16.3.4.6** The Engineer-in-Charge may, however, relax these requirements taking into account availability of materials, cost of transportation and other relevant factors.

**16.3.4.7** Various test required to be conducted on the borrow material with their recommended frequency are indicated below. All the test need not be stipulated on every project. Depending upon site condition etc. only some may be found necessary at a particular project. The frequency of testing indicated refers generally to the minimum number of tests to be conducted. The rate of testing must be stepped up as found necessary depending upon the variability of the materials and compaction methods employed at a project.

- (a) *Gradation* : At least one test for each kind of soil. Usual rate of testing 1 to 2 tests per 8000 cum of soil.
- (b) *Plasticity* : At least one test for each kind of soil. Usual rate of testing 1 to 2 tests per 8000 cum of soil.
- (c) *Proctor Tests* : At the rate of 1 to 2 tests per 8000 cum of soil.
- (d) *Deleterious Contents* : As required.
- (e) *Moisture contents* : One test for every 250 cum of soil.

**16.3.4.8 Measurements** : The filling shall be measured and quantity of earth work computed from cross sections of filling or the embankment. No deduction shall be made for voids.

**16.3.4.9** Rate shall include the cost of all operations described above including operation mentioned in 16.3 to the extent applicable.

### **16.4 SUPPLYING AND STACKING OF MATERIALS**

#### **16.4.1 Aggregates/Red Bajri**

**16.4.1.0** The item of work shall specify stone aggregate/brick aggregate/red bajri etc., as the case may be.

**16.4.1.1 Stacking** : Ground where stacks are proposed to be made shall be cleared, levelled or dressed to a uniform slope and all lumps, depressions etc. shall be removed. The stacked metal shall be free from vegetation and other foreign matter. Coarse aggregates stack shall be made at places as directed by the Engineer-in-Charge. All rejected stone metal shall be removed from the site.

The aggregate shall be stacked in convenient units of one metre top width, 2.2 m bottom width, 60 cm height and of length in multiples of 3 m for new roads. Where berm width is limited or for repair works it shall be stacked in units of 40 cm top width 1.4 m bottom width, 50 cm height and length in multiples of 3 m. Template of steel shall be used for making the stacks and shall always be kept at site for check measurements. The Engineer-in-Charge may permit stacking in different sizes and height ranging between 45 to 75 cm for new roads and 40 to 60 cm for repair work, in case the site conditions so demand. In a particular reach of road as decided by the Engineer-in-Charge, the quantity of stacked material shall be comparable to the theoretical quantity required for W.B.M. to be laid in that reach.

The stacks shall be uniformly distributed along the road and shall be numbered serially. The number plate shall be planted on each stack, which shall remain in position until the stack is used in the work. A register showing daily consumption of stacks shall be maintained at site of work. The collection of stone metal shall be for completed length of one km (for each layer of W.B. macadam) or as directed by the Engineer-in-Charge in writing.

**16.4.1.2 Measurements :** Length, breadth and height shall be measured correct to a cm. The total quantity so arrived shall be reduced by 7.5% to arrive at the net quantity for payment, in cases of aggregates. No such reduction shall be made in case of fine aggregate i.e. Red Bajri & screening etc. as defined under clause 16.1.1 to 16.1.2.

#### **16.4.2 Binder**

**16.4.2.1 Stacking :** Specified binder shall be brought to the site of work in the sealed original containers. Binder brought in damaged containers shall not be allowed. The material shall be stacked in fenced enclosures, as directed by the Engineer-in-Charge, on one side of the roadway. The material shall be purchased from reputed firms or their authorised dealer. All the drums brought to site shall be serially numbered and used in the same order. The materials shall be brought in at a time in adequate quantities to suffice for the whole work or for atleast a fortnight's work.

For major bituminous road works, supply of bitumen in bulk may be taken for economical reasons, or if the contingencies of the work so require. Sufficient storage arrangement shall be made at site for atleast ten days requirement.

Materials shall be kept in the joint custody of the contractor and the representative of the Engineer-in-Charge. The empty containers shall not be removed from the site of work, till the relevant item of work has been completed and permission obtained from the Engineer-in-Charge. A few drums may be removed before completion of work for heating bitumen and mixing aggregates etc. with the permission to the Engineer-in-Charge.

Empty drums required to be returned to stores shall be in good condition. Recovery rate for non-return of the empty drums or for the damaged drums shall be as decided by the Engineer-in-Charge.

**16.4.2.2 Measurements :** The materials shall be recorded as per standard weights of different type of container as intimated by manufacturers. The material shall be weighed where containers are found leaking.

**16.4.2.3 Rate :** The rate shall include the cost of all labour and materials involved in all the operations described above.

#### **16.4.3 Moorum/Stone Chippings/Good Earth**

**16.4.3.0** The item of work shall specify moorum/stone chippings/Good Earth as the cases may be.

**16.4.3.1 Stacking :** Ground where stacks are proposed to be made, shall be dressed to a uniform slope and all lumps, depressions etc. shall be removed. Sample of moorum shall be got approved from the Engineer-in-Charge, before the material in bulk is brought to site.

Moorum/Good Earth shall be stacked in convenient units of one cubic metre in between aggregate stacks in each length of 100 m as per requirement. The stacks shall be made with wooden boxes open at both ends and of 2 × 2 × 0.25 m dimensions. These shall always be kept at site for stacking and check measurement.

The stacks shall be uniformly distributed along the road. The supply of moorum shall be completed for the entire work or for a complete length of one km or as directed by the Engineer-in-Charge in writing.

**16.4.3.2 Measurements :** Length and breadth of boxes shall be measured correct to a cm. Volume shall be calculated in cubic metres, correct to two places of decimal.

**16.4.3.3 Rate :** The rate shall include the cost of all materials and labour involved in all the operations described above.



## **16.5 EARTHWORK IN ROAD CONSTRUCTION**

**16.5.1** Earthwork connected with road construction fall broadly into three categories.

- (a) Earthwork in cutting including borrow pits.
- (b) Earthwork in fillings in embankments (without optimum moisture conditions).
- (c) Earthwork in fillings in embankments (under optimum moisture conditions).

**16.5.2** Detailed specifications relating to Earthwork already described in subhead Earth Work, CPWD Specification Vol- I, 2019 so far as the various options in the earthwork for road construction as indicated below shall be applicable.

- Site clearance
- Setting out and making profile
- Blasting operations
- Excavation in all kinds of soils
- Excavation in ordinary/hard rock
- Earthwork in filling
- Measurements
- Rates
- Surface excavation
- Rough excavation and filling

**16.5.3** In addition to the above, there are certain special requirements of earthwork for road constructions, especially in embankments and excavations from borrow pits. These shall broadly conform to.

- (a) IRC : 36 Recommended practice for construction of earth embankments for road works.
- (b) IRC : 10 Recommended practice for borrow pits for road embankments by manual operations.

Excavation from borrow pits shall conform to provisions in para 3 of IRC: 10 and the road embankment shall generally conform to section, slopes and location of borrow pits as per Fig. given in CPWD Specifications Vol. I, 2019.

## **16.6 EMBANKMENT CONSTRUCTION (WITHOUT OPTIMUM MOISTURE CONDITIONS)**

**16.6.0** In addition to what is described in 16.5 above, the following shall apply : materials used in embankments shall be earth moorum, gravel, a mixture of these or any other material approved by the Engineer-in-Charge. Such materials shall be free of logs, stumps, roots, rubbish or any other ingredient likely to deteriorate or affect the stability of the embankment. The work shall be so planned and executed that the best available materials are saved for the top portion of the embankment.

Highly expansive clays exhibiting marked swell and shrinkage properties may be deposited only at the bottom of the embankment and no such material shall be placed nor permitted to remain in the top 500 mm portion of the embankment below the sub-grade.

### **16.6.1 Preparation of Foundations**

The foundations of the embankment shall be ploughed to a depth of 15 to 25 cm. All clods shall be broken into fine earth and the area roughly levelled. The surface shall then be well watered before the earth work is started.

### **16.6.2 Source of Supply**

**16.6.2.1** The material used in embankment shall be obtained either from cutting high ground or from borrow pits as directed by the Engineer- in-Charge. In case of road embankments, the borrow pits may be excavated

along the sides of the road so as to form road side drains with proper slopes and sections. The clear berm width between the toe of the bank and the inner edge of the borrow pits shall be specified by the Engineer-in-Charge but it shall not be less than 5 metres after making due allowance for future development.

**16.6.2.2** Borrow pits shall be rectangular in shape with one side parallel to the centre line of the road. If on road land, these shall be dug as near the boundary as possible. Borrow pits shall not be dug continuously. Ridges of not less than 8 metres width should be left at intervals not exceeding 300 metres. Small drains should be cut through the ridges to facilitate drainage. Borrow pits shall be well drained. The bed level of the borrow pits, shall, as far as possible, slope down progressively towards the nearest cross drain, if any and shall not be lower than the bed of the cross drain. Borrow pits shall not be dug within 0.8 km of towns or villages. If unavoidable these shall not exceed 30 cm in depth and shall be drained.

**16.6.2.3** Where it becomes necessary to borrow filling materials from temporarily acquired cultivable lands the depth of borrow pits shall not exceed 45 cm. The top soil to a depth of 15 cm shall be stripped and stacked aside. Thereafter soil shall be dug out to a further depth not exceeding 30 cm and used in forming the embankment. The top soil shall then be spread back on the land.

**16.6.2.4** In case of flood and marginal banks, earth shall be obtained from borrow pits on the river side of the banks. No borrow pit shall be excavated on the land side of the bank, unless permitted by the Engineer -in-Charge in writing depending upon the depth of borrow pits and height of embankment. However the minimum berm width between the toe of the bank and the edge of the borrow pits on the river side shall be 15 metres and that between the toe of the bank and the edge of the borrow pits on the land side 25 metres.

**16.6.2.5** Guide-banks shall be constructed from material obtained from excavation for laying stone aprons and further borrow pits excavated if necessary, according to the directions of the Engineer-in-Charge.

### **16.6.3 Earth Filling and Compactions**

**16.6.3.1** Before commencement of filling the toe lines of the embankment shall be marked by pegs driven into the ground at 15 metres intervals and by continuous nicking (daf balings) to indicate the limits of the side slopes. Bamboo and string profiles shall be erected at every 60 metres interval in straight reaches and 15 metres apart in curved portions.

**16.6.3.2** Embankment material shall be laid in 20 cm layers which shall be continuous and parallel to the finished grade. The placing of earth fill shall be done in the full width of embankment including slopes, and the section of formation shall be kept slightly sloping away from the centre to avoid pools of water forming due to rain. The height of filling in different sections shall be uniform as far as possible. All clods shall be broken while the earth is being placed. Organic matter of any kind shall be removed and disposed off as directed by the Engineer-in-Charge.

**16.6.3.3** Joining of old and new embankments shall be done by stepping in an overall slope of about 1 to 5.

**16.6.3.4** Each layer of earth shall be adequately watered to aid compaction.

**16.6.3.5** If the material delivered to the road bed is too wet it shall be dried by aeration and exposure to the sun, till the moisture content is acceptable for compaction. It shall then be rolled with roller of minimum 1/2 tonne weight, not less than 5 times, till it gets evenly and densely consolidated with wooden or steel rammers of 7 to 10 kg weight having a base of 20 cm square or 20 cm diameter. The labour for ramming shall be atleast one rammer to six diggers. Every third layer of earth and the top most layer shall be well consolidated with a power roller of minimum 8 tonnes weight, rolled not less than 5 times, till the soil behaves as an elastic material and gets compressed only elastically under the load of roller.

**16.6.3.6 Dressing :** The embankment shall be dressed neatly to the required level as per designed section and grade, after it has been completed and thoroughly consolidated. The top and slopes shall be protected from any damage and maintained, till the work is completed and handed over to the Engineer-in-Charge.



#### **16.6.4 Embankment Around Structures**

**16.6.4.1** To avoid interference with the construction of abutments, wing walls or return walls of culvert/bridge structure, the contractor shall at points to be determined by the Engineer-in-Charge suspend work on embankments forming approaches to such structures, until such time as the construction of the latter of sufficiently advanced to permit the completion of approaches without the risk of interference of damage to the bridge works.

**16.6.4.2** Unless directed otherwise, the filling around culverts, bridges and other structures upto a distance of twice the height of the embankment shall not be done. The fill material shall not be placed against any abutment or wing wall unless permission has been given by the Engineer-in-Charge but in any case not until the concrete or masonry has been in position for 14 days. The embankment shall be brought up simultaneously in equal layers on each side of the structure to avoid displacement and unequal pressure. The sequence of work in this regard shall be got approved from the Engineer-in-Charge.

**16.6.4.3.** Where the provision of any filter medium is specified behind the abutment, the same shall be laid in layers simultaneously with the laying of fill material. The material used for filter material shall conform to the requirements for filter medium as specified. Payment for providing filter material shall be made separately under relevant items.

**16. 6.4.4.** Where it may be impracticable to use power roller or other heavy equipment, compaction shall be carried out by mechanical tampers or other methods approved by the Engineer-in-Charge. Care shall be taken to see that the compaction equipments does not hit or come too close to any structural member so as to cause any damage to it.

#### **16.6.5 Earth Work for Widening Existing Road Embankment**

**16.6.5.1** When an existing embankment is to be widened and its slope is steeper than 4:1 continuous horizontal benches each at least 0.3 metre wide, shall be cut into the old slope for ensuring adequate bond with the fresh embankment material to be added. The material obtained from cutting of benches could be utilised in the widening of the embankment. However, when the existing slope against which the fresh material is to be placed is flatter than 4:1 the slope surface may only be ploughed or scarified instead of resorting to benching.

**16.6.5.2** Where the width of the widened portion is insufficient to permit the use of standard rollers compaction shall be carried out with the help of sheep's foot roller mechanical tampers or other approved equipment. End dumping of material from trucks for widening operations shall be avoided except in difficult circumstances when the extra width is too narrow to permit the movement of any other type of hauling equipment.

#### **16.6.6 Cutting**

Where the formation level of the road is lower than the ground level, cutting shall be done up to formation level. Side slopes except in rock cutting shall be evenly and truly dressed.

**16.6.6.1 Disposal of Surplus Earth :** Earth from cutting shall be utilized for filling in embankment as directed by the Engineer-in-Charge. Earth not required for embankment shall be disposed off as directed by the Engineer-in-Charge. The area where the surplus earth is disposed off shall be levelled and neatly dressed. When the surplus earth is disposed off at a distance of more than 50 metres the extra lead shall be paid for.

**16.6.6.2 Measurements :** The quantity of earth work shall be calculated by measuring the volume of earth excavated from the borrow pits and shall be done as specified where it is not possible or convenient to take measurements from cutting the filling shall be measured and the quantity of earth work computed from cross sections of the filling. The quantity of earth work so computed shall be reduced by 5% to arrive at the quantity for payment.

For the purpose of taking measurements of earth work in cutting or embankment, ground levels of the area shall be recorded as specified in 16.5.

**16. 6.6.3 Rate :** It includes the cost of all the operations described above. The lead and lift for depositing the earth or disposal of unsuitable material shall be as described in the description of item. It also includes the Sub Head 2.0 Earth Work.

## 16.7 WATER BOUND MACADAM WITH STONE AGGREGATE

### 16.7.1 Water Bound Macadam with Stone Aggregate

Stone aggregate of specified size is used. This is a standard sub base/base and is used where stone aggregate is available at reasonable rates. This consists of clean crushed coarse aggregate mechanically interlocked by rolling and voids thereof filled with screening and binding material with the assistance of water, laid on a prepared sub grade, sub-base, base or existing pavement as the case may be. Water bound macadam may be used as a sub base, base course or surfacing course.

### 16.7.2 Approximate Quantities of Materials

Quantities of coarse aggregate, screening and binding material required to be stacked for 100 mm approximate compacted thickness of W.B.M. for 10 sqm shall be as per table 16.12 for stone aggregate of the size 90 mm to 45 mm. For stone aggregate of other size, 63 mm to 45 mm and 53 mm to 22.4 mm quantity of coarse aggregate and stone screening for 75 mm approximate compacted thickness of WBM base for 10 sqm. shall be as per Table 16.13.

**TABLE 16.12**

| Coarse Aggregate |                |                      | Stone Screenings                |                      | Binding Material     |
|------------------|----------------|----------------------|---------------------------------|----------------------|----------------------|
| Classification   | Size Range     | Loose Quantities     | Grading/classification and size | Loose Quantity       | Quantity             |
| Grading 1        | 90 mm to 45 mm | 1.21 cum to 1.28 cum | Type A<br>13.2 mm               | 0.27 cum to 0.30 cum | 0.08 cum to 0.10 cum |

**Note :** Net quantity = Loose quantity measured in stacks minus 7.5%.

**TABLE 16.13**

| Coarse Aggregate |            |                     |                             | Stone Screenings              |   |   |
|------------------|------------|---------------------|-----------------------------|-------------------------------|---|---|
| Classification   | Size Range | Compacted Thickness | Loose Quantity              | Grading Classification & Size | For WBM Sub-base/Base Course (Loose Quantity) | For WBM surface course (Loose Quantity) |
| Grading 2        | 63-45 mm   | 75 mm               | 0.91 to 0.96 m <sup>3</sup> | Type A<br>13.2 mm             | 0.12 cum to 0.15 cum                          | 0.10 cum to 0.12 cum                    |
| -Do-             | -do-       | -do-                | -do-                        | Type B<br>11.2 mm             | 0.20 cum to 0.22 cum                          | 0.16 cum to 0.18 cum                    |
| Grading 3        | 53-22.4 mm | 75 mm               | -do-                        | Type B<br>11.2 mm             | 0.18 cum to 0.21 cum                          | 0.14 cum to 0.17 cum                    |

- \* **Note :**
1. The quantity of metal measured in stacks and reduced by 7.5% to calculate net quantity.
  2. The above mentioned quantities should be taken as a guide only for estimation of quantities for construction etc.

**16.7.3** The quantity of binding material required for 75 mm (approximate) compacted thickness will be 0.09 cum/10 sqm in the case of W.B.M. base course and 0.13 cum/10 sqm when the W.B.M. is to function as a surface course.

### 16.7.4 Preparation of Foundation

In the case of an existing unsurfaced road, where new materials is to be laid, the surface shall be scarified and reshaped to the required grade, camber and shape as necessary. Weak places shall be strengthened, corrugations removed and depressions and pot holes made good with suitable materials, before spreading the aggregate for W.B.M.

Where the existing surface over which the sub base of W.B.M. is to be laid is black topped, to ensure effective internal drainage, furrows 50 mm x 50 mm (depth of furrows increased to reach bottom of bituminous layer where necessary) at one metre intervals shall be cut in the existing bituminous surface at 45 degree C to the central line of the carriageway before the W.B.M. is laid.

#### **16.7.5 Provision of Lateral Confinement of Aggregates**

Before starting with W.B.M. construction, necessary arrangements shall be made for lateral confinement of aggregates. One method is to construct side shoulders in advance to a compacted layer of the W.B.M. coarse (Fig. 16.1). Inside edges may be trimmed vertical and the included area cleaned off all spilled materials thereby setting the stage for spreading the coarse aggregate.

The practice of laying W.B.M. after excavating a trench section in the finished formation must be completely avoided.

#### **16.7.6 Spreading Aggregate**

The coarse aggregate shall be spread uniformly and evenly upon the prepared base in required quantities with a twisting motion to avoid segregation. In no case shall these be dumped in heaps directly on the area where these are to be laid nor shall their hauling over a partly completed base be permitted. The aggregates shall be spread uniformly to proper profile by using templates placed across the road six metres apart. Where specified, approved mechanical devices may be used to spread the aggregates uniformly. The levels along the longitudinal direction upto which the metal shall be laid, shall be first obtained at site to the satisfaction of Engineer-in-Charge, and these shall be adhered to.

The surface of the aggregate spread shall be carefully trued up and all high or low spots remedied by removing or adding aggregate as may be required.

The W.B.M. sub-base shall be normally constructed in layer of 100 mm compacted thickness and W.B.M. base shall be normally constructed in layers of 75 mm compacted thickness. No segregation of large or fine particles shall be allowed and the coarse aggregate as spread shall be of uniform gradation with no pockets of fine material.

The coarse aggregate shall normally not be spread in lengths exceeding three days average work ahead of the rolling and blending of the proceeding section.

#### **16.7.7 Rolling**

Immediately following at spreading of the coarse aggregate, it shall be compacted to the full width by rolling with either the three- wheel- power -roller of 8 to 10 tonnes capacity or an equivalent vibratory roller. Initially, light rolling is to be done, which shall be discontinued when the aggregate is partially compacted with sufficient void space in them to permit application of screenings.

The rolling shall begin from the edges with the roller running forward and backward and adding the screenings simultaneously until the edges have been firmly compacted. The roller shall then progress gradually from the edges to the centre, parallel to the centre line of the road and overlapping uniformly each preceding rear wheel track by one half width and shall continue until the entire area of the course has been rolled by the rear wheel. Rolling shall continue until the road metal is thoroughly keyed with no creeping of metal ahead of the roller. Only slight sprinkling of water may be done during rolling, if required. On superelevated curves, the rolling shall proceed from the lower edge and progress gradually continuing towards the upper edge of the pavement.

Rolling of sub base shall not be done when the sub-grade is soft or yielding or when the rolling causes a wave like motion in the sub-base or sub-grade. When rolling develops irregularities that exceed 12 mm when tested with a three metre straight edge, the irregular surface shall be loosened and then aggregate added to or removed from it as required and the area rolled until it gives a uniform surface conforming to the desired cross-section and grade. The surface shall also be checked transversely by template for camber and any irregularities corrected in the manner described above. In no case shall the use of screenings to make up depressions be permitted.

### 16.7.8 Application of Screenings

After the coarse aggregate has been lightly rolled to the required true surface, screenings shall be applied gradually over the surface to completely fill the interstices. Dry rolling shall be continued while the screenings are being spread so that the jarring effect of the roller causes them to settle into the voids of the coarse aggregates. The screenings shall not be dumped in piles on the coarse aggregate but shall be spread uniformly in successive thin layers either by the spreading motion of the hand, shovels or a mechanical spreader.

The screenings shall be applied at a slow rate (in three or more applications) so as to ensure filling of all voids. Rolling and brooming shall continue with the spreading of the screenings. Either mechanical brooms or hand brooms or both may be used. In no case shall the screenings be applied, so fast and thick as to form cakes, ridges on the surface making the filling of voids difficult, or to prevent the direct bearing of the roller on the coarse aggregates. The spreading, rolling and brooming of screenings shall be performed on sections which can be completed within one day's operation and shall continue until no more screenings can be forced into the voids of the coarse aggregate. Damp and wet screenings shall not be used under any circumstances.

### 16.7.9 Sprinkling and Grouting

After spreading the screening and rolling the surface shall be copiously sprinkled with water, swept and rolled. Hand brooms shall be used to sweep the wet screening into the voids and to distribute them evenly. The sprinkling, sweeping and rolling operations shall be continued and additional screenings applied where necessary until the coarse aggregates are well bonded and firmly set for the entire depth and until a grout has been formed of screenings and water that will fill all voids and form a wave of grout ahead of the wheels of the roller. The quantity of water to be used during the construction shall not be excessive so as to cause damage to the sub-base or sub-grade.

### 16.7.10 Application of Binding Material

After the application of screenings and rolling, a suitable binding material shall be applied at a uniform and slow rate in two or more successive thin layers. After each application of binding material, the surface shall be copiously sprinkled with water and the resulting slurry swept in with hand brooms or mechanical brooms or both so as to fill the voids properly. The surface shall then be rolled by a 8-10 tonne roller, water being applied to the wheels in order to wash down the binding material that may get stuck to the wheels. The spreading of binding material, sprinkling of water, sweeping with brooms and rolling shall continue until the slurry that is formed will, after filling the voids form a wave ahead of wheels of the moving roller.

### 16.7.11 Setting and Drying

After final compaction of the course, the road shall be allowed to cure overnight. Next morning defective spots shall be filled with screenings or binding material, lightly sprinkled with water, if necessary and rolled. No traffic shall be allowed till the macadam sets.

### 16.7.12 Surface Evenness

The surface evenness of completed W.B.M. sub -base in the longitudinal and transverse directions shall be as specified in Table 16.14 for sub base with stone aggregate of size 90-45 mm and above.

TABLE 16.14

| Size of Coarse aggregates | Longitudinal profile measured with a 3 metre straight edge |   |       | Cross profile<br>Max. permissible undulation when measured with a camber template |
|---------------------------|--|---|-------|---|
|                           | Maximum permissible undulation                             | Max. No. of Undulations permitted in any 300 m length exceeding |       |   |
|                           |  | 15 mm   | 10 mm |   |
| 90-45 mm & above          | 15 mm  | -   | 30    | 12 mm   |

The longitudinal profile shall be checked using a 3 meter long straight edge and graduated wedge at the middle of each traffic lane along a line parallel to the Centre line of the road. The transverse profile shall be checked with adjustable template at intervals of 10 meters. For base with stone aggregate of size 63 to 45 mm and 53 to 22.4 mm surface evenness to be as per Table 16.15.

**TABLE 16.15**

| Size of Coarse aggregates | Longitudinal profile measured with a 3 metre straight edge |   |       | Cross profile  |
|---------------------------|--|---|-------|--|
|                           | Maximum permissible undulation                             | Max. No. of Undulations permitted in any 300 m length exceeding |       | Max. permissible undulation when measured with a camber template |
|                           |  | 15 mm   | 10 mm |  |
| 63-45 mm and 53-22.4 mm   | 12 mm  | -   | 30    | 8 mm   |

The longitudinal profile shall be checked with a three metre long straight edge and graduated wedge at the middle of each traffic lane along a line parallel to the centre line of the road. The transverse profile shall be checked with adjustable templates at intervals of 10 metres.

#### 16.7.13 Rectification of Defective Construction

Where the surface irregularity of the W.B.M. sub-base course exceeds the tolerances specified in Table 16.14 or where the course is otherwise defective due to sub grade soil mixing with the aggregates, the layer to its full thickness shall be scarified over the affected area, reshaped with added material or removal and replaced with fresh materials as applicable, and recompact. The area treated in the aforesaid manner shall not be less than 10 sqm. In no case shall depressions be filled up with screenings and binding materials.

#### 16.7.14 Measurements

The length and breadth shall be measured to the nearest centimetre. The depth of consolidated layer shall be computed to nearest half centimetre by taking average of depths at the centre and at 30 cm from the left and right edges at a cross section taken at 100 metre interval or less as decided by the Engineer-in-Charge by making small pits. The consolidated cubical contents shall be calculated in cubic metres correct to two places of decimal. The cubical contents shall be compared with net quantity of stone aggregates paid (that is stacked quantity – 7.5%). If the cubical contents are within ( $\pm$ ) 5% of the paid net stacked quantity of stone aggregates, the work shall be treated as acceptable. If the cubical contents is short of net stacked quantity by more than 5% then the payment shall be restricted to the quantities derived from cubical content.

#### 16.7.15 Rate

The rate shall include the cost of all labour and materials involved in all the operations described above, except cost of stone aggregate, kankar moorum, screenings and bajri, for which separate payments shall be made. Where W.B.M. is to be laid over an existing road, scarifying and consolidation of the aggregate received from scarifying shall be paid for separately.

### 16.8 WATER BOUND MACADAM WITH BRICK AGGREGATE (OVERBURNT (JHAMA) BRICK AGGREGATE)

**16.8.0** Over burnt (jhama) brick aggregate of size 120 mm to 40 mm or 90 mm to 45 mm is used. This is used when stone aggregate is costly and over burnt brick aggregate is available at reasonable rates. This is also used over soft clayey sub grade with high moisture contents and low CBR values.

#### 16.8.1 Quantities of Materials

Approximate quantity of brick aggregate (to be paid for separately) required to be stacked for 100 mm average compacted thickness of W.B.M. sub-base shall be 1.60 cum (approximate). The quantity of binding material, if required shall be as specified by the Engineer-in-Charge. Brick aggregate shall be broken from overburnt or well burnt brick bats. It shall be homogeneous in texture, roughly cubical in shape, clean and free from dirt and other foreign matter.

**16.8.2** Foundation shall be prepared as specified in 16.7.4.

**16.8.3** For spreading aggregate clause 16.7.6 shall apply except that the quantities of materials shall be as given above.

**16.8.4** The rolling shall be done as specified in 16.7.7 except that rolling shall be done with the light power roller. The use of screenings shall also be omitted. Rolling shall be done 3 to 5 times for each layer.

**16.8.5** For rolling with Binding material clause 16.7.10 shall apply except that rolling shall be done with a light power roller instead of a heavy road roller and water shall not be used during rolling. Rolling shall be done 3 to 5 times for each layer.

**16.8.6** Surface Evenness rectification of Defective construction, Measurements and Rate shall be as specified under 16.7.12 to 16.7.15.

## **16.9 BAJRI PATHS**

### **16.9.1 Preparation of Sub-Grade**

The formation for a width equal to that of the bajri path shall first be cut to a depth, below the proposed finished level, equal to the thickness of the course of brick aggregate (due allowance being made for consolidation) and dressed off in level to the finished profile.

In case of made up soil, adequate watering shall be done so that earth settles down as much as possible and the same rolled up with a minimum three tonnes or light power roller, as directed by the Engineer-in-Charge.

**16.9.2 Laying and Packing Brick Aggregate** : Shall be as specified in 16.7.6 except that brick aggregate shall be used instead of stone aggregate and laid to 7.5 cm depth unless specified otherwise.

**16.9.3 Consolidation** : Shall be as specified in 16.7.7 except that rolling shall be done by three tonnes or light power roller instead of by heavy road roller as directed by the Engineer-in-Charge.

**16.9.4 Rolling with Blinding Materials** : Shall be as specified in 16.7.10 except that rolling shall be done by three tonnes or light power roller instead of by heavy road roller as directed by the Engineer-in-Charge.

### **16.9.5 Measurements**

The finished work shall be measured between the kerb or channel stones or brick edging etc. as the case may be. Length and breadth shall be measured, correct to a cm. The area shall be calculated in square metres, correct to two places of decimal.

### **16.9.6 Rate**

The rate shall include the cost of materials and labour involved in all the operations described above.

## **16.10 BRICK EDGING**

### **16.10.1 Edging**

Trenches of specified width and depth shall first, be made along the edges of the wearing course of the road to receive the bricks. The bed of trenches shall be compacted to a firm and even surface and then the bricks shall be laid with its length at right angle or parallel to the side of the road depending upon the width of edging as specified in the item. The bricks shall be abutting against the wearing course, true to line, gradient and in camber with the finished road surface at the edge.



### **16.10.2 Finishing**

Berms and road edges shall be restored with excavated earth and consolidated by manually. All surplus earth including rubbish etc. shall be disposed off as directed by the Engineer-in-Charge.

### **16.10.3 Measurements**

Length of the finished work shall be measured in running metres along the edges of the road correct to a cm.

### **16.10.4 Rate**

The rate shall include the cost of materials and labour involved in all the operations described above.

## **16.11 SCARIFYING METALLED (WATER BOUND) SURFACE**

### **16.11.1 Scarifying**

All dirt, dust, cacked up mud, slush, animal droppings, vegetation and all other rubbish shall be removed from the water bound macadam surface.

The macadam surface shall be scarified to a depth of approximately 5 cm with such additional picking of high parts of the road as may be necessary to the required camber and gradient as directed by the Engineer- in-Charge. Any hollows that remain after picking shall be filled with new aggregate 50 mm nominal size and well consolidated to bring the surface to template.

### **16.11.2 Finishing**

The scarified aggregate shall be raked to bring smaller stones on the top and surface brought to the required camber and gradient with tolerance of 12 mm longitudinally as well as transversely.

All rubbish etc. shall be disposed off as directed by the Engineer-in-Charge. Scarifying operation will also include consolidation with road roller the aggregate received from scarifying, although this aggregate will be consolidated along with aggregate of new wearing course to be paid separately.

### **16.11.3 Measurements**

The finished work shall be measured between the kerb or channel stones or brick edging etc. as the case may be. Length and breadth shall be measured correct to a cm. The area shall be calculated in square metres correct to two places of decimal.

### **16.11.4 Rate**

The rate shall include the cost of labour and materials involved in all the operations described above except the cost of stone aggregate which shall be paid for separately.

## **16.12 DRY STONE PITCHING**

### **16.12.1 Stones**

These shall be clean, hard stones, free from decay and weathering. They shall be in block and hammer dressed on all sides.

The size of the pitching stones shall be approximately 22.5 cm.in depth and not less than 15 cm. in any other direction.

### **16.12.2 Preparation of surface**

The sides and bottom of earth work to be pitched, shall be brought to the required slope and gradient and shall be compacted to a firm and even surface.

### **16.12.3 Pitching**

Pitching shall be of 22.5 depth unless specified otherwise. Profiles shall be put up by means of pegs and strings or by placing stones, at intervals of not more than 15 cm. Stones shall then be laid closely in position in between the profile and firmly embedded with joints staggered and with exposed faces true to line, gradient and in uniform slope throughout.

Cross bands of approximately 22.5 cm. width through bond stones equal to the full depth of pitching shall be provided at an interval of approximately 3 metres centre to centre both longitudinally and transversely.

The interstices between adjacent stones shall be filled in with stones of proper size, well driven in with crow bars to ensure tight packing and complete filling of all interstices. Such filling shall be carried on simultaneously with the placing in position of the large stones and shall in no case be permitted to fall behind. Final wedging shall be done with the largest sized chip practicable, each chip being well driven home with a hammer so that no chip is possible of being picked up or removed by hand.

### **16.12.4 Measurements**

The measurements shall be taken in sqm. The area of pitching for drains shall be calculated by multiplying the perimeter (bed width plus side slopes) by the length of the pitching. The length, width and side slope shall be measured correct to a cm.

### **16.12.5 Rate**

The rate shall include the cost of the materials and labour involved in all the operations described above, except pitching stone, if specified, shall be paid for separately.

## **16.13 BRICK PITCHING**

**16.13.1** Bricks shall be all class designation 75 unless otherwise specified. The specification of bricks shall be as per SH 6.00 (Brick work) CPWD Specification – 2019.

### **16.13.2 Preparation of Surface**

The sides and bottom of earth work to be pitched, shall be brought to the required slope and gradients and shall be compacted to a firm and even surface.

### **16.13.3 Pitching**

Pitching shall be 10 cm. in depth or in multiples of 10 cm. as specified. Profiles shall first be put up by means of pegs and strings or by placing bricks at intervals not more than 15 cm. Bricks shall then be laid in parallel rows breaking bond or Herring –bone bond pattern as directed. In the case of drains, bricks shall be laid on bed width in parallel rows breaking bond and on sides in either of the above manner. At the top, the toe and at every 3 m. intervals, brick courses shall be laid with bricks on ends. All bricks shall be laid closely in position and firmly embedded, true to line, gradient and in uniform slope through out pitching work.

### **16.13.4 Measurements**

Para 16.12.4 shall apply, except that the measurements of the dry pitching 10 cm. deep for the drains shall be taken by adding 10 cm. on either side to the perimeter of the drain so as to allow for the top 20 cm. courses. In this case the perimeter of the drain (bed width plus sides slopes) plus 20 cm. multiplied with the length of the pitching shall give the area of the pitching in sqm.

### **16.13.5 Rate**

The rate shall include the cost of material and labour involved in all the operations described above.



## **16.14 CUTTING W.B.M. ROADS AND MAKING GOOD**

### **16.14.1 Cutting**

All road crossings shall be cut in half the width at a time and repaired, unless otherwise permitted by the Engineer-in-Charge. Cutting shall be straight and uniform in width. Soling stone and aggregate obtained from cutting macadam shall be stacked separately, clear of the road surface. Aggregate shall be screened. Stones of size below 20 mm and with rounded edges shall be discarded and disposed.

#### **16.14.1.2 Making Good**

**16.14.1.2.1** After the trenches have been filled in with excavated earth in layers of 15 cm thickness, watered, well consolidated with heavy iron rammers and brought to sub grade level, soling stone obtained from cutting shall be laid as per existing soling and consolidated with heavy iron rammers. Where the earth consolidation is well done, no settlement need occur subsequently, for this excess watering should be avoided.

**16.14.1.2.2** New aggregate 50 mm nominal size or as required, shall be added to old aggregate and spread over to a depth of 7.5 cm as specified in 16.7.6. This shall then be consolidated with hand roller or heavy iron rammers, as directed, first with light sprinkling then with sufficient application of water till the aggregate has become adequately consolidated and does not get displaced. All undulations shall be loosened by hand picking, surplus aggregate removed from high spots and depressions filled with surplus and new aggregate and the surface compacted again. When thoroughly consolidated, kankar moorum and red bajri, freshly collected shall be spread over it in 12 mm layer and consolidated with hand roller or heavy iron rammers, with sufficient application of sufficient water till a uniform surface is obtained.

**16.14.2.3** The finished surface shall be in camber and left a little higher than the adjoining road surface to allow for any settlement on drying.

**16.14.1.3 Measurement :** Length and width of cutting shall be measured correct to a cm. The area shall be calculated in square metre, correct to two places of decimal.

**16.14.1.4 Rate :** The rate shall include the cost of materials and labour involved in all the operations described above.

### **16.14.2 Cutting Bituminous Roads and Making Good**

**16.14.2.1** Cutting, making good and measurements shall be as specified in 16.14.1 except the top bituminous surface shall be finished as per the existing surface or as directed by the Engineer-in-Charge. The item shall include cutting and restoration of W.B.M. portion as well as Bitumen portion.

**16.14.2.2 Rate :** The rate shall include the cost of materials and labour involved in all the operations described above.

## **16.15 CUTTING BAJRI PATHS AND MAKING GOOD**

### **16.15.1 Cutting**

Cutting shall be straight and uniform in width. Brick aggregate obtained from cutting shall be screened, aggregates of smaller size discarded and disposed off and rest stacked clear off pathway.

#### **16.15.2 Making Good**

After the trench has been filled in with excavated earth, consolidated and brought to sub-grade level, brick aggregates obtained from cutting and mixed with new aggregates 50 mm nominal size, as required shall be spread to a depth of 7.5 cm as specified in 16.9.2. This shall then be consolidated with blinding materials and finished as specified in 16.14.1.2

### **16.15.3 Measurements**

Length and width of cutting shall be measured correct to a cm. The area shall be calculated in square metre correct to two places of decimal.

### **16.15.4 Rate**

The rate shall include the cost of materials and labour involved in all the operations described above.

## **16.16 FENCING WITH G.I. BARBED WIRE AND RCC POSTS (FIG. 16.9)**

### **16.16.1 Materials**

R.C.C. posts and struts shall be as specified in 16.1.12. G.I. Barbed wire shall be as per IS 278.

### **16.16.2 Spacing of Posts and Struts**

The spacing between posts shall be three metres centre to centre, unless otherwise specified, or as directed by the Engineer -in-Charge to suit the dimensions of the area to be fenced. Every 15th, last but one end post and corner posts shall be strutted on both sides and end posts on one side only.

### **16.16.3 Fixing of Posts and Struts**

Pits 45 x 45 cm and 75 cm deep or as directed shall first be excavated true to line and level to receive the posts. In the case of struts, pits 70 x 45 x 75 cm deep or as directed shall be excavated to suit the inclination of the strut so that it is surrounded by concrete by not less than 15 cm at any point. The pits shall be filled with a layer of 15 cm thick cement concrete 1:3:6 (1 cement: 3 fine sand: 6 graded stone aggregate 40 nominal size) . The posts and struts shall then be placed in the pits, the posts projecting 1.2 m or to the specified height above ground, true to line and position. The cement concrete 1:3:6 shall be filled in upto 15 cm for posts and 25 cm for struts below ground level at the base of the concrete so that the posts are embedded in the cement concrete block of size 45 x 45 x 60 cm and strut in block of size 70 x 45 x 50 cm. The concrete in foundations shall be watered for at least 7 days to ensure proper curing. The remaining portions of pits shall be filled up with excavated earth and the surplus earth disposed off as directed by the Engineer-in-Charge and site cleared.

### **16.16.4 Fixing G.I. Barbed Wire**

The barbed wire shall be stretched and fixed in specified number of rows and two diagonals. The bottom row shall be 14 cm above ground and the rest at 12.5 cm centre to centre. The diagonals shall be stretched between adjacent posts from top wire of one post to the bottom wire of the second post. The diagonal wires will be interwoven with horizontal wires by fixing the odd- rows of wires first , then the diagonal cross wires and lastly the even rows of wires. The barbed wire shall be held to the R.C.C. posts by means of G.I. staples fixed to wooden plugs or G.I. binding wire tied to 6 mm barnibis fixed while casting the posts. Turn buckles and straining bolts shall be used at the end posts, if so specified.

### **16.16.5 Measurements**

Total length of G.I. barbed wire shall be measured in running meter correct to a cm.

### **16.16.6 Rate**

The rate shall include the cost of labour and materials involved in all the operations described above but excluding the cost of posts, struts, turn buckle, straining bolts and excavation and concrete in foundations for which separate payments shall be made under respective items.

## **16.17 G.I. BARBED WIRE FENCING WITH ANGLE IRON POSTS**

### **16.17.1 Materials**

G.I. Barbed wire shall be as per IS 278 and angle iron shall be as per subhead – 10.00 steel work of CPWD Specification Vol. I- 2019. The angle shall be of size 40 x 40 x 6 mm.

### **16.17.2 Spacing of Posts and Struts**

The spacing of posts shall be 3.00 m centre to centre, unless otherwise specified or as directed by the Engineer-in-Charge to suit the dimensions of the area to be fenced. Every 15th, last but one end posts and corner post shall be strutted on both sides and end post on one side only.

### **16.17.3 Fixing of Posts and Struts**

This shall be as per 16.16.3. In addition, angle iron post at bottom shall be split and banded at right angle in opposite direction for 10 cm length to get proper grip.

### **16.17.4 Fixing G.I. Barbed Wire**

The barbed wire shall be stretched and fixed in specified number of rows and two diagonals. The bottom row should be 14 cm above ground and the rest at spacing of 2.5 cm centre to centre. The diagonal shall be stretched between adjacent posts from the top wire of one post to the bottom wire of 2nd post. The diagonal wire will be inter woven with horizontal wires by fixing the odd rows of wires first, then the diagonal cross wires and lastly even rows of wires. The barbed wire shall be held by tearing the holes of 10 mm dia in the post and tied with G.I. wire, turn buckles and straining bolts shall be used at the end post, if so specified.

### **16.17.5 Measurements**

This shall be as per 16.16.5.

### **16.17.6 Rates**

The rate shall include the cost of labour and materials involved in all the operations described above but excluding the cost of post struts turn buckle straining bolts and excavation and concrete in foundation for which separate payments shall be made under respective item. Angle iron post shall be paid as per similar item of subhead Steel work of CPWD Specification 2019 Vol-I. No extra payment shall be made for making holes in angle and nothing shall be deducted on account of holes.

## **16.18 WELDED STEEL WIRE FABRIC FENCING WITH RCC POSTS**

### **16.18.1 Materials**

RCC posts and struts shall be as specified in 16.1.12. Welded steel wire fabric will conform to IS 4948 and shall be of rectangular mesh 75 × 25 mm size weighing not less than 7.75 kg/sqm.

**16.18.2** Fixing of RCC posts and struts shall be as described in 16.16.3.

**16.18.3** Steel wire fabric 90 cm wide will be fixed to the posts by means of G.I. staple on wooden plugs or tied to 6 mm bar ribs with binding wire. The steel fabric shall be fixed to leave 15 cm clearance at the bottom and top of the posts.

### **16.18.4 Finishing**

The steel wire fabric shall be painted with two or more coats of approved shade of enamel paint over a coat of steel primer as for new work.

### **16.18.5 R.C.C. Posts, Rails and Pales (Fig. 16.10)**

**16.18.5.1 Materials :** R.C.C. posts, rails and pales shall be as described in 16.1.11 & 16.1.12.

**16.18.5.2 Spacing of Posts :** The spacing of post shall be as specified, or as directed by the Engineer-in-Charge to suit the dimensions of the area to be fenced.

**16.18.5.3 Fixing Posts :** Pits 45 x 45 cm and 70 cm deep or as directed shall first be excavated true to line and level to receive the posts.

**16.18.5.4 Fixing Rails and Pales :** The rails shall be slotted into the slots left in the posts, while the pales shall be simply dovetailed into the rails. The pales shall be fixed by pouring a little grout of 1.2 mix (1 cement : 2 fine sand) into the dovetails. The fencing shall be so erected that on completion is truly in line and level and top of the fence shall then follow approximately the profile of the ground.

**16.18.6 Measurements**

Fencing to be measured in square metre correct to two places of decimal after taking length and width of the finished work in metre.

**16.18.7 Rates**

As per item No. 16.16.6.

**16.19 ENGRAVING LETTERS IN HARD STONES (FIG. 16.5 & 16.6)**

**16.19.1 Size of Letters**

The letters shall be 13 cm, 10 cm or 8 cm high as per figure respectively.

**16.19.2 Engraving**

Engraving of the letters to the specified height and thickness shall be done by cutting with snap incision in V shape, about 12 mm deep or as directed by the Engineer-in-Charge.

**16.19.3 Finishing**

The engraved portion of the letters shall be painted with black enamel or as directed by the Engineer-in-Charge.

**16.19.4 Measurements**

The height of each letter shall be measured correct to a cm.

**16.19.5 Rate**

The rate shall include the cost of materials and labour involved in all the operations described above except the cost of stones and paint for lettering unless specified otherwise.

**16.20 BOUNDARY STONES (HARD STONE) (FIG. 16.4)**

**16.20.1** Boundary stones shall be as described in 16.1.21 or of size otherwise specified or directed by the Engineer-in-Charge.

**16.20.2 Spacing and Fixing**

The boundary stones shall be fixed as directed by Engineer-in -Charge at intervals of 200 m or less, where the boundary is in a curve or the land is costly and is likely to be encroached upon, and (ii) at all angular points of the road boundary.

The boundary stones shall be firmly fixed in ground to a depth of 60 cm and the side filling shall be thoroughly watered and consolidated.

The lower 60 cm portion of the boundary stones shall be encased on all sides by at least 15 cm of foundation concrete 1:5:10 (1 cement : 5 fine sand : 10 graded stone aggregate 40 mm nominal size) in case (a) where wet cultivation abuts the road land and boundary stones are likely to be displaced during agricultural operations (b) where the road runs in built up area, and (c) where the boundary stones are intended to serve as permanent land marks.

**16.20.3 Measurements & Rate**

Boundary stone shall be enumerated. The rate shall include the cost of materials and labour involved in all the operations described above.

### 16.21 PRECAST RCC BOUNDARY STONE (FIG. 16.4)

**16.21.1** RCC Boundary stones shall be manufactured as per standard design or as specified in item and directed by Engineer-in-Charge.

These shall be of reinforced cement concrete 1:1 ½ : 3 (1 cement : 1 ½ coarse sand : 3 graded stone aggregate 20 mm nominal size), 90 cm high and 15 cm dia at the top and 20 cm. dia at bottom with necessary steel reinforcement as per standard design or as directed by the Engineer-in-Charge. The precast RCC Stones shall be finished smooth with cement mortar 1:3 (1 cement : 3 fine sand).

**16.21.2** Spacing, fixing, measurements and rate shall be as described in 16.20.

### 16.22 KILOMETERS STONES (FIG. 16.7)

**16.22.0** Kilometer stone of precast RCC of grade 1: 1 ½ : 3 (1 cement : 1 ½ :3 coarse aggregate 20 mm nominal size ) of specified size to be used.

#### 16.22.1 Fixing

Trenches 50 cm wide and 45 cm deep shall first be excavated to receive the kilometer stone, the lower 45 portion of kilometer stone shall then be firmly fixed in position in ground and the sides filled with earth, thoroughly watered and consolidated.

Where so specified the kilometer stone shall be fixed in cement concrete 1:3:6 (1 cement : 3 fine sand : 6 graded stone aggregate 40 mm nominal size) so that there is 15 cm thick concrete in the bottom and 15 cm thick all round upto formation level. Trench excavation in this case will be made according to the requirements.

#### 16.22.2 Finishing

Precast RCC stone to be finished smooth in cement Mortar 1:3 (1 cement 3 fine sand). The exposed surfaces above ground shall be painted with two or more coats of required colour or as specified over a coat of primer as for new work, the background colour shall be white with black letters and numerals for names of stations and distances. The semi circular portions of kilometer stones on National Highways, State Highways and Major District Roads shall be painted canary yellow (I.S. shade 221) and white respectively. The route numbers to be written shall be in black on the canary yellow and white back grounds and in white on the brilliant green back grounds.

The place names shall be inscribed in different scripts in the order described in Table 16.16. Only one script shall be used on any one kilometer stone.

**TABLE 16.16**

| <b>Km. No.</b> | <b>Script</b>                                 |
|----------------|---|
| 0              | Roman   |
| 1              | Hindi (Devanagari Script)                     |
| 2              | Local Language                                |
| 3              | Hindi (Devanagari script)                     |
| 4              | Local Language                                |
| 5              | Roman<br>and so on repeated in the same order |

- (a) On kilometer stones fixed in other district roads and Village road the inscription may be in the National language i.e. Hindi in Devnagari script or the script of the recognised regional language of the place, at the discretion of the Local Road Authority.

- (b) Inscription in the Roman script is not necessary unless such a road leads to a place of tourist or archaeological interest.
- (c) The shape and spacing of letters in the Roman script other than Roman, the style of lettering shall be one in general use. The spacing between single or compound of lettering shall be the one in general use. The spacing between single or compound letter shall be atleast equal to the thickness of the vertical strokes or the thickness of strokes of letters in the scripts having no vertical strokes as in Oriya, Telegu and Kannada.
- (d) On the kilometre stones which are inscribed in script other than Roman, the style of lettering shall be one in general use. The spacing between single or computed of lettering shall be the one in general use. The spacing between single of letters in the scripts having no vertical strokes as in Oriya, Telegu and Kannada.

### **16.22.3 Measurements**

Kilometer stones shall be enumerated.

### **16.22.4 Rate**

The rate shall include the cost of materials and labour involved in all the operations described above, but excluding the costs of excavation, concrete in foundations painting and lettering for which payment shall be made separately.

### **16.23 SURFACE DRESSING ON NEW SURFACE WITH HOT BITUMEN OF GRADE VG- 10 ONE COAT**

**16.23.0** This type of treatment shall consist of cleaning the existing water bound macadam kankar or gravel surfaces, and applying one coat of hot bitumen of grade VG- 10 of approved quality using 2.25 kg of bitumen per sqm with 1.65 cum of stone chippings 13.2 mm nominal size per 100 sqm of road surface on the prepared base, blinding it with stone chippings of 13.2 mm nominal size and consolidation with a road roller of 6 to 8 tonne capacity. This type of treatment is normally done for a road with light density rubber tyred traffic and roads for temporary construction. This treatment is also done on existing water bound macadam before applying the final surface treatment. In the latter case, after applying a coat of painting the road is thrown open to traffic till the road is consolidated. The final treatment is then given after making good the undulations etc. in the road surface.

**16.23.1** Preparation of surface (Repairs and Cleaning) shall be as specified under 16.24.2(a).

**16.23.2** Applying binder, blinding, consolidation, surface finishing, measurements and rates shall be as specified under 16.24 except that binder shall be applied at the rate of 2.25 kg of bitumen per sqm and stone chippings of size 13.2 mm at 1.65 cum per 100 sqm unless otherwise specified.

### **16.24 SURFACE DRESSING ON NEW SURFACE USING HOT BITUMEN OF GRADE VG- 10 —TWO COATS**

**16.24.0** This consists of the application of two coats of surface dressing each coat consisting of a layer of bituminous binder sprayed on a base prepared previously, followed by a cover of stone chippings properly rolled to form a wearing course. The existing water-bound macadam, kankar or gravel surface shall be cleaned thoroughly before application of bituminous binder. The work shall be carried out only when the atmospheric temperature in shade is 16 deg C or above. No bituminous material shall normally be applied when the road surface or material is damp, when the weather is foggy or rainy, or during dust storms.

#### **16.24.1 Materials**

Binder i.e. bitumen of grade VG- 10 confirming to IS : 73 shall be as specified and shall conform to Table 16.7 and stone chippings shall conform to grading as the Table 16.17. Unless otherwise specified or directed by the Engineer -in- Charge the quantities of materials shall be as specified in Table 16.17. A proper record will be kept to ensure that the daily out-turn of work is co-related with the quantity of bitumen used as per proforma given in Appendix 'A'.



**TABLE 16.17**

| Type of coat | Stone Chipping |  |                                 | Bitumen Quantity VG- 10        |
|--------------|----------------|--|---------------------------------|--------------------------------|
|              | Nominal Size   | Specification  | Quantity                        |                                |
| First Coat   | 13.2 mm        | 100 per cent passing through IS sieve 22.4 mm square mesh and retained on IS Sieve 11.2 mm square mesh | 1.5 cum/100 sqm of road surface | 1.8 kg per sqm of road surface |
| Second coat  | 11.2 mm        | 100 per cent passing through IS sieve 13.2 mm square mesh and retained on IS sieve 5.6 mm square mesh  | 1.0 cum/100 sqm of road surface | 1.1 kg per sqm of road surface |

**16.24.2 First Coat****(a) Preparation of Surface**

*Repairs* : Pot holes or patches and ruts in the water bound macadam base or surface course which is to be surface treated, shall be repaired by removal of all loose and defective material by cutting in rectangular patches and replacement with suitable material.

For the purpose of repairs the area of pot holes shall be taken upto 0.75 sqm and depth upto 5 cm. All pot holes, patches and ruts upto 2.5 cm deep shall be repaired and brought to level with premix and properly consolidated while those of depths greater than 2.5 cm shall be repaired with similar specifications as adopted originally.

*Cleaning* : Prior to the application of the binder, all dust, dirt, caked mud, animal dung, loose and foreign material etc. shall be removed 30 cm on either side, beyond the full width to be treated, by means of mechanical sweepers and blowers, if available or otherwise with wire brushes, small picks, brooms etc. The material so removed shall be disposed off as directed by the Engineer-in-Charge.

For a water bound macadam surface, the interstices between the road metal shall be exposed upto a depth of about 10 mm by means of wire brushes. The surface shall then be brushed with soft brooms to remove all loose aggregate. Finally the traces of fine dust which get accumulated while brushing shall be thoroughly removed from the surface by blowing with gunny bags.

The prepared surface shall be closed to traffic and maintained fully clean till the binder is applied.

**(b) Applying Binder (Hot Bitumen) VG- 10 (confirming to IS : 73)**

The binder shall be heated in a boiler to a temperature as specified under Table 16.7 for the grade used and maintained at the temperature, the use of a thermometer being essential.

The binder shall be applied evenly to the clean dry surface by means of a pressure sprayer at the rate specified. The binder shall be applied longitudinally along the length of the road and never across it. The edges of the binder surface shall be defined by wire or a rope stretched in position.

Heating in cut out drums and pouring from perforated tins, cans and such other methods shall not be permitted. Except in the case of petty works and repairs with the specific approval of the Engineer-in-Charge.

Excessive deposits of binder caused by stopping or starting of the sprayer or through leakage or any other reason shall be suitably corrected before the stone chippings are spread.

**(c) Blinding or Spreading Stone Chippings**

Immediately after the binder is applied and while it is still hot, stone chippings free from dust and in a dry and clean state shall be spread evenly over the surface at the rate specified above. Spreading shall be done preferably by means of a mechanical gritter, otherwise manually with a twisting motion to avoid segregation which otherwise shall have to be removed by brushing the excess stone chippings over the surface into hungry spots to obtain a uniform surface, free from waviness, depressions and other irregularities. The surface shall be checked by means of a camber board laid across the road and a three metre straight edge laid parallel to the centre line of the road, and undulations if any shall be corrected by addition or removal of blindage till a surface free from undulation is obtained.

If a uniform surface is assured at this stage, the completed surface should be normally free from undulations and unevenness.

**(d) Consolidation of Blindage**

Immediately following the application of the stone chippings and light brooming, the road surface shall be compacted by a power roller of 6 to 8 tonnes, starting at edges and working towards the centre (or to the outside edge in case of superelevated curve). Each pass of the roller shall uniformly overlap not less than one third of the track made in the preceding pass. The roller shall be worked or started and stopped without jerks and shall not be stopped or reversed each time at the same location to cause displacement of stone and other irregularities. Consolidation shall be considered complete when the stone chippings are firmly embedded.

Generally five to six trips shall be made for thorough compaction of the surface or as may be specified by the Engineer-in-Charge.

Along kerbs, manholes and all places not accessible to the roller, compaction shall be secured by means of steel rammers or hand rollers.

**16.24.3 Second Coat**

- (a) **Cleaning the Road Surface** : The surface shall be examined and any loose material and foreign matter shall be removed by brooming or blowing off by fanning with gunny bags, care being taken not to loosen the blindage already set.
- (b) **Applying Binder (Hot Bitumen of Grade VG- 10)** : The second coat of binder shall be applied immediately after the blinding has been set and the surface has been cleaned. The binder shall be applied at the specified rate in the manner specified for the first coat 16.24.2(b).
- (c) **Blinding or Spreading Stone Chippings** : Immediately after the second application of binder, the stone chippings shall be spread at the rate specified as above in the manner described in 16.24.2(c).
- (d) **Consolidation of Blindage** : The specifications described in 16.24.2(d) shall apply. Further the prepared finished surface shall be protected from traffic for 24 hours or such period as may be specified by the Engineer-in-Charge.

**16.24.4 Surface Finishing**

The finished surface shall be uniform and conform to the lines, grades and typical cross-sections shown in the drawings.

**16.24.5** The finished surface shall be thrown open to traffic on the following day. Controlling traffic shall be done by suitable methods like barricading posting of watchman etc.



#### **16.24.6 Measurements**

The length and width of the finished work shall be measured correct to a cm along the finished surface of the road. The area shall be calculated in square metre, correct to two places of decimal.

For record purposes, the measurement for binder and stone chippings shall be taken as specified in 16.4.2 and 16.4.3 before they are actually used on the work. Premeasurements of materials taken for record purposes shall simply serve as a guide and shall not form the basis for payment.

#### **16.24.7 Rate**

The rate shall include the cost of materials and labour involved in all the operations described above, except for repairs described under 16.24.2.

#### **16.25 SURFACE DRESSING ON OLD SURFACE WITH HOT BITUMEN OF GRADE VG- 10 (CONFIRMING TO IS : 73) ONE COAT**

**16.25.0** This treatment consists of cleaning old painted surfaces and applying a coat of hot bitumen of grade VG- 10 on the prepared base, blinding with stone chippings and consolidation with road roller of 6 to 8 tonne capacity.

##### **16.25.1 Materials**

Binder shall be as specified and conform to Table 16.7 stone chipping shall conform to grading given Table 16.17 for 11.2 mm. Unless otherwise specified or directed by the Engineer-in-Charge stone Chippings of 11.2 mm nominal size shall be used @ 1.50 cum per 100 sqm area and bitumen @ 1.95 kg per square metre area. A proper record shall be kept to ensure that the daily turn out of work is correlated with the quantity of bitumen used as per proforma given in Appendix 'A'.

**16.25.2** Preparation of Surface (Repairs and cleaning) shall be as specified under 16.24.2.

**16.25.3** Applying binder, Blinding, Consolidation, Surface Finishing, Measurement and Rate shall be as specified under 16.24 except that the binder and chippings shall be applied at the rate specified above.

#### **16.26 SURFACE DRESSING ON NEW SURFACE WITH BITUMEN EMULSION (MINIMUM 50% BITUMEN CONTENT RS GRADE CONFIRMING TO IS : 8887) ONE COAT**

**16.26.0** This treatment consists of cleaning the existing water bound macadam, kankar gravel or stabilized base and other black top surfaces, applying a coat of bitumen emulsion at atmospheric temperature, blinding it with stone chippings including consolidation with a road roller.

This type of treatment is normally applied under damp conditions and for minor repair works during rainy season for roads with medium density, rubber tyred traffic such as service roads. This treatment is also done on existing water bound macadam before applying the final surface treatment. In the latter case, the road is consolidated. The final treatment is then given after making good the undulations depressions etc. in the road surface.

##### **16.26.1 Materials**

Binder shall be as specified and shall conform to RS grade confirming to IS : 8887. Stone chipping of 13.2 mm size shall conform to Table 16.17. Unless otherwise specified or directed by the Engineer-in-Charge 13.2 mm stone chippings shall be used @ 1.5 cum per 100 sqm area and bitumen @ 1.95 kg/sqm area. A proper record shall be kept to ensure that the daily out turn of work is correlated with the quantity of bitumen used as per proforma given in Appendix 'A' .

##### **16.26.2 Preparation of Surface**

The specification described in 16.24.2 (a) shall apply except that the binder used for patch repairs etc. shall be bitumen emulsion.

### **16.26.3 Applying Binder**

The specification described in 16.24.2 (b) shall apply except that bitumen emulsion is not heated in boilers but it shall be spread at atmospheric temperature at the specified rate. In case the road surface is very dry the surface shall be very lightly sprinkled with water just before applying the binder.

**16.26.4** Blinding including consolidation, Measurements and Rate shall be as specified under 16.24 except that the stone chippings shall be spread at the specified rate immediately after the bitumen emulsion on application breaks i.e. changes colour from brown to black.

### **16.27 SURFACE DRESSING ON OLD SURFACE WITH BITUMEN EMULSION (MINIMUM 50% BITUMEN CONTENT RS GRADE CONFIRMING TO IS : 8887) ONE COAT**

**16.27.0** This treatment consists of cleaning old painted surfaces and applying a coat of bitumen emulsion on the prepared base, blinding with stone chippings and consolidation with a road roller. This type of treatment is normally done under damp conditions.

#### **16.27.1 Materials**

Binder shall be as specified and shall conform to RS grade confirming to IS : 8887. Unless otherwise specified or directed by the Engineer- in-Charge 11.2 mm the stone chippings shall be used @ 1.10 cum per 100 sqm area and bitumen @ 1.22 kg per sqm area. A proper record shall be kept to ensure that the daily out turn of work is correlated with the quantity of bitumen used as per proforma given in Appendix 'A'.

**16.27.2** Preparation of surface shall be as specified in 16.24.2 (a) except that the binder used for patch repairs etc. shall be bitumen emulsion.

**16.27.3** Applying binder, bitumen emulsion, blinding or Spreading to it including consolidation of blindage, measurement etc. shall be as specified under 16.24 except for preparation of surface and that the binder and stone chippings shall be used at the rates prescribed in 16.26.1.

### **16.28 TACK COAT OF HOT STRAIGHT RUN BITUMEN OF GRADE VG- 10**

**16.28.0** The rate of application of binder which shall be as specified and which shall conform to 16.1.5 shall depend on the surface on which the premix carpet is to be laid.

(a) 0.75 kg/sqm on W.B.M./ W.M.M. Surface

(b) 0.50 kg/sqm on bitumen surface.

#### **16.28.1 Materials**

**Bitumen** : This shall be straight-run bitumen of grade VG- 10 conforming to IS 73 specifications.

#### **16.28.2 Preparation of Surface**

#### **16.28.3 Cleaning**

Prior to the application of bitumen, all vegetation, loose sealing compound, caked mud, animal dung, dust, dirt and foreign material shall be removed from the entire surface of the pavement and from existing dummy, construction and expansion joints (wherever existing) by means of mechanical sweepers and blowers, otherwise with steel wire brushes, small picks, brooms or other implements as approved by the Engineer-in-Charge. The material so removed shall be disposed off as directed by the Engineer-in-Charge.

#### **16.28.4 Weather and Seasonal Limitations**

The tack coat shall not be applied nor any bitumen work done during rainy weather or when the surface is damp or wet or when the atmospheric temperature in the shade is not more than 16° C.

### **16.28.5 Application of Tack Coat**

**16.28.5.1 Heating :** Bitumen shall be heated in a boiler to a temperature of 165 deg. C to 175 deg. C and maintained at that temperature. Temperature shall be checked at regular intervals with the help of a thermometer.

**16.28.5.2 Application of Bitumen :** Hot bitumen shall be applied evenly to the clean, dry surface by means of a pressure sprayer at specified rate. Even and uniform distribution of bitumen shall be ensured. Bitumen shall be applied longitudinally along the length of the pavement and never across it. Excessive deposits of bitumen caused by stopping or starting of the sprayer or through leakage or any other reason shall be suitably rectified.

### **16.28.6 Measurements**

Length and breadth shall be measured correct to a cm, along the surface of pavement. Area shall be worked out in sqm correct to two places of decimal.

### **16.28.7 Rate**

Rate shall include the cost of all materials and labour involved in all the operations described above.

## **16.29 TACK COAT WITH BITUMEN - EMULSION/ HOT BITUMEN OF GRADE VG– 10**

### **16.29.1 Scope**

The work shall consist of the application of single coat of low viscosity liquid bituminous material to existing bituminous, cement concrete or primed granular surface preparatory to the superimposition of a bituminous mix, as specified in the contract or as instructed by the Engineer-in-Charge and applied as specified in the nomenclature of item.

### **16.29.2 Materials**

The binder used for tack coat shall be either cationic bitumen emulsion (RS1) complying with IS:8887 or suitable low viscosity paving bitumen of VG 10 grade conforming to IS:73. The use of cutback bitumen RC:70 as per IS:217 shall be restricted only for sites at sub-zero temperatures or for emergency applications as directed by the Engineer-in-Charge. The type and grade of binder for tack coat shall be as specified in the contract or as directed by the Engineer-in-Charge.

### **16.29.3 Construction**

#### **16.29.3.1 Equipment**

The tack shall be applied by a self propelled or towed bitumen pressure sprayer, equipped for spraying the material uniformly at specified rate. Hand spraying shall not be permitted except in small areas, inaccessible to the distributor, or narrow strips, shall be sprayed with a pressure hand sprayer, or as directed by the Engineer-in-Charge.

#### **16.29.3.2 Preparation of Base**

The surface on which the tack coat is to be applied shall be clean and free from dust, dirt and any extraneous material, and be otherwise prepared in accordance with the requirements. The granular or stabilized surfaces shall be primed as per **Para 16.65** clause (priming coat) immediately before the application of the tack coat, the surface shall be swept clean with a mechanical broom, and high pressure air jet, or by other means as directed by the Engineer-in-Charge.

#### **16.29.3.3 Application of Tack Coat**

The application of tack coat shall be at the rate specified in **Table 16.17A** and it shall be applied uniformly. If rate of application of tack coat is not specified in the contract, then it shall be the rate specified in **Table 16.17A**. No dilution or heating at site RS1 bitumen emulsion shall be permitted. Paving bitumen if use for tack coat shall be heated to appropriate temperature in bitumen boilers to achieve viscosity less than 2 poise. The normal range of spraying temperature for a bituminous emulsion shall be 20 C to 70 C and for cutback, 50 C to 80 C. The method of application of tack coat will depend on the type of equipment to be used, size of nozzles, pressure at the spray bar and speed or forward movement. The contractor shall demonstrate at a spraying trial, that the equipment and method to be used is capable of producing a uniform spray, within the tolerances specified.

**Table 16.17A**  
**Rate of application of tack coat**

| <b>Type of Surface</b>                | <b>Rate of Spray of Binder in Kg per sq.m</b> |
|---------------------------------------|---|
| Bituminous surfaces                   | 0.20-0.30                                     |
| Granular surfaces treated with primer | 0.25-0.30                                     |
| Cement concrete pavement              | 0.30-0.35                                     |

**16.29.3.4 Curing of Tack Coat**

The tack coat shall be left to cure until all the volatiles have evaporated before any subsequent construction is started. No plant or vehicles shall be allowed on the tack coat other than those essential for the construction.

**16.29.4 Measurement of Payment**

Tack coat shall be measured in terms of surface area of application in square metres.

**16.29.5 Rate**

The contract unit rate for tack coat shall be payment in full for carrying out the required operations including for all components i.e. labour, equipments and machinery as described above.

**16.30 PREMIX CARPET WITH HOT BITUMEN OF PAVING ASPHALT GRADE VG- 10/ VG-30**

**16.30.0** This type of treatment is normally applied on roads where the motor traffic is of medium intensity, but bullock cart traffic is fairly heavy. This treatment is suitable for district roads and for internal and service road in colonies. The consolidated thickness of this type of treatment shall be 2 cm or 2.5 cm as specified.

This treatment consists of applying a tack coat on the prepared base followed immediately by spreading aggregates pre-coated with specified binder to camber and consolidated.

Premix carpet shall not be laid during rainy weather or when the base course is damp or wet or, when the atmospheric temperature in the shade is not more than 16°C.

**16.30.1 Preparation of Surface**

This shall be done as described in 16.26.

**16.30.2 Materials**

Grading of stone chipping shall be as per Table 16.17. Binder shall be as specified in nomenclature of item and shall conform to Table 16.7. Quantities of materials shall be as given in Table 16.18. A proper record shall be kept to ensure that the daily out turn of work is correlated with the quantity of bitumen used as per proforma given in Appendix 'A'.

**TABLE 16.18**

| Consolidated thickness of premix carpet | Binder Hot Bitumen of grade VG- 10/ VG- 30 (kg/ cum of stone chipping) | Stone Chippings (in cum/ 100 sqm) |              |
|---|--|-----------------------------------|--------------|
|   |  | 13.2 mm size                      | 11.2 mm size |
| 2.00 cm                                 | (52 kg/cum of 13.2 mm size and 56 kg per cum of 11.2 mm                | 1.8                               | 0.90         |
| 2.50 cm                                 | -Do-   | 2.25                              | 1.12         |

### **16.30.3 Tack Coat**

The rate of application of binder for tack coat shall be as specified in the nomenclature of item. The rate will be depending upon the surface on which the premix carpet is to be laid i.e. water bound macadam surface or existing black topped surface. Tack coat shall be applied as described in 16.28.

### **16.30.4 Preparation of Premix**

The aggregate shall be dry and suitably heated to temperature as directed by Engineer-in-Charge before these are placed in the mixer to facilitate mixing with the binder.

Mixers of approved type shall be employed for mixing the aggregates with the bituminous binder.

The binder shall be heated to the temperature appropriate to the grade of bitumen approved by the Engineer-in-Charge, in boilers of suitable design avoiding local overheating and ensuring a continuous supply.

The aggregates shall be dry and suitably heated to a temperature as directed by Engineer-in-Charge before these are placed in the mixer. After about 15 seconds of dry mixing, the heated binder shall be distributed over the aggregates at the rate specified.

The mixing of binder with chippings shall be continued until the chippings are thoroughly coated with the binder. The mix shall be immediately transported from the mixer to the point of use in suitable vehicles or wheel barrows. The vehicles employed for transport shall be cleaned and be covered over in transit if so directed.

### **16.30.5 Spreading and Rolling**

The premixed material shall be spread on the road surface with rakes to the required thickness and camber or distributed evenly with the help of a drag spreader, without undue loss of time. The camber shall be checked by means of camber boards and inequalities evened out. As soon as sufficient length of bituminous material has been laid, rolling shall commence with 6 to 9 tonne power rollers, preferably of smooth wheel tandem type, or other approved power roller. Rolling shall begin at the edges and progress towards the centre longitudinally. Except on the super elevated portions rolling shall progress from the lower to upper edge, parallel to the centre line of the pavement. The consolidated thickness shall not at any place be less than the specified thickness by more than 25%. However, the average thickness shall not be less than that specified in the item.

When the roller has passed over the whole area once, any high spots or depressions which become apparent shall be corrected by removing or adding premixed materials. Rolling shall then be continued until the entire surface has been rolled to compaction and all the roller marks eliminated. In each pass of the roller, preceding track shall be overlapped uniformly by at least 1/3 width. The roller wheels shall be kept damp to prevent the premix from adhering to the wheels and being picked up. In no case shall fuel/lubricating oil be used for this purpose.

Rollers shall not stand on newly laid material as it may get deformed thereby.

The edges along and transverse of the carpet, laid and compacted earlier shall be cut to their full depth so as to expose fresh surface which shall be painted with a thin surface coat of appropriate binder before the new mix is placed against it.

Further, the prepared finished surface shall be protected from traffic for 24 hours or such period as may be directed by the Engineer-in-Charge.

### 16.30.6 Surface Finishing

The surface regularity both in longitudinal and transverse directions shall be within the tolerances specified in Table 16.19.

**TABLE 16.19**

| Longitudinal profile Max. permissible undulation when measured with 3 M straight edge | Cross profile Max. permissible variation from specified profile when measured with a camber template |
|---|--|
| 10 mm   | 6 mm   |

The longitudinal profile shall be checked during rolling with a three metres long straight edge and graduated wedge at the middle of each traffic lane along the road. Similarly the transverse profile shall be checked with adjustable templates at intervals of 10 metres.

### 16.30.7 Rectification

Where the surface irregularity fall outside the specified tolerances limit the contractor shall be liable to rectify it to the satisfaction of Engineer-in-Charge by adding fresh material and recompacting to specifications where the surface is low. Where the surface is high the full depth of the layer shall be removed and replaced with fresh material and compacted to specifications.

### 16.30.8 Measurements

The length and width of the finished work shall be measured correct to a cm along the finished surface of the road. The area shall be calculated in square metre, correct to two places of decimal.

For record purposes, the measurement for binder and stone chippings shall be taken as specified in 16.4.2.2 and 16.4.3.2 before they are actually used on the work. Premeasurements of the materials taken for record purposes shall simply serve as a guide and shall not form the basis for payment.

### 16.30.9 Rate

The rate shall include the cost of materials, machinery and labour involved in all the operations described above for the particular item, except for the cost of Repairs described under para 16.24.2(a).

## 16.31 PREMIX CARPET WITH BITUMEN EMULSION

**16.31.0** This type of work is not ordinarily recommended but may be done in case of urgent repairs under damp conditions.

### 16.31.1 Materials

Binder shall be as specified and shall conform to RS grade as per IS 8837 grading of 11.2 mm stone chipping shall be as per Table 16.17. Quantities of bitumen emulsion and stone chippings shall be as specified in Table 16.20. A proper record shall be kept to ensure that the daily out turn of work is corre-lated with the quantity of bitumen used as per proforma given in Appendix 'A'.

**TABLE 16.20**  
**Bitumen Emulsion**

| Consolidated thickness of premix Carpet | Bitumen Emulsion (medium setting minimum 65% bitumen content) | Stone Chippings            |
|---|---|----------------------------|
|   | For Carpet in kg/cum of chippings                             | cum per 100 sqm            |
| 2 cm                                    | 96  | 2.4 (11.2 mm nominal size) |
| 2.5 cm                                  | 96  | 3.0 (11.2 mm nominal size) |



**16.31.2** Preparation of surface and binder application shall be as specified under 16.26 except that the rate of application of bitumen for tack coat shall be 0.75 kg per sqm on water bound macadam surface and 0.5 kg per sqm on black topped surface.

**16.31.3** Preparation, spreading, consolidating mix, surface finishing, measurements and rate shall be as specified under 16.30 except that the bitumen emulsion shall not be heated but it shall be poured over the aggregate at atmospheric temperature at the correct rate before spreading on the road surface. The rolling with road roller of 6 to 9 tone capacity shall commence 24 hours after spreading the mixture. The surface shall be protected by a suitable device such as barricading and posting of watchmen for closing the traffic.

## **16.32 BITUMINOUS PENETRATION MACADAM**

### **16.32.0 Scope**

The work shall consist of construction of one or more layers of compacted crushed coarse aggregates with alternate applications or bituminous binder and key aggregates in accordance with the requirements of these specifications to be used as a base course on roads, subject to the requirements of the overall pavement design, in conformity with the lines, grades and cross-sections shown on the drawings or as directed by the Engineer-in-Charge. Thickness of an individual course shall be 50 mm or 75 mm or otherwise as specified.

### **16.32.1 Materials**

**16.32.1.1 Bitumen :** The binder shall be paving bitumen of specified penetration grade conforming to IS 73 or approved cutback satisfying the requirement of IS 217 or 454 as specified in item. The actual grade of bitumen or cutback to be used shall be as specified in item or as directed by the Engineer-in-charge.

**16.32.1.2 Aggregates:** The coarse aggregates shall consist of crushed rock, crushed gravel or other hard material retained on the 2.36 mm IS sieve. They shall be clean, hard, durable, of cubical shape, free from dust and soft or friable matter, organic or other deleterious matter. Where the contractors selected source of aggregate have poor affinity for bitumen, as a condition for approval of the source, the bitumen shall be treated with approved anti-stripping agents, as per the manufacturers recommendations, without additional payment. Before approval of the source the aggregate shall be tested for stripping. The coarse aggregate shall conforming to Table 16.31. The coarse and key aggregates shall conform to the grading given in Table 16.21.

**16.32.1.3 Quantities of Material :** The quantities of materials used for this work shall be as specified in Table 16.21.

### **16.32.2 Construction Operations**

**16.32.2.1 Weather and Seasonal Limitations:** Laying shall be suspended while free standing water is present on the surface to be covered, or during rains, fog and dust storm. After rain, the bituminous surface, tack coat shall be blown off with a high pressure of air jet to remove excess moisture, or the surface left to dry before laying shall start. Laying of bituminous mixture shall not be carried out when the air temperature at the surface on which it is to be laid is below 10°C.

**16.32.2.2 Equipment :** A mechanical broom, compressor, self propelled or trailed bitumen heater/distributor, mechanical aggregate spreader and 8 to 10 tonne smooth steel wheel roller or vibrating roller are required for the preparation of Penetration Macadam.

**16.32.2.3 Preparation of the Base :** The base on which the Penetration Macadam Course is to be laid shall be prepaid, shaped and compacted to the specified lines, grades and sections as appropriate or directed by Engineer-in-Charge. A prime coat, where specified shall be applied over the base as directed by the Engineer-in-charge.

**16.32.2.4 Spreading Coarse Aggregate :** The coarse aggregate shall be dry and clean and free from dust, and shall be spread uniformly and evenly at the rate specified in Table 16.21. It shall be spread by a self-propelled or tripper tail mounted aggregate spreader capable of spreading aggregate uniformly at the specified rates over the required widths. The surface of the layer shall be carefully checked with camber templates to ensure correct line and level and cross fall. The spreading shall be carried out such that the rolling and penetrating operations can be completed on the same day. Segregated aggregates or aggregates contaminated with foreign material shall be removed and replaced.

**TABLE 16.21  
Composition of Penetration Macadam**

| IS Sieve Designation (mm)  | Cumulative percent by weight of total aggregate passing |               |                            |               |
|--|---|---------------|----------------------------|---------------|
|  | For 50 mm compacted Thickness                           |               | For 75 compacted Thickness |               |
|  | Coarse Aggregate  | Key Aggregate | Coarse Aggregate           | Key Aggregate |
| (1)  | (2)   | (3)           | (4)                        | (5)           |
| 63   | -   | -             | 100                        | -             |
| 45   | 100   | -             | 58-82                      | -             |
| 26.5   | 37-72   | -             | -                          | 100           |
| 22.4   | -   | 100           | 5-27                       | 50-75         |
| 13.2   | 2-20  | 50-75         | -                          | -             |
| 11.2   | -   | -             | -                          | 5-25          |
| 5.6  | -   | 5-25          | -                          | -             |
| 2.8  | 0-5   | 0-5           | 0-5                        | 0-5           |
| Approx. Loose Aggregate quantities cm/m <sup>2</sup>                     | 0-06  | 0.015         | 0.09                       | 0.018         |
| Binder Quantity (Penetration Grade) <sup>(1)</sup> (Kg./m <sup>2</sup> ) | As specified in item                                    |               | As specified in item       |               |

**Note :** (1) If cutback bitumen is used, adjust binder quantity such that the residual bitumen is equal to the values in this table.

**16.32.2.5 Compaction :** After the spreading of course aggregates, dry rolling shall be carried out with an 8-10 tonne smooth steel wheel roller. After initial dry rolling the surface shall be checked with a crown and 3 metre straight edge. The surface shall not vary more than 10 mm from the template or straight edge. All surface irregularities exceeding the above limit shall be corrected by removing or adding aggregate as required the rolling shall continue until the compacted coarse aggregate has a firm surface, true to cross-section shown on the plans and has a texture that will allow free and uniform penetration of the bitumen material.

Compaction shall be done as per following procedure.

Bituminous materials shall be laid and compacted in layers which enable the specified thickness, surface level, regularity requirements and compaction to be achieved.

Compaction of bituminous materials shall commence as soon as possible after laying. Compaction shall be substantially completed before the temperature falls below the minimum rolling temperatures stated in the relevant part of these specifications. Rolling of the longitudinal joints shall be done immediately behind the paving operation. After this, rolling shall commence at the edges and progress towards the centre longitudinally except that on super elevated and uni-directional cambered portions, it shall progress from the lower to the upper edge parallel to the centre line of the pavement. Rolling



shall continue until all roller marks have been removed from the surface. All deficiencies in the surface after laying shall be made good by the attendants behind the paver, before initial rolling is commenced. The initial or breakdown rolling shall be done with 8-10 tonnes dead weight smooth-wheeled rollers. The intermediate rolling shall be done with 8-10 tonnes dead weight or vibratory roller or with a pneumatic tyred roller of 12 to 15 tonnes weight having nine wheels, with a type pressure of at least 5.6 kg/sqcm. The finish rolling shall be done with 6 to 8 tonnes smooth wheeled tandem rollers.

Where compaction is to be determined by density of cores the requirements to prove the performance of rollers shall apply in order to demonstrate that the specified density can be achieved. In such cases the Contractor shall nominate the plant, and the method by which he intends to achieve the specified level of compaction and finish at temperature above the minimum specified rolling temperature. Laying trials shall then demonstrate the acceptability of the plant and method used.

Bituminous materials shall be rolled in a longitudinal direction, with the driven rolls nearest the paver. The roller shall first compact material adjacent to joints and then work from the lower to the upper side of the layer, overlapping on successive passes by at least one-third of the width of the rear roll or, in the case of a pneumatic-tyred roller, at least the nominal width of 300 mm.

In portions with super-elevated and uni-directional camber, after the edge has been rolled, the roller shall progress from the lower to the upper edge.

Rollers should move at a speed of not more than 5 km per hour. The roller shall not be permitted to stand on pavement which has not been fully compacted, and necessary precautions shall be taken to prevent dropping of oil, grease, petrol or other foreign matter on the pavement either when the rollers are operating or standing. The wheels of rollers shall be kept moist with water and the spray system provided with the machined shall be in good working order, to prevent the mixture from adhering to the wheels. Only sufficient moisture to prevent adhesion between the wheels of rollers and the mixture should be used. Surplus water shall not be allowed to stand on the partially compacted pavement.

After initial dry rolling, the surface shall be checked with a crown template and a 3 metre straight-edge. The surface shall not vary more than 10mm from the template or straight-edge. All surface irregularity exceeding the above limit shall be corrected by removing or adding aggregates as required.

The rolling shall continue until the compacted coarse aggregate has a firm surface true to the cross section shown on the plans and has a texture that will allow free and uniform penetration of the bitumen material.

**16.32.2.6 Application of Bituminous Material :** After the coarse aggregate has been rolled and checked, the bituminous binder shall be applied at the rate given in Table 16.21, at a temperature directed by Engineer-in-Charge.

At the time of applying the binder, the aggregates shall be surface dry for the full depth of the layer.

In certain circumstances, depending on the type and size of aggregate used, the Engineer-in-Charge may direct the placing of a bed of clean sand or quarry fines, not exceeding 10 mm in thickness, on the prepared foundation before placing the coarse aggregate. The sand or fine material shall be slightly wetted, just sufficient for it to slurry up during the compaction process. Where cut back is used, if flooding of the binder occurs it should be applied in two operations, or as directed by the Engineer-in-charge.

**16.32.2.7 Application of Key Aggregates :** Immediately after the first application of bitumen, the key aggregates, which shall be clean, dry and free from dust shall be spread uniformly over the surface by means of an approved mechanical spreader or by approved manual methods at the rate specified in Table 16.21.

Where directed by the Engineer-in-charge, the surface shall be swept and the quantity of key aggregate adjusted to ensure uniform application, with all the surface voids in the coarse aggregate being filled without excess. The entire surface shall then be rolled with a 8- 10 tonnes smooth steel wheel roller (or vibrating roller operating in non-vibratory mode) in accordance with the procedure specified in above para 16.32.2.5.

### **16.32.3 Surface Finish and Quality Control**

The surface finish of the completed construction shall conform to the requirements of section 900 of MORTH specifications. For control of the quality of materials supplied and the works carried out the relevant provisions of Section 900 of MORTH specifications.

### **16.32.4 Surfacing**

The penetration Macadam shall be provided with a surfacing (binder/wearing course) within a maximum of forty-eight hours. If there is to be any delay, the penetration macadam shall be covered by a seal coat as specified and directed by Engineer-in-charge. The seal coat in such cases shall be considered incidental to the work and shall not be paid for separately.

### **16.32.5 Arrangements for Traffic**

During the period of construction, arrangements for traffic shall be made in accordance with the provisions of specification and as per direction of Engineer-in-Charge.

### **16.32.6 Measurement for Payment**

Penetration Macadam base course shall be measured as finished work in square metres.

### **16.32.7 Rate**

The rate includes the cost of all materials, labours and equipment involved in all the operations described above.

## **16.33 BITUMEN MASTIC WEARING COURSES**

### **16.33.1 Definition**

The bitumen mastic is an intimate homogeneous mixture of mineral fillers and well graded fine and coarse aggregates with a hard grade bitumen, cooked and laid hot, troweled and floated by means of a wooden float. The mixture settles to a coherent, void less and impermeable solid mass under normal temperature conditions.

The bitumen mastic is normally used as a wearing course. Over the mastic laid surface, hard stone chips pre-coated with bitumen are grafted or spread and rolled to provide a skid resistant surface.

Bitumen mastic is used as a wearing course in different situation of heavy duty road pavements. However, use of this material is not recommended in places where abundant fuel oil dripping is expected on the pavement surfaces like bus depots, fuel filling and service stations etc.

### **16.33.2 Materials**

**16.33.2.1** The bitumen shall be industrial bitumen conforming to IS 702 of grade 85 /25 or suitable consistency satisfying the requirements of physical properties as given in Table 16.22.

**TABLE 16.22**  
**Physical Properties of Bitumen**

| S.No. | Characteristics  | Requirements | Method of Test |
|-------|--|--------------|----------------|
| 1.    | Penetration at 25 deg. C in 1/10 mm                        | 15 ± 5       | IS 1203        |
| 2.    | Softening point (R&B)                                      | 65 ± 10      | IS 1205        |
| 3.    | Ductility at 27 deg.C (Minimum in cms.)                    | 3            | IS 1208        |
| 4.    | Loss on heating, per cent (Maximum)                        | 2            | IS 1212        |
| 5.    | Solubility in trichloroethylene per cent by mass (minimum) | 95           | IS 1216        |
| 6.    | Ash (mineral matter) %age by mass                          | 1.0          | IS 1217        |

**16.33.2.2 Coarse Aggregates :** The coarse aggregates shall consist of clean, hard, durable, crushed rock free of disintegrated pieces, organic and other deleterious matter and adherent coatings. They shall be hydrophobic, of low porosity, and satisfy the physical requirements set forth in Table 16.23.

**TABLE 16.23**  
**Physical Requirements of Coarse Aggregates for Bitumen Mastic**

| S.No | Test                                       | Test Method    | Acceptance Criteria |
|------|--|----------------|---------------------|
| 1.   | (a) Los Angeles Abrasion Value<br>or       | IS 2386 (Pt.4) | 40% (Max.)          |
|      | (b) Aggregate impact value                 | -do-           | 30% (Max.)          |
| 2.   | Flakiness Index                            | IS 2386 (Pt.1) | 30% (Max)           |
| 3.   | Stripping Value                            | IS 6241        | 25% (Max)           |
| 4.   | Soundness                                  |                |                     |
|      | (i) Loss with Sodium Sulphate 5 cycles     | IS 2386 (Pt.5) | 12% (Max)           |
|      | (ii) Loss with Magnesium Sulphate 5 cycles | -do-           | 18%(Max)            |
| 5.   | Water Absorption                           | IS 2386 (Pt.3) | 2% (Max)            |
| 6.   | Retained tensile strength                  | -              | 80% (Min)           |

The percentage and grading of the coarse aggregates to be used in the bitumen mastic depending upon the thickness of the finished course shall be as in Table 16.24. The minimum and maximum thickness of the bitumen mastic for wearing course shall be 25 mm and 50 mm respectively except for footpaths of bridges where it shall be 20 mm and 25 mm respectively.

**TABLE 16.24**  
**Grading and Percentage of Coarse Aggregates for Bitumen Mastic in Wearing Course and Footpath**

| S. No | Type of work                                      | Grading of coarse aggregate |                       | Thickness of finished mastic surface course | Percentage of coarse aggregates(mm) |
|-------|---|-----------------------------|-----------------------|---|-------------------------------------|
|       |   | IS Sieve                    | %age passing IS sieve |   |                                     |
| 1.    | Wearing course for road pavement and bridge decks | 19 mm                       | 100                   | (a) 25-40<br>or                             | (a) 30-40<br>or                     |
|       |   | 13.2 mm                     | 88-96                 |   |                                     |
|       |   | 2.36 mm                     | 0-5                   | (b) 41-50                                   | (b) 40-50                           |
| 2.    | Footpaths   | 6.7 mm                      | 100                   | 20-25                                       | 15-30                               |
|       |   | 600 micron                  | 0.15                  |   |                                     |

**16.33.2.3 Fine Aggregates :** The fine aggregates shall consist of crushed hard rock or natural sand or a mixture of both. The grading of fine aggregates inclusive of filler material passing 75 micron shall be as given in Table 16.25.

**TABLE 16.25**  
**Grading of Fine Aggregate I/C Filler**

| <i>Passing IS Sieve</i> | <i>Retained on IS Sieve</i> | <i>% age by Weight</i> |
|-------------------------|-----------------------------|------------------------|
| 2.36 mm                 | 600 micron                  | 0-25                   |
| 600 micron              | 212 micron                  | 10-30                  |
| 212 micron              | 75 micron                   | 10-20                  |
| 75 micron               | —                           | 30-50                  |

**16.33.2.4 Filler :** The filler shall be limestone powder passing 75 micron and shall have a calcium carbonate content of not less than 80 per cent when determined in accordance with IS 1514.

### **16.33.3 Equipment for Bitumen Mastic**

**16.33.3.1** There are two ways of preparing a mastic. The conventional method is by using a mastic cooker which is dealt with in this specification. The other method using fully mechanized units needed for large scale work, as is generally practiced in Germany (Gussasphalt), may form the subject of a separate document.

**16.33.3.2** Mastic cooker are very similar to tar boilers. These are insulated tanks mounted on wheeled chassis. The heating of the bitumen and material is generally done by oil fired burners. Mastic cookers have compartments. The central and main compartment is used for heating bitumen and for preparing the mix. The side pockets or compartments are meant for pre-heating of the coarse and fine aggregates. Since heating is by oil fired burners, the temperature can be easily controlled by controlling the flames or supply of the fuel.

**16.33.3.3** Mastic cookers of various capacities ranging from 1/2 tonne to 3 tonne are used depending on the amount of work involved. These are not being marketed commercially because it is not a common specification but can be easily got made from manufactures of tar boilers.

Fig. 16.13 indicates the broad details of equipment and components of cooker presently in common use.

**16.33.3.4** Apart from mastic cooker, the following equipments are required for transportation and laying.

- (1) Wheel barrows and flat mortar pans (for short distance haul) and small dumpers (for long distance haul).
- (2) Wooden trowels, heavy wooden floats, suitable hand tools gauge, straight edge and hand level.
- (3) Angle irons, required to contain the mastic in desired width and thickness.

### **16.33.4 Manufacture of Bitumen Mastic**

**16.33.4.1** The manufacture of bitumen mastic involves different stages. Initially the filler alone shall be heated to a temperature of 175 deg. C to 210 deg. C in mechanically agitated mastic cooker and half the required quantity of bitumen heated at 175 deg. C to 180 deg. C added. They shall be mixed and cooked for one hour. After that the fine aggregates and the balance bitumen at 175 deg. C to 180 deg. C shall be added to that mixture in the cooker and heated upto 175 deg. C to 200 deg. C and further mixed for another one hour. In the final stage, the coarse aggregates shall be added and heating of mix shall continue for another one hour. Thus a total period of minimum three hours will be needed to prepare the mastic. During mixing and cooking, care shall be taken to ensure that the contents in the cooker are at no time heated to a temperature exceeding 210 deg. C.

**16.33.4.2** In case the material is not required for immediate use, the bitumen mastic with filler, fine aggregates and bitumen shall be cast into blocks each weighing about 25 kg. The bitumen mastic blocks (without coarse aggregates) shall show on analysis a composition with the limits as given in Table 16.26. These blocks when intended to be used subsequently shall be transported to site, broken into pieces of size not exceeding 60 mm cube and remelted in the cooker at a temperature ranging from 175 deg. C. to 210 deg. C thoroughly incorporating the requisite quantity of coarse aggregates as indicated in Table 16.26 and mixed continuously for at least an hour. Mixing shall be continued until the laying operations are completed so as to maintain the coarse aggregates in suspension. At any stage the temperature during the process of mixing shall not exceed 210 deg. C.

**TABLE 16.26**  
**Composition of Bitumen Mastic Blocks without Coarse Aggregates**

| IS Sieve        |            | % age by weight |         |
|-----------------|------------|-----------------|---------|
| Passing         | Retained   | Minimum         | Maximum |
| 2.36 mm         | 600 micron | 0               | 22      |
| 600 micron      | 212 micron | 4               | 30      |
| 212 micron      | 75 micron  | 8               | 18      |
| 75 micron       | -          | 25              | 45      |
| Bitumen content |            | 14              | 17      |

### 16.33.5 Hardness Number

The hardness number of bitumen mastic shall be determined at 25 deg. C in accordance with IS 5317 and with the method specified in Appendix D of IS 1195. It shall conform to the following requirements:

- (1) Without coarse aggregates at 25 deg. C                      60-80
- (2) With coarse aggregates at 25 deg. C                         10-20

### 16.33.6 Laying the Bitumen Mastic

**16.33.6.1 Preparation of the Base :** The base on which bitumen mastic is to be laid shall be prepared, shaped and conditioned to the specified levels, grade and camber as directed. If the existing surface is too irregular and wavy, it shall be made good by providing a corrective course of bituminous concrete mix as per IRC:29. The surface shall be thoroughly swept clean and made free of dust and other deleterious matter. Spots rich in binder shall be scrapped and repaired. Under no circumstances the bitumen mastic sheet be spread on a base containing a binder which will soften under high application of temperature. If any such spot exists, the same shall be cut out and repaired before the bitumen mastic is laid. To receive and contain the mastic, angle irons of sizes 25 or 50 mm are placed at required spacing till finish of the job.

**16.33.6.2 Transportation of Mix :** When the bitumen mastic, duly prepared including addition of coarse aggregates at the manufacturing point, is to be transported over a long distance and delivered to the laying site, arrangements for transport shall be made in a towed mixer transporter with adequate provision for heating and stirring so as to keep the aggregates and filler suspended in the mix till the time of laying. However for small works and where the laying site is near the manufacturing point, the mix can be transported in wheel barrows/flat mortar pans. To prevent the molten material from sticking to the wheel barrows/pans, the inside of the transport may be sprinkled with a minimum quantity of inorganic fine material like limestone dust. However, cement, ash or oil shall not be used.

### 16.33.6.3 Laying of Mix

**16.33.6.3.1** The bitumen mastic shall be discharged into containers sprinkled with limestone dust or provided with lime-wash. The bitumen mastic shall be deposited directly on the prepared base immediately in front of the spreader where it is spread uniformly by means of wooden floats to the required thickness. The mix shall be laid in one metre widths confined between standard angle irons of size 25 mm to 50 mm to receive and contain the mastic of required thickness. The temperature of the mix at the time of laying shall be 175 deg. C. In case blowing takes place while laying the bitumen mastic, the bubbles shall be punctured while the mastic is hot and the surface made good. Since mastic asphalt is an expansive material, extreme care shall be taken while fixing the angle irons and their level checked with instrument at suitable intervals.

**16.33.6.3.2 Laying Bitumen Mastic Surfacing over Old Existing Bridge Deck :** Before laying bitumen mastic over old existing bridge deck, the existing cross fall/camber, expansion joint members and water drainage spouts shall be carefully examined for their proper functioning in the bridge deck structure and any deficiency found shall first be removed. Loose elements in the expansion joint shall be firmly secured. The cracks in the concrete surface, if any, shall be repaired and filled up properly or replaced by new concrete of specified grade before laying the bitumen mastic over bridge deck.

**16.33.6.3.3 Laying over New Bridge Deck :** New concrete bridge deck which is not in camber/cross fall shall first be provided with required camber and cross fall by suitable concrete or bituminous treatment. In case of laying over concrete surface, following measures shall be taken:

- (1) For proper bond with new concrete deck, surface shall be roughened by means of stiff broom or wire brush and it shall be free from ridges and troughs.
- (2) A thin bituminous tack coat (with bitumen of grade 80/100) shall be applied on the concrete deck before pouring mastic. The quantity of bitumen for tack coat shall not exceed 5-6 kg per 10 sqm.
- (3) On surface in longitudinal slope, after applying tack coat, chicken-mesh reinforcement of 1.5 mm dia steel wire with hexagonal or rectangular openings of 20-25 mm shall be placed and held properly in position on the concrete surface before pouring mastic.

### 16.33.7 Joints

All construction joints shall be properly and truly made. These joints shall be made by warming the existing bitumen mastic by the application of an excess quantity of hot bitumen mastic which afterwards shall be trimmed off to make it flush with surface on the either side.

### 16.33.8 Surface Finish

The bitumen mastic surfacing has got a very fine texture which on initial laying provides very little resistance to skidding. Therefore, the bitumen mastic after spreading and while still hot and in plastic condition shall be spread over with bitumen precoated fine grained hard stone chips/aggregates of approved quality of 13.2 mm size complying with quality requirement as per Table 16.27 depending upon the thickness of mastic, using bitumen at the rate of 2 to 3 percent of S-65 or S-90 grades and aggregates at the rate of 0.005 cum (1/200 cum) per 10 sqm. and at a spacing of 10 cm c/c in both directions and pressed into the surface when the temperature of bitumen mastic is between 80 deg. C. and 100 deg. C. Such precoated aggregates when laid should protrude 2 to 4 mm over the mastic surface. Flakiness index of stone aggregates used for anti-skid measures shall be less than 25 per cent. The addition of 2% filler complying with Table 16.28/16.30 may be required to enable the quantity of bitumen to be held without draining.

**TABLE 16.27**

| <i>Sl.No.</i> | <i>Name of Test</i>  | <i>I.S.Code</i>     | <i>Acceptance Criteria</i>         |
|---------------|--|---------------------|------------------------------------|
| 1.            | Grain size analysis  | IS 2386 Part 1      | Max. 5% passing IS sieve 75 micron |
| 2.            | Flakiness or elongation Index                              | IS 2386 Part 4      | Max. 30% *                         |
| 3.            | Los Angeles Abrasion Value                                 | -do-                | Max. 30%                           |
| 4.            | Polished Stone Value                                       | B.S. 812 (Part 114) | Min. 55                            |
| 5.            | Soundness<br>(a) Sodium Sulphate<br>(b) Magnesium Sulphate | IS 2386 (Part 5)    | Max. 12%<br>Max. 18%               |
| 6.            | Water absorption   | IS 2386 Part 3      | Max. 2%                            |
| 7.            | Coating and stripping of bitumen aggregate mixture         | IS 6241             | Min retained coating 95%           |
| 8.            | Water sensitivity retained tensile strength                | AASHTO T 283        | Min. 80% **                        |

\* The elongation test to be done only on non-flaky aggregate to the sample.

\*\* This test is only required if the maximum retained coating in the stripping test is less than 95%.

**TABLE 16.28**

| <i>Sl. No.</i> | <i>IS Sieve (MM)</i> | <i>Cummulative percent passing by weight of total aggregate</i> |
|----------------|----------------------|---|
| 1.             | 0.6                  | 100   |
| 2.             | 0.3                  | 95-100  |
| 3.             | 0.075                | 85-100  |

The traffic may be allowed after completion of work when the bitumen mastic has cooled down to the ambient temperature.



### **16.33.9 Controls**

**16.33.9.1** Sieve analysis of each type of the aggregate used shall be made at least once a day to see that the gradation of the aggregates follows the original gradation as approved. Additional tests shall be carried out in case of variation in grading or receipt of supply of material from new source. The number of samples to be tested per day would depend upon the bulk supply of aggregates made in a day at the plant site. Physical properties such as aggregate impact values, flakiness index, water absorption etc. shall be determined at the rate of one test for every 25-50 cum of aggregates or as directed by the Engineer at site.

**16.33.9.2** Two sets of test shall be carried out on each lot of supply of bitumen for checking penetration and softening point as per IS 1203 and IS 1205.

**16.33.9.3** For filler material calcium carbonate content and fineness shall be tested at the rate of one set of tests for each consignment subject to a minimum of one set of test per 5 tonne or part thereof.

**16.33.9.4** It shall be ensured that the aggregates are not wet before heating, otherwise it would affect the output adversely. During heating the aggregate temperature shall be recorded periodically to see that it does not exceed the limits prescribed.

**16.33.9.5** Material in block form shall be sampled by taking approximately equal amount in pieces, from not less than six blocks chosen at random. The total weight of specimen to be tested shall not be less than 5 kg. In case the preparation of the mix is at site, then at least one sample of every 10 tonne of bitumen mastic discharged from the mastic cooker or at least one sample for each cooker per day shall be collected and following tests done:

- (1) Two specimens each of 10 cm dia or 10 cm square and 2.5 cm thick shall be prepared and tested for hardness number.
- (2) Bitumen shall be extracted from about 1000 gm of the mastic sample and bitumen content determined as specified in Appendix C of IS 1195.
- (3) A sieve analysis of the aggregates after the bitumen is extracted, shall be done and the gradation determined according to the procedure laid down in IS 2386 (Pt.I).

**16.33.9.6** The temperature of the bitumen mastic at the time of laying shall not exceed 210 deg. C and shall not be less than 175 deg. C.

**16.33.9.7** The longitudinal profile of the finished surface shall be tested with a straight edge 3 m long and transverse profile with a camber template while the mastic laid is still hot. Irregularities greater than 4 mm in the longitudinal and transverse profile shall be corrected by picking up the mastic in full depth and full area of the affected panel and relaying.

**16.33.9.8** Bitumen mastic shall not be laid on a damp or wet surface or when the atmospheric temperature in the shade is 15 deg. C or less.

### **16.33.10 Measurements**

The length & breadth of the area where bitumen mastic wearing course of specified thickness has been provided shall be measured correct to a centimeter and the area shall be calculated in square metres correct to two decimal places.

### **16.33.11 Rate**

The rate per square metre shall include cost of all the operations described above including anti-skid treatment mentioned in para 16.33.1 above.

### 16.34 BITUMINOUS SHEET WITH HOT BITUMEN

**16.34.0** This type of treatment is normally done for garden paths, driveways, footpaths and playgrounds and roads. The treatment is also useful in providing a thin wearing course over existing cement concrete roads. This is sometimes capable of standing with very heavy traffic. This can also be used over worn out cement concrete pavements, the concrete surface is roughened before laying the binder coat. It is also useful as a corrosion resistant flooring in shade and godowns for storing salt, fertilizer etc. This treatment consists of a mixture of coarse sand and stone chippings with bituminous binder, spread and consolidated to a specified thickness on prepared surface after the application of a tack coat.

The consolidated thickness of this type of treatment shall be 2.5 cm or 4 cm, as specified.

The work shall be carried out only when the atmospheric temperature in shade is 16 deg. C or above. No bituminous material shall normally be applied when the road surface or material is damp or when the weather is foggy or rainy, or during dust storms. Bitumen of specified grade and consistency to be used.

#### 16.34.1 Quantities of Materials

The quantities of materials shall be as specified in Table 16.29.

**TABLE 16.29**

| Consolidated thickness of bituminous sheet | Bitumen VG- 10/ VG-30/ Refinery modified bitumen (RMB 55) |                          |                | Stone chippings cum/100 sqm of road surface | Coarse sand cum/100 sqm of road surface |
|--|---|--------------------------|----------------|---|---|
|  | Kg/sqm of surface area (For Tack Coat)                    | Kg/cum of stone chipping | Kg/cum of sand |   |   |
| 2.5 cm                                     | 0.75  | 56                       | 128            | 1.65*                                       | 1.65                                    |
| 4 cm                                       | 0.75  | 56                       | 128            | 2.60*                                       | 2.60                                    |

\* 60% with 12.5 mm Nominal size and

\* 40% with 10 mm Nominal size

A proper record shall be kept to ensure that the daily turn out of work is correlated with the quantity of bitumen used as per proforma prescribed in Appendix 'A' .

**16.34.2** Preparation of surface and application of binder (tack coat ) shall be as specified under 16.28.2 to 16.30.5.

#### 16.34.3 Preparation of Mix, laying and Consolidation

Para 16.30.4 and 16.30.5 shall generally apply except that the mixing shall be done in two stages. Stone aggregate of the correct standard size and in the proportion shown in table 16.29 shall be fed into the mixer to which 2/3 rd of the total specified quantity of bitumen heated to the appropriate temperature shall be added. When the stone metal is well coated, the sand in the specified proportion and then the balance 1/3rd quantity of total bitumen shall be fed into the mixer. Mixing shall be continued until a homogeneous mix is produced and all particles are uniformly coated with bitumen.

Any high spots or depressions which become apparent shall be corrected by addition or removal of premixed materials. The rolling shall continue until the maximum consolidation to the satisfaction of Engineer-in -Charge is obtained. The wheels of the roller shall be moistened with gunny bags to prevent the mixture from sticking to the wheel while rolling.



**16.34.4** Surface finishing and rectification shall be as specified under 16.30.6 and 16.30.7.

**16.34.5 Permitting Traffic**

Traffic shall be allowed on the road after a lapse of 24 hours to 48 hours after laying, as decided by the Engineer-in-Charge.

**16.34.6 Measurements**

The length and width of the finished work shall be measured correct to a cm along the finished surface of the road. The area shall be calculated in square metre, correct to two places of decimal.

For record purposes measurements for binder, stone aggregate, stone chippings and sand as described under 16.3 shall be taken before they are actually used on the work. Premeasurements shall simply serve as a guide and shall not form the basis for payment. The thickness of surface treatment shall be the ruling criterion for payment.

**16.34.7 Rate**

The rate shall include the cost of materials and labour involved in all the operations described above.

**16.35 SEAL COAT**

**16.35.1 Scope**

This work shall consist of the application of a seal coat for sealing the voids in a bituminous surface laid to the specified levels, grade and cross fall (camber).

**16.35.2** Seal coat shall be of either of the two types specified below:

- (A) Liquid seal coat comprising of an application of all layer of bituminous binder followed by a cover of stone chips.
- (B) Premixed seal coat comprising of a thin application of the aggregate premixed with bituminous binder.

**16.35.3 Materials**

**16.35.3.1 Binder :** The binder and its quantity shall be a penetration bitumen of a suitable grade as specified in the item or as directed by the Engineer-in-charge.

**16.35.3.2 Stone Chips for Seal Coat :** The stone chips shall consist of angular fragments of clean, hard, tough and durable rock of uniform quality throughout. They should be free of soft or disintegrated stone, organic or other deleterious matter. Stone chips shall be of 6.7 mm size defined as 100 per cent passing through 11.2 mm sieve and retained on 2.36 mm sieve. The quantity used for spreading shall be 0.09 cubic metre per 100 square metre area. The stone chips shall satisfy the quality requirements in Table 16.31 bituminous except that the upper limit for water absorption value shall be 1 per cent.

**TABLE 16.30**

| <i>Sl. No.</i> | <i>I.S. Sieve (mm)</i> | <i>Cumulative % passing by weight of total aggregate</i> |
|----------------|------------------------|--|
| 1.             | 0.6                    | 100  |
| 2.             | 0.3                    | 95-100   |
| 3.             | 0.075                  | 85-100   |

**TABLE 16.30**

| <i>Sl. No.</i> | <i>Name of Test</i>  | <i>I.S. Code</i>    | <i>Acceptance Criteria</i>        |
|----------------|--|---------------------|-----------------------------------|
| 1.             | Grain size analysis  | IS 2386 Part 1      | Max 5% passing IS sieve 75 micron |
| 2.             | Flakiness and elongation Index                             | IS 2386 (Part 4)    | Max 30%                           |
| 3.             | Los Angeles Abration Value                                 | IS 2386 (Part 4)    | Max 30%                           |
| 4.             | Polished stone value                                       | B.S. 812 (part 114) | Min 55%                           |
| 5.             | Soundness<br>(a) Sodium sulphate<br>(b) Magnesium sulphate | IS 2386 (Part 5)    | Max 12%<br>Max 18%                |
| 6.             | Water absorption   | IS 2386 (Part 3)    | Max 2%                            |
| 7.             | Coating and stripping of Bitumen aggregate mixture         | IS 6241             | Min retained coating 95%          |
| 8.             | Water sensitivity retained tensile strength                | AASHTOT 283         | Min 80%                           |

\* The elongation test to be done only on non-flaky aggregate on the sample.

\*\* This test is only required if the minimum retained coating in the stripping test is less than 95%.

**16.35.3.3 Fine Aggregate :** The aggregate shall be sand or grit and shall consist of clean, hard durable, uncoated dry particles and shall be free from dust, soft or flaky/elongated material, organic matter or other deleterious substances. The aggregate shall pass 2.36 mm sieve and be retained on 180 micron sieve. The quantity used for premixing shall be 0.06 cubic metres per 100 square metres area. Stones or fine aggregate shall be used as specified in item.

#### **16.35.4 Construction Operations**

**16.35.4.1 Weather and Seasonal Limitations :** Ref. Item No. 16.32.2.1.

**16.35.4.2 Preparation of Surface :** The seal coat shall be applied immediately after laying the bituminous course which is required to be sealed. Before application of seal coat materials, the surface shall be cleaned free of any dust or other extraneous matter.

**16.35.4.3 Construction of Seal Coat with Stone Chips :** Bitumen shall be heated to 150°C - 163°C and sprayed at the rate specified on the dry surface in a uniform manner with a self-propelled mechanical sprayer

Immediately after the application of binder, stone chips which shall be clean and dry, shall be spread uniformly at the rate specified on the surface preferably by means of a self-propelled or towed mechanical grit spreader so as to cover the surface completely. If necessary, the surface shall be brushed to ensure uniform spread of chips.

Immediately after the application of the cover material, the entire surface shall be rolled with a 8-10 tonne smooth wheeled steel roller, 8-10 tonne static weight vibratory roller, or other equipment approved by the Engineer after laying trials if required. Rolling shall commence at the edges and progress towards the centre except in super elevated and unidirectional cambered portions where it shall proceed from the lower edge to the higher edge. Each pass of the roller shall uniformly overlap not less than one-third of the track made in the proceeding pass. While rolling is in progress, additional chips shall be spread by hand in necessary quantities required to make up irregularities. Rolling shall continue until all aggregate particles are firmly embedded in the binder and present a uniform closed surface.

**16.35.4.4 Construction of Seal Coat with Premixed Fine Aggregate :** A mixer of appropriate capacity and type approved by the Engineer-in-charge shall be used for preparation of the mixed material. The plan shall have separate dryer arrangements for heating aggregate.

The binder shall be heated in boilers of suitable design, approved by the Engineer-in-Charge to the temperature appropriate to the grade of bitumen or as directed by the Engineer-in -Charge. The aggregates shall be dry and suitably heated to a temperature between 150°C and 165°C or as directed by the Engineer-in-charge before these components are placed in the mixer. Mixing of binder with aggregates to the specified proportions shall be continued until the latter are thoroughly coated with the former.

The mix shall be immediately transported from the mixing plant to the point of use and spread uniformly on the bituminous surface to be sealed.

As soon as a sufficient length has been covered with the premixed material, the surface shall be rolled with an 8-10 tonne smooth-wheeled roller. Rolling shall be continued until the premixed material completely seals the voids in the bituminous course and a smooth uniform surface is obtained.

#### **16.35.5 Opening to Traffic**

In the case of seal coat with premixed fine aggregate traffic may be allowed soon after final rolling when the premixed material has cooled down to the surrounding temperature. In the case of seal coat with stone chips traffic shall not be permitted to run on any newly sealed area until the following day. In special circumstances, however, the Engineer-in-charge may open the road to traffic immediately after rolling, but in such case traffic speed shall be rigorously limited to 16 km. per hour until the following day

#### **16.35.6 Measurement for Payment**

Seal coat, for both items shall be measured as finished work over the area specified to be covered, in square metres at the thickness specified in the item.

#### **16.35.7 Rate**

The rate for seal coat shall be cost of all materials, labour and equipment involved in operation described above.

### **16.36 CEMENT CONCRETE PAVEMENT (UNDER ORDINARY CONDITIONS)**

Specifications of item 16.37 to be followed except that cement concrete of grade 1:2:4 or specified otherwise to be prepared and compacted.

### **16.37 CEMENT CONCRETE PAVEMENT UNDER CONTROLLED CONDITIONS**

#### **16.37.1 Materials**

##### **16.37.1.1 Cement**

- (a) Cement used on work shall be as per sub head cement concrete of CPWD specifications-2019 (Vol. – I).

**16.37.1.2 Water :** Water used on work shall conform to SH: cement concrete of CPWD, Specification 2019- Vol. I.

**16.37.1.3 Coarse Aggregate :** These shall be crushed or broken from hard stones obtained from approved quarry. These shall be clean strong, durable of fairly cubical shape and free from soft, friable, thin elongated and laminated disintegrated pieces. These shall also be free from dirt, organic deleterious and any other foreign matter and adherent coatings and shall satisfy the physical requirements laid down in para 16.37.19 under quality control.

**16.37.1.4 Fine Aggregate :** This shall be coarse sand conforming to CPWD Specification 2019 Vol. I.

**16.37.1.5 Grading of Mixed Aggregates :** The grading of all aggregates (coarse and fine aggregates) to be used in the work shall be determined in the laboratory. The coarse and fine aggregates shall be mixed in suitable proportions so that the grading of the mixed aggregates shall be in the range indicated in Table 16.32.

**TABLE 16.32**

| <i>I.S. Sieve Size (IS 460)</i> | <i>% age passing by weight</i> |
|---------------------------------|--------------------------------|
| 45 mm                           | 100                            |
| 22.4 mm                         | 55 - 60                        |
| 11.2 mm                         | 45 - 50                        |
| 5.6 mm                          | 35 - 40                        |
| 2.8 mm                          | 30 - 35                        |
| 1.4 mm                          | 20 - 25                        |
| 710 microns                     | 15 - 20                        |
| 355 microns                     | 10 - 14                        |
| 180 microns                     | 2 - 5                          |

**16.37.2 Mix Design**

**16.37.2.1** The mix shall be approved by Engineer-in- Charge so as to obtain the following mean strength that exceeds the minimum specified flexural strength by 1.64 times the designed standard deviation.

|   |   |   |
|---|---|---|
| Minimum works beam flexural strength at 28 days | = | 300 kg/sqm. for M-30 or specified in item     |
| Designed standard deviation                     | = | 60 kg/sqm. for M-30 or for specified grade(s) |
| Design flexural strength at 28 days             | = | 300+60x1.64                                   |
| Water cement ratio by weight                    | = | 398.4 kg/sqm. (f + 1.64 s )<br>says 400 kg.   |
| Water cement ratio by weight                    | = | 0.5   |
| Minimum slump not more than 25 mm               |   |   |

**16.37.2.2** For the purpose of tendering the contractor shall base his rate on the assumption that the quantity of cement used for one cum. of finished concrete shall be 340 kg. or M - 30. If the actual quantity of cement required to be used as a result of the laboratory test is different from that assumed above, necessary adjustment in the cost due to short cement used shall be made on the basis of issue rate of cement including storage charges plus 2.5% for handling charges. However, under no circumstances the quantity of cement to be used shall either exceed 350 kg./cum or fall below 330 kg. per cum of finished concrete.

**16.37.3 Statistical Field Check**

**16.37.3.1** Samples of concrete shall be taken at the mixer and works beams, made, cured and tested in accordance with IS 1199 and IS 516.

**16.37.3.2** When a mix is used for the first time, it is important to get a large number of results, as soon as possible, in order to establish the level of control and then suitability of the mix proportions. A sample of concrete shall be taken at random on eight separate occasions during each of the first five days of using that mix. From each sample two beams shall be made one for test at 7 days and the other for test at 28 days.

**16.37.3.3** The work beam results shall be examined both individually and in consecutive (but not overlapping) sets of four, for which the average and the range of each set is calculated. The mix proportions shall be modified to increase the strength, if in the first ten consecutive (but not overlapping) sets any of the following conditions are not satisfied.

(I) Each sample has a test strength not less than the minimum specified strength i.e. 30 kg/sq. cm. (or otherwise specified in item).

OR

(II) (a) Not more than two individual results (Not more than one of first twenty) of the 40 beams tests shall fall below the minimum work beam strength but they shall not be less than 80% of the specified beam strength of 30 kg./sq. cm (or otherwise specified in item) or the minimum specified strength minus 1.35 times the standard deviation whichever is greater.

(b) No value of the range in any set shall exceed 3 times the designed standard deviation.

(c) The average for all samples (10 sets) shall not be less than the minimum specified strength i.e. 30 kg/sq. cm (or otherwise specified in item) plus 1.64 times the designed standard deviation 60 kg./sq.cm M-30.

**16.37.3.4** If either of these conditions (16.37.3.3 I or 16.37.3.3 II) are not satisfied, the mix shall be modified and the procedure described above shall be repeated till results satisfying the above criterias are obtained.

**16.37.3.5** Subsequently samples shall be taken at the rate of one for every 30 cubic metre of concrete laid. Eight beam specimen shall constitute one sample. A set of 4 specimen shall be tested after 7 days and another set of 4 specimen shall be tested after 28 days. These test results shall be checked individually and in sets of four as the work progresses. If at any stage it is found that either of conditions 16.43.4.3,I or 16.4.3,II are not satisfied, the overall average and the standard deviation of the previous consecutive 40 beam test results including the non-complying set shall be calculated. If the overall average strength minus 1.64 times the standard deviation is more than the specified beam strength (30 kgm/sq.cm) (or otherwise specified in item) the concrete shall be accepted. But if it is less than the concrete work corresponding to these 40 beams tests shall be rejected and the mix proportion shall be modified forth with for further work. The rejected work shall be replaced by the contractor immediately at his own cost and expense.

**16.37.3.6** The statistical field checks described in 16.37.3.1 to 16.37.3.2 are meant to control the quality of concrete. The standard of acceptance of concrete shall be governed by the provision of para 16.37.3.3 to 16.37.3.5.

#### **16.37.4 Slump Test**

The test shall be carried out as per IS 1199. A slump test shall be carried out at each mixer at least one in fifty batches mixed or more frequently if directed by the Engineer- in-Charge. Any batch from which slump test is being made shall not be transferred to the place of laying till the slump test has been completed. Not only the batch which gives a slumps in excess of that specified shall be rejected but the concrete already laid immediately preceding the batch tested upto the nearest last transverse joint may be rejected by the Engineer-in-Charge or his subordinate, if he is satisfied that such preceding batches were substandard in this respect. The decision of the Engineer-in-Charge in this respect shall be final and binding on the contractor. Such rejected concrete shall be removed by the contractor immediately and replaced with proper slump concrete at his cost and expense.

#### **16.37.5 Steel Forms**

**16.37.5.1** All side forms shall be of mild steel. The steel forms shall be of M.S. Channel sections and their depth shall be equal to the thickness of the pavement.

**16.37.5.2** The side forms shall have a length of at least 3.0 metres except on curves of less than 4.5 metres radius where shorter lengths may be used. When set to grade and stacked in place the maximum deviation of the top surface of any section from a straight line shall not exceed 3 mm. The method of connection between sections shall be such that the joint formed shall be free from play or movement in any direction. The use of bent, twisted or worn out forms shall not be permitted. At least three stake pockets for bracing pins or stakes shall be provided for each 3.0 M length of forms. Bracing and supports must be ample to prevent the springing of forms under pressure of concrete or weight or thrust of the machinery (like screed vibrator) operating on the forms. Support to the forms shall be sufficiently rigid to hold them in position during the entire operation of laying and compacting and finishing and that they shall not at any time deviate more than 3 mm from straight edge 3 metres in length. Forms which show a variation from the required rigidity of the alignment and levels shown on the plans shall be reset or removed as directed. The length and number of pins or stakes shall be such as to maintain the forms at the correct line and grade.

**16.37.5.3** The supply of forms shall be sufficient to permit their remaining in place for at least 12 hrs. after the concrete has been placed or longer, if in the opinion of the Engineer-in-Charge, it is necessary.

**16.37.5.4** The top line of the forms is not to vary from the correct level or alignment and the levels and alignment of the forms are to be checked and corrected as necessary immediately prior to the placing of concrete. The top edges and faces of the forms are to be carefully cleaned and maintained in clean condition.

**16.37.5.5** While removing the steel forms, care shall be taken to withdraw them gradually, any damage to the bull nosed edges shall be made good while the concrete is still green.

**16.37.5.6 *Setting of Forms***

- (a) Setting of forms shall be according to the slab plan subject to the approval of Engineer-in-Charge and concreting shall not commence until the setting of forms is approved.
- (b) Forms shall be set for at least 50 metres in advance of the point where the concrete is being laid and shall not be removed until at least 12 hrs. of placing of the concrete or longer if in the opinion of Engineer-in-Charge is necessary.
- (c) After setting, the working faces shall be thoroughly oiled by using approved oil before concrete is placed against them.
- (d) The pavement joints of overlay layer would overlap with the joints of underlay cement concrete.

**16.37.6 *Batching and Mixing***

As detailed in SH: 5 of reinforced cement concrete work of CPWD specifications 2019.

**16.37.7 *Placing of Concrete***

As detailed in SH: 5 of reinforced cement concrete work of CPWD specifications 2019.

**16.37.8 *Compaction of Concrete***

**16.37.8.1** Compaction shall be carried out by electrically (or) diesel operated needle and screed vibrators as stipulated hereafter. Needle vibrator should be used all over the area for obtaining initial compaction of concrete. These should be of diameter not less than 4.5 cm. If the vibrator are pneumatic the pressure must not be below 4 kg/sq.cm. If electrically operated, they should have a minimum frequency of 3500 impulses per minute.



**16.37.8.2** There should be at least three needle vibrators working in any bay. A vibrating screed consisting of a steel or timber section weighing not less than 15 kg. per metre with a tamping edge of not less than 7 cm width and having a vibrator mounted thereon shall follow needle vibrators to obtain full compaction. The face of the wooden tamping edge of the screed shall be lined with M.S. Plate rigidly fixed by means of counter sunk screw. Where screed vibrators are used for compaction, a standby unit shall always be maintained ready for use, should the other one go out of order. Where electrically driven vibrators are employed, a standby diesel pneumatic unit shall be kept ready for use in case of power failure. At the discretion of the Engineer-in-Charge, for compaction at edges and joints, vibrators may be supplemented by hand tamping and rodding for securing satisfactory results. Under no circumstances, honey combing of concrete at joints or elsewhere shall be permitted.

**16.37.8.3** When using screed vibrator for compaction it should not be dragged over the concrete. During the initial passes it shall be lifted to the adjacent forward position in short steps, subsequently, it shall be slowly slid over the surface with its axis slightly tilted away from the direction of sliding and the operation repeated until a close, dense surface is obtained.

**16.37.8.4** Concreting shall be carried out in one operation between the expansion joints and construction joints without any break at the dummy joints.

**16.37.8.5** Concrete shall be deposited on the base as near the joints as possible without touching them. It shall then be shoveled against the sides, maintaining equal pressure and deposited approx. 50 mm higher than the depth of the joints, care being taken that it is worked well around the joints. The concrete shall not be dumped from the bucket directly upon or against the joints.

**16.37.8.6** Workmen shall not be allowed to walk on freshly laid concrete and proper cat walk shall be provided with independent supports beyond concreting bays.

### **16.37.9 Finishing of Concrete**

**16.37.9.1** During compaction, any low or high spots shall be made up by adding or removing concrete. After longitudinal floating has been completed but while concrete is still plastic, the slab surface shall be tested for trueness with a 3 m straight edge. Any depressions or high spots showing departure from the true surface shall be immediately rectified. High spots shall be cut down and refinished. Depressions shall be enlarged to about 8-10 cm and filled up with fresh concrete, compacted and finished.

**16.37.9.2** The straight edge testing the refloating is to continue until the entire surface:

- (a) is free from observable departure from the straight edge,
- (b) conforms to the required levels and across section, and
- (c) shall conform to the specified surface when the concrete has hardened.

**16.37.9.3** The foregoing work is to be carried out while the concrete is still plastic and workable.

### **16.37.10 Belting**

**16.37.10.1** Just before concrete becomes non-plastic, the surface shall be belted with a two ply canvas belt not less than 20 cm wide and at least 1 metre longer than the width of the slab. Hand belts shall have suitable handles to permit controlled uniform manipulation. The belt shall be operated with short strokes transversed to the centre line of the pavement and with rapid advance parallel to the centre line.



### **16.37.11 Brooming**

**16.37.11.1** After belting and as soon as the surplus water, if any, has risen to the surface, the pavement shall be given a broom finish with an approved steel or fiber broom not less than 45 cm wide. The broom shall be pulled gently over the surface of the pavement from edge to edge. Adjacent strokes shall be slightly overlapped. Brooming shall be perpendicular to the centre line of the pavement and so executed that the corrugations formed shall be uniform in character and width and not more than 1.5 mm deep.

**16.37.11.2** Brooming shall be completed before the concrete reaches such a stage that the surface is likely to be torn or unduly roughened by the operation. The broomed surface shall be free from porous or rough spots, irregularities, depressions, and small pockets such as may be caused by accidental disturbing of particles of coarse aggregates embodied near the surface. The brooming shall be of uniform pattern all through.

**16. 37.11.3 Edging :** After belting/brooming has been completed but before the initial setting of concrete, the edges of the slab shall be carefully finished with an edger of 6 mm radius, and the pavement edges shall be left smooth and true to line.

### **16.37.12 Honey Combing**

**16.37.12.1** The side forms shall not be removed until 12 hours or such longer period as the Engineer-in-Charge may decide after the laying of concrete.

**16.37.12.2** As soon as the side forms are removed, any minor honey combed area shall be filled with mortar composed of one part of cement and two parts of fine aggregate. Major honey combing areas or segregated concrete or other defective work or areas damaged by removal of the forms or concrete damaged by rain or due to any other reason whatsoever shall be considered as defective work and shall be removed and replaced by the contractor at his own expense. The total area of honey combed surface shall not exceed 4 per cent of the area of the slab side. However, no individual honeycomb patch shall exceed 0.1 sqm. Engineer-in-Charge's decision as to whether the concrete is defective or not shall be final and binding.

### **16.37.13 Surface Accuracy**

**16. 37.13.1** After the concrete has sufficiently hardened after about 12 hours and not later than 24 hours, the surface shall be tested again for high spots. All high spots shall be marked and those exceeding 3 mm shall be ground down immediately. Care shall be taken to see that the grinding does not in any way damage the concrete surface.

**16.37.13.2** The final surface finish is to be such that when tested with a profilograph/roughness indicator/or a 3 metre long straight edge or an equivalent mechanical unevenness indicator placed anywhere within the same or adjoining slab in any direction on the surface, there shall be no variation greater than 3 mm.

**16.37.13.3** If the surface irregularity exceeding 3 mm still remains despite grinding as per para 16.37.13.2 the concrete shall be removed to its full depth. The area of concrete to be removed shall be complete slab between the nearest joints, where the defective slab is less than 4.5 metres from the expansion joint, the whole area upto the expansion joint shall be removed to the full depth. The concrete so removed shall not be reused in the work. Fresh concrete shall be laid in the manner already de-scribed in above paras and shall again be subject to test for surface accuracy and other quality control measures. Nothing extra shall be paid on this account.

**16.37.13.4** Every slab shall bear an impression not exceeding 3 mm in depth comprising the number allotted to the slab and the date on which it is laid. This impression shall be formed by the contractor when the concrete is green so as to leave permanent mark on setting.

#### **16.37.13.5 Initial Curing**

**16.37.13.5.1** Immediately after completion of the finishing operations, the surface of the pavement shall be entirely covered with wetted burlap, cotton or jute mats. The mats used shall be of such length (or width) that as laid they shall extend at least 45 cm beyond the edges of the slab. The mats shall be placed so that the entire surface and both edges of the slab are completely covered. This covering shall be placed as soon as, in the judgment of the Engineer- in-Charge the concrete has set sufficiently to prevent damage to the surface prior to being placed, the mats shall be thoroughly saturated with water and shall be placed with the wettest side down. The mats shall be so placed and weighed down as to cause them to remain in intimate contact with the surface covered, and the covering shall be maintained full wetted and in position for 24 hours after the concrete has been placed or until the concrete is sufficiently hard to be walked on without suffering damage. Water shall be gently sprayed so as to avoid damage to the fresh concrete. If it becomes necessary to remove a mat for any reason, the concrete slab shall not be exposed for a period of more than half an hour.

**16.37.13.5.2** Worn burlap or burlap with holes shall not be permitted. Burlap reclaimed from previous use other than curing concrete shall be thoroughly washed prior to use for curing purposes. If burlap is obtained in strips, shall be laid to overlap by at least 150 mm.

**16.37.14** Burlap shall be placed from suitable bridges. Walking on freshly laid concrete to facilitate placing burlap shall not be permitted.

#### **16.37.15 Final Curing**

**16.37.15.1** Upon the removal of the burlaps, the slab shall be thoroughly wetted and then cured as follows:-

All joints shall be filled with filler in order to prevent the edges of joints from getting damaged and entry of clay materials into the joints during final curing. Exposed edges of the slab shall be banked with a substantial berm of earth. Upon the slab shall then be laid a system of transverse and longitudinal dykes of clay about 50 mm high immediately covered with a blanket of sandy soil free from stones to prevent the drying up and cracking of clay. The rest of slab shall then be covered with sufficient sandy soil so as to produce a blanket of earth not less than 40 mm deep after wetting. The earth covering shall be thoroughly wetted while it is being placed on the surface and against the sides of the slab and kept thoroughly saturated with water for 21 days and thoroughly wetted down during the morning of the 22nd day and shall thereafter remain in place until the concrete has attained the required strength and permission is given by the Engineer-in-Charge. Thereafter the covering shall be removed and the pavement cleaned and swept. If the earth covering becomes displaced during the curing period, it shall be replaced to the original depth and resaturated.

**16.37.15.2** Contractor shall appoint chowkidars at his expense to prevent workmen, cattle, etc., straying on the pavement concrete.

**16.37.15.3** Concrete shall not be subjected to any load or weight of any plant until at least 28 days after laying.

#### **16.37.16 Construction Joints**

**16.37.16.1** Construction joints shall be provided as shown in the drawing and also at places where concreting is stopped due to unforeseen circumstances. The joints shall be straight and vertical through the full thickness of the slab. While concrete in adjacent bay is still green, flats of suitable size shall be drawn along the edge and a groove of size 10 mm × 25 mm deep shall be neatly formed and finished. The edges of the groove shall be full nosed. After curing of concrete is complete, this

groove shall be thoroughly cleaned of all sand dust and shall be perfectly dried and filled with hot poured sealing compound conforming to grade B of IS 1834. Before filling with sealing compound the faces of concrete of the joint shall be coated with primer of approved brand to a depth of 25 mm at the rate of 2.6 liters per 10 square meters. Bitumen emulsion shall not be used as primer.

#### **16.37.17 Dummy Joints**

**16.37.17.1** The joints shall be 10 mm wide and shall extend vertically from the surface of the slab to a depth equal to 1/3rd of the thickness of the slab but not less than 4 cm in any case. The joint may be formed by depressing into the soft but compacted concrete a high tensile M.S. or other approved Tee or flat bar of depth not less than required depth of the joint plus 25 mm. The bar used for forming the groove shall be coated with soft soap or other suitable lubricant to facilitate its removal when the steel Tee or flat is removed joints shall be neatly formed with proper tools and mortar/fine material from the slab itself. No additional cement mortar (rich or otherwise) shall be used.

**16.37.17.2** Cutting or sawing by a saw mounted on a movable frame and driven mechanically shall also be permitted as a method for making the joint. In this case the width may be reduced to 6 mm. any other method for making joints can be followed with the prior approval of the Engineer-in-Charge.

**16.37.17.3** In all cases, except where cutting is done with saw, the joint edges shall be bullnosed. Care should be taken to see that the edges of the grooves are not damaged.

**16.37.17.4** The grooves shall be filled with hot poured sealing compound conforming to Grade B of IS:1834. Prior to filling with sealing compound, the joints shall be cleaned by compressed air and primed with Shalijet primer or equivalent at the rate specified in Para 16.37.16.1

**16.37.17.5** All joints shall be sealed as soon as practicable after 28 days of casting of cc pavement. Joints shall be sealed flush with the adjacent pavement surface in summer and 3-4 mm below finished concrete surface in winter. The pavement shall be opened to traffic only after joint sealing over the entire pavement. To prevent tackiness or pickup under traffic, the exposed surfaces of the sealing compound shall be dusted with hydrated lime, if directed by Engineer-in-Charge, for which nothing extra shall be paid to the contractor.

**16.37.17.6** In case of sudden rain or storm, the work can be concluded at the dummy joints but these will then be formed as construction joints.

**16.37.17.7** Before sealing of joints, it may be ensured that the groove extends fully across the bay between consecutive longitudinal joints, in the case of transverse joints and is continuous in the case of longitudinal joints. Any concrete or other foreign matter must be removed from the groove.

#### **16.37.18 Concreting during Rains**

**16.37.18.1** To prevent damage to freshly laid concrete during monsoon, or sudden rains, the contractor shall provide an adequate supply of tarpaulins or other water proof covering material. Any concrete damaged by rain shall be removed and replaced by the contractor at his own cost as directed by the Engineer-in-Charge.

#### **16.37.19 Quality Control**

The following quality control tests shall be carried out at frequencies specified against each as in Table 16.33.

**TABLE 16.33**

| S.No                          | Test                       | Test Method                              | Frequency   | Acceptance Criteria                 |
|-------------------------------|----------------------------|--|---|-------------------------------------|
| 1                             | 2                          | 3  | 4   | 5                                   |
| <b>(i) COARSE AGGREGATE</b>   |                            |  |   |                                     |
| (a)                           | Flakiness index            | IS 2386 (Pt.1)                           | Before approval of the quarry and at every subsequent change in the source of supply and one test per 100 cum of aggregates | Not more than 15%                   |
| (b)                           | Impact value               | IS 2386 (Pt.4)                           | -do-  | Not more than 30%                   |
| (c)                           | Los angles abrasion value. | IS 2386 (Pt.4)                           | -do-  | Not more than 40%                   |
| (d)                           | Deleterious materials.     | IS 2386 (Pt.2)                           | Before approval of the quarry and at every subsequent change in the source of supply  | As per table 1 of IS 383            |
| (e)                           | Moisture content.          | IS 2386 (Pt.3)                           | Regularly as required subject to a min. one test per day  | -do-                                |
| <b>(ii) FINE AGGREGATES</b>   |                            |  |   |                                     |
| (a)                           | Silt content.              | CPWD specifications 2019, Vol. I, SH: CC | One test per 15 cum   | Not more than 8%                    |
| (b)                           | Gradation of sand          | IS 2386 (Pt.1)                           | -do-  | Fineness modulus between 2.5 to 3.9 |
| (c)                           | Deleterious materials.     | IS 2386 (Pt.2)                           | Before approval of the quarry and at every subsequent change in the source of supply  | As per table 1 of IS 383            |
| (d)                           | Moisture content.          | IS 2386 (Pt.3)                           | Regularly as required subject to a min. 2 test/day  | -do-                                |
| <b>(iii) MIXED AGGREGATES</b> |                            |  |   |                                     |
| (a)                           | Grading                    | IS 2386 (Pt. 1)                          | 1 test per 15 cum   | As per para 16.37.1.5               |
| (iv)                          | Slump test of concrete     | IS 1199                                  | At least once in 50 batches at each mixer or more frequently if directed by the Engineer-in-Charge                          | Not more than 25 mm                 |
| (v)                           | Flexural strength          | IS 516                                   | One test of sample consisting of eight specimen for every 30 cum of concrete  | As per para 16.37.3.5.              |
| (vi)                          | Surface accuracy           | As prescribed                            | Regularly   | As per para 16.37.13                |

**16.37.20 Equipments**

**16.37.20.1** Equipments as per list at Appendix C shall be provided by the contractor in the field testing laboratory. Nothing extra shall be paid to him on this account. Records as required shall be maintained at site. All tests details in support of mix design shall be maintained as part of records of the contract and shall be signed both by the contractor and the Engineer-in-Charge. The contractor shall provide all labour, materials and equipment required for all tests to be carried out at his own cost.

**16.37.20.2** The Engineer-in-Charge reserves the right to test any part of concrete laid regarding quality soundness, compactness, thickness, strength and finish of the concrete, at any time before the expiry of the "Defect liability period" notwithstanding that necessary tests had been carried out and found satisfactory at the time of execution.

**16.37.20.3** All defective unsound sub-standard work and concrete of sub-standard strength and quality etc. as established vide paras 16.37.3 shall be rejected and shall be replaced by the contractor at his own expense in the manner as detailed in para 16.37.3. Where due to operational or any other reason such replacement does not become possible (decision of Engineer-in-Charge in this respect being final and binding on the contractor), the cost of removal and replacement of such rejected work shall be recovered from the contractor whether such rejected work is subsequently replaced by the Government or not.

#### **16.37.21 Defects Liability Period**

**16.37.21.1** This period shall be reckoned in the case of this work as one year from the date of completion of work and it shall be the liability of the contractor to repair, strengthen or reconstruct any portion of the work which has shown damage or any defect, arising out of any bad workmanship or defective material used in the work during this period. In the case of this rectification not being commenced by the contractor within 7 days from the date of notice from the Engineer-in-Charge and completed expeditiously the Engineer-in-Charge reserves the right to get the repair work executed at the risk and cost of the contractor.

#### **16.37.22 Measurements**

**16.37.22.1** For the purpose of ascertaining the quantity of concrete in the pavement, thickness shall be measured by means of a scale correct to the nearest 2 mm. The thickness of the concrete pavement slabs shall be taken on either side of the pavement at each dummy joint at four corners of the slab immediately after removal of the side forms. In case the average thickness of the slab exceeds the specified thickness, payment shall be restricted to the specified thickness.

**16.37.22.2** The dimensions of each slab of pavement shall be measured as follows to the nearest 5 mm.

##### **(a) Length**

- (i) Between the end of a pavement to the centre line of the expansion joints.
- (ii) Between the centre lines of consecutive expansion joints.

##### **(b) Width**

- (i) Between the edge of a pavement and the centre line of the construction joints.
- (ii) Between the centre lines of construction joints and expansion joints.
- (iii) Between the centre lines of consecutive construction joints.

**Note :** The quantity of concrete in the pavement slab shall be worked out by multiplying the area of the slab and its average thickness or specified thickness whichever is less. No deduction shall be made for any joints in the concrete slab.

**16.37.22.3** Measurements of concrete slabs shall be recorded jointly by the Engineer-in-Charge or his authorised subordinate and the contractor or his authorised agent.

#### **16.37.23 Rate**

The rate of the item for concrete in pavement shall include the cost of all materials and labour including charges for machinery tools & plants required in all the operations described above. The rate also includes all cost of setting up the laboratory at site and carrying out the quality control measures/tests enumerated above by the contractor at his own cost in the presence of Engineer-in-Charge or his authorized representative and submission of test results on completion of tests to the Engineer-in-Charge thereof.

### **16.38 HARD CRETE**

Hard crete of approved quality and brand to be used. It shall be mixed in ratio and method as recommended by manufacturer and approved by Engineer-in-charge in cement concrete for laying in paramount. Quantity shall be measured in litre used in cement concrete. Hardcrete to be brought in sealed container and proper record of quantity be maintained. Empty containers of hardcrete shall not be removed from site with but prior permission of Engineer-in-Charge.

### **16.39 EXPANSION JOINT**

#### **16.39.0 Materials**

**Premoulded Joint Filler in Expansion Joint :** It shall conform to IS 1838 (Pt. I). The thickness shall be 25 mm with tolerance 1.5 mm. and shall be of the maximum available standard length not less than one lane width. The filler board shall be positioned vertically with the prefabricated joint assemblies along the line of the joint within tolerance of  $\pm 10$  mm from the intended line of the joint. The depth of board shall be 25 mm less than thickness of slab within a tolerance of  $\pm 3$ mm so that the top of the board shall be below the surface or will not impend the passage of the finishing straight edge or oscillating beam of the paving machine.

**Bitumine Hot Sealing Compound :** The joint sealing compound shall be fuel and heat resistant type complying to grade B of IS 1834. It shall be capable of adhering to the concrete without cracking, spalling and disintegration.

#### **16.40 CONSTRUCTION PROCEDURE**

**16.40.1** Expansion joints shall be provided as shown in the drawing and as per directions of Engineer-in-Charge. All joints shall be constructed true to line with their faces perpendicular to the surface of the pavement. The joint shall be 20 mm wide. The depth of the non-extruding filler pad shall be 25 mm less than the depth of the concrete slab.

**16.40.2** Before the provision of expansion joint, the face of the already laid concrete slab shall be painted with primer at the rate of 2.6 liters per 10 square metres. The expansion pad shall be properly cut to shape and shall then be placed in position abutting the painted face of the already laid concrete slab. The adjacent slab shall then be concreted. The face of the pad against which the new concrete slab is to be laid shall also be painted with primer before laying the concrete, while concreting a neat groove of size 20 mm x 25 mm as per drawing shall be formed on top of the pad taking care that the edges are absolutely straight and that the groove so made does not get filled with any material like concrete, mortar and other rubbish.

**16.40.3** Before the curing process is started, the top of expansion joint shall be filled with bitumen sand mixture in order to ensure that no foreign material used in curing enters into the joint. This filling shall be removed before filling the joints with sealing compound.

**16.40.3.1** For sealing the joints following operations shall be carried out :—

- (a) The joints are cleared of any foreign matter to the full depth upto the top of expansion pad with steel spatula.
- (b) The joints are blown with compressed air.
- (c) Cleaning is done with Kerosene oil.
- (d) Priming is done with spray gun @ 2.6 liters per 10 sqm of the surface to be primed.
- (e) The primer is allowed to dry completely before pouring the sealing compound.
- (f) The sealing compound grade 'A' is heated to the required temperature ranging between 155 deg. C to 165 deg. C or to the temperature range specified by the manufacturer. Over



heating shall be avoided. Pouring shall be done from vessel with spout in such a manner that the material will not get spilled on the exposed surface of the concrete, any excess filler on the surface of the pavement shall be removed immediately and the pavement surface cleaned.

- (g) The filling shall be worked into the joints with hot flats to ensure escape of trapped air.
- (h) The filling is then ironed with hot iron. It is recommended that while in summer the joints may be sealed flush with the adjacent pavement surface, in winter the sealing compound may be filled to a depth 3-4 mm below the surface.
- (i) The edges of the joints are then cut and trimmed to ensure neat and straight line finish.
- (j) To prevent tackiness or pick up under traffic, the exposed surfaces of the sealing compound shall be dusted with hydrated lime, if directed by Engineer-in-Charge (Nothing extra shall be paid for the same).

**16.40.3.2 Measurements :** The measurement of the specified depth of joint shall be recorded in metres correct to two places of decimals.

#### **16.40.4 Rate**

Rate for the item shall include the cost of all materials, plant, machinery and labour involved in all operations described above, including all cartages and lifts.

### **16.41 PAINTING ROAD/ RUNWAYS MARKINGS**

#### **16.41.1 Materials**

**16.41.1.1** Special Road marking paint of approved brand and manufacture shall be used. The paint shall conform to IS 164. Ready mixed paint as received from the manufacturer shall be used without adding any admixture.

**16.41.1.2** During work, if the consistency of the paint gets thick and thinning becomes necessary it shall be done by use of thinner of the approved brand of paint recommended by the manufacturer and with the approval of the Engineer-in-Charge.

**16.41.1.3** The paint shall be brought to the site of work by the contractor in original sealed containers. The material shall be brought in one lot in adequate quantity to suffice for the entire work. The material shall be kept in the joint custody of the contractor and the Engineer-in-Charge. The empty container shall not be removed from the site of work, till the work has been completed and permission obtained from the Engineer-in-Charge.

#### **16.41.2 Preparation of Surface**

The surface shall be thoroughly cleaned and free from dust. All the dirt, scales, oil and grease shall be thoroughly removed before painting is started. The prepared surface shall be inspected and approved by the Engineer-in-Charge before painting is commenced.

#### **16.41.3 Application**

**16.41.3.1** Before pouring into smaller containers for use, the paint shall be stirred thoroughly in its original container. The paint shall be continuously stirred in the smaller container while applying to runway surface so that its consistency is kept uniform.

**16.41.3.2** The painting shall be applied evenly and smoothly by means of crossing and laying off. The crossing and laying off consists of covering the area over with paint, brushing the surface hard for the first time over and then brushing alternatively in opposite direction, two or three times and then finally brushing lightly in a direction at right angle to the same. In this process, no brush marks shall be left after the laying off is finished. The full process of crossing and laying off will constitute one coat.



**16.41.3.3** Each coat shall be allowed to dry out thoroughly before the next coat is applied.

**16.41.3.4** Earlier applied coat shall be cleaned off dust before the next coat is laid.

**16.41.3.5** No left over paint shall be put back into the stock tins. When not in use, the containers shall be kept properly closed.

**16.41.3.6** No hair marks from the brush or clogging of paint puddles shall be left on the work.

**16.41.3.7** The surface shall ordinarily not be painted until it has dried up completely. Trial patches of paint shall be laid at intervals to check if drying is satisfactory.

**16.41.3.8** The runway marking shall be done in accordance with the drawing unless otherwise instructed by the Engineer-in-Charge.

#### **16.41.4 Brushes and Containers**

**16.41.4.1** After work, the brushes shall be completely cleaned of paint by rinsing with turpentine. A brush in which paint has dried up is spoiled and shall on no account be reused for painting work. On no account kerosene oil shall be used for washing the brush.

**16.41.4.2** When the paint has been used, the containers shall be washed with turpentine and wiped dry with soft clean cloth so that they are clean, and can be used again.

#### **16.41.5 Measurement**

**16.41.5.1** Length and breadth shall be measured correct to a cm. Area shall be worked out in square metre, correct to two places of a decimal.

#### **16.41.6 Rate**

**16.41.6.1** Rate shall include cost of all materials, tools and labour involved in all the operations described above including all cartages and lifts.

### **16.42 PAINTING ROAD SURFACE (WITH READY MIXED ROAD MARKING PAINT)**

Specifications of item no. 16.41 to be followed except that road surface to be painted with ready mixed road marking paint of approved brand instead of paint of superior make.

### **16.43 LIME FLY ASH STABILISED SOIL SUB BASE**

**16.43.1** The thickness of lime flyash soil layer for use as sub base should be designed in accordance with IRC 37. The minimum thickness shall not be less than 15 cm.

#### **16.43.2 Soil**

Granular soils free from high concentration of organic matter or deleterious salts and sand with fine silts produce better mixes than fine grained soil with high clay content. Clay, silts and low plastic clays with plasticity index between 5 and 20 and liquid limit less than 25 are however, suitable the minimum proportion of particles smaller than 425 micron should be between 15 and 25 percent by dry weight of the soil lime flyash mixture. Selection of material and their gradation should be such as would be conducive to compaction to high density.

#### **16.43.3 Lime**

Should be commercial dry lime slaked at site or pre-slaked and delivered in airtight sacks. Suitable approved lime should have purity (CaO content) of not less than 50 percent. Only hydrated high calcium and mono hydration dolomitic limes are to be used. Quick lime is not recommended for use. Where in exceptional circumstances, when with 50% purity is not available, the deficiency can be compensated by using larger proportion of lime.

#### 16.43.4 Flyash

Shall conform to IS 3812. If it is partially set due to long storage, it should be pulverised and dry sieved before mixing, to conform to following grading.

| <i>Sieve Size mm)</i> | <i>Percent passing</i> |
|-----------------------|------------------------|
| 12.5                  | 100                    |
| 9.5                   | 95 (min)               |
| 2.0                   | 75 (min)               |

Flyash should be fine enough to have a specific surface are of 3200 sq.cm/gm or 320 sqm/kg. It should be ensured before its use, that flyash possesses lime relativity of not less than 35 kg/sq.cm. Flyash should be stored in covered area safe from moisture.

#### 16.43.5 Mix Proportioning

The mix proportion shall be determined in conformity with IRC -88 through laboratory tests for meeting the strength requirements. A typical mix proportion of soil lime, flyash is given below :

- Soil 85 parts by weight
- Lime 3 parts by weight  
(based on 80% purity of lime)
- Flyash 12 parts by weight

#### 16.43.6 Tolerance

Limits of tolerance for various materials in percentage by weight shall be as follows

|        |       |
|--------|-------|
| Lime   | ± 0.3 |
| Flyash | ± 1.5 |
| Soil   | ± 2.0 |

#### 16.43.7 Surface Irregularities

The finish surface should be checked for line, level and grade and surface finish. The maximum permissible undulation in longitudinal profile shall not exceed 15 mm when checked with 3 metre straight edge and in cross profile the variation from specified profile shall not exceed 12 mm.

The quantity of water shall be as per the O.M.C. requirements determined on soil lime flyash mixture by proctor density method.

#### 16.43.8 Construction Operation

Mixing shall preferably be done by mechanical plant either of the single pass or multiple pass type, where such plant is not available, manual method may be adopted with rigorous control over quality of construction. In the manual method, the soil shall be pulverised by means of crowbars, pick axes, bullock drawn ploughs etc. and deposited on the road bed in stacks of suitable size, about 30 cm in height. Water in requisite quantities shall be sprinkled on the soil for aiding pulverisation. The degree of pulverisation shall be as given in Table 16.34.

**TABLE 16.34**

| <i>Sieve Designation</i> | <i>% by weight passing the sieve.</i> |
|--------------------------|---------------------------------------|
| 25 mm                    | 100                                   |
| 4.75 mm                  | 60                                    |

On the pulverised soil stacks, lime and flyash in a thoroughly mixed form and in the requisite quantities shall be spread uniformly and mixed by cutting with spade till the whole mass is uniform. The mixed soil shall then be spread over the prepared sub-grade to the required thickness and rolled. Before rolling, the moisture content shall be adjusted to be within + 1% and -2% of the O.M.C.

#### **16.43.9 Rolling**

Rolling shall be done with a 8-10 tonne roller. Rolling is continued till the required density (100% of Lab. Proctor density as per IS 2720 Pt.VII) and a smooth surface obtained without leaving any roller marks on the surface. During rolling surface should be checked for grade and camber and irregularities corrected.

#### **16.43.10 Curing**

The compacted surface shall be cured for a minimum period of 7 days before the next layer is placed. Curing is done by sprinkling water over the surface five or six times a day. The surface shall not be allowed to dry during the curing period. Curing by ponding shall not be adopted.

#### **16.43.11 Measurements**

The length and breadth shall be taken to the nearest centimeter and the thickness to the nearest half centimeter. The consolidated cubical contents shall be calculated in cubic metres, correct to two places of decimals.

#### **16.43.12 Rate**

The rate shall include the cost of materials and labour involved in all the operations described above.

### **16.44 PRECAST LIME FLY ASH CONCRETE BLOCKS**

#### **16.44.1 Material**

Precast lime fly ash concrete blocks 1:2:3:6 (1 lime : 2 fly ash : 3 coarse sand : 6 graded stone aggregate 20 mm nominal size) finished with 10 mm, thick cement mortar 1:3 (1 cement : 3 coarse sand).

**16.44.1.1 Laying** : Prepare the sub grade with a hand rammer and laying 10 mm thick levelling course of fine sand (Jamuna sand). Laying the precast lime flyash concrete blocks as specified over base as described above and filling the joints with fine sand.

#### **16.44.2 Measurement**

Length breadth & thickness of block shall be measured of finished work. Correct to a cm. and calculated in cubic metre. Correct to two decimal places.

#### **16.44.3 Rate**

The rate shall include the cost of material & labour involved in all operations described above.

### **16.45 CONCERTINA COIL FENCING**

**16.45.1 Material** : Angle iron post & strut shall be as specified in 16.18.

Concertina coil fencing shall be dia 610 mm (having 15 nos round per 6 mtre. length), spring core (2.5 mm thick) wire of high tensile strength of 165 kg./sq.mm with tape (0.52 mm thick) and weight 43.478 gm/metre.

**16.45.2 Spacing of Posts & Struts:** The spacing of posts shall be 2.4 m or 3.00 m apart centre to centre, unless otherwise specified or as per Engineer-in -Charge to suit the dimension of the area to be fenced. Every 15th last but one end posts and corner posts shall be strutted on both sides and end posts on one side only.

**16.45.3 Fixing of Posts and Struts :** As specified in the 16.17.3.

**16.45.4** Fixing Concertina coil fencing shall be fixed on angle iron shaped with 9 horizontal reinforced barbed tape (RBT) stud tied with GI staples and GI clips to retain horizontal including necessary bolts or GI barbed wire tied to angle iron all complete as per directions of Engineer-in-Charge with reinforced barbed tape.

**16.45.5 Measurements**

The length of fencing shall be measured correct to a cm. for finished work.

**16.45.6 Rate**

The rate shall include the cost of labour and materials involved in all the operation described above but excluding the cost of M.S. angle and excavation and concrete in foundation for which separate payment shall be made under respective items.

**16.46 DENSE GRADED BITUMINOUS MACADAM (DBM)**

**16.46.1 Scope**

Dense Bituminous Macadam (DBM) for use mainly but not exclusively, for in base/binder and profile corrective courses. DBM is also used as road base material. This work shall consist of construction in a single or multiple layers of DBM on a previously prepared base or sub-base. The thickness of a single layer shall be 50 mm to 100 mm.

**16.46.2 Material**

**16.46.2.1 Bitumen :** The bitumen shall be viscosity grade paving bitumen complying with the Indian Standard Specification IS:73, or as otherwise specified in the item. The type and grade of bitumen to be used shall be specified in the item of Contract. Where modified bitumen is specified, it shall conform to the requirements of IRC:SP:53 and IS:15462.

Section criteria for viscosity grade bitumen, based on highest and lowest daily mean temperatures at a particular site are given in **Table 16.40A**.

Selection criteria for modified bitumen shall be in accordance with IRC:SP53.

**16.46.2.2 Coarse Aggregates :** The coarse aggregates shall consist of crushed rock, crushed gravel or other hard material retained on the 2.36 mm IS Sieve. They shall be clean, hard, durable, or cubical shape, free from dust and soft or friable matter, organic or other deleterious substance. Before approval of the source, the aggregates shall be tested for stripping. The aggregates shall satisfy the physical requirements specified in **Table 16.35**, for dense bituminous macadam.

Where crushed gravel is proposed for use as aggregate, not less than 90% by weight of the crushed material retained on the 4.75 mm IS Sieve shall have at least two fractured faces.

**16.46.2.3 Fine Aggregates :** Fine aggregates shall consist of crushed or naturally occurring mineral material, or a combination of the two, passing the 2.36 mm IS Sieve and retained on the 75 micron sieve. These shall be clean, hard, durable, dry and free from dust and soft or friable matter, organic or other deleterious matter. Natural sand shall not be allowed in binder courses. However, natural sand upto 50 percent of the fine aggregate may be allowed in base courses.

The fine aggregate shall have a sand equivalent value of not less than 50 when tested in accordance with the requirements of IS 2720 (Part 37).

The plasticity index of the fraction passing the 0.425 mm IS Sieve shall not exceed 4, when tested in accordance with IS 2720 (Part 5).

**TABLE 16.35**  
**Physical Requirements for Coarse Aggregate for Dense Bituminous Macadam**

| <i>Property</i>    | <i>Test</i>  | <i>Specification</i>          | <i>Method of Test</i> |
|--------------------|--|-------------------------------|-----------------------|
| Cleanliness (dust) | Grain size analysis <sup>7</sup>                                 | Max 5% passing 0.075mm sieve. | IS:2386 Part 1        |
| Particle shape     | Combined Flakiness and Elongation Indices*                       | Max 35%                       | IS:2386 Part 1        |
| Strength           | Los Angeles Abrasion Value<br>or<br>Aggregate Impact Value       | Max 35%<br>Max 27%            | IS:2386 Part 4        |
| Durability         | Soundness either:<br>Sodium Sulphate<br>or<br>Magnesium Sulphate | Max 12%<br>Max 18%            | IS:2386 Part 5        |
| Water Absorption   | Water Absorption   | Max 2%                        | IS:2386 Part 3        |
| Stripping          | Coating and stripping of Bitumen aggregate Mix                   | Minimum retained coating 95%  | IS:6241               |
| Water sensitivity  | Retained Tensile Strength**                                      | Min 80%                       | AASHTO 283            |

\* To determine this combined proportion, the flaky stone from a representative sample should first be separated out. Flakiness index is weight of flaky stone metal divided by weight of stone sample. Only the elongated particles be separated out from the remaining (non-flaky) stone metal. Elongation index is weight of elongated particles divided by total non-flaky particles. The values of flakiness index and elongation index so found are added up.

\*\* If the minimum retained tensile test strength falls below 80 percent, use of anti stripping agent is recommended to meet the requirement.

**16.46.2.4 Filler :** Filler shall consist of finely divided mineral matter such as rock dust, hydrated lime or cement approved by the Engineer-in-Charge. The filler shall be graded within the limits indicated in **Table 16.36**.

**TABLE 16.36**  
**Grading Requirements for Mineral Filler**

| <i>Is Sieve (mm)</i> | <i>Cumulative per cent passing by weight of total aggregate</i> |
|----------------------|---|
| 0.6                  | 100   |
| 0.3                  | 95-100  |
| 0.075                | 85-100  |

The filler shall be free from organic impurities and have a plasticity index not greater than 4. The Plasticity Index requirements shall not apply if filler is cement or lime. Where the aggregates fail to meet the requirements of the water sensitivity test in Table 16.35, then 2 percent by total weight of aggregate, of hydrated lime shall be used and percentage of fine aggregate reduced accordingly.

**16.46.2.5 Aggregate Grading and Binder Content :** When tested in accordance with IS 2386 Part 1 (wet sieving method), the combined grading of the coarse and fine aggregates and added filler for the particular mixture shall fall within the limits shown in **Table 16.37** for dense bituminous macadam. To avoid gap grading the combined aggregate grading shall not vary from the low limit on one sieve to the high limit on the adjacent sieve.

**TABLE 16.37**  
**Composition of Dense Graded Bituminous Macadam Pavement Layers**

| Mix Designation   | Grading 2   |
|---|---|
| Nominal aggregate size*                                       | 26.5 mm   |
| Layer Thickness   | 50-75 mm  |
| IS Sieve <sup>1</sup> (mm)                                    | Cumulative % by weight of total aggregate passing |
| 37.5  | 100   |
| 26.5  | 90-100  |
| 19  | 71-95   |
| 13.2  | 56-80   |
| 4.75  | 38-54   |
| 2.36  | 28-42   |
| 0.3   | 7-21  |
| 0.075   | 2-8   |
| Bitumen content percent by mass of total mix (Marshal method) | Min 4.5** or as specified in the item             |
| Bitumen grade   | As specified in item or directed otherwise.       |

\* The nominal maximum particle size is the largest specified sieve size upon which any of the aggregate is retained.

\*\* Corresponds to specific gravity of aggregates being 2.7. In case aggregate have specific gravity more than 2.7, the minimum bitumen content can be reduced proportionately. Further the region where highest daily mean air temperature is 30<sup>o</sup> C or lower and lowest daily air temperature is – 10<sup>o</sup> C or lower, the bitumen content may be increased by 0.5 percent.

**16.46.2.6** Bitumen content indicated in **Table 16.37** is the minimum quantity. The quantity shall be determined in accordance with the Mix Design. Para 16.46.3

### 16.46.3 Mix Design

The bitumen content required shall be determined following the Marshall mix design procedure contained in Asphalt Institute Manual MS-2.

The Fines to Bitumen (F/B) ratio by weight of total mix shall range from 0.6 to 1.2.

**16.46.3.1 Requirement for the Mix:** The mix shall meet the requirements as given in **Table 16.38**.

**TABLE 16.38**  
**Requirements for Dense Bituminous Macadam**

| Properties                                     | Viscosity Grade<br>Paving Bitumen   | Modified bitumen |              | Test Method            |
|--|---|------------------|--------------|------------------------|
|  |   | Hot climate      | Cold climate |                        |
| Compaction level                               | 75 blows on each face of the specimen                                       |                  |              |                        |
| Minimum stability<br>(kN at 60° C)             | 9.0   | 12.0             | 10.0         | AASHTO T245            |
| Marshall flow<br>(mm)                          | 2 – 4   | 2.5 - 4          | 3.5 - 5      | AASHTO T245            |
| Marshall Quotient<br>{ Stability }<br>{ Flow } | 2 – 5   | 2.5 - 5          |              | MS-2 and ASTM<br>D2041 |
| % air voids                                    | 3 – 5   |                  |              |                        |
| % Voids Filled with<br>Bitumen (VFB)           | 65 – 75   |                  |              |                        |
| Coating of<br>aggregate particle               | 95% Min.  |                  |              | IS:6241                |
| Tensile Strength<br>ratio                      | 80% Min.  |                  |              | AASHTO T283            |
| % Voids in Mineral<br>Aggregate (VMA)          | Minimum percent voids in mineral aggregate (VMA) are set out in Table 16.40 |                  |              |                        |

**TABLE 16.39**  
**Minimum Percent Voids in Mineral Aggregate (VMA)**

| Nominal Maximum Particle size <sup>1</sup> (mm) | Minimum VMA, Percent Related to Design<br>Percentage Air voids |      |      |
|---|--|------|------|
|   | 3.0  | 4.0  | 5.0  |
| 26.5  | 11.0   | 12.0 | 13.0 |
| 37.5  | 10.0   | 11.0 | 12.0 |

**Note:** Interpolate minimum voids in the mineral aggregate (VMA) for designed percentage air voids values between those listed.

**16.46.3.2 Binder Content :** The binder content shall be optimized to achieve the requirements of the mix set out in Table 16.38. The binder content shall be selected to obtain 4 percent air voids in the mix design. The Marshall method for determining the optimum binder content shall be adopted as described in the Asphalt Institute Manual MS-2.

Where maximum size of the aggregate is more than 26.5 mm, the modified Marshall method using 150 mm diameter specimen described in MS-2 and ASTM D 5581 shall be used. This method requires modified equipment and procedures. When the modified Marshall test is used, the specified equipment and procedures. When the modified Marshall test is used, the specified minimum stability values in Table 16.39 as above shall be multiplied by 2.25 and the minimum flow shall be 3 mm.

**16.46.3.3 Job Mix Formula :** The contractor shall inform the Engineer-in-Charge in writing, at least 21 days before the start of the work, of the job mix formula proposed for use in the works, and shall give the details of Source and location of all materials, their sizes, grading, binder type and percentage by weight of total mix, Coarse aggregate / Fine aggregate / Mineral filler as percentage by weight of total aggregate including mineral filler and Mixing temperature and compacting temperature and test results.



While establishing the job mix formula, the Contractor shall ensure that it is based on a correct and truly representative sample of the materials that will actually be used in the work and that the mix and its different ingredients satisfy the physical and strength requirements of these Specifications.

Approval of the job mix formula shall be based on independent testing by the Engineer-in-Charge for which samples of all ingredients of the mix shall be furnished by the Contractor as required by the Engineer-in-Charge.

Job mix formula shall be revised if there is a change in source of material and be got approved by Engineer-in-Charge.

**16.46.3.4 Plant Trials – Permissible Variation in Job Mix Formula:** Once the laboratory job mix formula is approved, the Contractor shall carry out plant trials at the mixer to establish that the plant can be set up to produce a uniform mix conforming to the approved job mix formula. The permissible variations of the individual percentages of the various ingredients in the actual mix from the job mix formula to be used shall be within the limits as specified in Table 16.40.

**TABLE 16.40**  
**Permissible Variations in the Actual Mix from the Job Mix Formula**

| Description                                | Permissible Variation |                |
|--|-----------------------|----------------|
|  | Base/Binder Course    | Wearing Course |
| Aggregate passing 19 mm sieve or larger    | ± 8%                  | ± 7%           |
| Aggregate passing 13.2 mm, 9.5 mm          | ± 7%                  | ± 6%           |
| Aggregate passing 4.75 mm                  | ± 6%                  | ± 5%           |
| Aggregate passing 2.36 mm, 1.18 mm, 0.6 mm | ± 5%                  | ± 4%           |
| Aggregate passing 0.3 mm, 0.15 mm          | ± 4%                  | ± 3%           |
| Aggregate passing 0.075 mm                 | ± 2%                  | ± 1.5%         |
| Binder content                             | ± 0.3%                | ± 0.3%         |
| Mixing temperature                         | ± 10°C                | ± 10°C         |

**16.46.3.5 Laying Trials :** Once the plant trials have been successfully completed and approved, the Contractor shall carry out laying trials, to demonstrate that the proposed mix can be successfully laid and compacted.

**16.46.4 Construction Operations**

**16.46.4.1 Preparation of Base :** The base on which DBM is to be laid shall be prepared, shaped and compacted to the required profile as appropriate or as directed by the Engineer-in-charge. The surface shall be thoroughly swept clean by a mechanical broom, and the dust removed by compressed air, in locations where mechanical broom cannot get access, other approved methods shall be used as directed by the Engineer-in-charge.

**16.46.4.2 Tack Coat :** Where the material on which the dense bituminous macadam is to be laid is **either** bitumen bound layer or primed granular layer, tack coat shall be applied as specified, in accordance with the provisions of **para 16.29**, or as directed by the Engineer-in-Charge.

**16.46.4.3 Mixing and Transportation of the Mixture :** The provisions are as specified in the **para 16.47.3.3** shall apply. **Table 16.41A** gives the mixing laying and rolling temperature for dense mixes using viscosity grade bitumen. In case of modified bitumen, the temperature of mixing and compaction shall be higher than the mix with viscosity grade bitumen. The exact temperature depends upon the type and amount of modifier used and shall be adopted as per the recommendations of the manufacturer. In order to have uniform quality, the plant shall be calibrated from time to time.

**16.46.4.4 Spreading :** The provisions are as specified in the **para 16.47.3.5** shall apply. The paver finisher shall be fitted with electronic sensor device.

**16.46.4.5 Rolling / Compaction & Joints :** The provisions are as specified in the **para 16.47.3.6 and 16.47.3.7** shall apply, as modified by the approved laying trials. The compaction process shall be carried out by the same plant, and using the same method, as approved in the laying trials, which may be varied only with the express approval of the Engineer-in-charge in writing.

**16.46.5 Opening to Traffic :** The newly laid surface shall not be open to traffic for at least 24 hours after laying the completion of compaction, without the approval of the Engineer-in-Charge in writing, on the surface until the DBM layer has cooled to the ambient temperature.

**16.46.6 Surface Finish and Quality Control of Work :** The surface finish of the completed construction shall conform to the requirements of section 900 of MORTH Specifications. For control of the quality of materials supplied and the works carried out the relevant provisions of Section 900 of MORTH Specifications.

**16.46.7 Arrangement for Traffic :** During the period of construction, arrangements for traffic shall be made in accordance with the provisions of specification and as per direction of the Engineer-in-charge.

**16.46.8 Measurement**

Dense Bituminous Macadam shall be measured as finished work in cubic meters, correct to two places of decimal.

**16.46.9 Rate**

The rate includes the cost of all material, labour, machineries and equipments in all the operations described above.

**16.47 BITUMINOUS MACADAM**

**16.47.1 Scope**

This work shall consist of construction in a single course having 60 mm to 100 mm thickness or in multiple courses of compacted crushed aggregates premixed with a bituminous binder on a previously prepared base to the requirements of these Specifications. Since the bituminous macadam is an open-graded mix, there is a potential that it may trap water or moisture vapour within the pavement system. Therefore, adjacent layer (shoulders) should have proper drainage quality to prevent moisture-induced damage to the BM.

**16.47.2 Material**

**16.47.2.1 Bitumen :** The bitumen shall be viscosity grade paving bitumen complying with the Indian Standard Specification IS:73, or as otherwise specified in the item. The type and grade of bitumen to be used shall be specified in the Contract. The type and grade of bitumen to be used would depend upon the climatic conditions and the traffic. Guidelines for selection of bitumen are given in **Table 16.40A**.

**Table 16.40A**  
**Selection Criteria For Viscosity-Graded (VG) Paving Bitumen Based**  
**On Climatic Conditions**

| Lowest Daily Mean Air Temperature °C | Highest Daily Mean Air Temperature, °C |            |                |
|--------------------------------------|--|------------|----------------|
|                                      | Less than 20°C                         | 20 to 30°C | More than 30°C |
| More than -10°C                      | VG-10                                  | VG-20      | VG-30          |
| -10°C or lower                       | VG-10                                  | VG-10      | VG-20          |

**16.47.2.2 Coarse Aggregates** - same as 16.46.2.2 excepting strength which shall be max 40% for Los Angeles Abrasion Value and Aggregate Impact Value of max 30%.

**16.47.2.3 Fine Aggregates** : Same as 16.46.2.3.

**16.47.2.4 Proportioning of Material:**

The combined aggregate grading shall not vary from the lower limit on one sieve to the higher limit on the adjacent sieve to avoid gap grading. The aggregate may be proportioned and blended to produce a uniform mix complying with the requirements in Table 16.41. The bitumen content and appropriate thickness are as per Table 16.41.

**TABLE 16.41  
Composite of Bituminous Macadam**

| <b>Mix Designation</b>                         | <b>Grading 2</b>                                  |
|--|---|
| Nominal maximum aggregate size*                | 19 mm   |
| Layer Thickness                                | 50-75 mm  |
| IS Sieve (mm)                                  | Cumulative % by weight of total aggregate passing |
| 26.5   | 100   |
| 19   | 90-100  |
| 13.2   | 56-88   |
| 4.75   | 16-36   |
| 2.36   | 4-19  |
| 0.3  | 2-10  |
| 0.075  | 0-8   |
| Bitumen content** percent by mass to total mix | 3.4** or as specified in the item                 |
| Bitumen grade                                  | As specified in item or directed otherwise        |

\* Nominal maximum aggregate size is the largest specified sieve size upon which any of the aggregate material is retained.

\*\* Corresponds to specific gravity of the Aggregate being 2.7. In case aggregates have specific gravity more than 2.7, bitumen content can be reduced proportionately. Further, for regions where highest daily mean air temperature is 30<sup>o</sup> C or lower and lowest daily mean air temperature is – 10<sup>o</sup> C or lower, the bitumen content may be increased by 0.5 percent.

**16.47.2.5 Aggregate Grading and Binder Content** : When tested in accordance with IS 2386 Part 1 (wet sieving method), the combined grading of the coarse and fine aggregates and added filler for the particular mixture shall fall within the limits shown in Table 16.41 for bituminous macadam.

**16.47.3 Construction Operation**

**16.47.3.1 Preparation of the Base:** The base on which bituminous macadam is to be laid shall be prepared, shaped and compacted to the required profile as appropriate, and a prime coat, shall be applied as specified, in accordance with the provisions or as directed by the Engineer-in-charge. The surface shall be thoroughly swept clean by a mechanical broom, and the dust removed by compressed air, in locations where mechanical broom cannot get access, other approved methods shall be used as directed by the Engineer-in-charge.

**16.47.3.2 Tack Coat** : Where the material on which the bituminous macadam is to be placed is bitumen bound surface, a tack coat shall be applied as specified, in accordance with **Para 16.29**, or as directed by the Engineer-in-Charge.

**16.47.3.3 Mixing and Transportation of the Mixture :** Pre-mixed bituminous materials, shall be prepared in a hot mix plant of adequate capacity and capable of yielding a mix of proper and uniform quality with thoroughly coated aggregates. Appropriate mixing temperatures are given in **Table 16.41A** of these Specifications; the difference in temperature between the binder and aggregate should at no time exceed 14°C. In order to ensure uniform quality of the mix and better coating of aggregates, the hot mix plant shall be calibrated from time to time. The essential features of the hot mix plants are given in Annex. A of IRC:27.

If a continuous type mixing plant is used, the Contractor must demonstrate by laboratory analysis that the cold feed combined grading is within the grading limits specified for that bituminous bound material. In the case of a designed job mix, the bitumen and filler content shall be derived using this combined grading.

Bituminous materials shall be transported in clean insulated vehicles, and unless otherwise agreed by the Engineer, shall be covered while in transit or awaiting tipping. Subject to the approval of the Engineer, a thin coating of diesel or lubricating oil may be applied to the interior of the vehicle to prevent sticking and to facilitate discharge of the material.

**TABLE 16.41A**  
**Mixing, Laying and Rolling Temperatures for Bituminous Mixes (Degree Celsius)**

| Bitumen Viscosity Grade | Bitumen Temperature | Aggregate Temperature | Mixed Material Temperature | Laying Temperature | *Rolling Temperature |
|-------------------------|---------------------|-----------------------|----------------------------|--------------------|----------------------|
| VG-40                   | 160-170             | 160-175               | 160-170                    | 150 Min.           | 100 Min.             |
| VG-30                   | 150-165             | 150-170               | 150-165                    | 140 Min.           | 90 Min.              |
| VG-20                   | 145-165             | 145-170               | 145-165                    | 135 Min.           | 85 Min.              |
| VG-10                   | 140-160             | 140-165               | 140-160                    | 130 Min.           | 80 Min.              |

\* Rolling must be completed before the mat cools to these minimum temperatures.

**16.47.3.4 Cleaning of Surface :** The surface on which the bituminous work is to be laid shall be cleaned of all loose and extraneous matter by means of a mechanical broom and air jet. or any other approved equipment/ method as specified in the contract. The use of a high pressure air jet from a compressor to remove dust or loose matter shall be available full time on the site, unless otherwise specified in the Contract.

**16.47.3.5 Spreading :** Prior to spreading the mix, the base shall be prepared by carrying out the required operation. Except in areas where a mechanical paver cannot get access, bituminous materials shall be spread, leveled and tamped by an approved self-propelled paving machine equipped with an electronic sensing device. The essential features of the paver finisher shall conform to Annex A of IRC:27. As soon as possible after arrival at site, the materials shall be supplied continuously to the paver and laid without delay.

The rate of delivery of material to the paver shall be regulated to enable the paver to operate continuously. The travel rate of the paver, and its method of operations, shall be adjusted to ensure an even and uniform flow of bituminous material across the screed, free from dragging, tearing and segregation of the material. In areas with restricted space where a mechanical paver cannot be used, the material shall be spread, raked and leveled with suitable hand tools by experienced staff, and compacted to the satisfaction of the Engineer-in-charge.

The minimum thickness of material laid in each paver pass shall be in accordance with the minimum values given in the relevant parts of these Specifications. When laying binder course or wearing course approaching an expansion joint of a structure, machine laying shall stop 300 mm short of the joint. The remainder of the pavement up to the joint, and the corresponding area beyond it, shall be laid by hand, and the joint or joint cavity shall be kept clear of surfacing material.

Bituminous material, with a temperature greater than 145°C, shall not be laid or deposited on bridge deck waterproofing systems, unless precautions against heat damage have been approved by the Engineer-in-charge.

**16.47.3.6 Rolling / Compaction :** Bituminous materials shall be laid and compacted in layers which enable the specified thickness, surface level, regularity requirements and compaction to be achieved.

Compaction of bituminous materials shall commence as soon as possible after laying. Compaction shall be substantially completed before the temperature falls below the minimum rolling temperatures stated in the relevant part of these Specifications. Rolling of the longitudinal joints shall be done immediately behind the paving operation. After this, rolling shall commence at the edges and progress towards the center longitudinally except that on super elevated and unidirectionally cambered portions, it shall progress from the lower to the upper edge parallel to the center line of the pavement. Rolling shall continue until all roller marks have been removed from the surface. All deficiencies in the surface after laying shall be made good by the attendants behind the paver, before initial rolling is commenced. The initial or breakdown rolling shall be done with 8 – 10 tonnes dead weight smooth-wheeled rollers. The intermediate rolling shall be done with 8 – 10 tonnes dead weight or vibratory roller or with a pneumatic tyred roller of 12 to 15 tonnes weight having nine wheels, with a tyre pressure of at least 5.6 kg/sqcm or 0.56 MPa. The finish rolling shall be done with 6 to 8 tonnes smooth wheeled tandem rollers. Rolling shall be continued until the specified density is achieved, or where no density is specified, until there is no further movement under the roller.

Where compaction is to be determined by density of cores the requirements to prove the performance of rollers shall apply in order to demonstrate that the specified density can be achieved. In such cases the Contractor shall nominate the plant, and the method by which he intends to achieve the specified level of compaction and finish at temperatures above the minimum specified rolling temperature. Laying trials shall then demonstrate the acceptability of the plant and method used.

Bituminous materials shall be rolled in a longitudinal direction, with the driven rolls nearest the paver. The roller shall first compact material adjacent to joints and then work from the lower to the upper side of the layer, overlapping on successive passes by at least one-third of the width of the rear roll or, in the case of a pneumatic-tyred roller, at least the nominal width of 300 mm.

In portions with super elevated and unidirectional camber, after the edge has been rolled, the roller shall progress from the lower to the upper edge.

Rollers should move at a speed of not more than 5 km per hour. The roller shall not be permitted to stand on pavement which has not been fully compacted, and necessary precautions shall be taken to prevent dropping of oil, grease, petrol or other foreign matter on the pavement either when the rollers are operating or standing. The wheels of rollers shall be kept moist with water, and the spray system provided with the machine shall be in good working order, to prevent the mixture from adhering to the wheels. Only sufficient moisture to prevent adhesion between the wheels of rollers and the mixture should be used. Surplus water shall not be allowed to stand on the partially compacted pavement.

**16.47.3.7 Joints :** Where joints are made, the material shall be fully compacted and the joint made flush in one of the following ways:

- (a) All joints shall be cut vertical to the full thickness of the previously laid mix. All loosened material shall be discarded and the vertical face coated with a suitable viscosity grade hot bitumen, or cold applied emulsified bitumen. While spreading the material along the joint the material spread shall overlap 25 mm to 50 mm on the previously laid mix beyond the vertical face of the joint. The thickness of the loose overlap material should be approximately a quarter more than the final compacted thickness. The overlapped mix shall be dragged back to the hot lane so that the roller can press the small excess into the hot side of the joint to obtain a high joint density.
- (b) By using two or more pavers operating in echelon, where this is practicable, and in sufficient proximity for adjacent widths to be fully compacted by continuous rolling

All longitudinal joints shall be offset at least 300 mm from parallel joints in the layer beneath or as directed, and in a layout approved by the Engineer-in-charge. Joints in the wearing course shall coincide with either the lane edge or the lane marking, whichever is appropriate. Longitudinal joints shall not be situated in wheel track zones.

**16.47.3.8 Opening to Traffic :** The newly laid surface shall not be open to traffic for at least 24 hours after laying the completion of compaction, without the approval of the Engineer-in-Charge in writing.

**16.47.3.9 Surface Finish and Quality Control of Work :** The surface finish of the completed construction shall conform to the requirements of section 900 of MORTH Specifications. For control of the quality of materials supplied and the works carried out the relevant provisions of Section 900 of MORTH Specifications.

**16.47.3.10 Arrangement for Traffic :** During the period of construction, arrangements for traffic shall be made in accordance with the provisions of specification and as per direction of the Engineer-in-charge.

**16.47.4 Measurement :** Bituminous Macadam shall be measured as finished work in cubic meters correct to two places of decimal.

**16.47.5 Rate :** The rate includes the cost of all material, labour, machineries and equipments in all the operations described above.

## **16.48 DENSE BITUMINOUS CONCRETE**

### **16.48.1 Scope**

Dense Bituminous Concrete (DBC), is used in wearing and profile corrective courses. This work shall consist of construction in a single layer of bituminous concrete on a previously prepared bituminous bound surface. A single layer in a single layer shall be 30 mm / 40 mm / 50 mm thick.

### **16.48.2 Materials**

**16.48.2.1 Bitumen:** The bitumen shall be viscosity grade paving bitumen complying with the Indian Standard Specification IS:73, or as otherwise specified in the item. The type and grade of bitumen to be used shall be specified in the item of Contract. Where modified bitumen is specified, it shall conform to the requirements of IRC:SP:53 and IS:15462.

Section criteria for viscosity grade bitumen, based on highest and lowest daily mean temperatures at a particular site are given in **Table 16.40A**.

Selection criteria for modified bitumen shall be in accordance with IRC:SP53.

**16.48.2.2 Coarse Aggregates :** Same as specified in para 16.46.2.2 excepting strength which shall be max 30% for Los Angeles Abrasion Value and Aggregate Impact Value of max 24%. Where crushed gravel is proposed for use as aggregate, not less than 95 percent by weight of the crushed material retained on the 4.75 mm sieve shall have at least two fractured faces.

**16.48.2.3 Fine Aggregates :** The fine aggregates shall be all as specified in para 16.46.2.3.

**16.48.2.4 Filler :** Filler shall be generally as specified in para 16.46.2.4.

**16.48.2.5 Aggregate Grading and Binder Content :** When tested in accordance with IS 2386 part 1 (wet grading method), the combined grading of the coarse and fine aggregates and added filler shall fall within the limits shown in Table No. 16.42 for grading 1 or 2 specified in the contract.



**TABLE NO. 16.42**  
**Composition of Bituminous Concrete Pavement Layers**

| <b>Grading</b>                         | <b>1</b>  | <b>2</b>                                |
|--|---|---|
| Nominal aggregate size*                | 19 mm   | 13.2 mm                                 |
| Layer Thickness                        | 50 mm   | 30-40 mm                                |
| IS Sieve <sup>1</sup> (mm)             | Cumulative % by weight of total aggregate passing |   |
| 45                                     | -   | -                                       |
| 37.5                                   | -   | -                                       |
| 26.5                                   | 100   | -                                       |
| 19                                     | 90-100  | 100                                     |
| 13.2                                   | 59-79   | 90-100                                  |
| 9.5                                    | 52-72   | 70-88                                   |
| 4.75                                   | 35-55   | 53-71                                   |
| 2.36                                   | 28-44   | 42-58                                   |
| 1.18                                   | 20-34   | 34-48                                   |
| 0.6                                    | 15-27   | 26-38                                   |
| 0.3                                    | 10-20   | 18-28                                   |
| 0.15                                   | 5-13  | 12-20                                   |
| 0.075                                  | 2-8   | 4-10                                    |
| Bitumen content % by mass of total mix | Min. 5.2* or as specified in the item             | Min. 5.4** or as specified in the item  |
| Bitumen grade                          | Specified in item or directed otherwise           | Specified in item or directed otherwise |

\* The nominal maximum particle size is the largest specified sieve size upon which any of the aggregate is retained.

\*\* Corresponds to specific gravity of aggregates being 2.7. In case aggregate have specific gravity more than 2.7, the minimum bitumen content can be reduced proportionately. Further the region where highest daily mean air temperature is 30° C or lower and lowest daily air temperature is – 10 ° C or lower, the bitumen content may be increased by 0.5 percent.

### 16.48.3 Mix Design

The bitumen content required shall be determined following the Marshall mix design procedure contained in Asphalt Institute Manual MS-2.

The Fines to Bitumen (F/B) ratio by weight of total mix shall range from 0.6 to 1.2.

**16.48.3.1 Requirements for the Mix :** Same as specified in **Para 16.46.3.1** shall apply.

**16.48.3.2 Binder Content :** Same as specified in **para 16.46.3.2**.

**16.48.3.3 Job Mix Formula :** The procedure for formulating the job mix formula shall be generally as specified in **Para 16.46.3.3**.

**16.48.3.4 Plant Trials – Permissible Variation In Job Mix Formula :** The requirements for plant trials shall be as specified in **Para 16.46.3.4** and permissible limit for variation as given in **Table 16.43**.



**TABLE 16.43**  
**Permissible Variations in the Plant Mix from the Job Mix Formula**

| <i>Description</i>                         | <i>Permissible Variation</i> |
|--|------------------------------|
| Aggregate passing 19 mm sieve or larger    | ± 7%                         |
| Aggregate passing 13.2 mm, 9.5 mm          | ± 6%                         |
| Aggregate passing 4.75 mm                  | ± 5%                         |
| Aggregate passing 2.36 mm, 1.18 mm, 0.6 mm | ± 4%                         |
| Aggregate passing 0.3 mm, 0.15 mm          | ± 3%                         |
| Aggregate passing 0.075 mm                 | ± 1.5%                       |
| Binder content                             | ± 0.3%                       |
| Mixing temperature                         | ± 10°C                       |

**16.48.3.5 Laying Trials :** The requirements for laying trials be as specified in **Para 16.46.3.5**. The compacted layers of bituminous concrete (BC) shall have a minimum field density equal to or more than 92 percent of the average theoretical maximum specific gravity (G<sub>mm</sub>) obtained on the day of compaction in accordance with ASTM D2041.

**16.48.4 Construction Operations**

**16.48.4.1 Preparation of Base :** The base on which DBC is to be laid shall be prepared, shaped and compacted to the required profile as appropriate or as directed by the Engineer-in-charge. The surface shall be thoroughly swept clean by a mechanical broom, and the dust removed by compressed air, in locations where mechanical broom cannot get access, other approved methods shall be used as directed by the Engineer-in-charge.

**16.48.4.2 Tack Coat :** Where the material on which the bituminous macadam is to be placed is bitumen bound surface, a tack coat shall be applied as specified, in accordance with **Para 16.29**, or as directed by the Engineer-in-Charge..

**16.48.4.3 Mixing and Transportation of the Mixture :** The provisions are same as specified in **Para 16.47.3.3** shall apply.

**16.48.4.4 Spreading :** The provisions are same as specified in **Para 16.47.3.5** shall apply.

**16.48.4.5 Rolling / Compaction :** The provisions are same as specified in **Para 16.47.3.6** shall apply.

**16.48.5 Opening to Traffic :** The newly laid surface shall not be open to traffic for at least 24 hours after laying the completion of compaction, without the approval of the Engineer-in-Charge in writing.

**16.48.6 Surface Finish and Quality Control of Work :** The surface finish of the completed construction shall conform to the requirements of section 900 of MORTH Specifications. For control of the quality of materials supplied and the works carried out the relevant provisions of Section 900 of MORTH Specifications

**16.48.7 Arrangement for Traffic :** During the period of construction, arrangements for traffic shall be made in accordance with the provisions of specification and as per direction of the Engineer-in-charge.

**16.48.8 Measurement**

Dense Bituminous Concrete shall be measured as finished work in cubic meters, correct to two places of decimal.

### **16.48.9 Rate**

The rate includes the cost of all material, labour, machineries and equipments in all the operations described above.

## **16.49 RETRO REFLECTIVE SIGN BOARD**

### **16.49.0 General**

The colour, configuration, size and location of all the traffic signs for highways other than Express ways shall be in accordance with the code of practice for road signs, IRC:67 or as shown on the drawings. For expressways, the size of the signage, letters and their placement shall be as specified in the contract drawings and relevant specifications or as directed by the Engineer-in-Charge.

### **16.49.1 Materials**

#### **16.49.1.1 Concrete**

Concrete shall be of M-25 grade.

#### **16.49.1.2 Reinforcing steel**

Reinforcing steel shall confirm to the requirement of IS 1786 unless otherwise specified.

#### **16.49.1.3 Bolts Nuts and Washers**

High strength bolts shall confirm to IS 1367 whereas precision bolts, nuts etc. shall confirm to IS 1364.

#### **16.49.1.4 Plates and Supports**

Plates and support sections for the sign posts shall confirm to IS 226 and IS 2062 or any other stated IS specification.

#### **16.49.1.5 Substrata**

The substrate shall be either aluminium sheeting or aluminium composite material (ACM) confirming to following sub-sections.

##### **16.49.1.5.1 Aluminium**

Aluminium sheets used for sign boards shall be of smooth, hard and corrosion resistant aluminium alloy confirming to IS 736 material designation 24345 or 1900.

##### **16.49.1.5.2 Aluminium composite materials**

- (i) The Aluminum Composite Material (ACM), used as the substrate for signage application shall have a thickness of at least 4.0mm (excluding coating thickness).
- (ii) The ACM shall be composed of thermoplastic core of 'Low Density Polyethylene' (LDPE) of 3.0mm thickness sandwiched between two thick sheets of aluminium, of 3003 grade and H-18 temper and minimum thickness of 0.5mm each. The retro reflection sheeting must be applied on the top surface with aluminium surface with recommended surface preparation from sheeting manufactures.
- (iii) A fluorocarbon coating may be applied over the exposed surface of aluminum to ensure corrosion resistance and weather proof and thus shall confirm to relevant ASTM.
- (iv) The ACM shall have a high-surface energy coating on the top surface, over which the retro reflective sheeting shall be applied.
- (v) When measured after 24 hrs after application, the 90 peel-adhesion strength of the top surface of ACM with the retro reflective sheeting applied on it using a 2kg roller as per ASTM D3330 shall be at least 1.5 kg-f.

- (vi) The front surface shall have no other coating other than the high-surface energy coating and shall be protected with a self-adhesive peel-off film. The retro reflective sheeting shall be applied only on the top surface with high-surface energy coating.
- (vii) On the back surface, it shall have a polyester based service coating preferably grey in color to protect against possible corrosion and to avoid undesired glare from the rear side of the sign.
- (viii) The mechanical properties of 4mm ACM and that of its aluminium skim shall confirm to the requirement given in table 16.44 below. When tested accordance with the test methods mentioned against each of them.

**Table 16.44  
Specification for Aluminium Composite Material (ACM)**

| S. No.   | Description   | Specification for 4mm |  |
|----------|---|-----------------------|--|
|          |   | Standard Test         | Acceptable Value/Results   |
| <b>A</b> | <b>Physical Tests for ACM</b>   |                       |  |
| 1        | Over all thickness of ACM   | Measurement           | 4mm (Tolerance + 0.2mm)  |
| 2        | Aluminium Skin thickness (each side)  | Measurement           | 0.5mm (Tolerance +/- 0.03mm)   |
|          | Panel weight (ACM)  | Measurement           | 5.5 Kg/m <sup>2</sup> (+ 5%)   |
| <b>B</b> | <b>Mechanical Properties of ACM</b>   |                       |  |
| 1        | Peel off strength with retro reflective sheeting. (Drum Peel Test)  | ASTM D903             | Min. 4 N/mm  |
| 2        | Tensile strength  | ASTM E638             | Min. 40 N/mm <sup>2</sup>  |
| 3        | 0.2% Proof Stress   | ASTM E638             | Min. 34 N/mm <sup>2</sup>  |
| 4        | Elongation  | ASTM E638             | Min. 6%  |
| 5        | Flexural strength   | ASTM C393             | Min. 130 N/mm <sup>2</sup>   |
| 5        | Shear strength with punch shear test  | ASSTM D732            | Min. 18 N/mm <sup>2</sup>  |
| <b>C</b> | <b>Properties of Aluminium skin</b>   |                       |  |
| 1        | Tensile strength (Rm)   | ASTM E8               | Min. 150 N/mm <sup>2</sup>   |
| 2        | Modules of elasticity   | ASTM E8               | Min 70000 N/mm <sup>2</sup>  |
| 3        | Elongation  | ASTM E8               | Min. 2%  |
| 4        | 0.2% proof stress   | ASTM E8               | Min. 110 N/mm <sup>2</sup>   |
| <b>D</b> | <b>Properties of High surface energy coating</b>  |                       |  |
| 1        | (90 deg) Peel adhesion strength of Retroreflective sheeting on ACM surface with high-surface energy coating | ASTM D330             | Min. of 1.5 kgf<br>i.e. Equal to or more than that with surface prepared aluminium |

#### 16.49.1.5.3 Performance Certificate

Requisite performance certificate from the manufacturer of the ACM stating compliance with ACM technical specification as per Table 16.44 above shall be submitted by the contractor to the Engineer-in-Charge.

#### 16.49.1.6 *Retro- Reflective Sheeting (Type-XI Prismatic Grade sheeting):* (AS per IRC 67-2012 Clause 6.7)

The retro reflective sheeting used on the signs shall consist of white or coloured sheeting having a smooth outer surface which has the property of retro reflection over its entire surface. It shall be weather resistant and exhibit colour fastness. It shall be new and unused and show no evidence of cracking, scaling, and pitting, blistering, edge lifting or curling and shall have negligible shrinkage or expansion. A certificate of having the sheeting tested for coefficient of retro reflection, daytime colour

and luminance, shrinkage, flexibility, liner removal, adhesion, impact resistance, specular gloss and fungus resistance, 3 years outdoor weathering and its having passed these tests shall be obtained from International / Government Laboratory / Institute by the manufacturer of the sheeting and in case the certificate is obtained from international agency, it should also be obtained from Indian agency within 3 years of launching of product by the manufacture in abroad. Alternatively, a certificate conforming to ASTM Specification (D 4956-09) on artificial accelerated weathering requirements from a reputed laboratory in India can be accepted provisionally. In such a situation, the Employer/ Client, if so desires, could seek for a performance guarantee which would be released after receipt of certificate meeting the requirement of three years outdoor weathering of the sheeting.

Retro-reflective sheeting is typically manufactured as a cube corner. The reflective sheeting shall be retro-reflective sheeting made of micro prismatic retro-reflective material. The retro-reflecting surface after cleaning with soap and water and in dry condition shall have minimum co-efficient of retro reflection (determined in accordance with ASTM D4956-09) confirming to IRC:67 Table 6.9.

When totally wet, the sheeting shall not show less than 90 per cent of the values of retro-reflection. At the end of 10 years the sheeting shall return at least 80 per cent of its original retro-reflectance.

**16.49.1.7 Adhesives :** The sheeting shall have a pressure-sensitive adhesive of the aggressive-tack type requiring no heat, solvent or other preparation for adhesion to a smooth clean surface, in a manner recommended by the sheeting manufacturer and approved by Engineer-in-Charge. The adhesive shall be protected by an easily removable liner (removable by peeling without soaking in water or other solvent) and shall be suitable for the type of material of the base plate used for the sign. The Adhesive shall form a durable bond to smooth, corrosion and weather resistant surface of the base plate such that it shall not be possible to remove the sheeting from the sign base in one piece by use of sharp instrument. The sheeting shall be applied in accordance with the manufacturers specifications.

#### **16.49.2 Installation**

**16.49.2.1** Surface to be reflectorised shall be effectively prepared to receive the retro- reflective sheeting. The Aluminium / ACP sheeting shall be de-greased either by acid or hot alkaline etching and all scale/dust removed to obtain a smooth plain surface before the application of retro-reflective sheeting. Complete sheet of the material shall be used on the signs except where it is unavoidable. Sheeting with heat-activated adhesives may be spliced with an overlap not less than 5 mm or butted with a gap not exceeding 0.75 mm. The material shall cover the sign surface evenly and shall be free from twists, cracks and folds.

**16.49.2.2** Sign posts, their foundations and sign mountings shall be so constructed as to hold these in a proper and permanent position against the normal storm wind load or displacement by vandalism. Normally, sign with an area upto 0.9 sq.m shall be mounted on a single post and for greater area two or more supports shall be provided. Sign supports shall be as specified in item or as per directions of Engineer-in-Charge. The work of foundation shall conform to relevant specification as specified.

**16.49.2.3** Backside of aluminium sheet portion shall be painted with two coats of epoxy paint. Any part and support frame with two or more coats of synthetic enamel paint.

#### **16.49.3 Performance Certificate**

Requisite performance certificate from the manufacturer of the ACM stating compliance with ACM technical specification as per Table **16.44** above shall be submitted by the contractor to the Engineer-in-Charge.

#### **16.49.4 Warranty and Durability**

The Contractor shall obtain from the manufacturer a ten year warranty as per IRC:67 for satisfactory performance including stipulated retro-reflectance of the retro-reflective sheeting, the screen printed areas and cut out sheeting and cut out durable transparent overlay film and submit the same to the Engineer-in-Charge.

Processed and applied in accordance with recommended procedures, the reflective material shall be weather resistant and following cleaning, shall show no appreciable discoloration, cracking, blistering or dimensional change and shall not have less than 50 percent of the specified minimum reflective intensity values when subjected to accelerated weathering of 1000 hours, using type E or EH Weather meter (AASHTO Designation M 268).

#### **16.49.5 Measurement**

These shall be measured in square meters upto two place of decimal.

#### **16.49.6 Rate**

The rate includes the cost of materials labour and equipments involved in all the operations described above except **16.49.1.1 to 16.49.1.4**.

### **16.50 RETRO REFLECTIVE OVERHEAD SIGNAGE**

#### **16.50.0 General**

Overhead signs may be used in lieu of, or as an adjunct to, ground signs where the situation so warrants for proper information and guidance of the road user.

The support system should be properly designed based on sound engineering principles, to safely sustain the dead load, live load and wind load on the completed sign system. For this purpose, the overhead signs shall be designed to withstand a wind loading of 150 kg/m<sup>2</sup> normal to the face of the sign and 30 kg/m<sup>2</sup> transverse to the face of the sign. In addition to the dead load of the structure, walkway loading of 250kg concentrated live load shall also be considered for the design of the overhead sign structure.

#### **16.50.1 Height**

Overhead signs shall provide a vertical clearance of not less than 5.5 m over the entire width of the pavement and shoulders except where a lesser vertical clearance is used for the design of other structures. The vertical clearance to overhead sign structures or supports need not to be greater than 300 mm in excess of the minimum design clearance of other structures.

#### **16.50.2 Lateral Clearance**

**16.50.2.1** The minimum clearance outside the usable roadway shoulder for expressway sign mounted at the road side or for overhead sign supports either to the right or left side of the roadways shall be 1.80 m. This minimum clearance of 1.80 m shall also apply outside of an unmountable kerb. Where practicable, a sign should not be less than 3 m from the edge of the nearest traffic lane.

**16.50.2.2** Where a median is 3.6 m or less in width, consideration should be given to spanning over both roadways without a central support. Where overhead sign supports cannot be placed at a safe distance away from the line of traffic or in an otherwise protected site, they should either be so designed as to minimize the impact forces or protect motorists adequately by a physical barrier or guard rail of suitable design.

#### **16.50.3 Number of Signs at an Overhead Installation**

In no case should there be more than three signs displayed at any one location, including regulatory or warning signs, either on the overhead structure or on its support.

#### **16.50.4 Materials for Overhead Sign and Support Structures**

**16.50.4.1** Aluminium alloy or galvanized steel to be used as truss design supports shall conform to relevant IS. These shall be of sections and type as per structural design requirements as shown on the plans.

**16.50.4.2** Plates and support sections for sign posts shall conform to IS 226 and IS 2062.

**16.50.4.3** The overhead signs shall be reflectorised with high intensity retro-reflective sheeting of encapsulated lens type.

#### **16.50.5 Size, Locations, etc of Signs**

**16.50.5.1** The size of the signs, letter and their placement shall be as specified in the Contract drawings and specifications as per direction of Engineer-in-Charge.

#### **16.50.6 Installation**

**16.50.6.1** The supporting structure and signs shall be fabricated and erected as per details given in the plans.

**16.50.6.2** Sign posts, their foundations and sign mountings shall be so constructed as to hold sign in a proper and permanent position to adequately resist swaying in the wind or displacement by vandalism.

**16.50.6.3** The work of construction of foundation for sign supports including excavation and backfill, forms, steel reinforcement, concrete and its placement shall conform to the relevant specifications given in this specification.

**16.50.6.4** The structures shall be erected with the specified camber and in such a manner as to prevent excessive stresses, injury and defacement.

**16.50.6.5** Brackets shall be provided for mounting signs of the type to be supported by the structure. For better visibility, they shall be adjustable to permit mounting the sign faces at any angle between a truly vertical position and three degree from vertical. This angle shall be obtained by rotating the front lower edge of the sign forward. All brackets shall be of a length equal to the heights of the signs being supported.

**16.50.6.6** Before erecting support structures, the bottom of each base plate shall be protected with an approved material which will adequately prevent any harmful reaction between the plate and the concrete.

**16.50.6.7** The end supports shall be plumbed by the use of levelling nuts and the space between the foundation and base plate shall be completely filled with an anti-shrink grout.

**16.50.6.8** Anchor bolts for sign supports shall be set to proper locations and elevation with templates and carefully checked after construction of the sign foundation and before the concrete has set.

**16.50.6.9** All nuts on aluminium trusses, except those used on the flanges, shall be tightened only until they are snug. This includes the nuts on the anchor bolts. A thread lubricant shall be used with each aluminium nut.

**16.50.6.10** All nuts on galvanized steel trusses, with the exception of high strength bolt connections, shall be tightened only to a snug condition.

**16.50.6.11** Field welding shall not be permitted.



**16.50.6.12** After installation of signs is completed; the sign shall be inspected by the Engineer. If specular reflection is apparent on any sign, its positioning shall be adjusted by the Contractor to eliminate or minimize this condition.

#### **16.50.7 Measurement**

These shall be measured in sq.meter upto two place of decimal.

#### **16.50.8 Rate**

The rate includes the cost of materials, labour and equipments involved in all the operations described above.

### **16.51 ROAD MARKINGS STRIPS**

The colour width and layout of road markings shall be in accordance with the Code of Practice for Road Markings with paints, IRC : 35, and as specified in the drawings or as directed by the Engineer-in-Charge.

#### **16.51.1 Materials**

Road markings shall be of ordinary road marking paint (retro-reflective), hot applied thermoplastic compound as specified in the item.

#### **16.51.2 Hot Applied Thermoplastic Road Marking**

##### **General**

- (i) The thermoplastic material shall be homogenously composed of aggregate, pigment, resins and glass reflectorizing beads.
- (ii) The thermoplastic compound shall be screeded/extruded on to the pavement surface in a molten state by suitable machine capable of controlled preparation and laying with surface application of glass beads at a specific rate. Upon cooling to ambient pavement temperature, it shall produce an adherent pavement marking of specified thickness and width and capable of resisting deformation by traffic.
- (iii) The thermoplastic material shall conform to ASTM D36/BS-3262-(Part I).
- (iv) The material shall meet the requirements of these specifications for a period of one year. The thermoplastic material must also melt uniformly with no evidence of skins or unmelted particles for the one year storage period. Any material not meeting the above requirements shall be replaced by the manufacturer/supplier/Contractor.
- (v) **Marking** : Each container of the thermoplastic material shall be clearly and indelibly marked with the following information:
  1. The name, trade mark or other means of identification of manufacturer.
  2. Batch number
  3. Date of manufacture
  4. Colour (White or yellow)
  5. Maximum application temperature and maximum safe heating temperature.
- (vi) **Sampling and Testing** : The thermoplastic material shall be sampled and tested in accordance with the appropriate ASTM/BS method. The Contractor shall furnish to the Engineer-in-Charge a copy of certified test reports from the manufacturers of the thermoplastic material showing results of all tests specified herein and shall certify that the material meets all requirements of this Specification.



### 16.51.3 Preparation

- (i) The material shall be melted in accordance with the manufacturer's instructions in a heater fitted with a mechanical stirrer to give a smooth consistency to the thermoplastic material to avoid local overheating. The temperature of the mass shall be within the range specified by the manufacturer, and shall on no account be allowed to exceed the maximum temperature stated by the manufacturer. The molten material should be used as expeditiously as possible and for thermoplastic material which has natural binders or is otherwise sensitive to prolonged heating, the material shall not be maintained in a molten condition for more than 4 hours.
- (ii) After transfer to the laying equipment, the material shall be maintained within the temperature range specified by the manufacturer for achieving the desired consistency for laying.

### 6.51.4 Properties of Finished Road Marking

- (a) The stripe shall not be slippery when wet.
- (b) The marking shall not lift from the pavement in freezing weather.
- (c) After application and proper drying, the stripe shall show no appreciable deformation or discolouration under traffic and under road temperatures upto 60°C.
- (e) The marking shall not deteriorate by contact with sodium chloride, calcium chloride or oil drippings from traffic. The stripe or marking shall maintain its original dimensions and position. Cold ductility of the material shall be such as to permit normal movement with the road surface without chopping or cracking.
- (f) The colour of yellow marking shall conform to IS Colour No. 356 as given in IS 164.

### 16.51.5 Application

Marking shall be done by fully /semi automatic paint applicator machine fitted with profile shoe, glass beads dispenser, propane tank heater and profile shoe heater, driven by experienced operator as specified in item. For locations where painting cannot be done by machine, approved manual methods shall be used with prior approval of the Engineer-in-charge. The Contractor shall maintain control over traffic while painting operations are in progress so as to cause minimum inconvenience to traffic compatible with protecting the workmen.

The thermoplastic material shall be applied hot either by screeding or extrusion process. After transfer to the laying apparatus, the material shall be laid at a temperature within the range specified by the manufacturer or otherwise directed by the Engineer-in-Charge for the particular method of laying being used. The paint shall be applied using a screed or extrusion machine.

The pavement temperature shall not be less than 10°C during application. All surfaces to be marked shall be thoroughly cleaned of all dust, dirt, grease, oil and all other foreign matter before application of the paint.

Thermoplastic paint shall be applied in intermittent or continuous lines of uniform thickness of at least 2.5 mm unless specified otherwise. Where arrows or letters are to be provided, thermoplastic compound may be hand-sprayed.

The minimum thickness specified is exclusive of surface applied glass beads.

The finished lines shall be free from ruggedness on sides and ends and be parallel to the general alignment of the carriageway. The upper surface of the lines shall be level, uniform and free from streaks.

#### **16.51.6 Measurements for Payment**

The painted markings shall be measured in sq. metres of actual area marked (excluding the gaps, if any) correct upto the two places of decimal.

**16.51.7** The rate include the cost of all materials, labour and equipments required in all the above operations.

#### **16.52 KERB CHANNEL OF CEMENT CONCRETE**

**Base :** The base of the channel to be of the 75 mm compacted thick dry brick ballast 40 mm nominal size well rammed and consolidated and grouted with fine sand.

Kerb channel shall be provided in cement concrete of specified grade. These shall be cast in-situ of specified size as given in the item. Top surface of channel to be finished smooth.

**Measurements :** Cement concrete channel shall be measured in metre of length of the completed channel correct upto two places of decimal.

**Rate :** The rate includes the cost of all the materials, labours and tools required in all the operations described above.

#### **16.53 75 MM THICK COMPACTED BED OF DRY BRICK BALLAST**

##### **16.53.1 Collection of Material**

Before the start of work brick aggregate 40 mm nominal size unless specified otherwise, shall be stacked for the entire work and record measurements done as per para 16.4.

##### **16.53.2 Preparation of Sub Grade**

The formation for a width equal to that of the area shall be cut to the depth below the proposed finish level, equal to the thickness of the course of brick aggregate (due allowance being made for consolidation) and dress off in level to the finished profile. In case of made up soil, copious water shall be poured so that earth settles down as much as possible and the same rolled up with 3 tonnes or light power roller, as directed by the Engineer-in-Charge.

##### **16.53.3 Laying and Packing Brick Aggregate**

Brick aggregate shall be racked off the stack with the racks so as to leave behind mud and dust. It shall be spread evenly over the prepared surface to the required depth with a finishing material to avoid segregation. Brick aggregate shall be carefully laid and packed, bigger size being placed at the bottom to 7.5 cm. depth unless specified otherwise. After that the area shall be grouted with fine sand.

##### **16.53.4 Consolidation**

The bricks aggregate shall be consolidated by dry rolling with 3 tonne or light weight power roller as directed by the Engineer-in-Charge.

##### **16.53.5 Measurement**

The measurement of the finished work shall be taken in sqm. correct to two places of decimal. Length and breadth shall be measured in metre correct to a centimeter.

##### **16.53.6 Rate**

Rate includes the cost of all the materials, labour and equipment required in all the operations as described above.

## **16.54 POST DELINEATORS**

**16.54.1** The role of delineators is to provide visual assistance to drivers about alignment of the road ahead, especially at night. Delineators are particularly effective in the case of complex locations involving changes in horizontal / vertical geometry and during severe weather conditions such as heavy rain, fog or snow. Normally reflectors are used on the delineators for better night time visibility. Road delineators may have a circular, rectangular or triangular cross-section, however the side facing the traffic should not be less than 10 cm wide.

In board sense, Delineators stands for any device or treatment whose aim is to outline the road way.

### **16.54.2 Material :**

The design, materials to be used and the location of the road delineators shall conform to recommended practice for road delineators, IRC:79, and to relevant drawings and as directed by the Engineer-in-charge.

The delineators are to be made of Acrylonitrile Butadiene Styrene (ABS) body fitted with 2 No. 100 mm dia of highly reflective reflectors are mounted on M.S. pipe of 65 mm dia or of size specified otherwise, duly powder coated of minimum 40 microns thickness anti-rust and anti-theft, installed as per direction of Engineer-in-charge. Road delineators may have a circular, rectangular or triangular cross-section, however the side facing the traffic should not be less than 10 cm wide.

### **16.54.3 Dimensions :**

Height of the delineator should be not less than 800 mm above ground. Width not less than 100 mm. Not more than 300 mm below the ground while being installed.

### **16.54.4 Placement and spacing :**

As a general rule, delineator posts should be erected at the edge of the usable shoulders, and in the case of kerbed sections at a distance of 0.6 to 1.5 m from the kerb face. On hill roads they may be placed either on the parapet or at the edge of the shoulders.

The delineator should be so positioned that the reflectorised face is perpendicular to the direction of travel.

### **Warranty :**

The contractor shall obtain a two years warranty for satisfactory performance including stipulated retro-reflectance of the retro-reflective sheeting and submit the same to the Engineer-in-charge.

### **16.54.5 Measurement**

The measurement shall be made in numbers of delineators fixed at site.

### **16.54.6 Rate**

The rate include the cost of all the material, labour and equipments required in all the operations described above.

## **16.55 EXCAVATING HOLES UPTO 0.10 CUM**

The specifications of sub head earth work of CPWD specifications 2019 Vol-I to be followed for this item.

## **16.56 FACTORY MADE RCC PAVEMENT SLAB**

Precast RCC slab casted with the cement concrete of M-30 or specified otherwise grade of size specified in item made of approved brand and manufacturer to be used.

Specification of cement concrete base, bed cement mortar and RCC to be of the sub head cement concrete, mortar and RCC of the CPWD specification- 2019 Vol- I to be followed.

## **16.57 FACTORY MADE CEMENT CONCRETE INTERLOCKING PAVER BLOCK**

### **16.57.1 Base**

Interlocking paver block to be fixed on the bed 50 mm or specified otherwise thick of coarse sand of approved specification and filling the joints with the sand of approved type and quality or as specified and as directed by Engineer-in-charge.

### **16.57.2 Interlocking Paver Block**

Factory made precast paver block of M-30 or otherwise specified grade to be used. Paver blocks to be of approved brand and manufacturer and of approved quality. Minimum strength as prescribed by manufacturer and as per direction of Engineer-in-Charge for the grade specified to be tested as per method mentioned in specification of subhead cement concrete of CPWD Specification 2019 Vol. I.

### **16.57.3 Measurement & Rates**

Area provided with paver block to be measured in sqm. correct upto two places of decimal. The rate include the cost of the material, labour, tools etc. required in all the operations described above.

## **16.58 KERB STONE (PRECAST)**

### **16.58.1 Laying**

**16.58.1.1** Trenches shall first be made along the edge of the wearing course of the road to receive the kerb stones of cement concrete of specified grade. The bed of the trenches shall be compacted manually with steel rammers to a firm and even surface and then the stones shall be set in cement mortar of specified proportion.

**16.58.1.2** The kerb stones with top 20 cm. wide shall be laid with their length running parallel to the road edge, true in line and gradient at a distance of 30 cm. from the road edge to allow for the channel and shall project about 12.5 cm. above the latter. The channel stones with top 30 cm. wide shall be laid in position in chamber with finished road surface and with sufficient slope towards the road gully chamber. The joints of kerb and channel stones shall be staggered and shall be not more than 10 mm. Wherever specified all joints shall be filled with mortar 1:3 (1 cement : 3 coarse sand) and pointed with mortar 1:2 (1 cement: 2 fine sand) which shall be cured for 7 days.

**16.58.1.3** The necessary drainage openings of specified sizes shall be made through the kerb as per drawings or as directed by the Engineer-in-Charge for connecting to storm water drains.

### **16.58.2 Finishing**

Berms and road edges shall be restored and all surplus earth including rubbish etc. disposed off as directed by the Engineer-in-charge. Nothing extra shall be paid for this.

### **16.58.3 Measurements**

It shall be measured in cubic meters with Length of the finished work (for specified width and height of stone) shall be measured in running metre along the edge of the road correct to a cm.

### **16.58.4 Rate**

The rate shall include the cost of all the materials and labour involved in all the operations described above.

## **16.59 G.I. CHAIN LINK FABRIC FENCING**

### **16.59.1 Material**

G.I. Chain link fabric fencing of required width in mesh size 50 x 50 or 25 x 25 mm or specified otherwise of approved brand and made of specified dia GI wire PVC coated of specified thickness / or not as specified in item of required colour or shade to be used.

**16.59.1.1 Fixing :** GI chain link shall be stretched and fixed in specified width, strengthening with 2 mm dia wire or nuts bolts & washers as required to be done complete as per the direction of Engineer-in-Charge.

**16.59.1.2 Measurements :** The length and width shall be measured correct to a cm. The area shall be calculated in square metre, correct to two places of decimal.

**16.59.2** The rate shall include the cost of material and labour involved in all the operations described as above.

### **16.60 SUPPLYING AND STACKING OF HARD STONE (FOR STONE PITCHING)**

Hard stone hammer dressed having no side less than 15 cm. with minimum depth of 20 cm. of the specification as mentioned in subhead - stone work of CPWD Specification- 2019 Vol. I to be used.

Specification for supplying, stacking and measurement to be same as for item no. 16.3.

### **16.61 VACUUM DEWATERED CEMENT CONCRETE PAVEMENT**

**16.61.1** Cement concrete to be compacted by screed board vibrator of the type approved by Engineer-in-Charge and by vacuum dewatering process complete as per directions of Engineer-in-charge.

#### **16.61.2 Measurements**

It shall be measured in cubic metres correct to two place of decimal.

#### **16.61.3 Rate**

The rate shall include the cost of material, labour and machinery involved in all the operations described above.

### **16.62. GRANULAR SUB-BASE**

#### **16.62.1. Scope**

This work shall consist of laying and compacting well-graded material on prepared subgrade in accordance with the requirements of these Specifications. The material shall be laid in one or more layers as sub-base or lower sub-base and upper sub-base (termed as sub-base hereinafter) as necessary according to lines, grades and cross-sections shown on the drawings or as directed by the Engineer-in-charge.

#### **16.62.2. Materials**

**16.62.2.1.** The material to be used for the work shall be natural sand, crushed gravel, crushed stone, crushed slag or combination thereof depending upon the grading required. Use of materials like brick metal, Kankar and crushed concrete shall be permitted in the lower sub-base. The material shall be free from organic or other deleterious constituents and shall conform to the grading given in Table 16.44 and physical requirement given in Table 16.45 Gradings III and IV shall preferably be used in lower sub-base. Grading V and VI shall be used as a sub-base-cum-drainage layer. The grading to be adopted for a project shall be as specified in the Contract. Where the sub-base is laid in two layers as upper sub-base and lower sub-base, the thickness of each layer shall not be less than 150 mm.

**16.62.2.2** If the water absorption of the aggregate determined as per IS : 2386 (Part 3); if this value is greater than 2 per cent, the aggregate shall be tested for Wet Aggregate Impact Value (AIV) (IS: 5640). Soft aggregates like Kankar, Brick ballast and laterite shall also be tested for Wet AIV (IS: 5640).

**TABLE No. 16.44  
GRADING FOR GRANULAR SUB-BASE MATERIALS**

| IS Sieve Designation | Percent by Weight Passing the IS Sieve |            |             |            |           |            |
|----------------------|--|------------|-------------|------------|-----------|------------|
|                      | Grading I                              | Grading II | Grading III | Grading IV | Grading V | Grading VI |
| 75.0 mm              | 100                                    | --         | --          | --         | 100       | --         |
| 53.0 mm              | 80-100                                 | 100        | 100         | 100        | 80-100    | 100        |
| 26.5 mm              | 55-90                                  | 70-100     | 55-75       | 50-80      | 55-90     | 75-100     |
| 9.50 mm              | 35-65                                  | 50-80      | --          | --         | 35-65     | 55-75      |
| 4.75 mm              | 25-55                                  | 40-65      | 10-30       | 15-35      | 25-50     | 30-55      |
| 2.36 mm              | 20-40                                  | 30-50      | --          | --         | 10-20     | 10-25      |
| 0.85 mm              | --                                     | --         | --          | --         | 2-10      | --         |
| 0.425 mm             | 10-15                                  | 10-15      | --          | --         | 0-5       | 0-8        |
| 0.075 mm             | <5                                     | <5         | <5          | <5         | --        | 0-3        |

**TABLE No. 16.45  
PHYSICAL REQUIREMENTS FOR MATERIALS FOR GRANULAR SUB-BASE**

|  |                             |   |
|--|-----------------------------|---|
| Aggregate Impact Value (AIV)               | IS:2386 (Part 4) or IS:5640 | 40 Maximum  |
| Liquid Limit                               | IS:2720 (Part 5)            | Maximum 25  |
| Plasticity Index                           | IS:2720 (Part 5)            | Maximum 6   |
| CBR at 98% dry density (at IS:2720-Part 8) | IS:2720 (Part 5)            | Minimum 30 unless otherwise specified in the Contract |

### 16.62.3 Construction Operations

#### 16.62.3.1. Preparation of Sub-Grade:

The surface of the sub grade to receive the Granular Sub-base shall be prepared to the specified lines and crossfall (Camber) as necessary and made free of dust and other extraneous materials. Any ruts or soft yielding places shall be corrected in an approved manner and rolled with 80 – 100 kN smooth wheeled roller until firm surface is obtained if necessary by sprinkling water. Weak places shall be strengthened, corrugations removed and depressions and pot holes made good with suitable materials, before spreading the aggregate for GSB.

Where the existing surface over which the sub base of GSB is to be laid is black topped, to ensure effective internal drainage, furrows 50 mm x 50 mm (depth of furrows increased to reach bottom of bituminous layer where necessary) at one metre intervals shall be cut in the existing bituminous surface at 45 degrees to the central line of the carriageway at one metre intervals in the existing road before the GSB is laid.

#### 16.62.3.2 Spreading and compacting:

The sub-base material of grading specified in the Contract and water shall be mixed mechanically by a suitable mixer equipped with provision for controlled addition of water and mechanical mixing. So as to ensure homogenous and uniform mix. The required water content shall be determined in accordance with IS:2720 (Part 8). The mix shall be spread on the prepared sub-grade with the help of a motor grader of adequate capacity, its blade having hydraulic controls suitable for initial adjustment and for maintaining the required slope and grade during the operation, or other means as approved by the Engineer-in-charge.

Moisture content of the mix shall be checked in accordance with IS:2720 (Part 2) and suitably adjusted so that, at the time of compaction, it is from 1 to 2 per cent below the optimum moisture content (OMC).



Immediately after spreading the mix, rolling shall be done by an approved roller. If the thickness of the compacted layer does not exceed 100 mm, a smooth wheeled roller of 80 to 100 kN weight may be used. For a compacted single layer upto 200 mm the compaction shall be done with the help of a vibratory roller of minimum 80 to 100 kN static weight capable of achieving the required compaction. Rolling shall commence at the lower edge and proceed towards the upper edge longitudinally for portions having unidirectional crossfall or on super elevation. For carriageway having crossfall on both sides, rolling shall commence at the edges and progress towards the crown.

Each pass of the roller shall uniformly overlap not less than one third of the track made in the preceding pass. During rolling, the grade and crossfall (camber) shall be checked and any high spots or depressions, which become apparent, corrected by removing or adding fresh material. The speed of the roller shall not exceed 5 km per hour.

Rolling shall be continued till the density achieved is at least 98 percent of the maximum dry density for the material determined as per IS : 2720 (Part 8). The surface of any layer of material on completion of compaction shall be well closed, free from movement under compaction equipment and from compaction planes, ridges, cracks or loose material. All loose, segregated or otherwise defective areas shall be made good to the full thickness of layer and re-compacted.

#### **16.62.4 Measurements**

Granular sub-base shall be measured as finished work in position in cubic metres. The length and breadth shall be measured to the nearest centimetre. The depth of consolidated layer shall be computed to nearest half centimetre by taking average of depths at the centre and at 30 cm from the left and right edges at a cross section taken at 100 metre interval or less as decided by the Engineer-in-Charge by making small pits. The consolidated cubical contents shall be calculated in cubic metres correct to two places of decimal. The protection of edges of granular sub-base extended over the full formation as shown in the drawing shall be considered incidental to the work of providing granular sub-base and as such no extra payment shall be made for the same.

#### **16.62.5. Rate**

The Contract unit rate for granular sub-base shall be payment in full for carrying out the required operations including all labour, tools, equipments, machinery and incidentals to complete the work to the specifications as described above.

### **16.63. WET MIX MACADAM (WMM) SUB-BASE/BASE**

#### **16.63.1 Scope**

This work shall consist of laying and compacting clean, crushed, graded aggregate and granular material, premixed with water, to a dense mass on a prepared subgrade/sub-base/base or existing pavement as the case may be in accordance with the requirements of these Specifications. The material shall be laid in one or more layers as necessary to lines, grades and cross-sections shown on the approved drawings or as directed by the Engineer-in-charge.

The thickness of a single compacted Wet Mix Macadam layer shall not be less than 75 mm. When vibrating or other approved types of compacting equipment are used, the compacted depth of a single layer of the sub-base course may be increased to 200 mm upon approval of the Engineer-in-charge.

#### **16.63.2. Materials**

##### **16.63.2.1. Aggregates**

##### **16.63.2.1.1. Physical requirements**

Coarse aggregates shall be crushed stone. If crushed gravel/shingle is used, not less than 90 per cent by weight of the gravel/shingle pieces retained on 4.75 mm sieve shall have at least two fractured faces. The aggregates shall conform to the physical requirements set forth in Table 16.46 below.

If the water absorption value of the coarse aggregate is greater than 2 per cent, the soundness test shall be carried out on the material delivered to site as per IS:2386(Part-5).



**TABLE 16.46**  
**PHYSICAL REQUIREMENTS OF COARSE AGGREGATES FOR SUB-BASE/BASE COURSES**

|    | <b>Test</b>  | <b>Test Method</b>                              | <b>Requirement</b>                        |
|----|--|---|---|
| 1. | Los Angeles Abrasion value<br>or<br>Aggregate impact value | IS:2386 (Part-4)                                | 40 per cent (Max.)                        |
| 2. | Combined Flakiness and Elongation indices (Total)          | IS:2386 (Part-4) or IS:5640<br>IS:2386 (Part-1) | 30 per cent (Max.)<br>35 per cent (Max.)* |

\* To determine this combined proportion, the flaky stone from a representative sample should first be separated out. Flakiness index is weight of flaky stone metal divided by weight of stone sample. Only the elongated particles be separated out from the remaining (non-flaky) stone metal. Elongation index is weight of elongated particles divided by total non-flaky particles. The value of flakiness index and elongation index so found are added up.

**16.63.2.1.2. Grading requirements :**

The aggregates shall conform to the grading given in Table 16.47 below.

**TABLE 16.47**  
**GRADING REQUIREMENTS OF AGGREGATES FOR WET MIX MACADAM**

| <b>IS Sieve Designation</b> | <b>Per cent by weight passing the IS sieve</b> |
|-----------------------------|--|
| 53.00 mm                    | 100  |
| 45.00 mm                    | 95-100   |
| 26.50 mm                    | ---  |
| 22.40 mm                    | 60-80  |
| 11.20 mm                    | 40-60  |
| 4.75 mm                     | 25-40  |
| 2.36 mm                     | 15-30  |
| 600.00 micron               | 8-22   |
| 75.00 micron                | 0-5  |

Materials finer than 425 micron shall have Plasticity Index (PI) not exceeding 6.

The final gradation approved within these limits shall be well graded from coarse to fine and shall not vary from the low limit on one sieve to the high limit on the adjacent sieve or vice versa.

**16.63.3. Construction Operations**

**16.63.3.1. Preparation of base :**

The surface of the sub grade / sub base / base to receive the Wet Mix Macadam shall be prepared to the specified lines and crossfall (Camber) as necessary and made free of dust and other extraneous materials. Any ruts or soft yielding places shall be corrected in an approved manner and rolled with 80-100 kN smooth wheeled roller until firm surface is obtained if necessary by sprinkling water. Weak places shall be strengthened, corrugations removed and depressions and pot holes made good with suitable materials, before spreading the aggregate for WMM.

Where the existing surface over which the sub base of WMM is to be laid is black topped, to ensure effective internal drainage, furrows 50 mm x 50 mm (depth of furrows increased to reach bottom of bituminous layer where necessary) at one metre intervals shall be cut in the existing bituminous surface at 45 degrees to the central line of the carriageway at one metre intervals in the existing road before the WMM is laid.

#### **16.63.3.2. Provision of lateral confinement of aggregates:**

While constructing wet mix macadam, arrangement shall be made for the lateral confinement of wet mix. This shall be done by laying materials in adjoining shoulders along with that of wet mix macadam layer.

#### **16.63.3.3. Preparation of mix:**

Wet Mix Macadam shall be prepared in an approved mixing plant of suitable capacity having provision for controlled, addition of water and forced/positive mixing arrangement like pugmill or pan type mixer of concrete batching plant. For small quantity of wet mix work, the Engineer may permit the mixing to be done in concrete mixers.

Optimum moisture for mixing shall be determined in accordance with IS:2720 (Part-8) after replacing the aggregate fraction retained on 22.4 mm sieve with material of 4.75 mm to 22.4 mm size. While adding water, due allowance should be made for evaporation losses. However, at the time of compaction, water in the wet mix should not vary from the optimum value by more than agreed limits. The mixed material should be uniformly wet and no segregation should be permitted.

#### **16.63.3.4. Spreading of mix :**

Immediately after mixing, the aggregates shall be spread uniformly and evenly upon the prepared subgrade/sub- base/base in required quantities. In no case should these be dumped in heaps directly on the area where these are to be laid nor shall their hauling over a partly completed stretch be permitted.

The mix may be spread either by a paver finisher.

The paver finisher shall be self-propelled of adequate capacity with the following features:

- (i) Loading hoppers and suitable distribution system. So as to provide a smooth uninterrupted material flow for different layer thickness from the tipper to the screed.
- (ii) Hydraulically operated telescopic screed for paving width upto 8.5 metre and fixed screed beyond this. The screed shall have tamping and vibrating arrangement for initial compaction of the layer.
- (iii) Automatic leveling control system with electronic sensing device to maintain mat thickness and cross slope of mat during laying procedure. In exceptional cases where it is not possible for the paver to be utilized mechanical means like motor grader may be used with the prior approval of the Engineer-in-charge. The motor grader shall be capable of spreading the material uniformly all over the surface.

The surface of the aggregate shall be carefully checked with templates and all high or low spots remedied by removing or adding aggregate may be required. The layer may be tested by depth blocks during construction. No segregation of larger and fine panicles should be allowed. The aggregates as spread should be of uniform gradation with no pockets of fine materials.

The Engineer-in-charge may permit manual mixing and / or laying of Wet Mix Macadam, where small quantity of WMM is to be executed. Manual mixing / laying in inaccessible / remote locations and in situations where use of machinery is not feasible can also be permitted. Were manual mixing / laying is intended to be used, the same shall be done with the approval of the Engineer-in-charge.

#### **16.63.3.5. Compaction:**

After the mix has been laid to the required thickness, grade and crossfall/camber the same shall be uniformly compacted, to the full depth with suitable roller. If the thickness of single compacted layer does not exceed 100 mm, a smooth wheel roller of 80 to 100 kN weight may be used. For a compacted single layer upto 200 mm, the compaction shall be done with the help of vibratory roller

of minimum static weight of 80 to 100 kN with an arrangement for adjusting the frequency and amplitude. An appropriate frequency and amplitude may be selected. The speed of the roller shall not exceed 5 km/h.

In portions having unidirectional cross fall/superelevation, rolling shall commence from the lower edge and progress gradually towards the upper edge. Thereafter, roller should progress parallel to the centre line of the road, uniformly over-lapping each preceding track by at least one-third width until the entire surface has been rolled. Alternate trips of the roller shall be terminated in stops at least 1 m away from any preceding stop.

In portions in camber, rolling should begin at the edge with the roller running forward and backward until the edges have been firmly compacted. The roller shall then progress gradually towards the centre parallel to the centre line of the road uniformly overlapping each of the preceding track by at least one-third width until the entire surface has been rolled.

Any displacement occurring as a result of reversing of the direction of a roller or from any other cause shall be corrected at once as specified and/or removed and made good.

Along forms, kerbs, walls or other places not accessible to the roller, the mixture shall be thoroughly compacted with mechanical tampers or a plate compactor. Skin patching of an area without scarifying the surface to permit proper bonding of the added material shall not be permitted.

Rolling should not be done when the subgrade is soft or yielding or when it causes a wave-like motion in the sub-base/base course or subgrade. If irregularities develop during rolling which exceed 12 mm when tested with a 3 metre straight edge, the surface should be loosened and premixed material added or removed as required before rolling again so as to achieve a uniform surface conforming to the desired grade and crossfall. In no case should the use of unmixed material be permitted to make up the depressions.

Rolling shall be continued till the density achieved is at least 98 per cent of the maximum dry density for the material as determined by the method outlined in IS: 2720 (Part-8)

After completion, the surface of any finished layer shall be well-closed, free from movement under compaction equipment or any compaction planes, ridges, cracks and loose material. All loose, segregated or otherwise defective areas shall be made good to the full thickness of the layer and recompacted.

**16.63.3.6. Setting and drying:** After final compaction of wet mix macadam course, the road shall be allowed to dry for 24 hours.

#### **16.63.4. Opening to Traffic**

No vehicular traffic of any kind should be allowed on the finished wet mix macadam surface till it has dried and the wearing course laid.

#### **16.63.5. Surface Evenness**

All work perform shall confirm to the lines, grades, cross sections and dimensions shown on the drawings or as directed by the Engineer-in-charge, subject to the permitted tolerances described herein after.

##### **16.63.5.1 Horizontal Alignment**

Horizontal alignments shall be reckoned with respect to the centre line of the carriageway as shown on the drawings. The edges of the carriage way as constructed shall be correct within a tolerance of  $\pm 10$  mm there from. The corresponding tolerance for edges of the roadway and lower layers of pavement shall be  $\pm 25$  mm.

### 16.63.5.2 Surface Levels

The levels of the Sub-base / base course as constructed, shall not vary from those calculated with reference to the longitudinal and cross-profile of the road shown on the drawings or as directed by the Engineer-in-charge beyond the tolerances mentioned as below:

#### TOLERANCES IN SURFACE LEVELS OF WMM

|                                     |         |
|-------------------------------------|---------|
| Sub-base                            |         |
| (a) Flexible pavement               | ± 10 mm |
| (b) Concrete pavement               | ± 06 mm |
| Base course flexible pavement       |         |
| (a) Bituminous Base / Binder Course | ± 06 mm |
| (b) Granular                        |         |
| (i) Machine laid                    | ± 10 mm |
| (ii) Manually laid                  | ± 15 mm |

For checking compliance with the above requirement for sub-base / base courses, measurements of the surface levels shall be taken on a grid of points placed at 6.25 m longitudinally and 3.5 m transversely.

The longitudinal profile shall be checked with a 3 metre long straight edge / moving straight-edge as desired by the Engineer-in-charge at the middle of each traffic lane along a line parallel to the centre line of the road.

### 16.63.6. Measurements

Wet Mix Macadam shall be measured as finished work in position in cubic metres. The length and breadth shall be measured to the nearest centimetre. The depth of consolidated layer shall be computed to nearest half centimetre by taking average of depths at the centre and at 30 cm from the left and right edges at a cross section taken at 100 metre interval or less as decided by the Engineer-in-Charge by making small pits. The consolidated cubical contents shall be calculated in cubic metres correct to two places of decimal.

### 16.63.7. Rates

The contract unit rate for Wet Mix Macadam shall be payment in full for carrying out the required operations including all labour, tools, equipments machinery and incidentals to complete the work to the specification as described above.

## 16.64 REFLECTIVE PAVEMENT MARKERS (RPM) OR ROAD STUDS

### 16.64.1 Scope

The work shall cover the providing and fixing of reflective pavement marker (RPM) or road stud, a device which is bonded to or anchored within the road surface, for lane marking and delineation for night-time visibility, as specified in the Contract.

### 16.64.2 Material

**16.64.2.1** Plastic body of RPM/road stud shall be moulded from ASA (Acrylic Styrene Acrylonitrile) or HIPS (Hi-impact Polystyrene) or Acrylonitrile Butadiene Styrene (ABS) or any other suitable material approved by the Engineer. The markers shall support a load of 13.635 kg tested in accordance with ASTM D 4280.

**16.64.2.2** Reflective panels shall consist of number of lenses containing single or dual prismatic cubes capable of providing total internal reflection of the light entering the lens face. Lenses shall be moulded of methacrylate conforming to ASTM D 786 or equivalent.

### 16.64.3 Design

The slope or retro-reflecting surface shall preferably be  $35 \pm 5^\circ$  to base and the area of each retro-reflecting surface shall not be less than 13.0 sq.cm.

### 16.64.4 Optical Performance

#### 16.64.4.1 Unidirectional and Bi-directional Studs.

Each reflector or combination of reflectors on each face of the stud shall have a Coefficient of Luminous Intensity (C.I.L.), as specified in **Table 16.48**

**TABLE NO 16.48**  
**Minimum C.I.L. values for Road Studs**

| Entrance Angle | Observation Angle | C.I.L. in mcd/lx |       |     |
|----------------|-------------------|------------------|-------|-----|
|                |                   | White            | Amber | Red |
| 0° U 5° L&R    | 0.3°              | 220              | 110   | 44  |
| 0° U 5° L&R    | 0.5°              | 120              | 60    | 24  |

### 16.64.5 Tests

**16.64.5.1** Co-efficient of luminance intensity can be measured by procedure described in ASTM E 809 "Practice for Measuring Photometric Characteristics" or as recommended in BS:873-Part 4 : 1973.

### 16.64.6 Fixing of Reflective Markers or Road Studs or Cats Eyes.

#### 16.64.6.1 Requirements

The enveloping profile of the head of the stud shall be smooth and the studs shall not present any sharp edges to traffic. The reflecting portions of the studs shall be free from crevices or ledges where dirt might accumulate. Marker height shall not be less than 10 mm and shall not exceed 20 mm, and its width shall not exceed 130 mm. The base of the marker shall be flat within 1.3 mm. If the bottom of the marker is configured, the outermost faces of the configurations shall not deviate more than 1.3 mm from a flat surface. All road studs shall be legibly marked with the name, trade mark or other means of identification of the manufacturer.

#### 16.64.6.2 Placement

The reflective marker shall be fixed to the road surface using the adhesives and the procedure recommended by the manufacturer. No nails shall be used to affix the marker so that they do not pose safety hazard on the roads. Regardless of the type of adhesive used, the markers shall not be fixed if the pavement is not surface dry and on new asphalt concrete surfacing until the surfacing has been opened to traffic for a period of not less than 14 hours. The portions of the highway surface, to which the marker is to be bonded by the adhesive, shall be free of dirt, curing compound, grease, oils, moisture, loose or unsound layers, paint and any other material which would adversely affect the bond of the adhesive.

The adhesive shall be placed uniformly on the cleaned pavement surface or on the bottom of the of the marker in a quantity sufficient to result in complete coverage of the area of contract of the marker with no voids present and with a slight excess after the marker has been lightly pressed in place. For epoxy installations, excess adhesive around the edge of the marker, excess adhesive on the pavement and adhesive on the exposed surfaces of the markers shall be immediately removed.

#### 16.64.6.3 Warranty and Durability

The contractor shall submit a two year warranty for satisfactory field performance including stipulated retro-reflectance of the reflecting panel, to the Engineer-in-charge. In addition, a two year warranty for satisfactory infield performance of the finished road marker shall also be given by the contractor who carries out the work of fixing of reflective road markers. In case the markers are displaced, damaged, get worn out or lose their reflectivity compared to stipulated standards, the contractor would be required to replace all such markers within 15 days of the intimation from the Engineer-in-charge, at his own cost.

### 16.64.7 Measurement

The measurement of reflective road markers or road studs shall be made in numbers supplied and fixed at site.

### 16.64.8 Rates

The rates include the cost of all the material, labour, tools and equipments required in all the operation described above.

## 16.65 PRIME COAT OVER GRANULAR BASE

### 16.65.1 Scope

This work shall consist of the application of a single coat of low viscosity liquid bituminous material to a porous granular surface preparatory to the superimposition of bituminous treatment or mix.

### 16.65.2 Materials

**16.65.2.1 Primer:-** The primer shall be cationic bitumen emulsion SS1 grade conforming to IS:8887 or medium curing cutback bitumen conforming to IS:217 or as specified in the contract.

**16.65.2.2** Quantity of SS1 grade bitumen emulsion for various types of granular surface shall be as given in Table 16.49 or as specified in the item of contract.

**Table 16.49**  
**Quantity of Bitumen Emulsion for various types of Granular Surfaces**

| Type of Surface                           | Rate of Spray (kg/sqm) |
|---|------------------------|
| WMM/WBM                                   | 0.7-1.0                |
| Stabilized soil bases/Crusher Run Macadam | 0.9-1.2                |

**16.65.2.3** Cutback for primer shall not be prepared at the site. Type and quantity of cutback bitumen for various types of granular surface shall be as given in Table 16.50.

**Table 16.50**  
**Type and Quantity of Cutback Bitumen for various types of Granular Surface**

| Type of Surface                           | Type of Cutback | Rate of Spray (kg/sq.m) |
|---|-----------------|-------------------------|
| WMM/WBM                                   | MC 30           | 0.6-0.9                 |
| Stabilized soil bases/Crusher Run Macadam | MC 70           | 0.9-1.2                 |

**16.65.2.4** The correct quantity of primer shall be decided by the Engineer-in-Charge and shall be such that it can be absorbed by the surface without causing run-off of excessive primer and to achieve desired penetration of about 8-10mm.

### 16.65.3 Construction

#### 16.65.3.1 Equipment

The primer shall be applied by a self propelled or towed bitumen pressure sprayer equipped for spraying the material uniformly at specified rates and temperatures. Hand spraying shall not be allowed except in small areas, inaccessible to the distributor, or in narrow strips where primer shall be sprayed with a pressure hand sprayer, or as directed by the Engineer-in-Charge.

### **16.65.3.2 Preparation of Road Surface**

The granular surface to be primed shall be swept clean by power brooms or mechanical sweepers and made free from dust. All loose material and other foreign material shall be removed completely. If soil/moorum binder has been used in the WBM surface, part of this should be brushed and removed to a depth of about 2 mm so as to achieve good penetration.

### **16.65.3.3 Application of Bituminous Primer**

After preparation of the road surface the primer shall be sprayed uniformly at the specified rate as per item of contract. The method for application of the primer will depend on the type of equipment to be used, size of nozzles, pressure at the spray bar and speed of forward movement. The contractor shall demonstrate at a spraying trial, that the equipment and method to be used is capable of producing a uniform spray, within the tolerances specified.

No heating or dilution of SS1 bitumen emulsion and shall be permitted at site. Temperature of cutback bitumen shall be high enough to permit the primer to be sprayed effectively through the jets of the spray and to cover the surface uniformly.

### **16.65.3.4 Curing of Primer and Opening to Traffic**

A primed surface shall be allowed to cure for at least 24 hours or such other higher period as is found to be necessary to allow all the moisture/volatiles to evaporate before any subsequent surface treatment or mix is laid. Any unabsorbed primer shall first be blotted with a light application of sand, using the minimum quantity possible. A primed surface shall not be opened to traffic other than that necessary to lay the next course.

### **16.65.4 Measurement for Payment**

Prime coat shall be measured in terms of surface area of application in square metres.

### **16.65.5 Rate**

The contract unit rate for prime coat shall be payment in full for carrying out the required operations i/c all equipments, labour and machinery as described above.



**APPENDIX A**

**BITUMEN REGISTER**  
(Clause 16.24 to 16.31, 16.32, 16.33)

Name of Work:  
Name of Contractor:

| <i>Receipts</i>        |                          |                          | <i>Issues</i>        |                                   |                    |                              |                             |                                  |
|------------------------|--------------------------|--------------------------|----------------------|-----------------------------------|--------------------|------------------------------|-----------------------------|----------------------------------|
| <i>Date of receipt</i> | <i>Quantity received</i> | <i>Progressive total</i> | <i>Date of issue</i> | <i>Quantity of Bitumen issued</i> | <i>Total issue</i> | <i>Daily Balance in hand</i> | <i>Contractor's initial</i> | <i>Junior Engineer's initial</i> |
| <i>1</i>               | <i>2</i>                 | <i>3</i>                 | <i>4</i>             | <i>5</i>                          | <i>6</i>           | <i>7</i>                     | <i>8</i>                    | <i>9</i>                         |

**Daily Comparison of Issues with Requirements**

| <i>Item of work for which issued</i> | <i>Approx. quantity of work done on each day</i> | <i>Theoretical requirement of bitumen for work done on each day</i> | <i>Assistant Executive Engineer/Assistant Engineer</i> | <i>Executive Engineer</i> |
|--------------------------------------|--|---|--|---------------------------|
| <b>10</b>                            | <b>11</b>  | <b>12</b>   | <b>13</b>  | <b>14</b>                 |

## DETERMINATION OF IN-SITU DENSITY OF ASPHALTIC CARPET OR BITUMINOUS MACADAM BY SAND POURING DEVICE

The metallic tray of the field density unit is kept on a level spot of the surface and a hole 10 cm in dia, is cut to the entire thickness of the carpet. All materials removed from the hole are carefully collected and weighed.

A known weight of dry standard sand, passing 710 micron I.S. Sieve and retained on 355 micron I.S. sieve, is taken in the sand pouring cylinder. The cylinder is kept directly over the hole and the shutter of the cylinder is released without any jerk and closed when the hole is filled with the sand. The quantity of the residual sand in the cylinder as well as the quantity filling the cone of the cylinder are weighed.

The in-situ density of the carpet is calculated as follows:-

$$\text{Density: } \frac{A, d}{W - (W_1 + W_2)} \text{ gm per cc}$$

- Where A = Weight of the materials removed from the carpet hole.  
 W = Initial weight of the sand taken in the cylinder.  
 W<sub>1</sub> = Weight of the sand filling the cone of cylinder.  
 d = Bulk density, gm per cc of the sand.  
 W<sub>2</sub> = Weight of sand remaining in the cylinder.

**LIST OF MINIMUM EQUIPMENT TO BE PROVIDED IN THE FIELD  
TESTING LABORATORY BY THE CONTRACTOR AT HIS OWN  
COST.**

**Concrete Section**

1. Sieve Analysis of stone ballast
  - (a) Sets of I.S. Sieves of sizes 63 mm, 45 mm, 22.4 mm, 11.2 mm, 5.60 mm. etc.
2. Sieve analysis of sand
  - (a) Sets of I.S. sieves of sizes 2.36 mm, 1.18 mm, 600 micron, 355 micron and 180 micron.
3. Silt content of sand
  - (a) Graduated glass cylinders 500 C.C. capacity.
4. Bulkage of sand
  - (a) Graduated glass cylinders 500 C.C. capacity.
5. Slump test.
  - (a) Slump cones.
  - (b) Slump rods 3/8" dia. 24" long bullet pointed.
  - (c) Steel plates 24" x 24"
  - (d) Steel scales.
6. For making beam specimens for flexural strength.
  - (a) Beam moulds.
  - (b) Tamping rods.
7. Testing flexural strength of concrete:-
  - (a) 100 ton capacity compressive strength testing i/c hand operated in two numbers with flexure test attachment.
8. Other miscellaneous items.
  - (a) Physical balance with set of weights.
  - (b) Pan balances.
  - (c) Spring balances.
  - (d) Glass measuring jar.
  - (e) Beakers.
  - (f) Towels, glass plates etc.

## GENERAL GUIDELINES ISSUED BY NDMC

## I. Roads/Foot Paths/and Storm Water Drains.

## A. RESIDENTIAL

| S.No | Specifications applicable prior to 26.9.79  | Specifications applicable after 27.9.79 (Modified)  | Remarks |
|------|---|---|---------|
| (1)  | (2)   | (3)   | (4)     |
| 1.   | 15 ft wide right of way service lanes: Metal width not less than 8'-0" 4-1/2" soling 4-1/2" metal two coats of bitumen painting                     | 4.577 tres (15ft) right of way service lane:<br>(i) Metalled width not less than 2.44 metres (8 ft.)<br>(ii) 0.1143 metres (4-1/2") thick stone aggregate sub-base course of W.B.M. as per IRC specifications.<br>(iii) 0.1143 metre (4-1/2") thick stone aggregate base-course W.B.M. as per IRC specifications.<br>(iv) 2 cm (3/4") thick pre-mix carpet with seal coat of premixed stone dust.<br>(v) 0.2286 metre (9") wide brick-on-edge edging on either side.<br>(vi) CC (M-150) channel 8 cm thick and 30 cm wide with gola of 8 cm radius laid over a bed layer of 8 cm thick 1:5:10 c.c. top surface finished with a floating coat of neat cement.<br>(vii)The space between brick edging and c.c. channel on both sides shall have brick on-edge flooring. |         |
| 2.   | 20 ft. wide right of way service lanes: Metalled width 10 ft. plus 9" brick-on-edge on either side. 4-1/2" soling 4-1/2" metal 3/4" bitumen carpet. | 6.098 metres (20 ft.) right of way service lane:<br>(i) Metalled width 3.48 metres (10 ft.)<br>(ii) 0.1143 metre (4-1/2") thick stone aggregate sub-base course of W.B.M. as per IRC specifications.<br>(iii) 0.1143 metre (4-1/2") thick stone aggregate base-course of W.B.M. as per IRC specifications.<br>(iv) 2 cm (3/4") thick pre-mix carpet with seal coat of premixed stone.<br>(v) 0.2286 metre (9") wide brick on edge edging on either side.C<br>(vi) C (M-150) channel 8cm thick and 30 cm wide with gola of 8 cm radius laid over a bed layer of 8 cm thick 1:5:10 cement concrete top surface finished with a floating coat of neat cement.<br>(vii)The space between brick edging & CC channel on both side brick on edge flooring.                   |         |
| 3.   | Roads with right of way 30 feet: 12 ft. Metalled width plus 9" thick edging on either side. 6" soling 6" metal (water                               | 9.14 metre (30 ft.) right way roads:<br>(i) metres (12 ft.) mettalled width with 0.2286 metre (9") wide brickon-edge-edging on either side  |         |

|    |   |  |   |
|----|---|--|---|
|    | bound 3" thick each layer)<br>3/4" carpet   | (ii) 0.1016 metre (4") thick stone aggregate base-course of W.B.M. as per IRC specifications.<br>(iii) 0.2032 metre (8") thick stone aggregate base-course of W.B.M. as per IRC specifications (to be laid in two layers).2<br>(iv) cm (3/4") thick pre mix carpet with seal coat of premixed stone dust.  |   |
| 4. | Service roads with right of way 40 ft. 18 ft. metalled width plus 9" thick edging on either side. 6" soling 7-1/2" metal (water bound 4-1/2" & 3" thick separately) 1" carpet.                            | 12.19 mtrs. (40 ft.) and less than 13.71 mtrs. (45 ft.) right of way roads:<br>(i) 7.32 m. (24 ft.) metalled width with 0.2286 m (9") wide brick-on-edge edging on either side.<br>(ii) 0.1524 m (6") stone aggregate sub-base course of W.B.M. as per IRC specifications.<br>(iii) 0.2032 m (7-1/2") stone aggregate base-course of W.B.M. as per IRC specifications (to be laid in two layers)<br>(iv) 2.5 cm (1") thick pre-mix carpet with seal coat of premixed stone dust.           | The change in metalled width is to adopt two lane width since 18 ft. width is not standard width. |
| 5. | Service roads with right of way 60 ft.<br>22 ft. metalled width plus 9" brickon-edge on both sides. 6" soling. 7-1/2" metal. 1-1/2" thick asphaltic concrete.   | 13.71 mtrs. (45 ft.) and less than 18.29 mtrs.(60 ft.) right of way road:<br>(i) 7.32 mtrs. (24 ft.) metalled with 0.2284 m (9") wide brick-on-edge on either side.<br>(ii) 0.1524 m (6") thick stone aggregate sub-base course of W.B.M. as per IRC specifications.<br>(iii) 0.2032 m (7 1/2") thick stone aggregate base-course of W.B.M. as per IRC specifications (to be laid in two layers).<br>(iv) 5 cm (2") thick Bituminous Macadam (B.M.) with seal coat of premixed stone dust. | The change in metalled width from 22 ft. to 24 ft. is to adopt standard two lane width.           |
| 6. | Roads with right of way above 60 ft. and upto 79 ft. 22 ft. metalled width 9" brick-on-edge on either side. 9" soling 7-1/2" metal (W.B.M. 4-1/2" & 3" thick separately). 1-1/2" thick asphaltic concrete | 18.29 mtrs. (60 ft.) and less than 24.38 mtrs. (80 ft.) right of way road<br>(i) 7.32 mtrs. (24 ft.) metalled with 0.2286 mtrs. (9") wide brick-on-edge edging.<br>(ii) 0.1524 m (6") thick stone aggregate sub-base of W.B.M. as per IRC specifications.<br>(iii) 0.2667 m (10-1/2") thick stone aggregate base-course of W.B.M. as per IRC specifications (to be laid in three layers).<br>(iv) 5 cm (2") thick Bituminous Macadam (BM) with seal coat of premixed stone dust.           | The change in metalled width from 22 ft. to 24 ft. is to adopt standard two lane width.           |
| 7. | Roads with right of way 80 ft. and above 9" soling.<br>Metalled width 24 ft. soling 9" 7- 1/2" metal. 1" carpet.  | 24.38 mtrs. (80 ft.) and above right of way road.<br>(i) 14.64 mtrs. (48 ft.) metalled width.  | The change in metal width is to adopt standard X section for 80 ft.                               |

|    |  |   |   |
|----|--|---|---|
|    |  | <p>(ii) 0.1524 m (6") thick stone aggregate sub-base course of W.B.M. as per IRC specifications.</p> <p>(iii) 0.2667 m (10-1/2") thick stone aggregate base-course of W.B.M. as per IRC specifications (to be laid in three layers).</p> <p>(iv) 5 cms. (2") thick Bituminous Macadam (BM) with seal coat of premixed stone dust.</p> <p>(v) 3.048 mtrs. (10 ft.) wide raised foot path on both sides of the carriageway as per specifications given hereinafter.</p> | <p>wide roads. Such roads normally carry heavy amount of traffic which needs a metalled width of 48 ft. for easy flow of traffic.</p> |
| 8. | Service lanes/ walkways having right of way less than 15 ft. Nil | <p>Service lanes/walkways having right of way less than 4.57 mtrs.(15 ft.)</p> <p>0.1143 mtrs. (4-1/2") thick cement concrete (M-150) over 0.1143 (4-1/2") dry brick ballast in complete width with c.c. (M-150) channel 8 cms. thick and 30 cm wide with gola of 8 cm radius laid over a bed layer of 8 cms. Thick 1:5:10 cement concrete top surface finished with floating coat of neat cement.</p>  |   |

**Notes :**

- (a) Roads with right of way 80 ft. and above passing through residential colony should have raised foot paths on either sides.
- (b) Where it is necessary for practical requirements to do the road work in two stages then it is advisable to do a coat of bitumen painting after leaving the first layer of water bound macadam.
- (c) Brick-edging 9" wide shall be provided beyond the metalled width of roads in item (2) to (5) above.
- (d) Brick pitched drains with adequate discharging capacity shall be provided on both sides of the road.
- (e) Where raised footpaths are not provided, berms shall be properly dressed to slope towards the side drains.

**Foot-Paths and Storm Water Drains for Roads in Residential and Industrial Areas**

| 1  | 2                     | 3   | 4 |
|----|-----------------------|---|---|
| 1. | 10 ft. wide foot-path | <p>3.048 mtrs. (10 ft.) wide foot-path</p> <p>(i) 0.076 m (3") thick dry brick ballast.</p> <p>(ii) 0.076 m (3") thick cement concrete M-150 pavement with or without chequered tiles embedded in cement concrete.</p> <p>(iii) Cement concrete (M-150) kerbstones of size 0.3048 m x 0.203 m (12" x 8")</p> <p>(iv) 0.2286 m x 0.3048 m brick toe wall on the other end of foot-path.</p> <p>(v) 0.3048 m (1 foot) wide channel with C.C. (M-150) 75 mm thick over 75 mm bed concrete 1:5:10 finished with a floating coat of neat cement.</p> <p><b>(vi)</b> NP class R.C.C. pipes 150 mm dia with collars jointed with cement mortar 1:2 (1 cement: 2 fine sand) for cross drainage with gully chambers of size 50 x 45 x 65 cms. with M.S. grating of size 500 x 450 mm</p> |   |

**Notes:**

1. Brick pitched drains with adequate designed discharge capacity shall be provided on both sides of the roads above 20 ft. right of way (For cross section of different R.O. roads, showing the carriage width, arrangement of footpaths, storm water drains, water supply mains, sewer lines and also of trees.
2. Where raised foot-paths are not provided, berms shall be properly dressed to slope toward the side drains.
3. The work shall be carried out as per prevailing CPWD/IRC specifications.
4. Crust thicknesses mentioned in the above specifications mean compact thicknesses.
5. Brick edging wherever mentioned in the above specifications shall be 0.1143 m (4-1/2") deep.
6. For any road having right of way other than mentioned in the specifications, the standard of the next higher R.O.W. will be applicable.

| S.No | Specifications applicable prior to 26.9.79 | Specification applicable after 27.9.79 (Modified)  |
|------|--|--|
| 1    | 2  | 3  |
| 1    | NIL .....                                  | (1) Roads/Service lanes having R/W less than 6.10 metres (20 ft.).<br>(i) Minimum length of the culvert shall be the entire width of R/W.  |
| 2    | NIL .....                                  | (2) Roads having R/W 6.10 metres (20 ft.).<br>(i) Minimum length of the culvert shall be 4.57 metres (15 ft.).                             |
| 3    | NIL .....                                  | (3) Roads having R/W 9.14 metres (30 ft.).<br>(i) Minimum length of the culvert shall be 6.10 metres (20 ft.).                             |
| 4    | NIL .....                                  | (4) Roads having R/W 12.19 m (40 ft.).<br>(i) Minimum length of the culvert shall be 9.14 metres (30 ft.).                                 |
| 5    | NIL .....                                  | (5) Roads having R/W 13.72 m (45 ft.).<br>(i) Minimum length of the culvert shall be 10.91 metres (36 ft.).                                |
| 6    | NIL .....                                  | (6) Roads having R/W 18.29 m (60 ft.) and less than 24.38 m (80 ft.).<br>(i) Minimum length of the culvert shall be 14.64 metres (48 ft.). |
| 7    | NIL .....                                  | (7) Roads having R/W 24.38 m (80 ft.) and above.<br>(i) Minimum length of the culvert shall be metalled width + width of foot-paths.       |

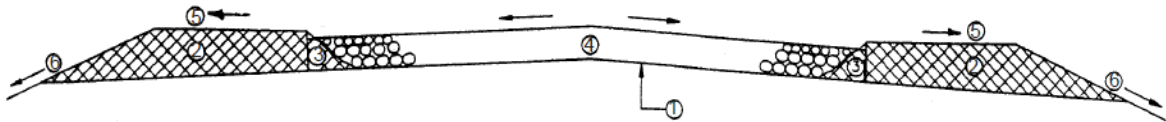
**Notes :**

- (i) Slab of the culvert shall be of R.C. C. M-150 with suitable reinforcement.
- (ii) Minimum thickness of R.C.C. slab shall be 0.1524 m (6") for culverts in residential areas and 0.2286 m (9") for culverts in industrial areas.
- (iii) Maximum span of the culverts slab shall be 1.165 m (4 ft.) C/C.
- (iv) 0.9144 m high parapet of brick masonry and plastered with cement mortar 1:4 (1 cement: 4 coarse sand) finished with a floating coat of neat cement will be constructed on both sides of culvert.



## PROVISION FOR LATERAL CONFINEMENT OF AGGREGATES

Sub Head : Road Work  
Clause: 16.7.5



### STAGES OF CONSTRUCTION

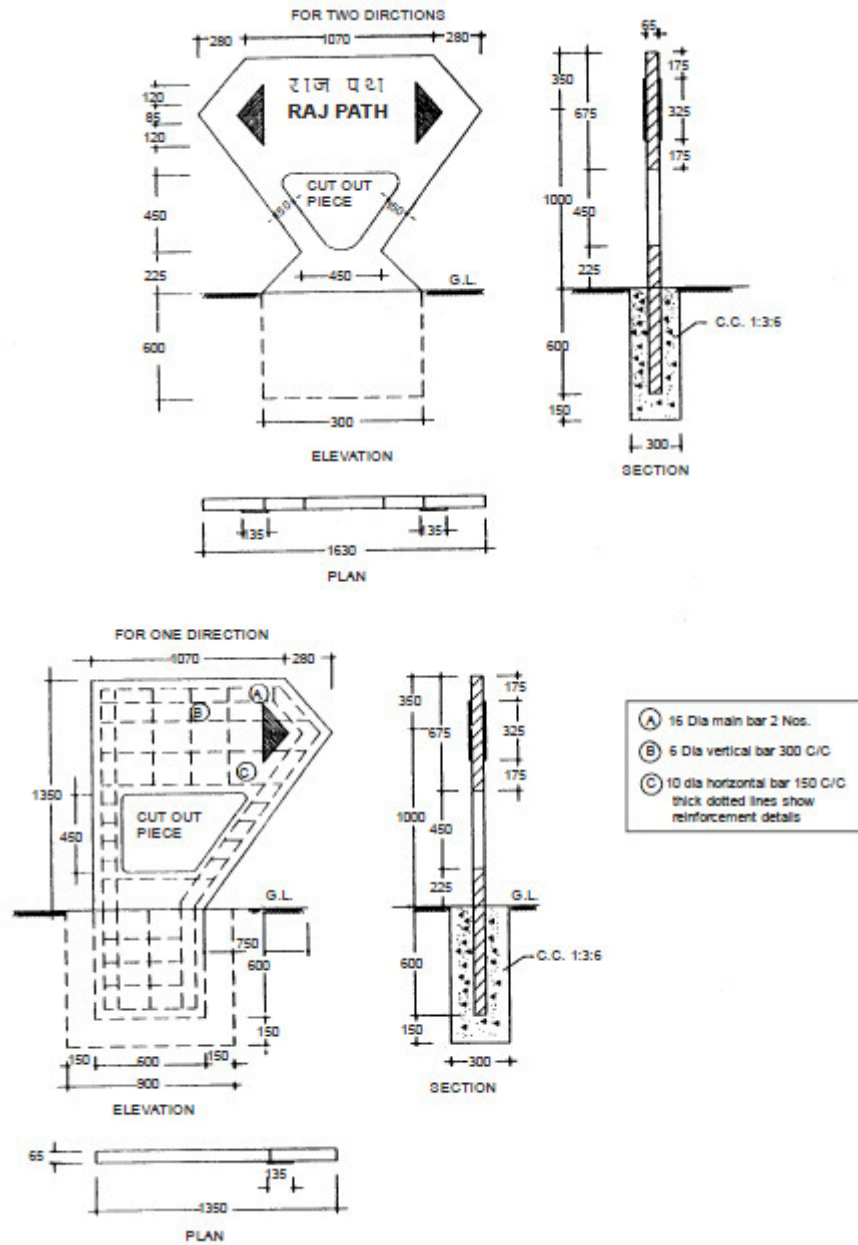
- ① Completion of Subgrade Level
- ② Completion of Shoulder
- ③ Trimming of Shoulder
- ④ WBM in Layers
- ⑤ Finishing Shoulder Top to Lines & Levels
- ⑥ Finishing Side Slopes to Lines & Levels

Drawing not to Scale  
All dimensions are in mm

Fig. 16.1 : Provision for Lateral Confinement of Aggregates

# R.C.C. NAME BOARD WITHOUT POST

Sub Head : Road Work

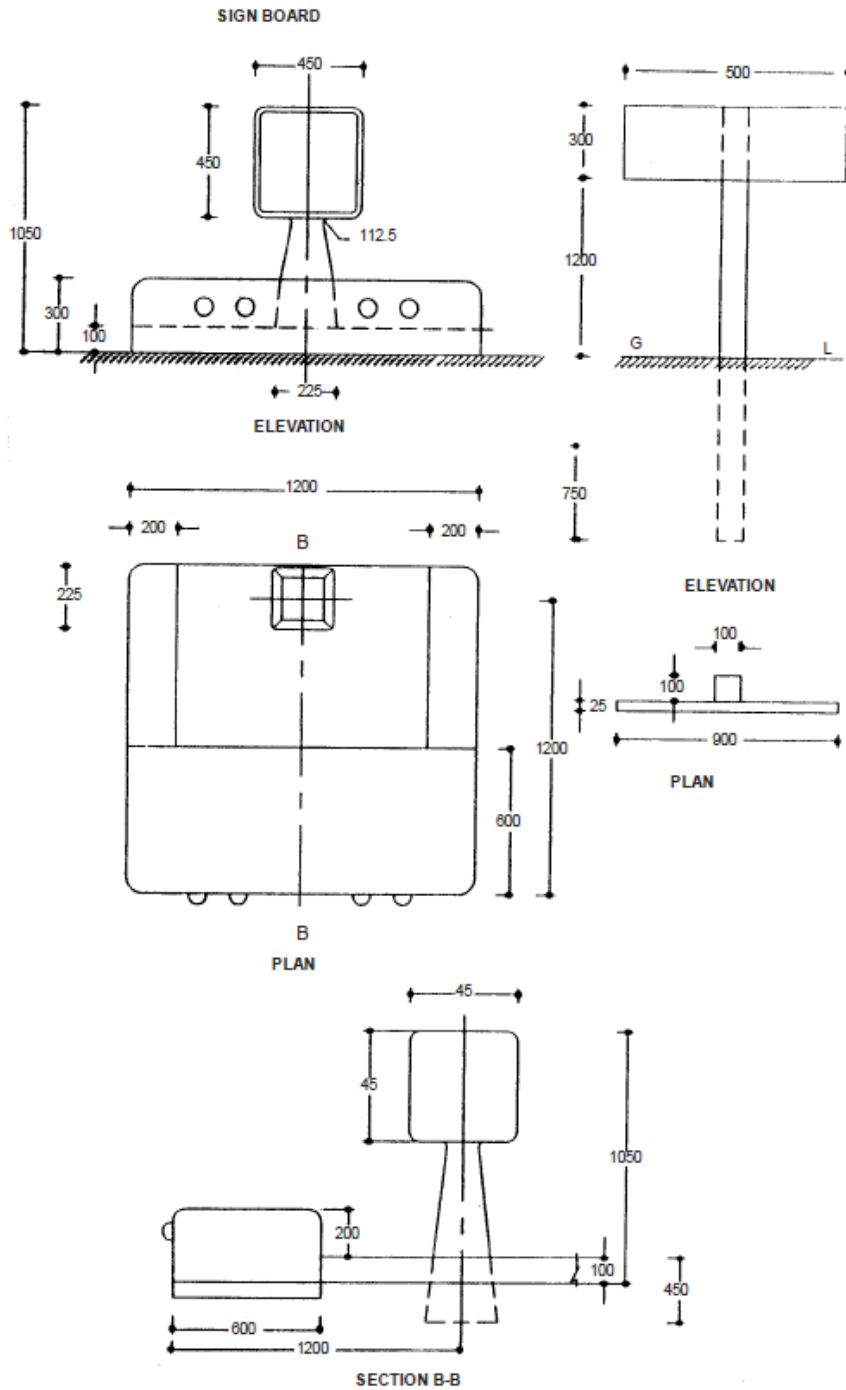


Drawing not to Scale  
All dimensions are in mm

Fig. 16.2 : R.C.C. Name Board without Post

# SIGN/NAME BOARD

Sub Head : Road Work

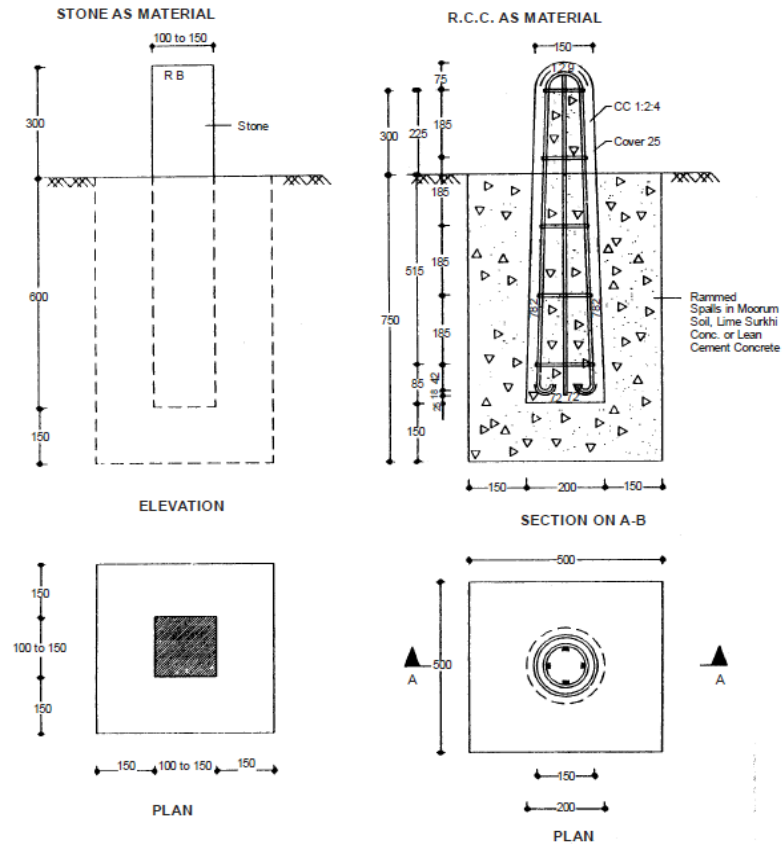


Drawing not to Scale  
 All dimensions are in mm  
 Red Reflectors ○ ◻

Fig. 16.3 : Sign/Name Board

# BOUNDARY STONE

Sub Head : Road Work  
Clause : 16.20 & 16.21



| BAR BENDING SCHEDULE |                        |             |               |           |                         |
|----------------------|------------------------|-------------|---------------|-----------|-------------------------|
| S. No.               | Type of M.S. Bar       | No. of Bars | Shape of Bars | Dia in mm | Length of Bars I/S Hook |
| 1.                   | Main Bars              | 2           |               | 6         | 1840                    |
| 2.                   | Top Most Stirrup       | 1           |               | 6         | 370                     |
| 3.                   | Stirrup 1st from Top   | 1           |               | 6         | 405                     |
| 4.                   | Stirrup Sec. from Top  | 1           |               | 6         | 440                     |
| 5.                   | Stirrup Third from Top | 1           |               | 6         | 475                     |
| 6.                   | Bottom Most Stirrup    | 1           |               | 6         | 510                     |

Drawing not to Scale  
All Dimensions are in mm

Fig. 16.4 : Boundary Stone

## STANDARD NUMERALS

Sub Head : Road Work  
Clause : 16.19

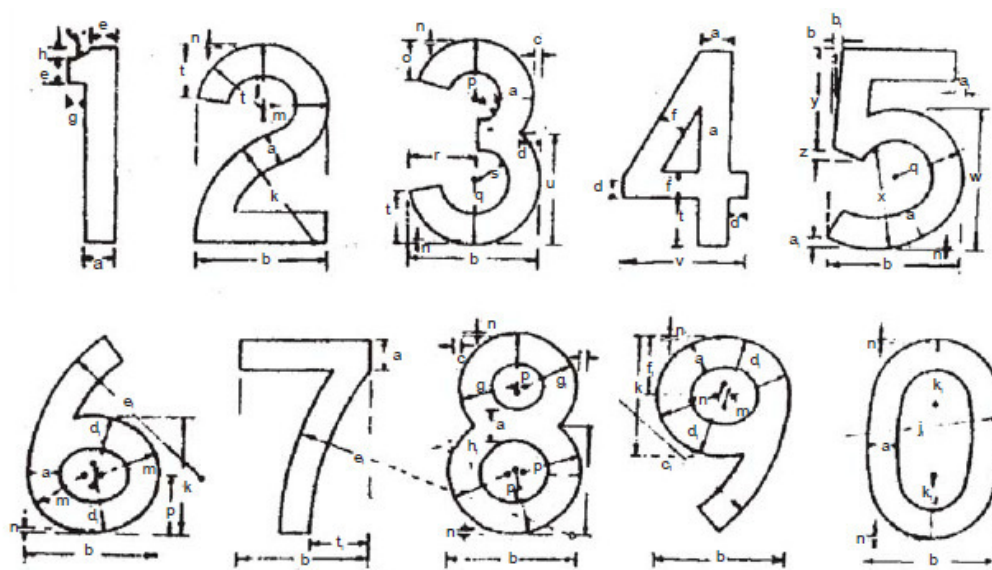


TABLE - I

| Height of Numeral | DIMENSIONS |                |    |                |   |                |    |                |    |                |    |                |    |                |   |                |    |                |    |                |    |                |    |    |   |    |    |    |    |    |    |    |    |    |    |    |   |
|-------------------|------------|----------------|----|----------------|---|----------------|----|----------------|----|----------------|----|----------------|----|----------------|---|----------------|----|----------------|----|----------------|----|----------------|----|----|---|----|----|----|----|----|----|----|----|----|----|----|---|
|                   | a          | a <sub>1</sub> | b  | b <sub>1</sub> | c | c <sub>1</sub> | d  | d <sub>1</sub> | e  | e <sub>1</sub> | f  | f <sub>1</sub> | g  | g <sub>1</sub> | h | h <sub>1</sub> | i  | i <sub>1</sub> | j  | j <sub>1</sub> | k  | k <sub>1</sub> | l  | m  | n | o  | p  | q  | r  | s  | t  | u  | v  | w  | x  | y  | z |
| 80                | 13         | 4              | 54 | 2              | 3 | 71             | 8  | 29             | 10 | 120            | 11 | 24             | 7  | 21             | 5 | 9              | 26 | 56             | 31 | 80             | 46 | 26             | 21 | 23 | 1 | 16 | 24 | 27 | 28 | 12 | 20 | 45 | 51 | 58 | 41 | 41 | 4 |
| 100               | 16         | 5              | 67 | 2              | 4 | 89             | 9  | 36             | 13 | 150            | 14 | 30             | 9  | 26             | 6 | 12             | 33 | 70             | 39 | 100            | 61 | 32             | 27 | 29 | 2 | 20 | 30 | 34 | 34 | 15 | 25 | 56 | 64 | 72 | 51 | 52 | 5 |
| 130               | 20         | 7              | 87 | 3              | 5 | 116            | 12 | 47             | 16 | 195            | 18 | 39             | 11 | 34             | 8 | 15             | 43 | 91             | 51 | 130            | 79 | 42             | 35 | 38 | 2 | 26 | 40 | 44 | 45 | 19 | 33 | 73 | 83 | 93 | 66 | 67 | 6 |

TABLE - II  
SPACING BETWEEN NUMERAL

| Code Number | Numeral Height |     |     |
|-------------|----------------|-----|-----|
|             | 80             | 100 | 130 |
| 1           | 19             | 24  | 31  |
| 2           | 15             | 19  | 24  |
| 3           | 10             | 13  | 16  |
| 4           | 5              | 6   | 8   |

TABLE - III  
NUMERAL CODE NUMBER

| Preceding Numeral | Following Numeral |                  |      |
|-------------------|-------------------|------------------|------|
|                   | 1, 5              | 2, 3, 6, 8, 9, 0 | 4, 7 |
| 1                 | 1                 | 1                | 2    |
| 2                 | 1                 | 2                | 2    |
| 3                 | 1                 | 2                | 2    |
| 4                 | 2                 | 2                | 4    |
| 5                 | 1                 | 2                | 2    |
| 6                 | 1                 | 2                | 2    |
| 7                 | 2                 | 2                | 4    |
| 8                 | 1                 | 2                | 2    |
| 9                 | 1                 | 2                | 2    |
| 0                 | 1                 | 2                | 2    |

**Note :** To determine the proper spacing between numerals obtain the code number from Table III and enter Table II for that Code Number to Desired Numeral Height. Spacing is measured horizontally from the extreme right edge of the preceding numeral to the extreme left of the following numeral. For Dimensions of numerals of different heights see Table I.

Drawing not to scale  
All dimensions are in mm

**Fig. 16.5 : Standard Numerals**

# STANDARD LETTERS

Sub Head : Road Work  
Clause : 16.19



TABLE - II

| Height of Letter | DIMENSIONS |    |     |    |    |     |    |    |    |    |   |    |    |    |    |   |    |    |    |    |   |    |    |   |    |    |    |    |    |     |     |    |   |     |    |    |    |    |    |    |     |    |    |    |     |   |   |   |   |   |   |
|------------------|------------|----|-----|----|----|-----|----|----|----|----|---|----|----|----|----|---|----|----|----|----|---|----|----|---|----|----|----|----|----|-----|-----|----|---|-----|----|----|----|----|----|----|-----|----|----|----|-----|---|---|---|---|---|---|
|                  | a          | a  | b   | b  | c  | c   | d  | d  | e  | e  | f | f  | g  | g  | h  | h | i  | i  | j  | j  | k | k  | l  | l | m  | m  | n  | n  | o  | o   | p   | p  | q | q   | r  | r  | s  | s  | t  | t  | u   | u  | v  | v  | w   | w | x | x | y | y | z |
| 80               | 13         | 31 | 67  | 56 | 23 | 62  | 56 | 46 | 35 | 27 | 2 | 11 | 42 | 6  | 20 | 4 | 22 | 14 | 13 | 26 | 3 | 25 | 26 | 3 | 26 | 60 | 16 | 10 | 18 | 70  | 63  | 51 | 1 | 58  | 29 | 11 | 56 | 8  | 23 | 49 | 80  | 12 | 14 | 50 | 28  |   |   |   |   |   |   |
| 100              | 16         | 39 | 84  | 69 | 28 | 77  | 67 | 58 | 44 | 34 | 2 | 14 | 52 | 8  | 25 | 5 | 27 | 17 | 16 | 30 | 3 | 31 | 33 | 4 | 32 | 79 | 20 | 13 | 22 | 88  | 73  | 64 | 2 | 84  | 36 | 13 | 70 | 9  | 29 | 61 | 100 | 15 | 18 | 5  | 34  |   |   |   |   |   |   |
| 130              | 20         | 51 | 109 | 89 | 37 | 101 | 87 | 75 | 57 | 44 | 3 | 18 | 68 | 10 | 33 | 6 | 36 | 22 | 21 | 40 | 4 | 31 | 43 | 4 | 42 | 98 | 28 | 16 | 28 | 116 | 100 | 83 | 2 | 110 | 47 | 17 | 91 | 12 | 36 | 79 | 130 | 19 | 23 | 8  | 145 |   |   |   |   |   |   |

TABLE - II  
SPACING BETWEEN LETTERS

| Code Number | Height of Letter |     |     |
|-------------|------------------|-----|-----|
|             | 80               | 100 | 130 |
| 5           |                  |     |     |
| 12          | 19               | 24  | 31  |
| 9           | 15               | 19  | 24  |
| 6           | 10               | 13  | 16  |
| 3           | 5                | 6   | 8   |

TABLE - III  
LETTER CODE NUMBER

| Preceding Letter | Following Letter                      |                     |                  |
|------------------|---------------------------------------|---------------------|------------------|
|                  | B, D, E, F, H, I, K, L, M, N, P, R, U | C, G, O, Q, S, X, Z | A, J, T, U, W, Y |
| A                | 2                                     | 2                   | 4                |
| B                | 1                                     | 2                   | 2                |
| C                | 2                                     | 2                   | 3                |
| D                | 1                                     | 2                   | 2                |
| E                | 2                                     | 2                   | 3                |
| F                | 2                                     | 2                   | 3                |
| G                | 1                                     | 2                   | 2                |
| H                | 1                                     | 1                   | 2                |
| I                | 1                                     | 1                   | 2                |
| J                | 1                                     | 1                   | 2                |
| K                | 2                                     | 2                   | 3                |
| L                | 2                                     | 2                   | 4                |
| M                | 1                                     | 1                   | 2                |
| N                | 1                                     | 1                   | 2                |
| O                | 1                                     | 2                   | 2                |
| P                | 1                                     | 2                   | 2                |
| Q                | 1                                     | 2                   | 2                |
| R                | 1                                     | 2                   | 2                |
| S                | 1                                     | 2                   | 2                |
| T                | 2                                     | 2                   | 4                |
| U                | 1                                     | 2                   | 2                |
| V                | 2                                     | 2                   | 4                |
| W                | 2                                     | 2                   | 4                |
| X                | 2                                     | 2                   | 3                |
| Y                | 2                                     | 2                   | 4                |
| Z                | 2                                     | 2                   | 3                |

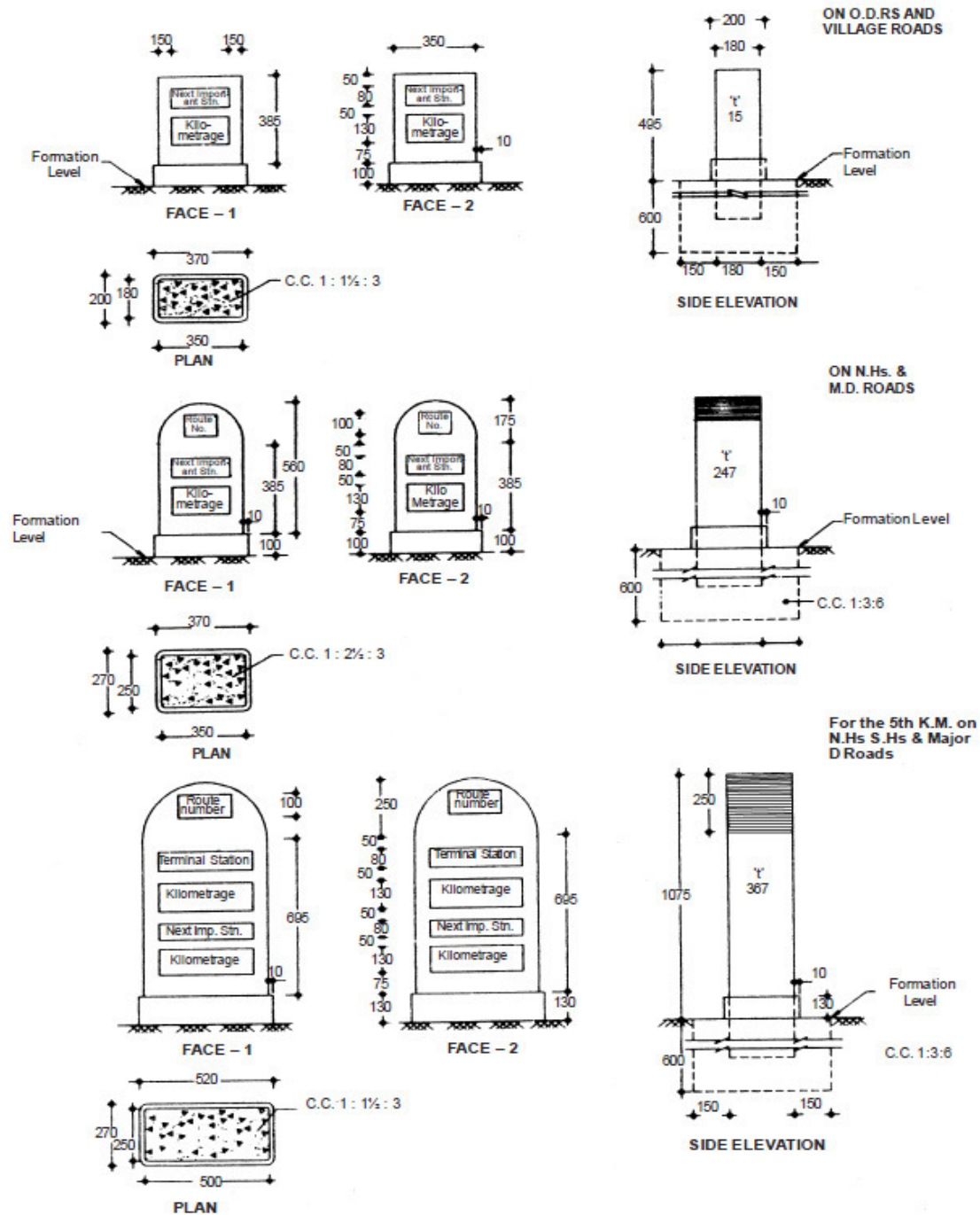
**Note :** To determine the proper spacing between letters obtain the code number from Table III and enter Table II for that Code Number to Desired Height. Spacing is measured horizontally from the extreme right edge of the preceding Letter to the extreme left edge of the following letter. For Dimensions of letters of different heights, see Table I.

Drawing not to scale  
All dimensions are in mm

**Fig. 16.6 : Standard Letters**

# KILOMETRE STONES TYPE DESIGN

Sub Head : Road Work  
Clause : 16.22



DRAWING NOT TO SCALE  
ALL DIMENSIONS ARE IN MM.  
RCC THICKNESS 'T' SHALL BE 250  
OTHER MATERIAL

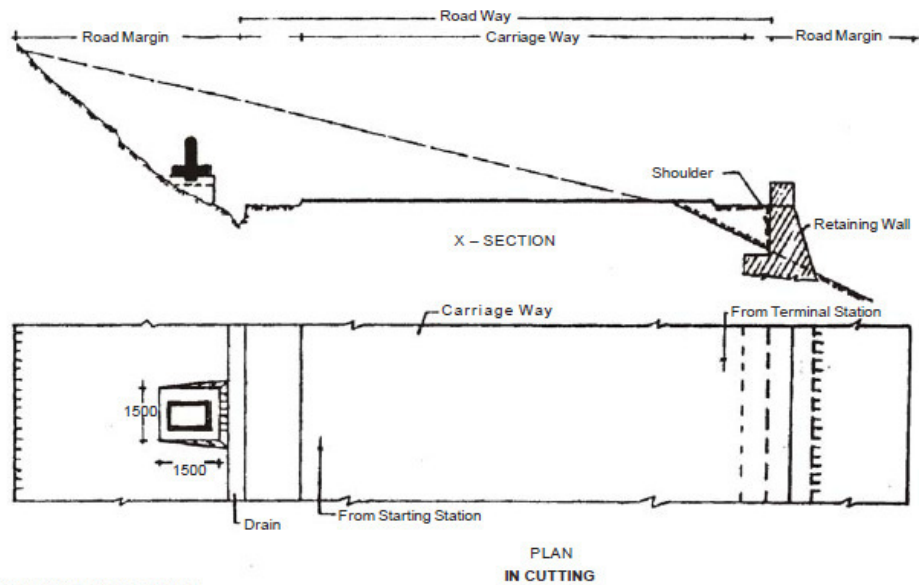
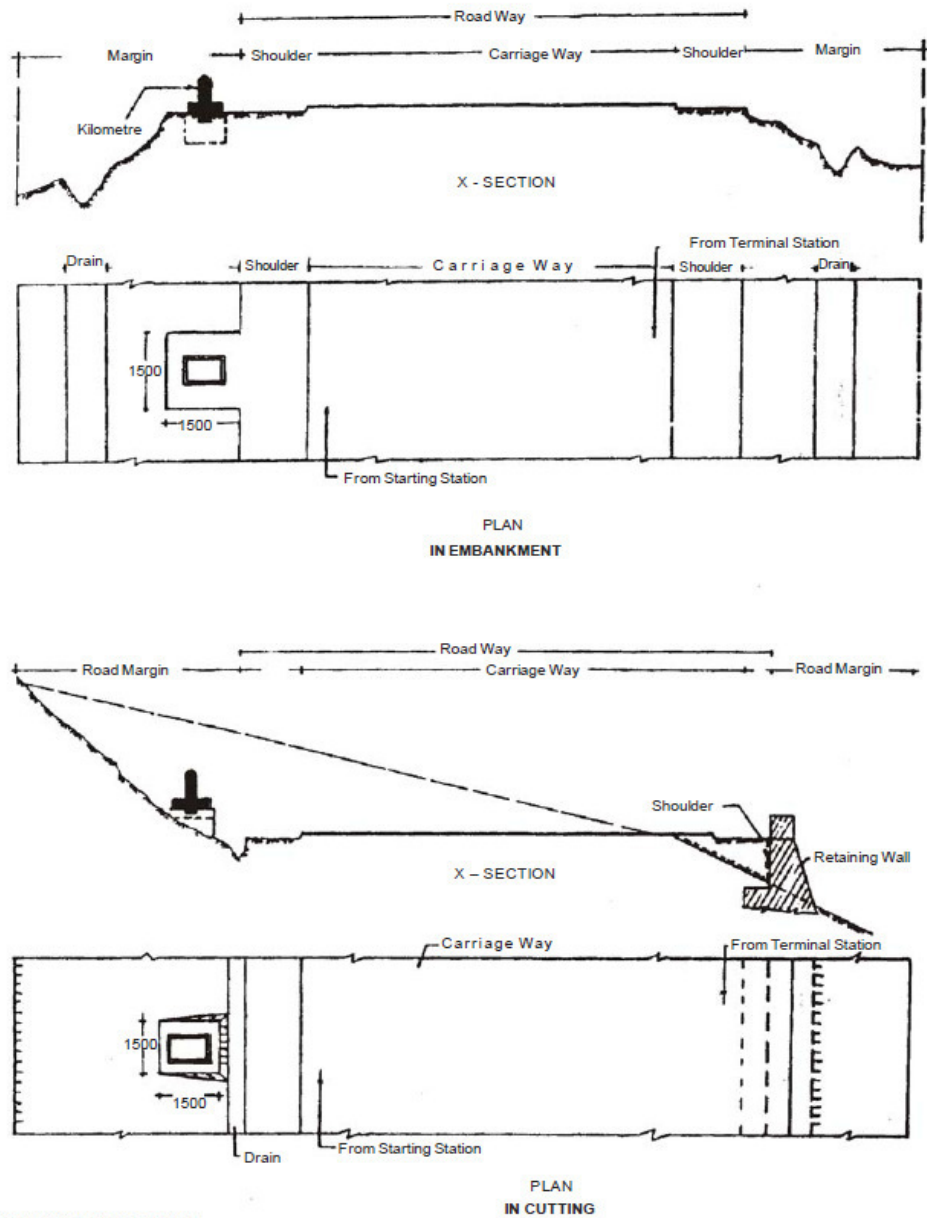
THICKNESS MAY VARY.

Fig. 16.7 : Kilometre Stones Type Design



# KILOMETRE STONE LOCATION (FOR HIGHWAYS)

Sub Head : Road Work  
 Clause : 16.22



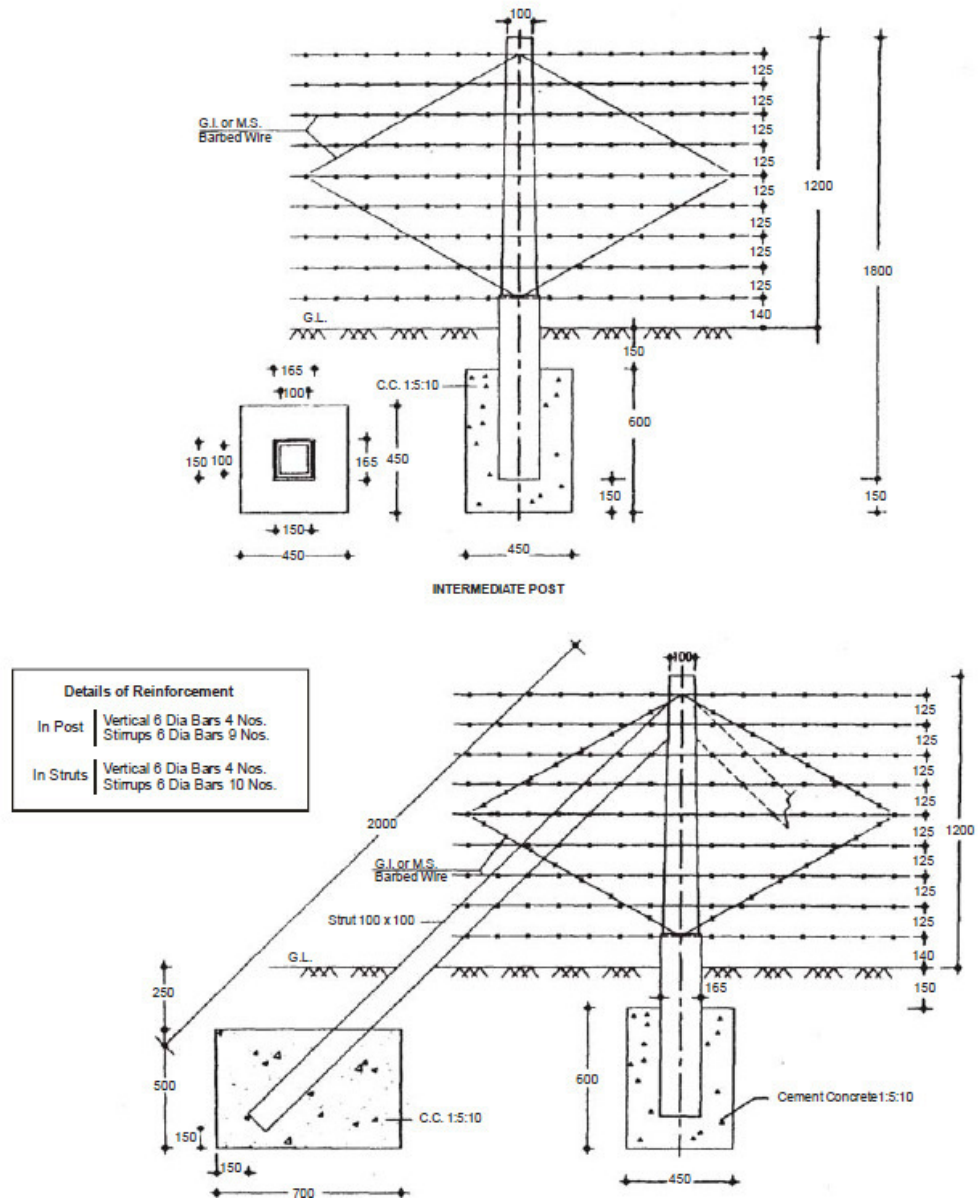
DRAWING NOT TO SCALE  
 ALL DIMENSIONS ARE IN MM

Fig. 16.7A : Kilometre Stones Location (For Highways)



# BARBED WIRE FENCING (WITH R.C.C. POST)

Sub Head : Road Work  
 Clause : 16.16

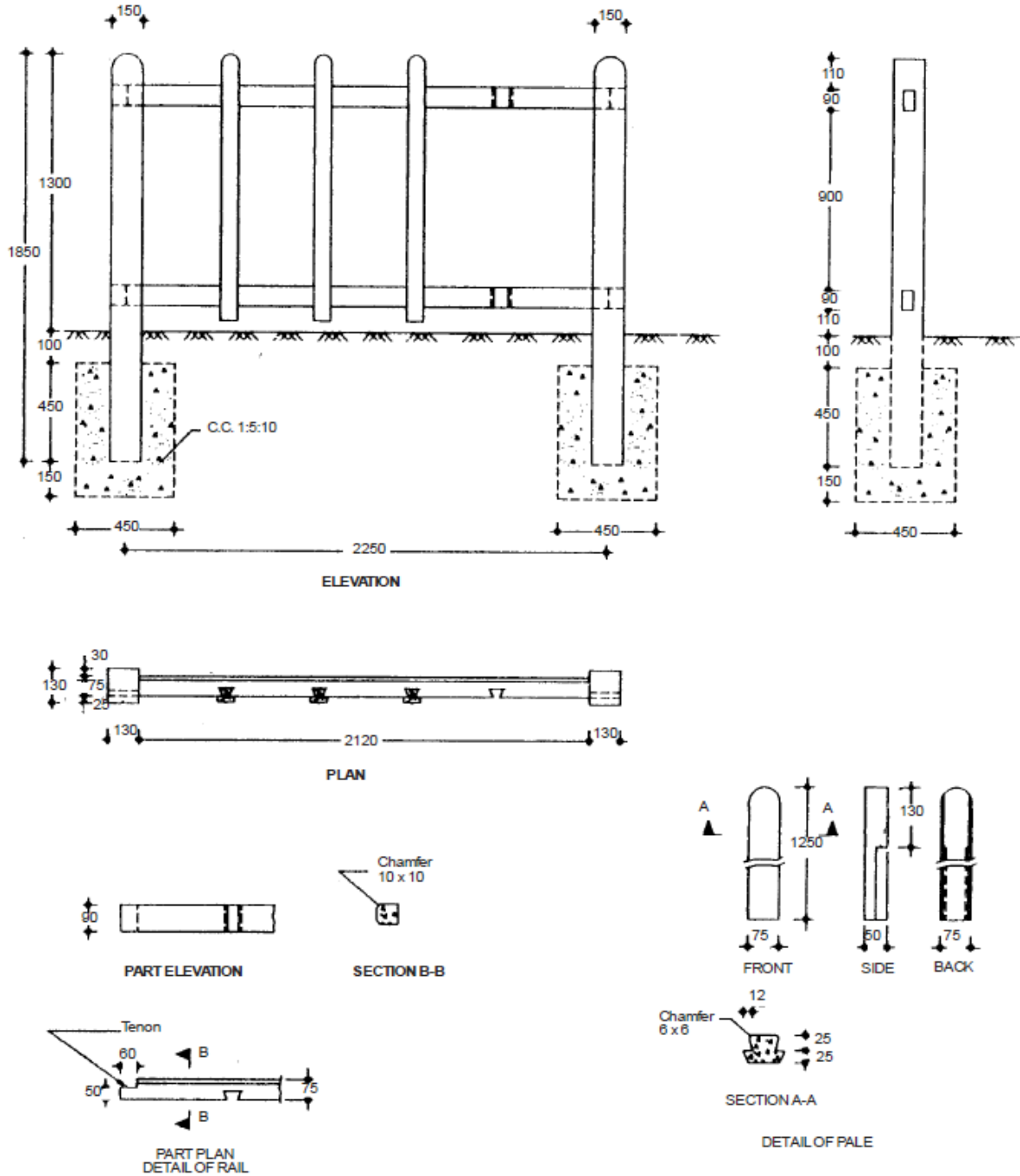


1. In case of end post one strut shall be omitted.
2. Drawing not to Scale
3. All dimensions are in mm.

Fig. 16.9 : Barbed Wire Fencing

# FENCING WITH R.C.C. POST RAILS, PALES

Sub Head : Road Work  
 Clause : 16.18.6



Drawing not to Scale  
 All dimensions are in mm

Fig. 16.10 : Fencing with R.C.C. Post Rails, Pales

# LOCATION OF INFORMATORY SIGN BOARDS

Sub Head : Road Work  
Clause : 16.49

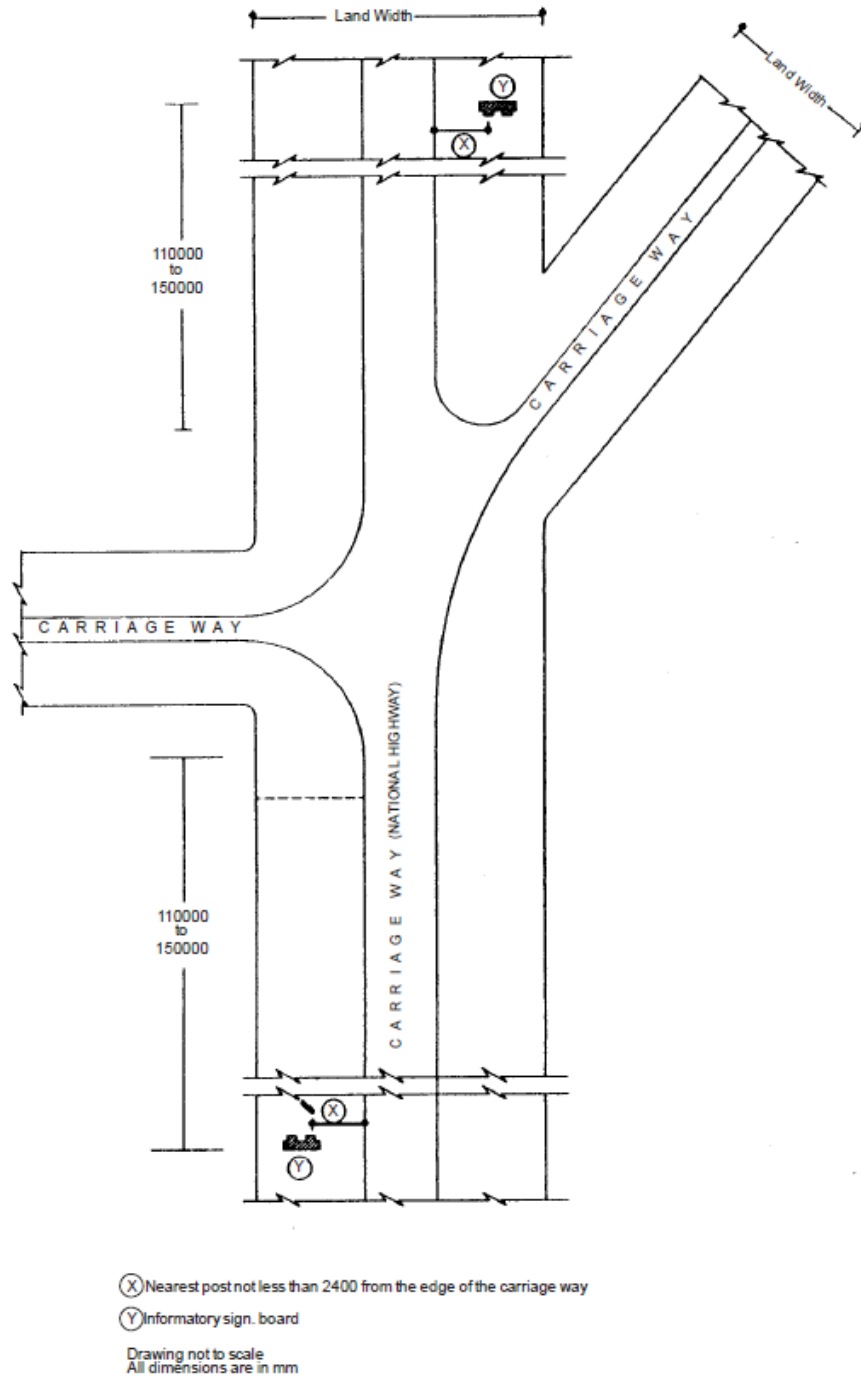
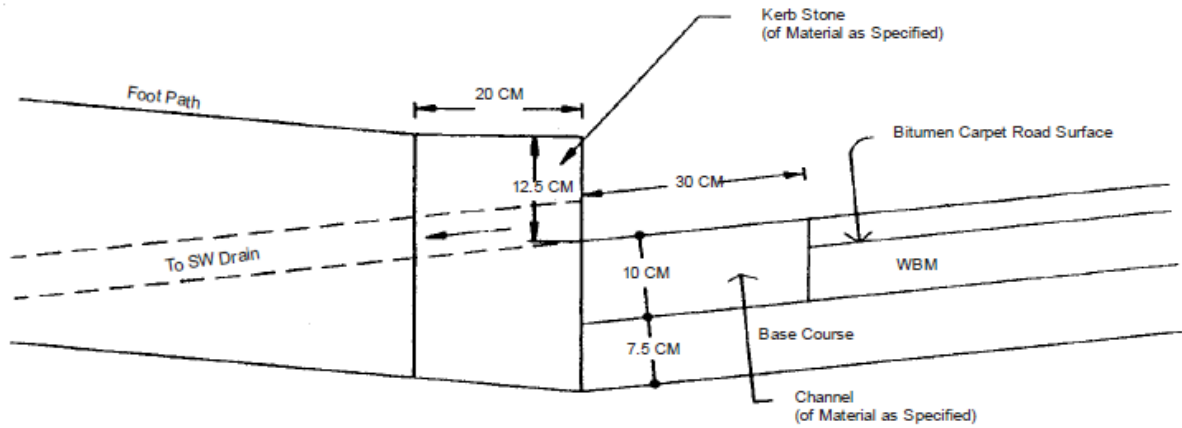


Fig. 16.11 : Location of Informatory Sign Boards

## KERB & CHANNEL STONES

Sub Head : Road Work  
Clause : 16.1.20

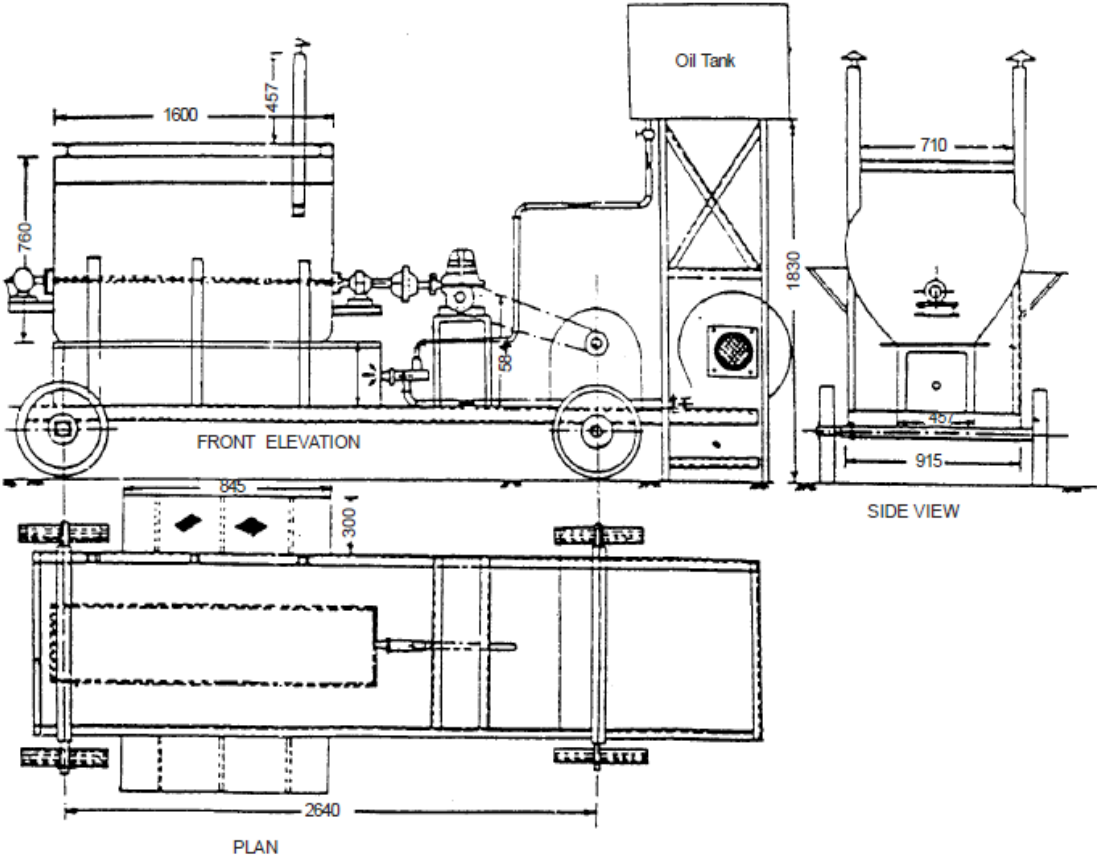


Drawing not to Scale  
All dimensions are in mm

Fig. 16.12 : Kerb & Channel Stones

# BROAD DETAILS OF COOKER FOR BITUMEN MASTIC IN WEARING COURSES

Sub Head : Road Work  
Clause : 16.33.3



Drawing not to Scale.  
All dimensions are in mm.

Fig. 16.13 : Broad Details of Cooker for Bitumen Mastic in Wearing courses





**SUB HEAD : 17.0**

**SANITARY INSTALLATIONS**



## CONTENTS

| <i>Clause No.</i> | <i>Brief Description</i>  | <i>Page No.</i> |
|-------------------|---|-----------------|
|                   | List of Bureau of Indian Standards (BIS) Codes                      | 883             |
| 17.0              | Terminology   | 885             |
| 17.1              | Appliances and Fittings   | 888             |
| 17.1.1            | Flushing Cisterns   | 888             |
| 17.1.2            | Draining Board  | 893             |
| 17.1.3            | Foot Rests  | 894             |
| 17.1.4            | Glass Shelf/ PVC Shelf  | 894             |
| 17.1.5            | Mirror  | 894             |
| 17.1.6            | M S Stays and Clamps  | 894             |
| 17.1.7            | Pillar Taps   | 894             |
| 17.1.8            | Sand Cast Iron or Centrifugally Cast (Spun) Iron Pipes and Fittings | 895             |
| 17.1.8A           | Hubless Centrifugally Cast (Spun) Iron pipes and fittings           | 896             |
| 17.1.9            | Plastic Seat and Covers for Water Closet                            | 897             |
| 17.1.10           | Sinks   | 898             |
| 17.1.11           | Towel Rail  | 898             |
| 17.1.12           | Toilet Paper Holder   | 898             |
| 17.1.13           | Urinals   | 898             |
| 17.1.14           | Wash Basins   | 899             |
| 17.1.15           | Waste Fittings for Wash Basins and Sinks                            | 899             |
| 17.1.16           | Water Closet  | 900             |
| 17.2              | General Requirements for Installation of W. C. Pan                  | 900             |
| 17.3              | Installation of Draining Board                                      | 901             |
| 17.4              | Installation of Flushing Cistern                                    | 902             |

|            |  |     |
|------------|--|-----|
| 17.5       | Installation of Mirror   | 902 |
| 17.6       | Fixing and Jointing of Pipes and Fittings  | 902 |
| 17.7       | Installation of Seat and Cover to Water Closet   | 905 |
| 17.8       | Installation of Sink   | 905 |
| 17.9       | Installation of Urinal - Lipped, Half Stall (Single or Range)                                    | 905 |
| 17.10      | Installation of Stall Urinal (Single or Range)   | 906 |
| 17.11      | Installation of Wash Basin   | 907 |
| 17.12      | Installation of Squatting Pan  | 907 |
| 17.13      | Installation of Water Closet   | 908 |
| 17.14      | Installation of Foot Rests   | 908 |
| 17.15      | Installation of Squatting Plate (Single or Range)  | 908 |
| 17.16      | Installation of Towel Rail   | 909 |
| 17.17      | Installation of Stainless Steel Sink   | 909 |
| 17.18      | Cutting Chase in Masonry Wall  | 910 |
| 17.19      | Painting Synthetic Enamel Paint on SCI/Centrifugally Cast (Spun) Iron Soil, Waste and Vent Pipes | 910 |
| 17.20      | Repainting SCI/Centrifugally Cast (Spun) Iron Soil, Waste and Vent Pipe                          | 911 |
| 17.21      | Installation of Wall Mounting Water Closet (WC)  | 911 |
| 17.22      | Installation of Floor Mounted Single Piece Water Closet (WC)                                     | 912 |
| Appendix A | Standard Weights and Thickness of C.I. Pipes   | 913 |
| Appendix B | Drawing and dimensions for stainless steel shielded coupling                                     | 914 |
| Fig. 17.1  | Pipe Systems and Parts   | 916 |
| Fig. 17.2  | Pipe Systems and Parts   | 916 |
| Fig. 17.3  | Flushing Cisterns  | 917 |

|            |  |     |
|------------|--|-----|
| Fig. 17.4  | Foot Rest  | 918 |
| Fig. 17.5  | M.S. Stays and Clamp   | 919 |
| Fig. 17.6  | Plastic Seat and Cover   | 920 |
| Fig. 17.7  | Kitchen & Laboratory Sinks   | 921 |
| Fig. 17.8  | Waste Fittings for W.B. & Sinks  | 922 |
| Fig. 17.9  | Urinal Bowl Type   | 923 |
| Fig. 17.10 | Urinal Bowl Type (Corner Wall Type)  | 924 |
| Fig. 17.11 | Urinal - Half Stall  | 925 |
| Fig. 17.12 | Urinal Squatting Plate   | 926 |
| Fig. 17.13 | Spreader for Urinal  | 927 |
| Fig. 17.14 | Wash Basins  | 928 |
| Fig. 17.15 | Fixing Arrangement of Wash Basins  | 929 |
| Fig. 17.16 | Typical Vertical Section of Wash Basins (Waste Pipe Open to View)                          | 930 |
| Fig. 17.17 | Typical Vertical Section of Wash Basin (Waste Pipe Concealed from View)                    | 931 |
| Fig. 17.18 | Angle Back Wash Basin (Pattern-2)  | 932 |
| Fig. 17.19 | Long Pattern Squatting Pan (Type-I)  | 933 |
| Fig. 17.20 | Orissa Pattern Squatting Pan   | 934 |
| Fig. 17.21 | Integrated Squatting Pan   | 935 |
| Fig. 17.22 | Pattern 1 and Pattern 2-Water Closets  | 936 |
| Fig. 17.23 | Pattern 3-Water Closet with Horizontal P-Trap  | 937 |
| Fig. 17.24 | Typical coupling joint-installation  | 938 |
| Fig.17.25  | Typical illustration of Wall Mounted Water Closet with Concealed Outlet (Pattern 1)        | 939 |
| Fig.17.26  | Typical illustration of Water Closet with fixing arrangement on top of Bracket (pattern 2) | 940 |





**LIST OF BUREAU OF INDIAN STANDARDS (BIS) CODES**

| <i>S. No.</i> | <i>BIS. No.</i>    | <i>Subject</i>  |
|---------------|--------------------|---|
| 1.            | IS 771 (Pt.1)      | Specification for glazed fire clay sanitary appliances: Part 1: General requirements.                                     |
| 2.            | IS 771 (Pt.-2)     | Specification for glazed fire clay sanitary appliances: Part 2: Specific requirements of kitchen and laboratory sink.     |
| 3.            | IS 772             | Specific action for general requirements for enameled cast iron sanitary appliances.                                      |
| 4.            | IS 774             | Flushing cisterns for water closets and urinals (Other than plastic cistern)-Specifications.                              |
| 5.            | IS 1300            | Phenolic moulding materials.- Specifications  |
| 6.            | IS 13983           | Providing and fixing stainless steel sink   |
| 7.            | IS 1570 (Part-5)   | Schedule for Wrought steel (Stainless Steel and heat resisting steels)  |
| 8.            | IS 1703            | Water fittings- copper alloy float valves (horizontal plunger type) - Specification.                                      |
| 9.            | IS 1729            | Cast iron /Ductile Iron Drainage Pipes and pipe fittings for Over ground non-pressure pipe line Socket and Spigot Series. |
| 10.           | IS 1795            | Specification for pillar taps for water supply purposes.  |
| 11.           | IS 1865            | Iron casting with spheroidal or nodular graphite  |
| 12.           | IS 2267            | Polystyrene moulding and extrusion materials - Specifications   |
| 13.           | IS 2326            | Specification for Automatic Flushing Cisterns for Urinals (Other than plastic cisterns)                                   |
| 14.           | IS 2548 (Part-1)   | Plastic seats and covers for water closets Part 1: Thermo set seats and covers - Specifications                           |
| 15.           | IS 2548 (Part-2)   | Plastic seats and covers for water closets Part 2: Thermoplastic seats and covers.- Specifications                        |
| 16.           | IS 2556            | Vitreous sanitary appliances (vitreous china) -Specifications   |
| 17.           | IS 2556 (Part-1)   | Part-1: General requirements.   |
| 18.           | IS 2556 (Part-2)   | Part-2: Specific requirements of wash-down water closets.   |
| 19.           | IS 2556 (Part-3)   | Part-3: Specific squatting pans.  |
| 20.           | IS 2556 (Part-4)   | Part-4: Specific requirements of wash basins.   |
| 21.           | IS 2556 (Part-5)   | Part-5: Specific requirements of laboratory sinks.  |
| 22.           | IS 2556 (Part-6)   | Part-6: Specific requirements of Urinals & Partition plates   |
| 23.           | IS 2556 (Part-7)   | Part-7: Specific requirements of accessories for sanitary appliances  |
| 24.           | IS 2556 (Part -14) | Part-14: Specific requirements of integrated squatting pans.  |

|     |                    |  |
|-----|--------------------|--|
| 25. | IS 2556 (Part -15) | Part-15: Specific requirements of universal water closets.   |
| 26. | IS 2556 (Part -16) | Part-16: Specific requirements of wash down wall mounted water closets   |
| 27. | IS 2963            | Specification for Copper alloy waste fittings for wash basins and sinks.   |
| 28. | IS 3076            | Specification for low density polyethylene pipes for potable water supplies.   |
| 29. | IS 3389            | Urea formaldehyde moulding materials. - Specifications   |
| 30. | IS 3989            | Specification for centrifugally cast (spun) iron spigot and socket soil, waste and ventilating pipes fittings and accessories. |
| 31. | IS 4827            | Specification for electroplated coating of nickel and chromium on copper and copper alloys.                                    |
| 32. | IS 4984            | Specification for high density polyethylene pipes for potable water supplies.  |
| 33. | IS 4985            | Unplasticised P.V.C. pipes for potable water supply - Specifications.  |
| 34. | IS 7231            | Plastic flushing cisterns for water closets and urinals - Specifications.  |
| 35. | IS 13983           | Stainless steel sinks for domestic purposes -Specifications.   |
| 36. | IS 15905           | Centrifugally Cast Iron Hubless pipes & fittings   |

## 17.0 SANITARY INSTALLATIONS

### 17.0 TERMINOLOGY

#### **Antisiphon Pipe (Fig. 17.1)**

A ventilating pipe connected to or close to the outlet side of a trap seal.

#### **Automatic Flushing Cistern (Fig. 17.3)**

A flushing cistern arranged to discharge its content by siphonage at regular intervals, determined by the rate at which water is fed into the cistern.

#### **Ball Cock (Fig. 17.3)**

A faucet opened or closed by the fall or rise of a ball floating in the surface of water.

#### **Ball Valve (Fig. 17.3)**

A simple non return valve consisting of a ball resting on a cylindrical seat within a fluid passageway.

#### **Bell Mouth (Fig. 17.3)**

An expanded rounded entrance to a pipe or orifice.

#### **Bend**

Length of pipe bent or cast into an angle shape.

#### **Bib Tap**

A tap with a horizontal inlet and nozzle bent to discharge in a downward direction.

#### **Blister**

A raised portion of the surface protruding not more than one millimeter above the surface and not greater than 3 mm in its greatest dimension.

#### **Box Union**

A device for joining two threaded pipes.

#### **Branch (Fig. 17.1)**

- (a) A special form of vitrified sewer and cast iron pipe used for making connections to a sewer or water main. The various types are called T, Y, T-Y, double Y, and V branches, according to their respective shapes.
- (b) Any part of piping system other than a main.

#### **Caulking**

- (a) The process of driving, pouring or forcing lead, oakum, plastic or other material into a joint to make it leak proof.
- (b) The material used in the caulking process.

#### **Caulked Joint**

A spigot and socket joint in which the jointing material is compacted by means of caulking tool and hammer.

**Chase**

A continuous recess in wall, floor or ceiling for the purpose of holding pipes and conduits.

**Cistern (Fig. 17.3)**

A fixed container for water in which the water is at atmospheric pressure. The water is usually supplied through a ball valve.

**Collar**

A pipe-fitting in the form of sleeve for jointing the spigot ends of two pipes in the same alignment.

**Cowl (Fig. 17.1)**

A hood on the top of a vent pipe or soil stack.

**Craze or crazing**

Fine cracks in the glaze.

**Cross**

A pipe fitting used for connecting four pipes at right angles.

**Fittings**

Coupling, flange, branch, bend, tee, elbow, union, waste with plug, P or S trap with vent, ferrule, stop tap, bib tap, pillar tap, globe tap, ball valve, cistern, storage tank, baths, water closets, boiler geyser, pumping set with motor and accessories, metre, hydrant valve and any other article used in connection with water supply, drainage and sanitation.

**Float Valve (Fig. 17.3)**

A valve in which the closure to an opening such as a plug or gate, is actuated by a float to control the flow in to a tank.

**Flush Bend**

A bend located at the bottom of low level flushing cistern for the purpose of flushing pedestal type water closet and similar fixture.

**Flushing Cistern (Fig. 17.3)**

A cistern provided with a device for rapidly discharging the contained water and used in connection with a sanitary appliance for the purpose of cleaning the appliance and carrying away its contents into a drain.

**Gasket**

A piece of compressible material used to make a joint between two flat surfaces.

**Oakum**

Hemp or old hemp rope soaked in oil to make it water proof.

**One Pipe System (Fig. 17.1)**

In this a single soil waste pipe conveys both soil and waste directly to the building drain.

**Pinhole**

A hole in the body, less than 1.5 mm, in its maximum dimension.

**Reducer**

A pipe-fitting with inside threads larger at one end than at the other. All such fittings having more than one size are reducers because of the custom of stating the larger size first.

**Single Stack System (Fig. 17.1)**

This is the name given to a simplified one pipe system wherein all ventilation pipes are omitted. The stack itself is made to cater (or provide) for all the vent requirements by restricting the flow into the stack to certain predetermined limits.

**Sink (Fig. 17.7)**

A shallow fixture, ordinarily with a flat bottom, that is usually used in kitchen or in connection with the preparation of food, laboratory purposes and for certain industrial processes.

**Socket**

The female part of spigot and socket joint.

**Soil Pipe**

A pipe which conveys to drain the discharge from a water closet or urinals. In 'One pipe' and 'single stack' system the soil pipe also conveys to a drain the discharges from bath, wash basins, sinks and similar appliances.

**Speck**

Area of the finished surface with contrasting colour less than one millimeter maximum dimension.

**Spigot**

The male part of a spigot and socket joint.

**Spigot and Socket Joint**

Joint in which the end of the one pipe enters the enlarged end of the next pipe.

**Stack**

A main vertical discharge or ventilating pipe.

**Trap**

A fitting or device so designed and constructed as to provide, when properly vented, a liquid seal which will prevent the back passage of air without materially affecting the flow of sewage or waste water through it.

**Two Pipe System (Fig. 17.1)**

In this, the soil pipe conveys discharges from water closets, urinals, and similar soil appliances directly to the drainage system and the waste pipe conveys waste from ablutionary and culinary appliances to the drainage system directly or through a trapped gully where desired.

**Union**

A pipe fitting used for joining the ends of two pipes neither of which can be turned.

**Valve**

A device used for controlling the flow of liquid in a line of pipe.

**Ventilating Pipe (Vent Pipe)**

The pipe which provides a safe outlet into the atmosphere for the foul gases in the drain or sewer.

**Warping**

Distortion of original shape during manufacturing process.

**Water Seal**

The depth of water which should be removed from a fully charged trap before air can pass through the trap.

**Waste Pipe**

A pipe used to convey liquid waste not containing human excreta.

**Waste Stack**

A vertical pipe used to convey liquid waste not containing human excreta.

**17.1 APPLIANCES AND FITTINGS**

**17.1.0** All vitreous sanitary appliances (Vitreous China) shall conform to IS 2556 (Part-I) general requirements.

**17.1.1 Flushing Cisterns (Fig. 17.3)**

The flushing cisterns shall be automatic or manually operated high level or low level as specified, for water closets and urinals. A high level cistern is intended to operate with minimum height of 125 cm and a low level cistern with a maximum height of 30 cm between the top of the pan and the under side of the cistern.

Cisterns shall be of following type (i) Vitreous China (IS 774) for Flushing type (ii) Automatic Flushing Cistern (IS 2326) and (iii) Plastic cisterns (IS 7231).

**17.1.1.1 Vitreous Chine Cisterns :** The thickness of the body including cover shall be not less than 6 mm for vitreous China cisterns. The outlet of each syphon or stand pipe shall be securely connected to the cistern by means of lock nut. The cistern shall be free from manufacturing faults and other defects affecting their utility. All working parts shall be designed to operate smoothly and efficiently. Cistern shall be mosquito proof. A cistern shall be considered mosquito proof only if there is no clearance any where which would permit a 1.6 mm wire to pass through in the permanent position of the cistern i.e. in the flushing position or filling position.

The breadth of a low level cistern, from front to back shall be such that the cover or seat, or both, of water closet pan shall come to rest in a stable position when raised.

The cistern shall be supported on two cast iron brackets of size as approved by the Engineer-in-Charge and embedded in cement concrete 1:2:4 block 100 x 75 x 150 mm. These shall be properly protected by suitable impervious paint. Alternatively the cisterns shall have two holes in the back side above the overflow level for screwing into the wall, supplemented by two cast iron wall supports. A 5 litres cistern, however, may be supported by larger brackets cast on the body of the cistern.

The cistern shall have a removable cover which shall fit closely on it and be secured against displacement. In designs where the operating mechanism is attached to the cover this may be made in two sections, but the section supporting the mechanism shall be securely bolted or screwed to the body. The outlet fitting of each cistern shall be securely connected to the cistern. The nominal internal diameter of cistern outlet shall be not less than  $38 \pm 1$  mm for low level cisterns respectively. The length of the outlet of the cistern shall be  $37 \pm 2$  mm.

Ball valve shall be of screwed type 15 mm in diameter and shall conform to IS 1703. The float shall be made of polyethylene as specified in IS 9762. (The design shall permit the cistern to fill in rapidly and close effectively when the level of water reaches the working water level.)

In the case of manually operated cisterns the siphonic action of the flushing cistern shall be capable of being rapidly brought into action by the operating lever, but shall not self siphon or leak. When tested according to IS 774 the discharge rate shall be  $10 \pm 0.5$  litre in 6 seconds and  $5 \pm 0.5$  litre in 3 seconds for cisterns of capacities 10 litre and 5 litre respectively. The cisterns shall be so designed that there is not appreciable variation in the force of flush during the discharge of the required quantity of water. The cistern shall have a discharge capacity of 5 & 10 litres as specified. When required to give a full flush, they shall respectively discharge 5 litres and 10 litres with variation of  $\pm 0.5$  litres.

The flush pipe shall be of (a) medium quality galvanised iron having internal diameter of  $38 \pm 1$  mm for low level cistern. The flush pipe shall be of suitable length with bends etc. as required for fixing it with front or back inlet W.C. Pan. (b) Polyethylene pipes low density conforming to IS 3076 or high density (c) Unplasticised PVC pipes. For high density polyethylene and unplasticised PVC pipes, the outside diameter of the pipes shall be 40 mm. When PVC plumbing pipes are used the outside diameter of the pipe shall be 40 mm for high level cisterns and 50 mm for low level cisterns.

In case of low level cistern the flush pipe shall be a vertical pipe 30 cm long and having a nominal internal dia  $38 \pm 1$  mm (except plastic flush pipes).

#### **Over Flow Pipe**

- (a) GI overflow pipe shall be of not less than 20 mm nominal bore and shall incorporate a non-corrodible mosquito proof brass cover having 1.25 mm dia perforation, screwed in a manner which will permit it to be readily cleaned or renewed when necessary. No provision shall be made whereby the overflow from the cistern shall discharge directly into the water closet or soil pipe without being detected.

The invert of the overflow pipe in the case of high level and low level cisterns shall be 19 mm minimum above the working water level. In case of overflow due to any reason water should drain out through the over flow pipe and not through the siphon pipe.

- (b) The plastic overflow pipes shall be manufactured from high density polyethylene conforming to IS 4984 or unplasticised P.V.C. conforming to IS 4985.

**Inlet and Overflow Holes:** The cistern shall be provided with inlet and overflow holes, situated one at each end which shall be capable of accommodating an overflow pipe of not less than 20 mm nominal bore and a 15 mm size ball valve. The holes shall be cleanly cast or drilled and the adjacent surfaces shall be smooth.

**17.1.1.2 PVC Cisterns :** Plastic flushing cisterns for WC and Urinals shall be as per IS 7231.

The materials for manufacturing various components of the flushing cisterns shall conform to the requirements given in Table 17.1 below:



**TABLE 17.1**  
**Materials for Various Components of Flushing Cisterns**

| <i>Sl. No.</i> | <i>Component(s)</i>                | <i>Material</i>   | <i>Conforming to</i>                                      |
|----------------|------------------------------------|---|---|
| (1)            | (2)                                | (3)   | (4)   |
| 1.             | Cisterns                           | High density polyethylene (HDPE)<br>Or<br>Polystyrene, high impact<br>Or<br>Polypropylene <sup>1)</sup><br>Or<br>Acrylonitrile-butadiene-styrene (ABS)<br>Or<br>Glass Fibre reinforced plastic (GRP)  | IS 7328<br>IS 2267<br>-<br>-<br>-                         |
| 2.             | Flush pipe                         | Steel tube, seamless or welded, medium or light, completely protected inside and outside by hot-dip galvanizing, electroplating or vitreous enamelling<br>Or<br>Lead pipe<br>Or<br>Copper alloy tube<br>Or<br>High density polyethylene pipe<br>Or<br>Unplasticised PVC plumbing pipe | IS 1239 ((Part 1)<br>IS 404 (Part 1)<br>IS 407<br>IS 2501 |
| 3.             | Cover                              | Same material as that of the body   |   |
| 4.             | Chain                              | Hot-dip galvanized steel wires<br>Or<br>Inter-locked non-ferrous metal<br>Or<br>Any other corrosion resistant material  | -   |
| 5.             | Overflow pipe                      | High density polyethylene<br>Or<br>Unplasticised PVC<br>Or<br>Any other corrosion-resistant material  | IS 4984<br>IS 4985  |
| 6.             | Siphon/Valve                       | High density polyethylene<br>Or<br>Polystyrene, high impact<br>Or<br>Polypropylene<br>Or<br>Acrylonitrile- butadiene-styrene<br>Or<br>Glass fibre reinforced plastic (GRP)  | IS 7328<br>IS 2267<br>-<br>-                              |
| 7.             | Operating Mechanism/ Lever         | Non-ferrous metal or any other corrosion resistant material   | -   |
| 8.             | Float valve                        | Water fittings-Copper Alloy Float Valves (Horizontal Plunger type)<br>Plastic equilibrium float valve for cold water services<br>Diaphragm type (plastic body) float operated valves for cold water services  | IS 1703<br>IS 12234<br>IS 13049                           |
| 9.             | Polyethylene float for float valve | As specified in IS 9762   |   |
| 10.            | Coupling nut and lock-nut          | Non-ferrous metal,<br>Or<br>Hot-dip galvanised steel<br>Or<br>Hot-dip galvanised malleable iron<br>Or   |   |

- (1) Talc as filler, if used shall not exceed 20%

**Note:** Where the requirements for the material of any component or the relevant Indian Standard designation for any material are not specified, these shall be as directed by the Engineer-in-Charge.

The thickness of the body including cover at any point shall not be less than 2 mm for GRP, and not less than 3 mm for other plastic materials. The cistern shall be free from manufacturing faults and other defects affecting its utility. All working parts shall be designed so as to operate smoothly and efficiently. The cistern shall be mosquito-proof. It shall be deemed to be mosquito proof only when there is no clearance anywhere in it which would permit a 1.6 mm diameter wire to pass through. The outlet of each siphon or stand pipe or flush valve shall be securely connected to the cistern by means of a lock nut. In the case of plastic siphon, it shall be provided with suitable means of ensuring and maintaining watertight and airtight joint to the cistern.

The cistern shall be provided with a removable cover which shall fit closely and shall be secured against displacement. In designs, where the operating mechanism is attached to the cover, the cover may be made in two sections, the section supporting the mechanism being securely fixed or booked to the body.

The flush pipe (except plastic flush pipe) shall have an internal diameter of  $32 \pm 1$  mm for high level cistern and  $38 + 1$  mm for low level cistern. The steel flush pipe shall be not less than 1 mm thick whereas the lead flush pipe shall have a minimum thickness of 3.5 mm. For high density polyethylene pipes, the outside diameter of the pipes shall be 40 mm. For unplasticised PVC plumbing pipes the outside diameter of the pipe shall be 40 mm for high level cisterns, and 50 mm for low level cisterns. In the case of high level flushing cisterns, a pipe clip fitted with a rubber buffer shall be fixed to the flush pipe to prevent damage either to the pipe or to the seat when the seat is raised. No flush pipe is required for coupled cisterns.

**Note:** The minimum thickness specified is for normal conditions of service. Where highly corrosive atmospheres are expected, greater thicknesses are required to be provided as per nomenclature of the item.

#### ***Flush Pipe Connection to Cistern***

The flush pipe shall be securely connected to cistern outlet and made airtight by means of a coupling nut. The nuts made of injection-molded HDPE/Polyacetal may be used only if the end pipe is also made of plastic. The nominal internal diameter of the cistern outlet shall be not less than 32 mm and 38 mm for high-level and low-level cisterns respectively.

The screw threads for connection to the flush pipe shall not be less than size  $1\frac{1}{2}$  of IS 2643 (Part 3). In the case of polyethylene and unplasticised PVC flush pipes, the upper end of the flush pipe shall be provided with suitable means of ensuring and maintaining a watertight and airtight joint to the flushing cistern. When ordered for use with a flush pipe, the outlet connection may be supplied with coupling nut made of copper based alloy or other non-corrodible material and a plain tail piece having a minimum length of 60 mm. The centre of the outlet hole shall be generally central to the length of the cistern. The length of the outlet shall be  $37 \pm 2$  mm in case of interchangeable siphon; however, where integral siphon is provided, the outlet length shall be  $20 \pm 2$  mm.

**Note:** The length of the cistern outlet shall be the dimension from the bottom surface of the cistern to the end of the outlet after the cistern with siphon/stand pipe has been duly fitted with all washers, lock-nuts, etc.

### ***Inlet and Overflow Holes***

The cistern shall be provided with inlet and overflow holes, situated one at each end, which shall be capable of accommodating overflow pipe of not less than 20 mm nominal bore and a 15 mm size float valve. The holes shall be cleanly moulded or drilled and the adjacent surfaces shall be smooth.

### ***Float Valve***

The float valve shall be 15 mm nominal size and shall conform to IS 1703 or IS 12234 or IS 13049.

### ***Operating Mechanism Lever***

The operating mechanism/lever shall not project beyond the side of the cistern for a distance greater than 350 mm measured from the centre of the cistern to the end of the lever arm. The lever arm shall be provided with a suitable hole near the end through which a split ring or S-hook can be inserted. A string (chain) shall be attached to the ring or hook. When S-hook is employed, it shall be effectively closed after assembly to prevent accidental disconnection.

In the case of low-level cisterns, where the mechanism is handle operated, the handle, whether situated on the front or at the end of the cistern, shall be within the projection limit. Particular attention shall be given to the case of operation of the handle.

### ***String (Chain)***

The string (chain) shall be of such strength as to sustain a dead load of 500 N without any apparent or permanent deformation.

The string (chain) shall terminate in a suitable handle or pull made of a moulding in any heat-resisting and non-absorbent plastic or any other equally suitable material. The finish shall be smooth and all burrs which are liable to cause injury to the hand when gripped shall be removed.

### ***Overflow Pipe***

The overflow pipe shall be of not less than 20 mm nominal bore and shall incorporate a non-corrodible mosquito-proof device secured in a manner which will permit it to be readily cleaned or renewed when necessary. No provision shall be made whereby the overflow from the cistern shall discharge directly into the water-closet or soil pipe without being detected.

The invert of the overflow pipe in the case of high-level and low level cisterns and the top edge of the overflow pipe in the case of coupled cistern shall be 19 mm (Min) above the working water level. In case of overflow due to any reason, water should drain out through the overflow pipe and not through the siphon pipe.

### ***Finish***

The surface of the cistern including cover shall be free from blisters and delamination, and reasonably free from flow lines, streaking or colour variations. The cistern and cover shall be opaque to light.

### ***Operational and Performance Requirements***

#### ***Flushing Arrangement***

The cistern under working conditions and with the float valve in closed position shall operate on a single operation of the operating mechanism/lever without calling for a sudden jerk in pulling. If a valve is used instead of siphon for flushing purposes, the valve shall be completely leak proof.

#### ***Working Water Level***

The working water-level shall be a minimum of 6.5 cm. below the effective top edge of the cistern and shall be legibly and permanently marked on the inside of the cistern. Effective top edge shall be taken on edge after top of the body without considering bead.

#### *Freedom from Self Siphonage*

The siphonic system shall be capable of being rapidly brought into action when the water is at the working water level, but shall not self siphon or leak into the flush pipe when the water is up to 1 cm above the invert of the overflow pipe.

#### *Reduced Water Level*

The discharge shall operate satisfactorily when the cistern is filled to a level up to 1 cm. below the working water level.

#### *Discharge Capacity*

When tested in accordance with IS 7231, cistern of 5 litres and 10 litres capacities, when required to give a full flush, shall respectively discharge 5 litres and 10 litres with variation of  $\pm 0.5$  litres. Dual-flush cistern of 10 litres capacity shall discharge alternatively a short flush of  $5 \pm 0.5$  litres. Dual flush cistern of 6/3 litres capacity shall discharge  $6 \pm 0.5$  litres and alternatively a half flush of  $3 \pm 0.5$  litres.

#### *Discharge Rate*

When tested in accordance with IS 7231, the discharge rate shall be  $10 \pm 0.5$  litres within 6 seconds and  $5 \pm 0.5$  litres within 3 seconds for cistern of capacities 10 litres and 5 litres and  $6 \pm 0.5$  litres within 6 second and  $3 \pm 0.5$  litres within 3 second for cistern of 6/3 litres capacity respectively. The cistern shall be so designed that there is no appreciable variation in the force of the flush during the discharge of the required quantity of water. For coupled cisterns, this test shall not be applicable.

### **Special Requirements**

#### *Distortion Resistance Test*

The cisterns, complete with its fittings, shall be installed and filled with water to the marked water line and observed for any distortion. The cistern shall not budge more than 6 mm and the cover shall not be dislodged.

#### *Dead Load Test*

When the flushing mechanism incorporates chain pull or hand operated lever, the cistern, complete with its fittings, when installed and filled with water to the marked water line and tested by the application of a dead load of 230 N applied 6 mm from the end of the operating lever arm for 30 seconds, shall not distort to such an extent that any part becomes detached. In the case of other operating mechanism, the dead load applied shall be a mass equivalent to the operating force required to overcome the normal hydrostatic head; Thirty seconds after the load is removed, the function and appearance of the cistern shall not be impaired.

#### *Front Thrust Test*

The front thrust test shall be applied only to cisterns intended for low level use. The cistern complete with its fittings, when installed and filled with water to the marked water line and tested by the method described in IS 7231, shall not distort to such an extent as to be inoperable or unsightly when the load is removed.

#### *Impact Test*

The cistern, complete with its fittings, when installed and filled as described in IS 7231 shall show no defect after one impact. Repeat the test but with the cistern empty. The cistern shall show no defect after the further impact.

### **17.1.2 Draining Board**

Draining board made of Glazed fireclay conforming to C.P.W.D. Specifications and as per directions of Engineer-in-Charge, shall be provided. The size of the board shall be as specified. The entire surface including bottom of the board shall be finished smooth.

### 17.1.3 Foot Rests (Fig. 17.4)

Foot rests shall be of Vitreous China conforming to IS 2556 (Part- X). Foot rests which are rectangular shall meet the minimum requirements and dimensions shown in Fig. 17.4 and may be of different designs where so specified. Foot rests of different shapes and sizes shall also be allowed subject to approval of Engineer-in-Charge.

### 17.1.4 Glass Shelf/PVC Shelf

Glass shelf shall consist of an assembly of glass shelf, with anodised aluminium angle frame to support the glass shelf. The shelf shall be of glass of best quality with edges rounded off, and shall be free from flaws specks or bubbles. The size of the shelf shall be 60 x 12 cm unless otherwise specified and thickness not less than 5.5 mm. The shelf shall have C.P. brass brackets which shall be fixed with C.P. brass screws to rawl plugs firmly embedded in the walls.

PVC shelf as per manufacturer's specifications and size as specified shall be provided.

### 17.1.5 Mirror

The mirror shall be of superior glass with edges rounded off or beveled, as specified. It shall be free from flaws, specks or bubbles. The size of the mirror shall be 60 x 45 cm unless specified otherwise and its thickness shall not be less than 5.5 mm. It shall be uniformly silver plated at the back and shall be free from silvering defects. Silvering shall have a protective uniform covering of red lead paint. Where beveled edge mirrors of 5.5 mm thickness are not available, fancy looking mirrors with PVC beading/border or aluminium beading or stainless steel beading/border based on manufacture's specifications be provided nothing extra shall be paid on this account. Backing of mirrors shall be provided with environmentally friendly material other than asbestos cement sheet.

### 17.1.6 M.S. Stays and Clamps (Fig. 17.5)

The clamps shall be made from 1.5 mm thick M.S. flat of 32 mm width, bent to the required shape and size to fit tightly on the socket, when tightened with nuts & bolts. It shall be formed of two semicircular pieces with flanged ends on both sides with holes to fit in the screws, bolts and nuts 40 mm long. The stay shall be minimum one metre long of 10 mm dia M.S. bar. One end of the stay shall be bent for embedding in the wall in cement concrete block of size 20 x 10 x 10 cm in 1:2:4 mix (1 cement : 2 coarse sand : 4 graded stone aggregate 20 mm nominal size). The concrete shall be finished to match with the surrounding surface.

### 17.1.7 Pillar Taps

Pillar taps shall be chromium plated brass and shall conform to IS 1795. The nominal sizes of the pillar tap shall be 15 mm or 20 mm as specified. The nominal size shall be designated by the nominal bore of the pipe outlet to which the tap is to be fitted. Finished weights of 15 mm and 20 mm pillar taps shall be as prescribed in Table 17.2.

**TABLE 17.2**  
**Minimum Finished Weights of Pillar Taps**

| <i>Particulars</i>       | <i>Weights in gms</i> |                   |
|--------------------------|-----------------------|-------------------|
|                          | <i>15 mm size</i>     | <i>20 mm size</i> |
| Body                     | 255                   | 505               |
| Washer plate loose valve | 15                    | 28                |
| Back nut                 | 40                    | 50                |
| Tap                      | 650                   | 1175              |

Casting shall be sound and free from laps, blow hole and pitting. External and internal surfaces shall be clean, smooth and free from sand and be neatly dressed. The body, bonnet and other parts shall be machined true so that when assembled, the parts shall be axial, parallel and cylindrical with surfaces smoothly finished.

The area of waterway through the body shall not be less than the area of the circle of diameter equal to the bore of the seating of the tap. The seating of pillar tap shall be integral with the body and edges rounded to avoid cutting of washer. Pillar taps shall be nickel chromium plated and thickness of coating shall not be less than service grade No. 2 of IS 4827 and plating shall be capable of taking high polish which shall not easily tarnish or scale.

Every pillar tap, complete with its component parts shall withstand an internally applied hydraulic pressure of 20 Kg/sq. cm maintained for a period of 2 minutes during which period it shall neither leak nor sweat.

#### **17.1.8 Sand Cast Iron or Centrifugally Cast (Spun) Iron Pipes and Fittings**

Sand cast iron spigot and socket soil, waste and ventilating pipes, fittings and accessories shall conform to IS 1729. Centrifugally cast (Spun) iron spigot and socket soil, waste and ventilating pipes, fittings and accessories shall conform to IS 3989.

The fittings shall conform to the same I.S. specifications to which the pipe itself conforms in which they are connected.

The pipes shall have spigot and socket ends, with head on spigot end in case of sand cast iron pipes and without head on spigot end in case of cast iron (Spun) pipes. The pipes and fittings shall be true to shape, smooth and cylindrical, their inner and outer surface being as nearly as practicable concentric. They shall be sound and shall be free from cracks, taps, pinholes and other imperfections and shall be neatly dressed and carefully fettled. All pipes and fittings shall ring clearly when struck with a light hand hammer.

The ends of pipes and fittings shall be reasonably square to their axis. The sand cast iron pipes shall be 1.5/1.8/2.0 metre in length including socket ends, cast iron (Spun) pipes shall be 1.5/1.75/2.0/2.5/3.0 metre in length excluding socket ends, unless shorter lengths are either specified or required at junctions etc. The pipe and fittings shall be supplied without ears, unless specified or directed otherwise.

All pipes and fittings shall be coated internally and externally with the same material at the factory, the fitting being preheated prior to total immersion in a bath containing a uniformly heated composition having a tar or other suitable base. The coating material shall have good adherence and shall not scale off. In all instances where the coating material has tar or similar base it shall be smooth and tenacious and hard enough not to flow when exposed to a temperature of 77 degree centigrade but not so brittle at a temperature of 0 degree centigrade as to chip off when scribed lightly with a pen knife.

The standard weights and thicknesses of pipes and their tolerances shall be as prescribed in Appendix A.

The thickness of fittings and their socket and spigot dimensions shall conform to the thickness and dimensions specified for the corresponding sizes of straight pipes. The tolerance in weights & thicknesses shall be the same as for straight pipes.

The access door fittings shall be designed so as to avoid dead spaces in which filth may accumulate. Doors shall be provided with 3 mm rubber insertion packing and when closed and bolted, these shall be water tight.

### **Sand Cast Iron Floor Trap or Nahani Trap**

Sand cast Iron Floor trap or Nahani trap shall be 'P' or 'S' type with minimum 50 mm seal. However, if the plumbing is in two pipe system and with a gully trap at the ground level the minimum water seal shall be 35 mm. The traps shall be of self cleansing design and shall have exit of same size as that of waste pipe. These shall conform to IS 1729.

### **17.1.8A HUBLESS CENTRIFUGALLY CAST (SPUN) IRON PIPES AND FITTINGS**

Hubless Centrifugally Cast (Spun) Iron Pipes and Fittings soil, waste and ventilating pipes, fittings and accessories shall conform to IS 15905.

The hubless centrifugally cast (spun) iron pipes shall have plain both ends (spigot type), without sockets. The pipes and fittings shall be true to shape, smooth and cylindrical, their inner and outer surface being as nearly as practicable concentric. They shall be sound and shall be free from cracks, taps, pinholes and other imperfections and shall be neatly dressed and carefully fettled. All pipes and fittings shall emit a clear ringing sound when struck with a light hand hammer.

The ends of pipes and fittings shall be reasonably square to their axis. The hubless centrifugally cast iron pipes shall be 3.0 metre or more in length.

All pipes and fittings shall be coated internally and externally with the epoxy coating material at the factory, the fitting being preheated prior to total immersion in a bath containing a uniformly heated composition. The coating material shall have good adherence and shall not scale off.

The tolerance in diameter of pipes shall be as prescribed in Table-17.2A below :

**Table-17.2A**  
**External Diameters and Tolerances**

| <b>Sl. No.</b> | <b>Nominal size<br/>DN (in mm)</b> | <b>External Diameter<br/>DE (in mm)</b> | <b>Tolerance on External diameter<br/>DE<br/>(in mm)</b> |
|----------------|------------------------------------|---|--|
| (1)            | (2)                                | (3)                                     | (4)  |
| 1              | 50                                 | 58                                      | +2<br>-1   |
| 2              | 75                                 | 83                                      | +2<br>-1   |
| 3              | 100                                | 110                                     | +2<br>-2   |
| 4              | 150                                | 160                                     | +2<br>-2   |
| 5              | 200                                | 210                                     | +2.5<br>-2.5   |

The thickness of fittings and spigot dimensions shall conform to the thickness and dimensions specified for the corresponding sizes of straight pipes. The nominal & minimum thicknesses of pipes & fittings shall be as per Table-2 below:



**Table-2**  
**Nominal & Minimum Thickness of Pipes & Fittings**

| Sl. No. | Nominal size (DN) | Thickness 'e' mm |         |          |         |
|---------|-------------------|------------------|---------|----------|---------|
|         |                   | Pipe             |         | Fittings |         |
|         |                   | Nominal          | Minimum | Nominal  | Minimum |
| (1)     | (2)               | (3)              | (4)     | (5)      | (6)     |
| i)      | 50                | 3.5              | 3.0     | 4.2      | 3.0     |
| ii)     | 75                | 3.5              | 3.0     | 4.2      | 3.0     |
| iii)    | 100               | 3.5              | 3.0     | 4.2      | 3.0     |
| iv)     | 150               | 4.0              | 3.5     | 5.3      | 3.5     |
| v)      | 200               | 5.0              | 4.0     | 6.0      | 4.0     |

The access door fittings shall have no dead spaces in which filth may accumulate. Doors shall be provided with 3 mm rubber insertion packing and when closed and bolted, these shall be water tight.

**Joints:**

The pipes and fittings may assembled using various types of joints, The joints are intrinsic components of the drainage, whose characteristics and tolerances shall be specified in the manufactures catalogues.

Taking into account the different applications of cast iron pipe work systems, various joint designs are permitted provided that they satisfy the requirement to this standard. The joints shall incorporate one or more EPDM rubber gasket(s) to ensure leak tightness and prevent direct contact between the ends of pipes, fittings and accessories.

Materials for coupling of clamping components shall usually be made from:

- (a) Ductile iron of grade 500/7 as per IS 1865,  
or
- (b) Stainless steels in accordance with IS 1570 (Part 5) in order to ensure resistance to corrosion and a stabilization against the austenitic stainless steel with at least 17 percent chrome and 9 percent nickel of equivalent, or from material of comparable resistance.
- (c) Ductile iron couplings of clamping components shall be coated internally and externally.
- (d) All parts of the joints shall free from defects likely to compromise their suitability for use.

**17.1.9 Plastic Seat and Covers for Water Closet (Fig. 17.6)**

The seat and cover shall be of thermosetting or thermoplastic conforming to IS 2548 (Part-1) or of thermoplastic confirming to IS 2548 (Part-2) as specified. Unless otherwise specified these shall be of closed pattern.

**17.1.9.1** Thermosetting plastic used shall conform to grade 2 or 3 of IS 1300 when it is phenolic plastic or IS 3389 when of urea formaldehyde.

Thermo plastic materials used may be of Polystyrene conforming to type 2 or 3 of IS 2267 or of polypropylene, Appendix A of IS 2548. In public buildings where rough and heavy use of seats and covers are common, plastic seats shall be moulded out of thermosetting materials, phenolic or urea formaldehyde only and the underside of the seat shall be flat with solid moulding.

**17.1.9.2** The hinging device shall be bronze or brass with nickel chromium plating confirming to IS 1068 and the seat shall have not less than three rubber or plastic buffers of size 25 mm x 40 mm x 10 mm for closed front seats and not less than four for open front seats, which shall be securely fixed to the underside of the seat unless otherwise specified. The cover shall be fitted with the same number of buffers as provided for the seat.



**17.1.9.3** Seats shall have a smooth finish and shall be non absorptive and free from cracks and crevices. They shall be capable of being easily cleaned and shall not be adversely affected by common solvents or household cleanser.

**17.1.9.4 Strength:** The seats shall withstand without permanent distortion of the seat or hinge fittings or damage to any finish, a load of 1150 N for 30 minutes applied in the manner prescribed in IS 2548.

#### **17.1.10 Sinks (Fig. 17.7)**

Laboratory sinks and Kitchen sinks shall be of white glazed fire clay conforming to IS 771 (Part-2) with up to date amendments. The kitchen sink shall be of one piece construction with or without rim but without overflow.

**17.1.10.1** Stainless steel kitchen sink shall be of sizes as specified and shall be conforming to IS 13983 (Fig. 17.7).

#### **17.1.11 Towel Rail**

The towel rail shall be of PTMT as specified and as per direction of Engineer-in-charge.

#### **17.1.12 Toilet Paper Holder**

The toilet paper holder shall be of CP brass or vitreous china as specified and of size and design as approved by the Engineer-in-Charge. It shall be fixed in position by means of C.P. brass screws and rawl plugs embedded in the wall.

#### **17.1.13 Urinals**

**17.1.13.1 Bowl Type Urinals (Fig. 17.9 & 17.10) :** Urinal basins shall be of flat back or corner wall type lipped in front. These shall be of white vitreous china conforming to IS 2556-(Part 6). The urinals shall of one piece construction. Each urinal shall be provided with not less than two fixing holes of minimum dia 6.5 mm on each side. Each urinal shall have an integral flushing rim of suitable type and inlet or supply horn for connecting the flush pipe. The flushing rim and inlet shall be of the self draining type. It shall have a weep hole at the flushing inlet of the urinals.

At the bottom of the urinal an outlet horn for connecting to an outlet pipe shall be provided. The exterior of the outlet horn shall not be glazed and the surface shall be provided with grooves at right angles to the axis of the outlet to facilitate fixing to the outlet pipe. The inside surface of the urinal shall be uniform and smooth throughout to ensure efficient flushing. The bottom of pan shall have sufficient slope from the front towards the outlet such that there is efficient draining.

**17.1.13.2 Half Stall Urinals (Fig. 17.11) :** They shall be of white vitreous China conforming to IS 2556 (Part 6). They shall be of one piece construction with or without an integral flushing box rim and provided with slots or alternative fixing arrangement at the flat back end. They shall be provided with ridges where integral flushing rim is not provided in the sides of the interior of the bowl, to divert the water towards the front line of the urinal where integral flushing box rim is specified, water spreaders provided shall conform to IS 2556 Part-6 (Fig. 17.13) . These shall be vitreous China of one piece construction with integral flush inlet. The tolerance of  $\pm 4$  per cent may be allowed on the dimensions specified.

**17.1.13.3 Urinal Partition Slabs :** Urinal Partition slabs shall be provided, as specified in the item of work.

**17.1.13.4 Squatting Plate Urinal (Fig. 17.12) :** The plates shall be of white vitreous china conforming to IS 2556 (Part-1) and IS 2556 (Part-6) with internal flushing rim with front or side inlet. Squatting Plate shall be of one piece construction. Each urinal shall have integral longitudinal flushing pipe of suitable type which may be connected to flush pipe. These shall be 100 mm dia white glazed vitreous china channel with stop and outlet piece in front.

**17.1.14 Wash Basins (Fig. 17.14, 17.15, 17.16, 17.17 & 17.18)**

Wash basins shall be of white vitreous china conforming to IS 2556 (Part -I) and IS 2556 (Part-4). Wash basins either of flat back or angle back as specified shall be of one piece construction, including a combined overflow. All internal angles shall be designed so as to facilitate cleaning. Each basin shall have a rim on all sides, except sides in contact with the walls and shall have a skirting at the back. Basins shall be provided with single or double tap holes as specified. The tap holes shall be 28 mm square or 30 mm round or 25 mm round for pop up hole. A suitable tap hole button shall be supplied if one tap hole is not required in installation. Each basin shall have circular waste hole to which the interior of basin shall drain. The waste hole shall be either rebated or beveled internally with dia meter of 65 mm at top. Each basin shall be provided with a non-ferrous 32 mm waste fitting. Stud slots to receive the brackets on the underside of the wash basin shall be suitable for a bracket with stud not exceeding 13 mm diameter, 5 mm high and 305 mm from the back of basin to the centre of the stud. The stud slots shall be of depth sufficient to take 5 mm stud. Every basin shall have an integral soap holder recess or recesses, which shall fully drain into the bowl. A slot type of overflow having an area of not less than 5 sq. cm, shall be provided and shall be so designed as to facilitate cleaning of the overflow.

Where oval shape or round shape wash basins are required to be fixed these shall be fixed preferably in RCC platform with local available stone topping either fully sunk in stone top or top flush with the stone topping as directed by Engineer-in-Charge.

The wash basins shall be one of the following patterns and sizes as specified (Fig. 17.14).

- (a) Flat back:        660 x 460 mm (Surgeon's Basin)  
                             630 x 450 mm  
                             550 x 400 mm  
  
                             450 x 300 mm

- (b) Angle back: 600 x 480 mm 400 x 400 mm

White glazed pedestals for wash basins, where specified shall be provided. The quality of the glazing of the pedestal shall be exactly the same as that of the basin along with which it is to be installed. It shall be completely recessed at the back to accommodate supply and waste pipes and fittings. It shall be capable of supporting the basin rigidly and adequately and shall be so designed as to make the height from the floor to top of the rim of basin 75 to 80 cm as shown in Fig. 17.14, 17.15, 17.16, 17.17 & 17.18. All the waste fittings shall be brass chromium plated, or as specified.

**17.1.15 Waste Fittings for Wash Basins and Sinks (Fig. 17.8)**

The waste fittings shall be of nickel chromium plated brass, with thickness of plating not less than service grade 2 of IS 4827 which is capable of receiving polish and will not easily scale off. The fitting shall conform in all respect to IS 2963 and shall be sound, free from laps, blow holes and fittings and other manufacturing defects. External and internal surfaces shall be clean and smooth. They shall be neatly dressed and be truly machined so that the nut smoothly moves on the body.

Waste fitting for wash basins shall be of nominal size of 32 mm. Waste fittings for sinks shall be of nominal size 50 mm.

### **17.1.16 Water Closet (Fig. 17.19, 17.20, 17.21, 17.22 & 17.23)**

**17.1.16.1 Squatting Pans (Indian Type W.C.) (Fig. 17.19, 17.20 & 17.21) :** Squatting pans shall be of white vitreous china conforming to IS 2556 Part-I for General Requirements and relevant IS codes for each pattern as described below:

- (i) Long pattern-conforming to IS 2556 (Part-3).
- (ii) Orissa pattern-conforming to IS 2556 (Part-3).
- (iii) Integrated type conforming to IS 2556 (Part-14).

Preferably Orissa type pan should be used.

Each pan shall have an integral flushing rim of suitable type. It shall also have an inlet or supply horn for connecting the flush pipes, as shown in Fig. 17.19, 17.20 & 17.21. The flushing rim and inlet shall be of the self draining type. It shall have weep hole at the flushing inlet to the pan. The flushing inlet shall be in the front, unless otherwise specified or ordered by the Engineer-in-Charge. The inside of the bottom of the pan shall have sufficient slope from the front towards the outlet and the surface shall be uniform and smooth to enable easy and quick disposal while flushing. The exterior surface of the outlet below the flange shall be an unglazed surface which shall have grooves at right angles to the axis of the outlet. In all cases a pan shall be provided with a (100 mm) S.C.I. trap 'P' or 'S' type with approximately 50 mm water seal and 50 mm dia vent horn, where required by the Engineer-in-Charge.

**17.1.16.2 Wash Down Type (European Type W.C.) (Fig. 17.22 & 17.23) :** Water closets shall be of white vitreous china conforming to IS 2556 (Part-1) and 2556 (Part-2), as specified and shall be of "Wash down type". The closets shall be either of the two patterns (Pattern I & Pattern II) and sizes as shown in Fig. 17.22 & 17.23 as specified. The closets shall be of one piece construction. Each water closet shall have not less than two holes having a minimum diameter of 6.5 mm for fixing to floor and shall have an integral flushing rim of suitable type. It shall also have an inlet or supply horn for connecting the flushing pipe of dimensions as shown in table in Fig. 17.20 & 17.21 the flushing rim may be boxed or open type. In the case of box rims adequate number of holes, on each side together with a slot opposite the inlet shall be provided. The flushing rim and inlet shall be of the self draining type. The water closet shall have a weep hole at the flushing inlet. Each water closet shall have an integral trap with either 'S' or 'P' outlet with at least 50 mm water seal. For P trap, the slope of the outlet shall be 14 deg. below the horizontal. Where required the water closet shall have an antisiphonage 50 mm dia vent horn on the outlet side of the trap with dimension conforming to those given in Fig. 17.22 and on either right or left hand or centre as specified set at an angle of 45 deg. and invert of vent hole not below the central line of the outlet. The inside surface of water closets and traps shall be uniform and smooth in order to enable an efficient flush. The serrated part of the outlet shall not be glazed externally. The water closet, when sealed at the bottom of the trap in line with the back plate, shall be capable of holding not less than 15 litres of water between the normal water level and the highest possible water level of the water closet as installed.

## **17.2 GENERAL REQUIREMENTS FOR INSTALLATION OF W.C. PAN**

**17.2.1** The work shall be carried out, complying in all respects with the requirements of relevant by-laws of the local body in whose jurisdiction the work is situated.

**17.2.2** Any damage caused to the building, or to electric, sanitary, water supply or other, installations etc. therein, either due to negligence on the part of the contractor, or due to actual requirements of the work, shall be made good and the building or the installation shall be restored to its original condition by the contractor. Nothing extra shall be paid for such restoration works except where otherwise specified.

**17.2.3** For making good the damage to the under mentioned items of work, the specifications as given in the following paras shall apply, unless directed otherwise.

- (a) **Masonry Work:** The masonry work shall be made good by using the same class of bricks, tiles or stones as was damaged during the execution of the work. The mortar used shall be cement mortar 1:5 (1 cement: 5 fine sand) or as directed by the Engineer-in-Charge.
- (b) **Plain Concrete Work :** Concrete work for sub-grade of the flooring, foundations and other plain concrete works shall be cement concrete 1:5:10 (1 cement : 5 coarse sand : 10 graded stone aggregate 40 mm nominal size). A coat of neat cement slurry shall be applied at the junction with old work, before laying fresh concrete.
- (c) **Cement Concrete Flooring and R.C.C. Work :** Cement concrete 1:2:4 (1 Cement : 2 Coarse sand : 4 graded stone aggregate 20 mm nominal size) shall be used after applying a coat of neat cement slurry at the junction with old work, and the surface finished to match with the surrounding surface.
- (d) **Plastering:** Cement plaster 1:4 (1 cement: 4 sand) shall be used. The sand shall be fine or coarse, as used in the original work. The surface shall be finished with two or more coats of white wash, colour wash, distemper or painting as required, but where the surface is not to be white washed, colour washed, distempered or painted, it shall be finished as required to match with the surrounding surface.
- (e) **Other Items:** Damage to any other item shall be made good as directed by the Engineer-in-Charge.

**Note:** In all the above operations the damaged portion shall be cut in regular geometric shape and cleaned before making good the same.

**17.2.4** All exposed G.I., C.I. or lead pipes and fittings shall be painted with approved quality of paint and shade as specified. The painting work shall conform to specification described under SH: Painting.

**17.2.5** All sanitary and plumbing work shall be carried out through licensed plumbers.

**17. 2.6** On completion of the work the site shall be cleaned and all rubbish disposed off as directed by the Engineer-in-Charge.

**17.2.7** Various sanitary fittings described under 17.1 including fixing shall be enumerated individually or in combination under relevant items of works as described below. When used in combination, specifications as described under relevant paras shall apply but nothing extra shall be paid for making connections required for successful functioning of the combination.

### **17.3 INSTALLATION OF DRAINING BOARD**

#### **17.3.1 Fixing**

One end of the board shall rest on sink and the other end shall be supported on C.I. bracket embedded in cement concrete (1:2:4) block 100 × 75 × 150 mm. The brackets used shall be of cantilever type or wall fixed type as for the sink.

#### **17.3.2 Painting**

The brackets shall be painted with two or more coats of approved paint.

#### **17.3.3 Measurements**

Draining board shall be measured in numbers.

#### **17.3.4 Rate**

The rate shall include the cost of all materials and labour involved in all operations.

## **17.4 INSTALLATIONS OF FLUSHING CISTERN**

### **17.4.1 Fixing**

**17.4.1.1 Low Level Cistern:** The cistern shall be fixed on C.I. cantilever brackets which shall be firmly embedded in the wall in cement concrete (1:2:4) block 100 x 75 x 150 mm. Connection between cistern and closet shall be made by means of 40 mm dia flush bend with rubber or G.I. inlet connection as specified.

**17.4.1.2 Automatic Cistern:** Clause 17.4.1.1 shall apply except that CP Brass stop cock shall be provided for cistern having a capacity of more than 5 liter. The main & distribution flush pipe shall be fixed to the wall by means of standard pattern holder bat clamp shown in Fig. 17.5.

### **17.4.2 Painting**

The brackets shall be painted, if specified, with two or more coats of paint of approved shade and quality.

### **17.4.3 Measurements**

Cistern, including all fittings, shall be measured in numbers.

### **17.4.4 Rate**

The rate shall include the cost of all materials and labour involved in all the operations described above.

## **17.5 INSTALLATION OF MIRROR**

### **17.5.1 Fixing**

The mirror shall be mounted on backing with environmentally friendly material other than asbestos cement sheet shall be fixed in position by means of 4 C.P. brass screws and C.P. brass washers, over rubber washers and wooden plugs firmly embedded in walls. C.P. brass clamps with C.P. brass screws may be an alternative method of fixing, where so directed. Unless specified otherwise the longer side shall be fixed horizontally.

### **17.5.2 Measurements**

Mirror shall be measured in numbers.

### **17.5.3 Rate**

Rate shall include the cost of all the materials and labour involved in all the operations described above.

## **17.6 FIXING AND JOINTING OF PIPES AND FITTINGS**

**17.6.0** The specifications described in sub-head 12.0 shall apply, as far as applicable, except that the joint shall be lead caulked. All soil pipes shall be carried up above the roof and shall have sand cast iron terminal guard.

### **17.6.1 Height of Ventilating Pipes**

The ventilating pipe or shaft shall be carried to a height of at least 60 cms above the outer covering of the roof of the building or in the case of a window in a gable wall or a dormer window it shall be carried up to the ridge of the roof or at least 2 metres above the top of the window. In the case of a flat roof to which access for use is provided it shall be carried up to a height of 2 metres above the roof and shall not terminate within 2 metres, measured vertically from the top of any window opening which may exist up to a horizontal distance of 3 meters from the vent pipe into such building and in no case shall be carried to a height less than 3 metres above plinth level. In case the adjoining building is taller, the ventilating pipe shall be carried higher than the roof of the adjoining building, wherever it is possible.

The pipes above the parapet shall be secured to the wall by means of M.S. stay and clamps as specified in 17.1.6.

The connections between the main pipe and branch pipes shall be made by using branches and bends with access doors for cleaning. The waste from lavatories, kitchen, basins, sinks, baths and other floor traps shall be separately connected to respective waste stack of upper floors. The waste stack of lavatories shall be connected directly to manhole while the waste stack of others shall separately discharge over gully trap. Where single stack system is provided, the connection shall be made direct to the manhole.

### **17.6.2 Jointing**

The interior of the socket and exterior of the spigots shall be thoroughly cleaned and dried. The spigot end shall be inserted into the socket right up to the back of the socket and carefully centered by two or three laps of treated spun yarn, twisted into ropes of uniform thickness, well caulked into the back of the socket. No piece of yarn shall be shorter than the circumference of the pipe. The jointed pipe line shall be at required levels and alignment.

The leading of pipes shall be made by means of ropes covered with clay or by using special leading rings. The lead shall be melted so as to be thoroughly fluid and each joint shall be filled in one pouring.

The following precautions shall be taken for melting lead:

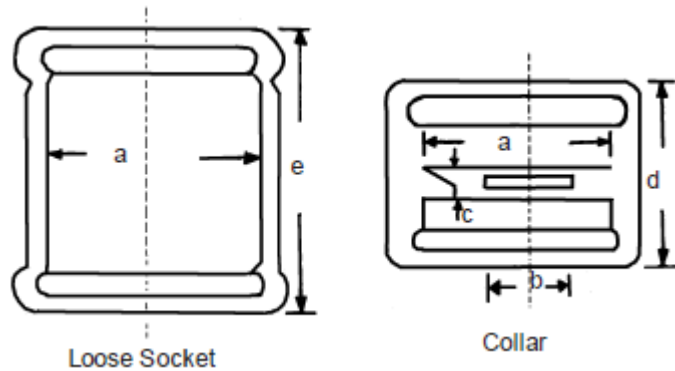
- (a) The pot and the ladle in which lead shall be put shall be clean and dry.
- (b) Sufficient quantity of lead shall be melted.
- (c) Any scum or dross which may appear on the surface of the lead during melting shall be skimmed off.
- (d) Lead shall not be overheated.

After the lead has been run into the joint the lead shall be thoroughly caulked. Caulking of joints shall be done after a convenient length of the pipes has been laid and leaded.

The leading ring shall first be removed and any lead outside the socket shall be removed with a flat chisel and then the joint caulked round three times with caulking tools of increasing thickness and hammer 2 to 3 kg. weight. The joints shall not be covered till the pipe line has been tested under pressure.

Use of collars for jointing is not permitted in any concealed or embedded location. However, in exposed locations where full length pipes cannot be fixed due to site constraints, collars (and not loose sockets) may be used subject to the following:

- (a) No two consecutive joint shall be with the use of collars.
- (b) The joint of collar with the cut/spigot end of the pipe shall be made on the ground in advance and tested against leakage before fixing.
- (c) Cut/spigot end of the pipes shall be inserted in the collars up to the projection inside the collar and jointing shall be done as in the case of socket and spigot joint. The jointed pipe line shall be at required level/slope and alignment.



| As marked in fig | Pipe dia (size in mm) |     |     |     |
|------------------|-----------------------|-----|-----|-----|
|                  | 50                    | 75  | 100 | 150 |
| a                | 76                    | 101 | 129 | 181 |
| b                | 50                    | 75  | 100 | 150 |
| c                | 10                    | 10  | 10  | 10  |
| d                | 79                    | 89  | 95  | 108 |
| e                | 89                    | 101 | 114 | 140 |

**Note:** The dimensions of loose sockets shall correspond to those of appropriate nominal size of pipe.

### 17.6.3 Testing

In order to ensure that adequate lead is poured properly into the joints and to control waste in use of lead, at the beginning of work three or four sample joints shall be made and the quantum of lead per joint approved by the Engineer-in-Charge. All sand cast iron/cast iron (Spun) pipes and fittings including joint shall be tested by smoke test to the satisfaction of the Engineer-in-Charge and left in working order after completion. The smoke test shall be carried out as under:

Smoke shall be pumped into the pipes at the lowest end from a smoke machine which consists of a bellow and burner. The material usually burnt is greasy cotton waste which gives out a clear pungent smoke which is easily detectable by sight as well as by smell, if there is leak at any point of the drain.

### 17.6.4 Painting

All sand cast iron/cast iron (Spun) pipes and fittings shall be painted with shade to match the colour of the background as directed by the Engineer-in-Charge.

### 17.6.5 Measurements

**17.6.5.1** The pipes shall be measured net when fixed in position excluding all fittings along its length, correct to a cm.

**17.6.5.2** When collars are used for jointing SCI pipes these shall be measured as fittings and shall be paid for separately.

**17.6.5.3** No allowance shall be made for the portions of the pipe lengths entering the sockets of the adjacent pipes or fittings. The above shall apply to both cases i.e. whether the pipes are fixed on wall face or embedded in masonry.

**17.6.5.4** No deduction shall be made in the former case from the masonry measurement for the volume of concrete blocks embedded therein. Similarly no deduction shall be made for the volume occupied by the pipes from the masonry when the former are embedded in the later.



### **17.6.6 Rates**

The rate shall include the cost of all labour and materials involved in all the operations described above, excluding fittings, lead caulk jointing, the supply and fixing M.S. holder bat clamps and M.S. stays and clamps, floor trap and painting, which shall be paid for separately.

## **17.7 INSTALLATION OF SEAT AND COVER TO WATER CLOSET**

### **17.7.1 Fixing**

The seat shall be fixed to the pan by means of two corrosion resistant hinge bolts with a minimum length of shank of 65 mm and threaded to within 25 mm of the flange supplied by the manufacturer along with the seat. Each bolt shall be provided with two suitably shaped washers of rubber or other similar materials for adjusting the level of the seat while fixing it to the pans. In addition, one non-ferrous or stainless steel washer shall be provided with each bolt. The maximum external diameter of the washer fixed on the underside of the pan shall not be greater than 25 mm. Alternative hinging devices as supplied by the manufacturer of the seat can also be used for fixing with the approval of Engineer-in-Charge.

### **17.7.2 Measurements**

Seat with cover shall be measured in numbers.

### **17.7.3 Rate**

Rate shall include the cost of all the materials and labour involved in all the operations described above.

## **17.8 INSTALLATION OF SINK**

**17.8.0** The installation shall consist of assembly of sink C.I. brackets, union and G.I. or P.V.C. waste pipe.

### **17.8.1 Fixing**

The sink shall be supported on C.I. cantilever brackets, embedded in cement concrete (1:2:4) block of size 100 x 75 x 150 mm. Brackets shall be fixed in position before the dado work is done. The C.P. brass or P.V.C. union shall be connected to 40 mm nominal bore G.I. or PVC waste pipe which shall be suitably bent towards the wall and shall discharge into a floor trap. C.P. brass trap and union and waste shall be paid separately. The height of front edge of sink from the floor level shall be 80 cm.

### **17.8.2 Measurements**

The sinks shall be measured in numbers.

### **17.8.3 Rate**

Rate shall include the cost of all materials and labour involved in all the operations described above but shall not included the cost of waste fitting and brackets which shall be paid for separately.

## **17.9 INSTALLATION OF URINAL LIPPED, HALF STALL (SINGLE OR RANGE) (FIG. 17.9 & 17.11)**

**17.9.0** Urinal installation shall consist of a lipped urinal (Single or range), an automatic flushing cistern, G.I. flush and waste pipe. The capacity of flushing cistern and relevant size of flush pipe for urinals in a range shall be as prescribed in Table 17.3.

Waste pipe shall be of 32 mm nominal bore G.I. pipe and shall be paid separately.

### **17.9.1 Fixing**

Urinals shall be fixed in position by using wooden plugs and screws. It shall be at a height of 65 cm from the standing level to the top of the lip of the urinal, unless otherwise directed by the Engineer-in-Charge. The size of wooden plugs shall be 50 mm x 50 mm at base tapering to 38 mm x 38 mm at top and of length 5.0 cms. These shall be fixed in the wall in cement mortar 1:3 (1 cement: 3 fine sand). After the plug fixed in the wall, the mortar shall be cured till it is set.



**TABLE 17.3**

| No. of Urinals | Capacity of Flushing Cistern | Size of Flush Pipe (Galvanised Iron) |              |
|----------------|------------------------------|--------------------------------------|--------------|
|                |                              | Main                                 | Distribution |
| One            | 5 Litres                     | 15 mm                                | 15 mm        |
| Two            | 10 Litres                    | 20 mm                                | 15 mm        |
| Three          | 10 Litres                    | 25 mm                                | 15 mm        |
| Four           | 15 Litres                    | 25 mm                                | 15 mm        |

Each urinal shall be connected to 32 mm dia waste pipe which shall discharge into the channel or a floor trap. The connection between the urinal and flush or waste pipe shall be made by means of putty or white lead mixed with chopped hemp.

**17.9.2 Measurements**

Urinals shall be measured in numbers.

**17.9.3 Rate**

Rate shall include the cost of all the materials and labour involved in all the operations described above.

**17.10 INSTALLATION OF STALL URINAL (SINGLE OR RANGE)**

**17.10.0** The installation shall consist of stall urinal (single or range), automatic flushing cistern, C.P. brass standard flush pipes, C.P. brass spreader and C.I. trap with tail piece and outlet grating of C.P. brass. Capacity of flushing cistern and relevant size of flush pipe, C.I. trap shall be as prescribed in Table 17.4.

**TABLE 17.4**

| No. of Urinals in range | Capacity of Flushing cistern | Size of Flush Pipe (Chromium Plated) |              | Diameter of C.I. Traps |
|-------------------------|------------------------------|--------------------------------------|--------------|------------------------|
|                         |                              | Main                                 | Distribution |                        |
| One                     | 05 Litres                    | 15 mm                                | 15 mm        | 50 mm                  |
| Two                     | 10 Liters                    | 20 mm                                | 15 mm        | 50 mm                  |
| Three                   | 15 Litres                    | 25 mm                                | 15 mm        | 80 mm                  |
| Four                    | 15 Litres                    | 25 mm                                | 15 mm        | 80 mm                  |

**17.10.1 Fixing**

The floor slab shall be suitably sunk to receive the stall urinal. Where the floor slab is not sunk, the stall urinal shall be provided over a platform. The lip of the stall urinal shall be flush with the finished floor level adjacent to it. The stall urinal shall be laid over a fine sand cushion of average 25 mm thickness. A space of not less than 3 mm shall be provided all -round, in front, sides and filled with water proofing plastic compound. Care shall be taken that after the sub-grade for the floor is cast, one week should lapse before urinals are installed. The trap and fittings shall be fixed as directed by the Engineer-in-Charge. Payment for the floor and its sub-grade shall be made separately.

**17.10.2 Measurements**

Stall urinals shall be measured in numbers.

**17.10.3 Rate**

The rate shall include the cost of all the materials and labour involved in all the operations described above.

### **17.11 INSTALLATION OF WASH BASIN (FIG. 17.14, 17.15, 17.16, 17.17 & 17.18)**

**17.11.0** The installation shall consist of an assembly of wash basin, pillar taps, C.I. brackets, C.P. brass or P.V.C. union, as specified. The wash basin shall be provided with one or two 15 mm C.P. brass pillar taps, as specified. The height of top of the rim of wash basin from the floor level shall be within 750 mm to 800 mm.

#### **17.11.1 Fixing**

The basin shall be supported on a pair of C.I. cantilever brackets conforming to IS 775 and be embedded in cement concrete (1:2:4) block 100 x 75 x 150 mm. Use of M.S. angle or Tee section as bracket is not permitted. Brackets shall be fixed in position before dado work is done. The brackets have been shown in Fig. 17.15. The wall plaster on the rear shall be cut to rest over the top edge of the basin so as not to leave any gap for water to seep through between wall plaster & skirting of basin. After fixing the basin, plaster shall be made good and surface finished matching with the existing one. S.C.I. floor traps conforming to IS 1729 having 50 mm water seal (minimum 35 mm in two pipe systems with gully trap) should be used. Waste pipes laid horizontally should have gradient not flatter than 1 in 50 and not steeper than 1 in 10.

The waste water from wash basin shall be discharged directly to vitreous semi-circular open drain, discharging to a floor trap and finally to the vertical stack (Fig.17.15) on upper floors and in case of ground floor, the waste water shall be discharged either directly to the gully trap or through the floor trap (Fig. 17.16). C.P. brass trap and union are not to be used in such situations.

If waste pipe is concealed or crosses the wall, waste water shall be discharged through non ferrous trap like PVC Engineering plastic or C.P. brass and union (Fig. 17.17) to vertical stack. The C.P. brass trap and union shall be paid for separately.

Where so specified a 20 mm G.I. puff pipe terminating with a perforated brass cap screwed on it on the outside of the wall or connected to the antisiphon stack shall be provided.

#### **17.11.2 Measurements**

Wash basins shall be measured in numbers.

#### **17.11.3 Rate**

The rate shall include the cost of all the materials and labour involved in all the operations described above.

### **17.12 INSTALLATION OF SQUATTING PAN**

**17.12.0** The installation shall consist of squatting pan, flushing cistern, flush pipe and a pair of foot rests.

#### **17.12.1 Fixing**

The pan shall be sunk into the floor and embedded in a cushion of average 15 cm thick cement concrete 1:5:10 (1 Cement : 5 fine sand : 10 graded brick ballast 40 mm nominal size). The concrete shall be left 115 mm below the top level of the pan so as to allow flooring and its bed concrete. The pan shall be provided with a 100 mm S.C.I., P or S type trap with an approximately 50 mm seal and 50 mm dia vent horn, where required by the Engineer-in-Charge. The joint between the pan and the trap shall be made leak proof with cement mortar 1:1 (1 cement : 1 fine sand).

#### **17.12.2 Measurements**

The squatting pans shall be measured in numbers.

### 17.12.3 Rate

Rate shall include the cost of all the materials and labour involved in all the operations described above. Cost of concrete shall be paid separately.

## 17.13 INSTALLATION OF WATER CLOSET

**17.13.0** Installation shall consist of water closet with seat and cover, flushing cistern and flush bend.

### 17.13.1 Fixing

The closet shall be fixed to the floor by means of 75 mm long 6.5 mm diameter counter-sunk bolts and nuts embedded in floor concrete.

### 17.13.2 Measurements

Water closets shall be measured in numbers.

### 17.13.3 Rate

Rate shall include the cost of all the materials and labour involved in all the operations described above.

## 17.14 INSTALLATION OF FOOT RESTS

**17.14.1** After laying the floor around squatting pan as specified a pair of foot rests shall be fixed in cement mortar 1 : 3 (1 cement : 3 coarse sand). The position of foot rests with respect to pan shall be as per Fig. 17.4.

### 17.14.2 Measurements

Pair of foot rests shall be measured in numbers.

### 17.14.3 Rate

Rate shall include the cost of all the materials and labour involved in all the operations described above.

## 17.15 INSTALLATION OF SQUATTING PLATE (SINGLE OR RANGE) (FIG. 17.12)

**17.15.0** The installation shall consist of an assembly of squatting plates (single or range), vitreous China channel, automatic flushing cistern, flush pipe with fittings spreader and C.I. trap. The capacity of flushing cistern and relevant size of flush pipes shall be as specified in Table 17.5.

**TABLE 17.5**

| No. of Squatting Plates in range | Capacity of Flushing Cistern | Size of Flush Pipe (Galvanised Iron) |              |
|----------------------------------|------------------------------|--------------------------------------|--------------|
|                                  |                              | Main                                 | Distribution |
| One                              | 5 liters                     | —                                    | 20 mm        |
| Two                              | 10 liters                    | 25 mm                                | 20 mm        |
| Three                            | 15 liters                    | 32 mm                                | 20 mm        |
| Four                             | 15 liters                    | 32 mm                                | 20 mm        |

### 17.15.1 Fixing

The floor slab shall be suitably sunk to receive the squatting plate. Where the floor slab is not sunk, the plates shall be provided over a platform. The top edge of the squatting plate shall be flush with the finished floor level adjacent to it. It shall be embedded on a layer of 25 mm thick cement mortar 1:8 (1 cement: 8 fine sand) laid over a bed of cement concrete 1:5:10 (1 cement: 5 fine sand: 10 graded brick aggregate 20 mm nominal size).

There shall be 100 mm dia, white glazed vitreous China channels with stop and outlet pieces suitably fixed in the floor in cement mortar 1:3 (1 cement :3 coarse sand) and joint finished with white cement. The squatting plate shall have 1200 high and half brick thick wall in front and on either side of the squatting plate. The brick work for the walls shall be paid separately. The exposed surface of walls shall be lined with white glazed tiles with proper corners and angles set in neat cement mortar, the face of the joints shall be gone over with whiting so as to match with the colour of the tiles. The tiles shall be 15 mm square. Space if any, left between the side walls and squatting plate shall be finished white to match the colour of the squatting plate. The trap and fittings shall be fixed as directed by the Engineer-in-Charge. The vitreous China channel shall discharge into 65 mm diameter standard urinals, C.I. trap with vent arm having 65 mm C.P. brass outlet grating.

#### **17.15.2 Measurements**

Squatting plates shall be measured in numbers.

#### **17.15.3 Rate**

The rate shall include the cost of all the materials and labour involved in all the operations described above.

#### **17.16 INSTALLATION OF TOWEL RAIL**

It shall be fixed in position by means of C.P. brass screws on wall surface by PVC dash fasteners, firmly embedded in wall.

#### **17.16.1 Measurements**

Towel rails shall be measured in numbers.

#### **17.16.2 Rate**

Rate shall include the cost of all the materials and labour involved in all the operations described above.

#### **17.17 INSTALLATION OF STAINLESS STEEL SINK:-** Stainless steel A ISI 304 (18/8) kitchen sink.

The installation shall consist of assembly of sink C.I. brackets, union and G.I. or P.V.C. waste pipe.

#### **17.17.1 Fixing**

The stainless steel sink shall be fixing as per IS:13983 and shall be supported on C.I. cantilever brackets, embedded in cement concrete (1:2:4) block of size 100 x 75 x 150 mm. Brackets shall be fixed in position before the dado work is done. The C.P. brass or P.V.C. union shall be connected to 40 mm nominal bore G.I. or PVC waste pipe which shall be suitably bent towards the wall and shall discharge into a floor trap. C.P. brass trap and union and waste shall be paid separately. The height of front edge of sink from the floor level shall be 80 cm.

#### **17.17.2 DIMENSIONS AND TOLERANCES**

##### **17.17.2.1** Thickness of Sheet/Strip

**17.17.2.2** Nominal thickness of stainless steel sheet/ strip used in the construction of sink shall be not less than 1.00 mm before forming.

**17.17.2.3** Thickness at any point of sink, after forming, shall not be less than 0.75 mm.

##### **17.17.3 Depth of Bowls**

The depth of the sink bowl shall be 150 mm minimum, when measured from the top edge of the bowl to the base of the sink.

NOTE - Depth of smaller bowl shown in Fig. 1 for Type E2 and E3 may be reduced up to 100 mm.

#### **17.17.4 Internal Dimensions of Bowls**

The minimum internal dimensions, when measured on the bowl centre lines across the top of the bowl, shall be 380 mm x 340 mm for rectangular bowls and 360 mm for round bowls.

NOTES I. There is no restriction on bowl shape provided the minimum dimensions given in this clause are complied with.

1. Internal width of smaller bowl shown in Flg. 1 for Type E2 and E3 may be reduced as per the manufacturers design.

#### **17.17.5 Bowl Locating Limits**

**17.17.5.1** The distance between the edge of the sink bowl and the end of the sink shall be 15 mm minimum for sit-on type sinks and 30 mm minimum for inset type sinks. Depth of the collar provided for inset sinks shall be  $10 \pm 2$  mm,

**17.17.5.2** For sinks designed for use with a 600 mm wide work top, the distance between the edge of the sink bowl and the front of the sink shall be 50 mm minimum and in the case of sinks designed for use with 500 mm wide worktop, the distance shall be 45 mm minimum.

**17.17.5.3** Both single and double bowl sink shall be set a minimum of 10 mm from gridline.

#### **17.17.6 Measurements**

The sinks shall be measured in numbers.

#### **17.17.7 Rate**

Rate shall include the cost of all materials and labour involved in all the operations described above but shall not included the cost of waste fitting and brackets which shall be paid for separately.

### **17.18 CUTTING CHASE IN MASONRY WALL**

**17.18.1** Cutting chasing in brick masonry wall shall be has specified in item no. 18.22.

#### **17.18.2 Filling chases**

After sand cast iron/ centrifugally cast/spun iron pipe etc. are fixed in chases, the chases shall be filled with cement concrete 1:3:6 (1 cement: 3 coarse sand: 6 graded stone aggregate 12.50 mm nominal size) or cement mortar 1:4 (1 cement: 4 coarse sand) as may be specified or otherwise directed by the Engineer-in-Charge and made flush with the masonry surface. The concrete surface shall be roughened with wire brushes to provide a key for plastering.

#### **17.18.3 Measurements**

Chases shall be measured in running meter correct to a cm.

#### **17.18.4 Rates**

The rate shall include the cost of labour the materials involved in all the operations described above excluding the cost of providing pipes etc. which shall be paid separately.

### **17.19 PAINTING SYNTHETIC ENAMEL PAINT ON SCI/CENTRIFUGALLY CAST (SPUN) IRON SOIL, WASTE AND VENT PIPES.**

**17.19.1** The primer and paint of approved brand and manufacturer shall be used as specified. Paint shall be synthetic enamel paint of any color such as chocolate, grey or buff etc.

#### **17.19.2 Painting new surface**

**17.19.2.1 Preparation of surface:-** The surface of pipe and fittings shall be thoroughly cleaned. All unevenness shall be rubbed down and made them smooth with sand paper and dust shall be removed properly. After obtaining approval of Engineer-in-Charge, for SCI/CI pipe, the priming coat shall be applied before the pipe is fixed in position.

**17.19.2.2 Application:-** The primer shall be applied with brushes properly on the pipe surface and spread even and smooth. The application of synthetic enamel paint over priming coat shall be carried out after drying of primer surfaces. Additional finishing coat shall be applied if found necessary, to ensure proper uniform surface. The two coats of synthetic enamel paint shall be applied. The second coat shall be applied when the previous coat has dried up.

**17.19.3 Measurement:-** Measurement shall be taken over the finished line of pipe including specials and fittings such as socket, tee, bend, cowl, holder bat clamp etc. in running meter correct to a centimeter. Pipe of different diameter shall be measured and paid for separately.

**17.19.4 Rate:-** The rate shall be inclusive of cost of all materials and labours involved in all the operations described above including painting all specials and fittings etc.

## **17.20 REPAINTING SCI / CENTRIFUGALLY CAST (SPUN) IRON SOIL, WASTE AND VENT PIPE**

**17.20.1** The synthetic enamel paint of approved brand and manufacturer shall be used as specified.

### **17.20.2 Painting old surface.**

**17.20.2.1 Preparation of surface:-** The old surface shall be cleaned off by removing grease, smoke etc. The surface of pipe shall then be thoroughly cleaned, rubbed down with sand paper and dusted. Rusted patches shall be cleared up and touched with synthetic enamel paint. If the old paint is blistered and flaked, it shall be completely removed as described in 13.41. Such removal shall be paid for separately and painting shall be treated as on new work.

**17.20.2.2 Application:-** The paint shall be applied with brushes properly on the pipe surface and spread even and smooth. The one coat of paint to be applied. Additional finishing coat shall be applied if found necessary to ensure proper uniform surface.

**17.20.3 Measurement:-** Same as described in the 17.19.3.

**17.20.4 Rate:-** The rate shall be inclusive of cost of all materials and labours involved in all the operations described above, including painting all specials and fittings etc.

## **17.21 INSTALLATION OF WALL MOUNTING WATER CLOSET (WC)**

### **17.21.1 Installation**

It shall consist of white vitreous china extended wall mounting WC of size 780x370x690 mm of approved shape, brand and manufacture with dual flush fitting of flushing capacity 3 Ltr / 6 Ltr (adjustable to 4 Ltr/8 Ltr) including seat cover and cistern fittings, nuts, bolts and gasket etc. complete in all respect as per direction of Engineer-in-Charge. Wall mounting water closet shall be of white vitreous China confirming to IS 2556 (Part 16) : 2002. For general requirement relating to terminology, materials, manufacture, glazing, defects, minimum thickness, tolerances, performance and methods of tests shall confirm to IS 2556 (Part 1). Wall mounted water closet shall be of one piece construction. Each wall mounted water closet shall be provided with fixing arrangement and shall have an integral flushing rim of suitable type. It shall have an inlet for connecting the flushing pipe of dimension confirming to IS 2556 and mentioned in Table No.2. The flushing rim may be box or open rim type or a combination of both. In case of box rim, adequate number of holes and slot be provided. The flushing rim and the inlet shall be of the self draining type and weep hole shall be provided at the flushing inlet of the wall mounted water closet.

The WC shall be provided with not less than two fixing holes to enable the WC to be securely installed to the wall using metallic corrosion resistant bolts and nuts and an independent concealed support frame. The support frame (metal hanger or carrier), depending on the design shall be securely attached to the building structural members so that no strain is transmitted to WC connector or any part of the plumbing system.

Each wall mounted water closet shall have an integral trap and P type outlet confirming to IS 2556 (Part 16): 2002 and mentioned in Fig. 25 & Fig. 26. Inside surface of water closet and trap shall be uniform and smooth in order to ensure an efficient flushing. The outlet if without serration, shall be glazed and if same is with serration, may not be glazed.

### **17.21.2 Marking**

Each piece of wall mounted water closet shall be clearly and indelibly marked at a suitable place with the following:-

- (a) Name of trade mark of the manufacturer and
- (b) Batch/lot numbers.

### **17.21.3 BIS certification marking**

Wall mounted water closet shall be marked with the standard mark. The use of Standard Mark is governed by the provisions of the Bureau of Indian Standards Act, 1986 and the Rules and Regulations made .

### **17.21.4 General requirement for installation of WC**

The specification described in 17.2 shall be hold good so far as it is applicable.

**17.21.4.1** All sanitary and plumbing work shall be carried out through licensed plumbers.

**17.21.4.2** On completion of the work the site shall be cleaned and all rubbish disposed off as directed by the Engineer-in-Charge.

### **17.21.5 Measurement**

Wall mounted water closet shall be measured in numbers.

## **17.22 INSTALLATION OF FLOOR MOUNTED SINGLE PIECE WATER CLOSET (WC)**

### **17.22.1 Installation**

It shall consist of white vitreous China single piece, double traps syphonic water closet of approved shape, brand, size, pattern and manufacturer with integrated white vitreous china cistern of capacity 10 ltr. with dual flushing system, including all fitting and fixtures with seat cover, cistern fittings, nuts, bolts and gasket etc. including making connection with the existing P/S trap, complete in all respect as per direction of the Engineer-in-Charge.

The general requirement relating to terminology, materials, manufacture, glazing, defects, minimum thickness, tolerances, performance and methods of tests shall confirm to IS 2556 (Part-1).

Single piece floor mounted WC generally smaller than a two piece floor mounted WC. The flushing tank is connected and sits lower on the bowl than on a two piece. Due to the smaller size, single piece WC are able to be installed in toilet/bathroom with less square footage.

### **17.22.2 Fixing**

The water closet shall be fixed to the floor by means of 75mm long and 6.5mm dia counter sunk bolts and nuts embedded in the floor concrete.

### **17.22.2.3 Marking**

Each piece of wall mounted water closet shall be clearly and indelibly marked at a suitable place with the following:-

- (a) Name of trade mark of the manufacturer and
- (b) Batch/lot numbers.

### **17.22.3 General requirement for installation of WC**

The specification described in 17.2 shall be hold good so far as they are applicable.

**17.22.3.1** All sanitary and plumbing work shall be carried out through licensed plumbers.

**17.22.3.2** On completion of the work the site shall be cleaned and all rubbish disposed off as directed by the Engineer-in-Charge.

### **17.22.4 Measurement**

Single piece floor mounted water closet shall be measured in numbers.



**STANDARD WEIGHTS AND THICKNESS OF C.I. PIPES***(Clause 17.1.8)*

For Sand Cast Iron Pipes IS 1729

| Nominal dia of bore<br>(mm) | Thickness<br>(mm) | Over all weight of pipe |                  |                 |
|-----------------------------|-------------------|-------------------------|------------------|-----------------|
|                             |                   | 1.5 m long (Kg)         | 1.80 m long (Kg) | 2.0 m long (Kg) |
| 50                          | 5.0               | 9.56                    | 11.41            | 12.65           |
| 75                          | 5.0               | 13.83                   | 16.52            | 18.37           |
| 100                         | 5.0               | 18.14                   | 21.67            | 24.15           |
| 150                         | 5.0               | 26.70                   | 31.92            | 35.66           |

For Cast Iron (Spun Pipes IS 3989).

| Nominal dia<br>(mm) | Thickness<br>(mm) | Overall Weight in Kg. for an effective length in metres of |       |       |       |       |
|---------------------|-------------------|--|-------|-------|-------|-------|
|                     |                   | 3.000  | 2.500 | 2.000 | 1.800 | 1.500 |
| 50                  | 3.5               | 13.40  | 11.3  | 9.2   | 8.4   | 7.1   |
| 75                  | 3.5               | 20.0   | 16.8  | 13.8  | 12.5  | 10.6  |
| 100                 | 4.0               | 30.0   | 25.5  | 21.0  | 18.8  | 16.0  |
| 150                 | 5.0               | 56.0   | 47.0  | 38.5  | 34.9  | 29.5  |

**Tolerances**

(a) Tolerances on the external diameter of the barrel, the internal diameter of the socket and the depth of socket shall be as follows:—

| Dimensions (mm)             | Nominal Diameter (mm) | Tolerance |
|-----------------------------|-----------------------|-----------|
| External diameter of barrel | 50, 75                | ± 3.0     |
|                             | 100                   | ± 3.5     |
|                             | 150                   | ± 4.0     |
| Internal diameter of socket | All diameters         | ± 3.0     |
| Depth of socket             | All diameters         | 10.0      |

The maximum and minimum jointing space resulting from these tolerances shall be such that the jointing of the pipes and fittings is not adversely affected.

The tolerance on length of pipes shall be ± 20 mm.

(b) The tolerances on dimensions of fittings shall be as given below:

| Type of Casting                    | Dimension | Tolerance mm |
|------------------------------------|-----------|--------------|
| Bend pipes                         | a         | +25 -10      |
|                                    | b         | +20 -10      |
| Branches with equal branch pipes   | a         | +25 -10      |
|                                    | b         | +25 -10      |
| Branches with unequal branch pipes | L         | +30 -20      |
| S. Shape casting                   | L         | +50 -10      |
| Taper collars                      | L         | +25 -10      |
| Other                              | L         | +20 -10      |

**Note:**

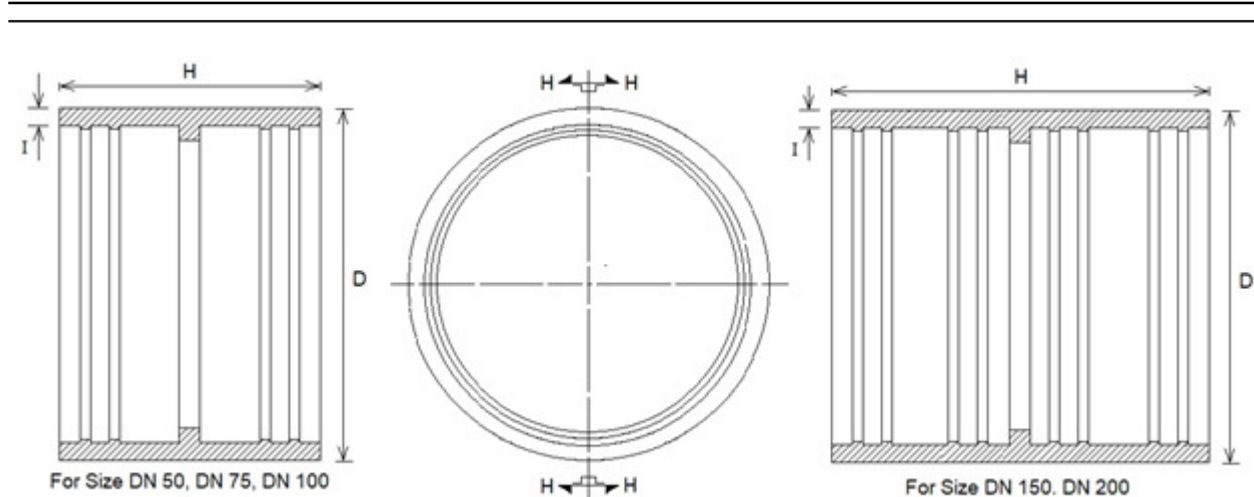
- (1) Tolerance on wall-thickness shall be limited to -15 per cent. No limits for plus tolerance is specified.
- (2) Tolerance for dimensions other than those specified above shall be as specified in IS 5519.
- (3) Tolerance on mass shall be limited to -10 per cent. No limit for plus tolerance specified.

**DRAWING AND DIMENSIONS FOR STAINLESS STEEL SHIELDED COUPLING**

A-1 Profile of EPDM rubber gasket as given in Table-6.

A-2 Design of stainless steel shield and clamp as given in Table-7.

**Table- 6 EPDM Rubber Gasket  
(Clause A-1)**



| Sl No. (1) | DN mm (2) | Outside Dia (D) Mm (3) | Thickness (l) Mm (4) | Height (H) mm (5) |
|------------|-----------|------------------------|----------------------|-------------------|
| i)         | 50        | 59.8                   | 2.4                  | 54                |
| ii)        | 75        | 84.8                   | 2.4                  | 54                |
| iii)       | 100       | 111.0                  | 2.5                  | 54                |
| iv)        | 150       | 162.0                  | 3.0                  | 76                |
| v)         | 200       | 211.0                  | 3.0                  | 101               |

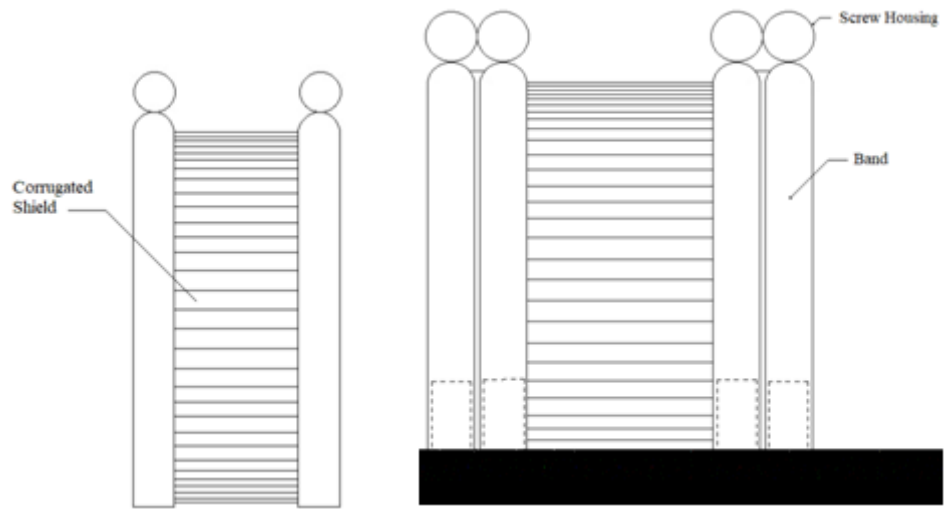
A-3.2 Firmly seat the pipe or fitting ends against the integrally moulded center stop inside the EPDM rubber gasket.

A-3.3 Slide the stainless steel shield and clamp assembly over the EPDM rubber gasket and tighten the bands. For larger diameter couplings which have four bands, the inner bands should be tightened first and then the outer bands.

A-3.4 In all the cases, when tightening bands they should be tightened alternately to insure that the coupling shield is drawn up uniformly.

NOTE — Other types of joints can also be used at the discretion of the customer. The details given in this Annex is for guidance only

**Table-7 Stainless Steel Shield**  
(Clause A-2)



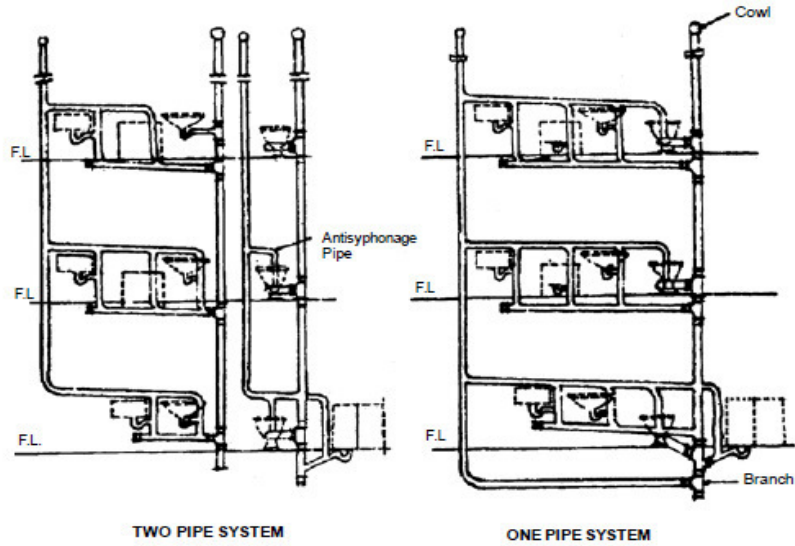
For Size DN50, DN75, DN100

For Size DN50, DN75, DN100

| Sl. No. | DN<br>mm | Height (H)<br>mm |
|---------|----------|------------------|
| (1)     | (2)      | (3)              |
| i)      | 50       | 54               |
| ii)     | 75       | 54               |
| iii)    | 100      | 54               |
| iv)     | 150      | 76               |
| v)      | 200      | 101              |

## PIPE SYSTEMS AND PARTS

Sub Head : Sanitary Installations  
Clause : 17.1

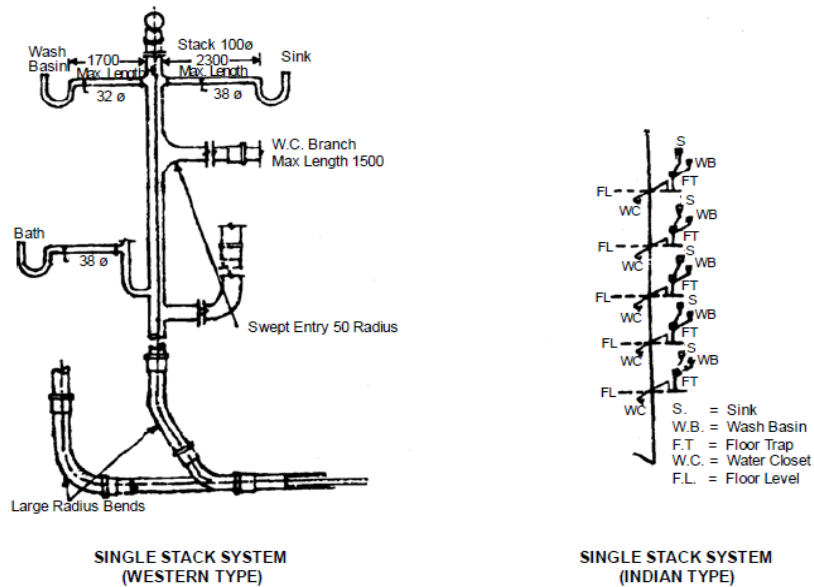


Drawing Not to Scale  
All Dimensions are in mm

**Fig. 17.1 : Pipe Systems and Parts**

## PIPE SYSTEMS AND PARTS

Sub Head : Sanitary Installations  
Clause : 17.1



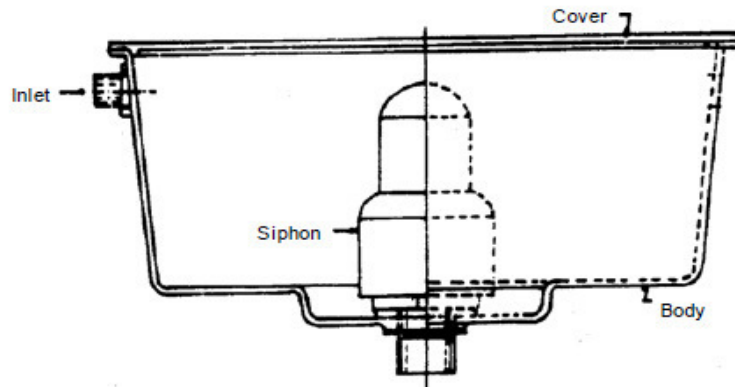
Drawing Not to Scale  
All Dimensions are in mm

**Fig. 17.2 : Pipe Systems and Parts**

# FLUSHING CISTERNS

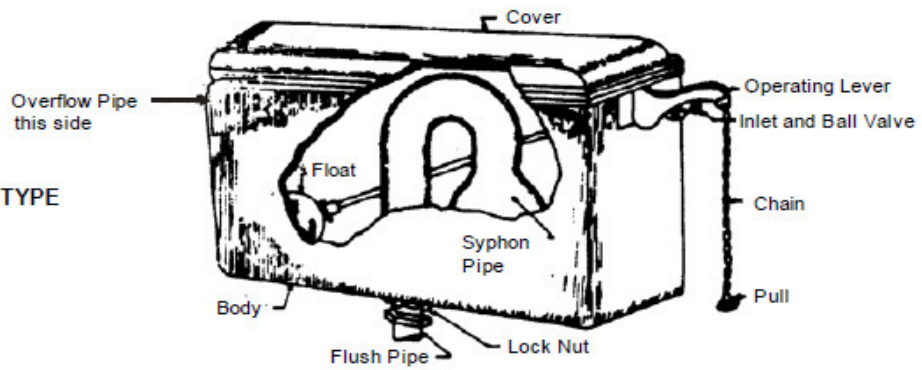
Sub Head : Sanitary Installations  
Clause : 17.1.1

AUTOMATIC TYPE

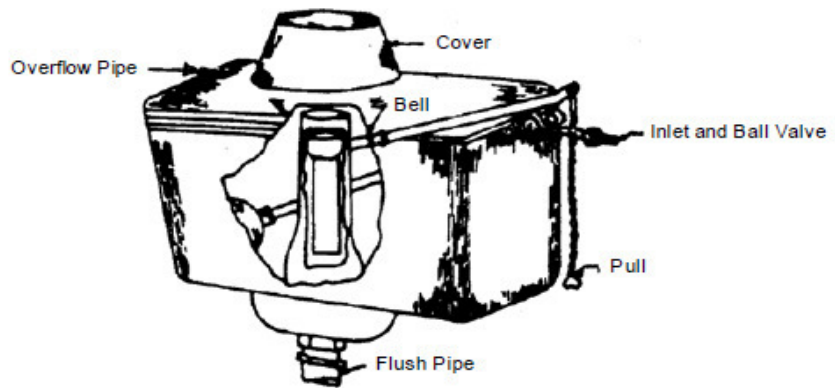


Body is Shown in Half Section

CURVED SIPHON TYPE



BELL TYPE

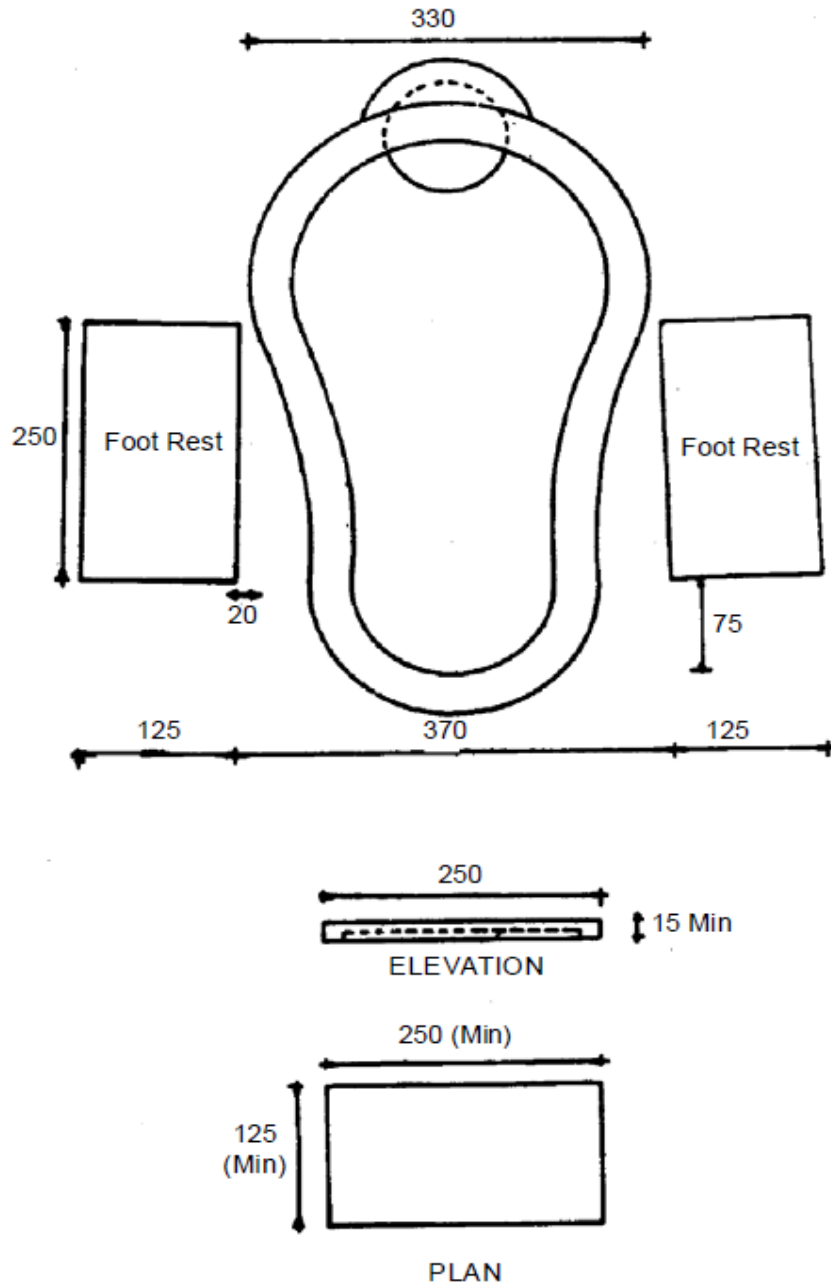


Drawing Not to Scale  
All Dimensions are in mm

Fig. 17.3 : Flushing Cisterns

# FOOT REST

Sub Head : Sanitary Installations  
Clause : 17.1.3

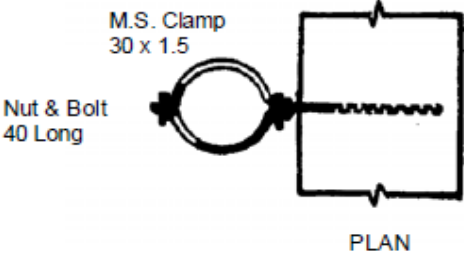
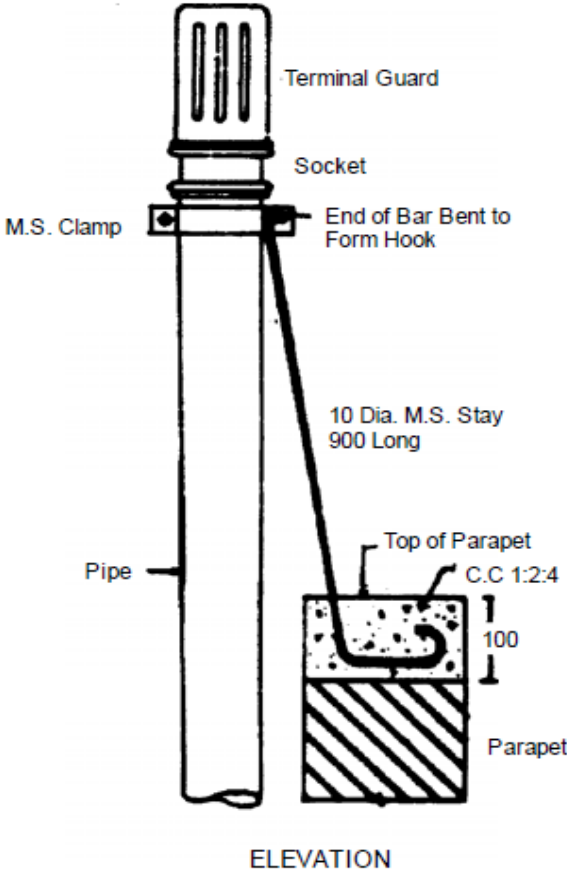


Drawing Not to Scale  
All Dimensions are in mm

Fig. 17.4 : Foot Rest

# M.S. STAYS AND CLAMP

Sub Head : Sanitary Installations  
Clause : 17.1.6



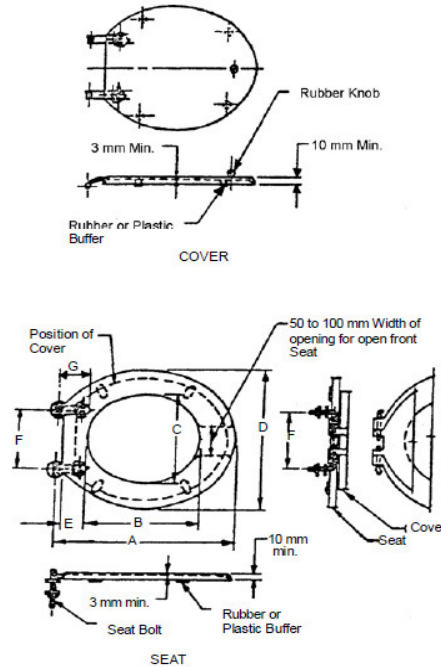
Drawing Not to Scale  
All Dimensions are in mm

Fig. 17.5 : M.S. Stays and Clamp



## PLASTIC SEAT AND COVER

Sub Head : Sanitary Installations  
Clause : 17.1.9



**Table 1 Dimensions of Seats and Covers**  
*All dimensions in millimeters*

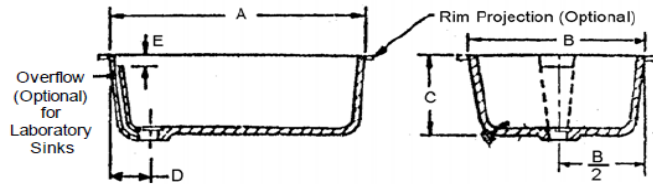
| Sl.No  | Description   | Dimensions |     |
|--------|---|------------|-----|
|        |   | Min        | Max |
| (1)    | (2)   | (3)        | (4) |
| (i)    | Distance from centre line of hinge bolts to extreme edge of rim at front, <i>A</i>  | 445        | 475 |
| (ii)   | Length of opening at longest point, <i>B</i>  | 250        | 290 |
| (iii)  | Width of opening at widest point, <i>C</i>  | 215        | 240 |
| (iv)   | Overall width at widest point, <i>D</i>   | 380        | -   |
| (v)    | Distance between inner and outer rims, <i>E</i>                                     | 55         | -   |
| (vi)   | Centre-to-centre distance of seat bolt holes, <i>F</i>                              | 145        | 175 |
| (vii)  | Distance from centre line of hinge bolts to inner rim of seat at the back, <i>G</i> | 85         | -   |
| (viii) | Thickness of seat at thinnest point   | 3          | -   |
| (ix)   | Thickness of cover at thinnest point  | 3          | 1   |

**Note :** Some hinging devices are made so as to provide adjustment in the longitudinal direction. This is not precluded by these figures.

**Fig. 17.6 : Plastic Seat and Cover**

# KITCHEN & LABORATORY SINKS

Sub Head : Sanitary Installations  
Clause : 17.1.10

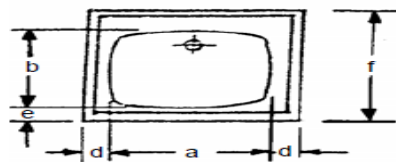


KITCHEN AND LABORATORY SINKS (WHITE GLAZED FIRE CLAY)

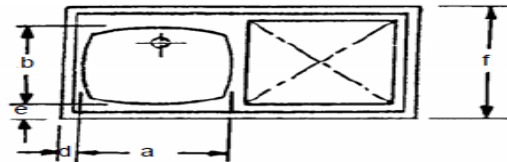
## DIMENSIONS OF KITCHEN AND LABORATORY SINKS (White Glazed Fire Clay)

All dimensions in millimeters

| Pattern (1)  | Size (2)        | A (3) | B (4) | C (5) | D (6) |
|--|-----------------|-------|-------|-------|-------|
| (a) Kitchen sinks<br>(White glazed fire clay)              | 750 x 450 x 250 | 750   | 450   | 250   | 150   |
|  | 600 x 450 x 250 | 600   | 450   | 250   | 150   |
|  | 600 x 450 x 200 | 600   | 450   | 200   | 150   |
| (b) Kitchen sink with<br>drain board stainless steel       | 510x1040x250    | 510   | 1040  | 250   | 150   |
|  | 510x1040x225    | 510   | 1040  | 225   | 150   |
|  | 510x1040x200    | 510   | 1040  | 200   | 150   |
|  | 510x1040x178    | 510   | 1040  | 178   | 150   |
| (c) Kitchen sink<br>without drain board<br>stainless steel | 610x510x200     | 610   | 510   | 200   | 150   |
|  | 610x460x200     | 610   | 460   | 200   | 150   |
|  | 470x420x178     | 470   | 420   | 178   | 150   |
| (d) Laboratory sinks                                       | 600 x 400 x 200 | 600   | 450   | 200   | 90    |
|  | 500 x 350 x 150 | 600   | 350   | 150   | 90    |
|  | 450 x 300 x 150 | 450   | 300   | 150   | 90    |
|  | 400 x 250 x 150 | 400   | 250   | 150   | 90    |



WITHOUT DRAINING BOARD



WITH DRAINING BOARD

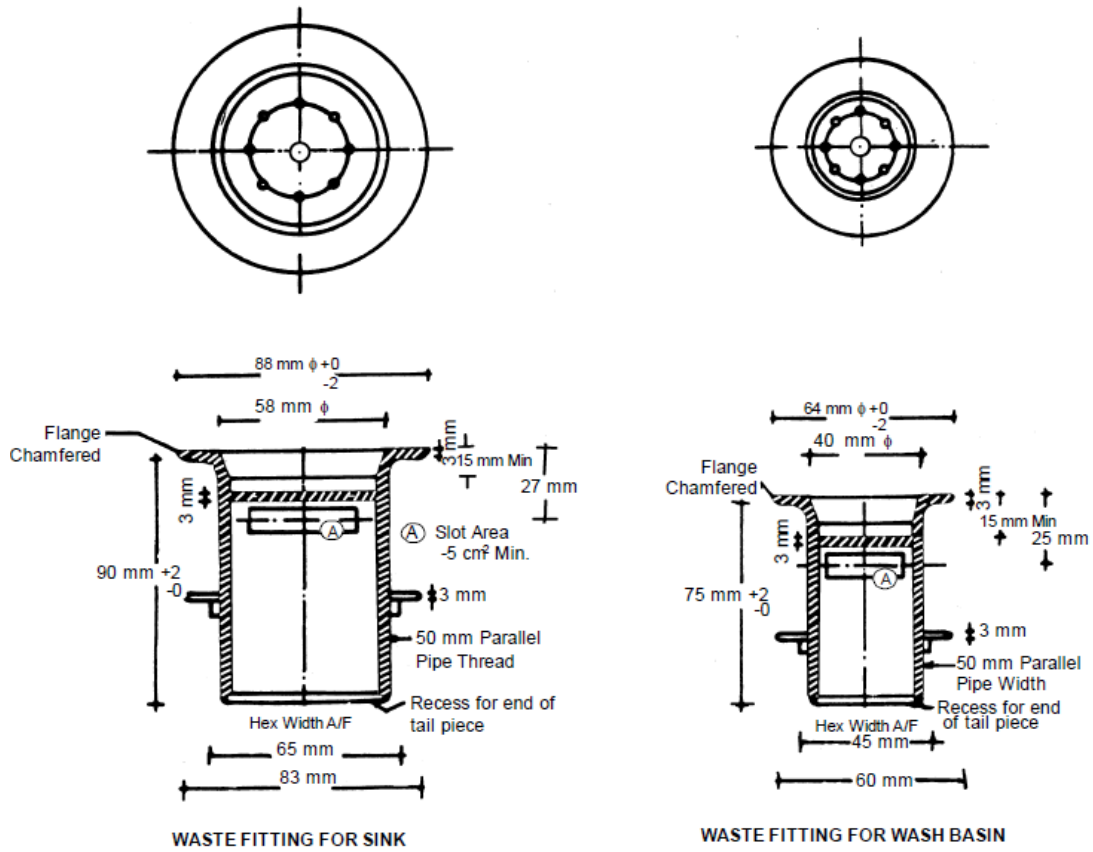
| Reference to Fig. above | Dimensions in mm<br>(Minimum Unless Specified)                 |
|-------------------------|--|
| a                       | 380 (for rectangular bowl)<br>360 (for round bowl)             |
| b                       | 340  |
| c                       | 20   |
| d                       | 30   |
| e                       | 45   |
| f                       | 440 mm Max for 500 mm worktop<br>515 mm Max for 600 mm worktop |

STAINLESS STEEL SINK

Fig. 17.7 : Kitchen & Laboratory Sinks

# WASTE FITTINGS FOR W.B. & SINKS

Sub Head : Sanitary Installations  
 Clause : 17.1.15



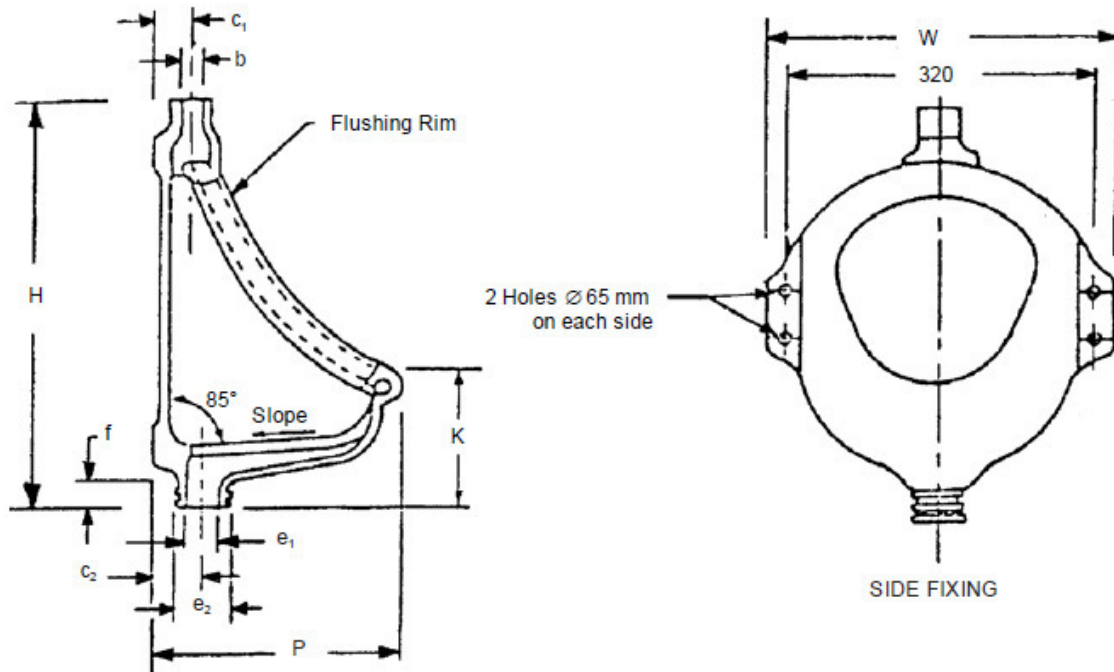
Drawing Not to Scale  
 No. and Sizes of Holes Indicative

Fig. 17.8 : Waste Fittings for W.B. & Sinks

## URINAL BOWL TYPE

Sub Head : Sanitary Installations

Clause : 17.1.13



**Note :** Where a closed channel with overflow is not provided a domed grating with perforating starting from the base and the crown of which shall be 25 mm, minimum above surface shall be provided which may be integral or otherwise.

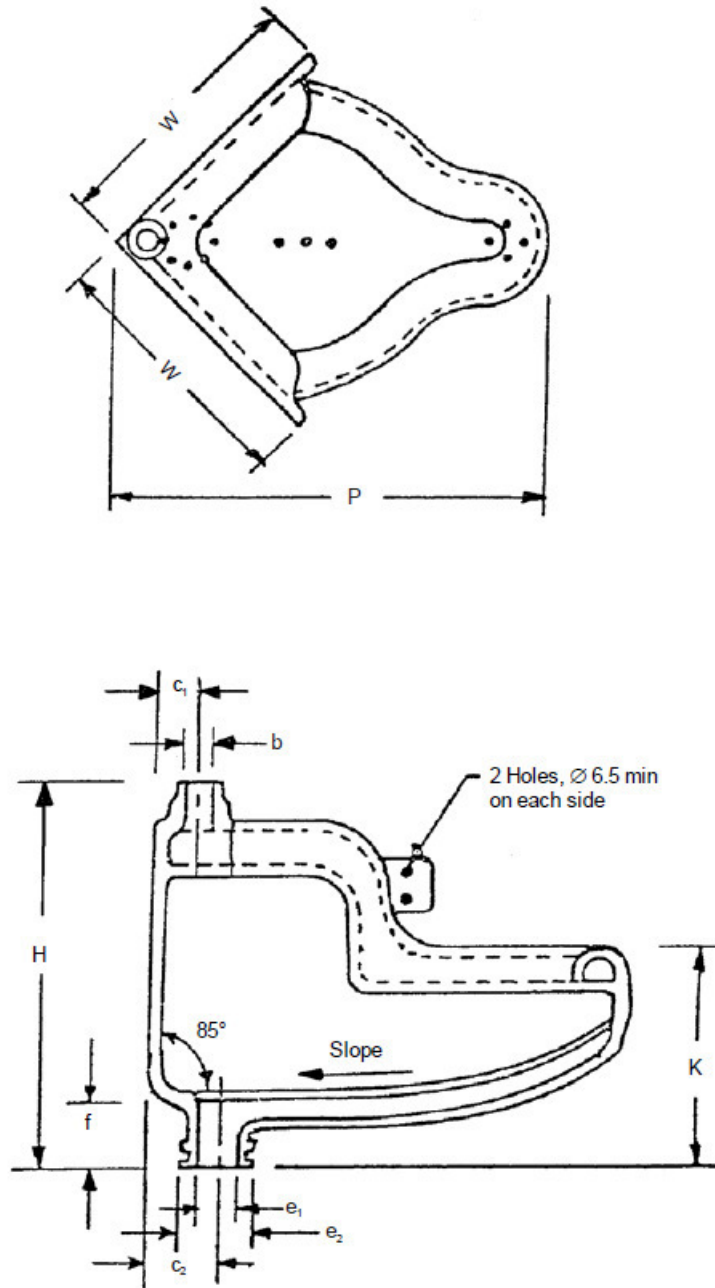
### BOWL PATTERN URINAL (FLAT BACK)

All dimensions in millimetres

Fig. 17.9 : Urinal Bowl Type

## URINAL BOWL TYPE (Contd.)

Sub Head : Sanitary Installations  
Clause : 17.1.13



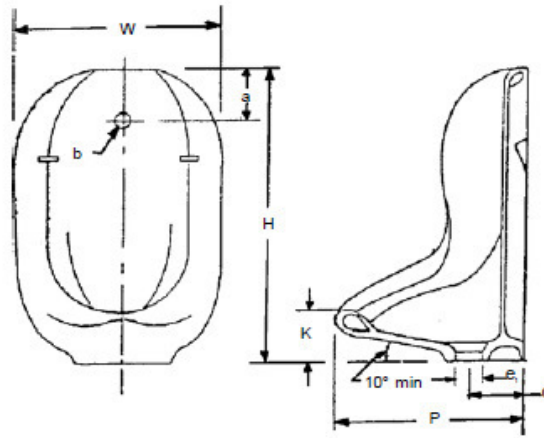
**Note :** Ovality of 5 percent is permissible on inlet and outlet diameters.

All Dimensions in Millimetres

**Fig. 17.10 : Urinal Bowl Type (Corner Wall Type)**

# URINAL – HALF STALL

Chapter : Sanitary Installations  
Clause : 17.1.13.2



**BOWL TYPE FLAT BACK URINAL WITHOUT RIM**

## FUNCTIONAL DIMENSIONS OF BOWL PATTERN URINALS

All dimensions in millimetres

| Sl. No. | Pattern                         | Dimension   |                 |            |                    |
|---------|---------------------------------|-------------|-----------------|------------|--------------------|
|         |                                 | Height<br>H | Projection<br>P | Width<br>W | Distance<br>K, Min |
| 1.      | Flat back with flushing rim     |             |                 |            |                    |
|         | Size 1                          | 440         | 265             | 355        | 140                |
|         | Size 2                          | 440         | 265             | 315        | 140                |
| 2.      | Flat back without flushing rim  |             |                 |            |                    |
|         | Size 1                          | 410         | 265             | 305        | 100                |
|         | Size 2                          | 590         | 375             | 390        | 100                |
| 3.      | Angle back with flushing rim    | 345         | 420             | 270        | 190                |
| 4.      | Angle back without flushing rim |             |                 |            |                    |
|         | Size 1                          | 450         | 350             | 275        | 100                |
|         | Size 2                          | 580         | 500             | 300        | 100                |

## CONNECTING DIMENSIONS OF BOWL PATTERN URINALS

All dimensions in millimetres

| Sl.No. | Pattern                          | Dimension in mm |        |                |  |        |                |                |        |
|--------|----------------------------------|-----------------|--------|----------------|--|--------|----------------|----------------|--------|
|        |                                  | a               | b      | c <sub>1</sub> | c <sub>2</sub>                             | d      | e <sub>1</sub> | e <sub>2</sub> | f, Min |
| 1.     | Flat back, with flushing rim     | —               | 20 ± 3 | 40 ± 5         | 50 ± 5                                     | —      | 35 ± 2         | 55             | 20     |
| 2.     | Flat back, without flushing rim  | 75<br>Max       | 20 ± 3 | —              | 100 Min                                    | 65 ± 5 | 45 ± 2         | 60 Min         | 20     |
| 3.     | Angle back, with flushing rim    | —               | 20 ± 3 | 35 ± 5         | 65 ± 5                                     | —      | 35 ± 2         | 55             | 20     |
| 4.     | Angle back, without flushing rim | 75<br>max       | 20 ± 3 | —              | 150<br>(for size 1)<br>225<br>(for size 2) | 65 ± 5 | 45 ± 2         | 60             | 20     |

### Explanation for Legends Used

- a = Dimension from top of bowl to centre of water supply hole or spreade
- b = Diameter of water supply hole
- c<sub>1</sub> = Distance from centre of water supply hole to back of bowl
- c<sub>2</sub> = Distance from centre of waste outlet to back of bowl
- d = Dimension of outlet of the waste flange
- e<sub>1</sub> = Internal diameter of waste outlet
- e<sub>2</sub> = Outside diameter of the outlet hole
- f = Depth of waste outlet

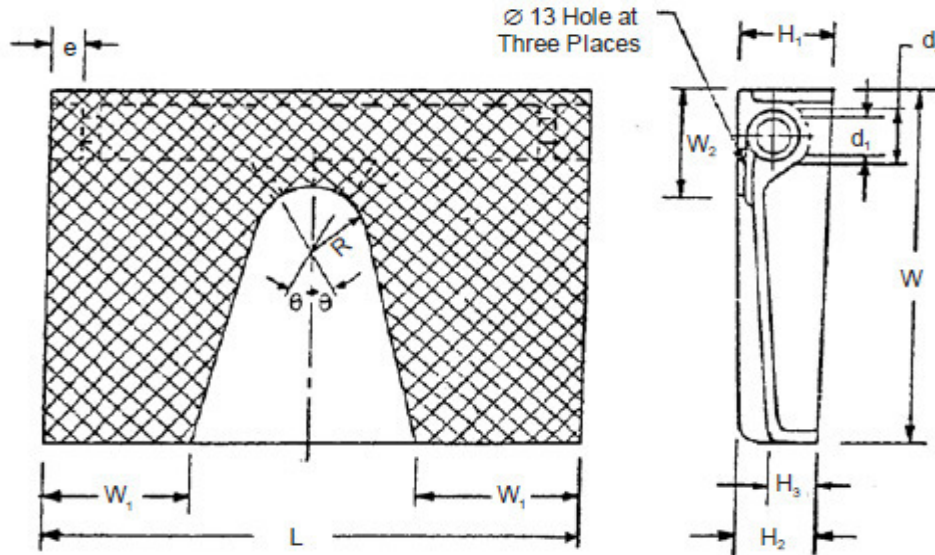
Note : Distance between pairs of screw holes for flat back with flushing rim bowl urinal shall be 395 mm for top/bottom fixing arrangement and 320 mm for side fixing arrangement.

- (1) Ovality is permissible within the variation allowed for the dimensions
- (2) Ovality is permissible within ± 2 mm of the dimensions.

**Fig. 17.11 : Urinal – Half Stall**

## URINAL SQUATTING PLATE

Sub Head : Sanitary Installations  
Clause : 17.1.13.4



### SQUATTING PLATE URINAL

#### FUNCTIONAL DIMENSIONS OF SQUATTING PLATES (IN MM)

| Sl.No. | Description   | Ref. in Fig. above | Size 1    | Size 2    |
|--------|---|--------------------|-----------|-----------|
| 1.     | Size  | —                  | 450 x 350 | 600 x 350 |
| 2.     | Length  | $L$                | 450       | 600       |
| 3.     | Minimum foot rest width   | $W_1$              | 125       | 165       |
| 4.     | Width   | $W$                | 350       | 350       |
| 5.     | Height at back end  | $H_1$              | 100       | 100       |
| 6.     | Height at front end   | $H_2$              | 85        | 85        |
| 7.     | Minimum height at bowl draining surface                                   | $H_3$              | 50        | 50        |
| 8.     | Width at flat top   | $W_2$              | 100       | 100       |
| 9.     | Radius of curvature of the bowl   | $R$                | 65        | 65        |
| 10.    | Angle of direction of the two end spray hole with that of the central one | $\theta$           | 30°       | 30°       |

#### CONNECTING DIMENSIONS OF SQUATTING PLATES, MM

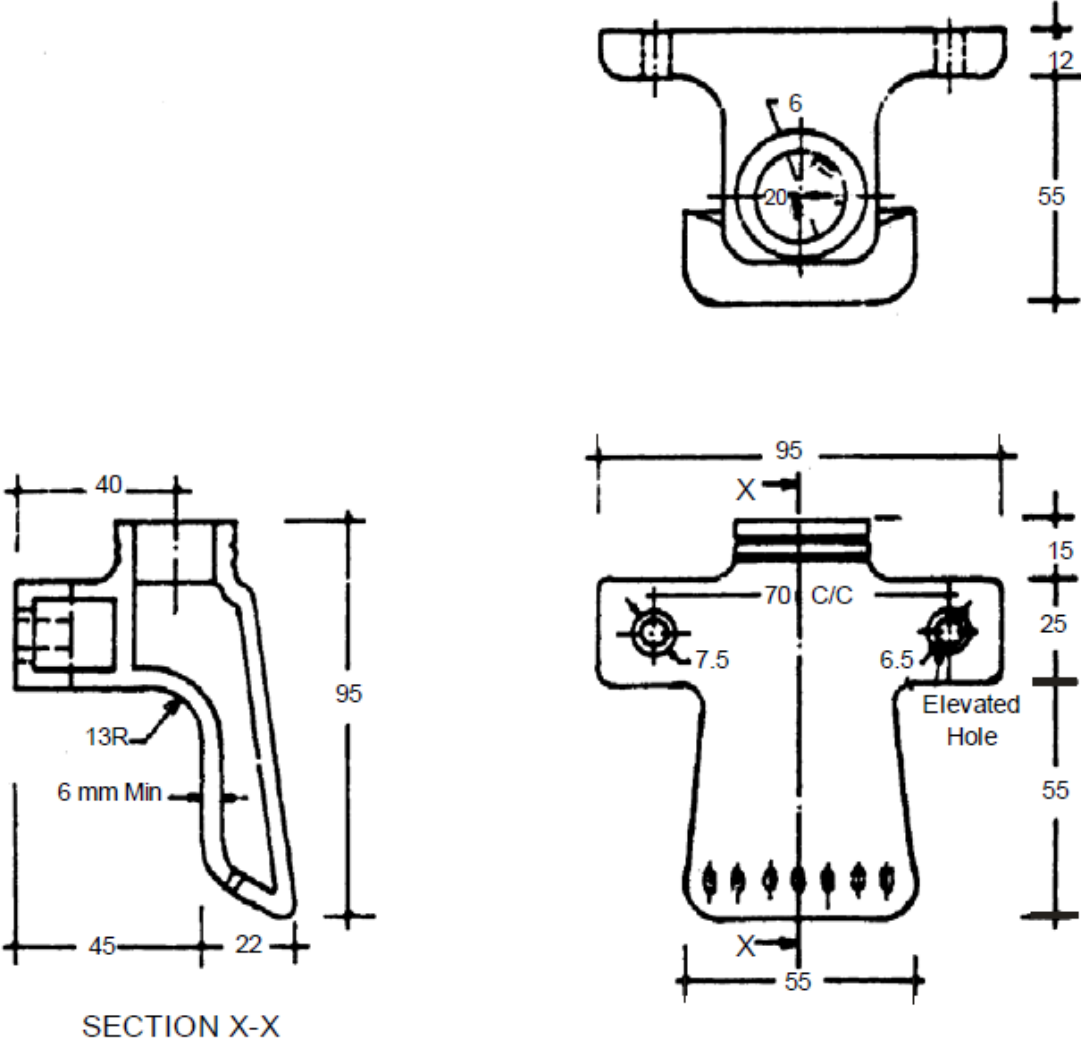
| Description                    | Ref. in Fig. above | Size 1/Size 2 |
|--------------------------------|--------------------|---------------|
| Diameter of inlet hole         | $d_1$              | 40            |
| Diameter of the inlet socket   | $d_2$              | 50            |
| Depth of the inlet socket, Min | $e$                | 25            |

1) Ovality is permissible within the variation allowed for the dimensions.

**Fig. 17.12 : Urinal Squatting Plate**

# SPREADER FOR URINAL

Sub Head : Sanitary Installations  
 Clause : 17.1.13



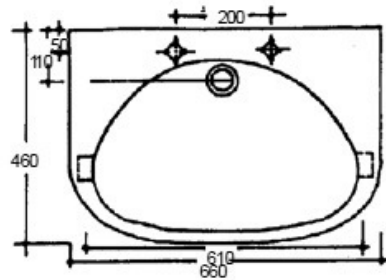
Drawing Not to Scale  
 All dimensions are in mm

Fig. 17.13 : Spreader for Urinal

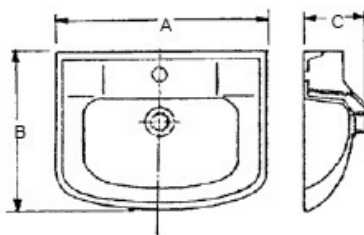
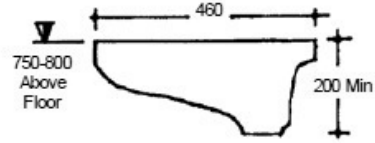


# WASH BASINS

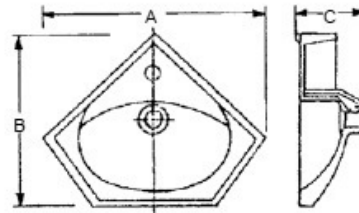
Sub Head : Sanitary Installations  
 Clause : 17.1.14



SURGEONS BASIN



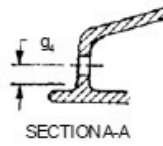
FLAT BACK



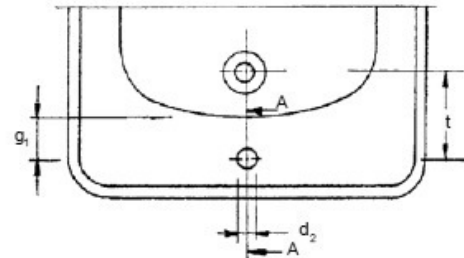
ANGLE BACK

**FUNCTIONAL DIMENSIONS OF WASH BASINS**  
 All dimensions in millimetres

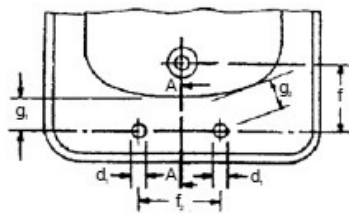
| S. No. | Pattern    | Size              | Length |     | Breadth  |  | Height |
|--------|------------|-------------------|--------|-----|----------|--|--------|
|        |            |                   | A      | B   | C        |  |        |
| (1)    | (2)        | (3)               | (4)    | (5) | (6)      |  |        |
| (i)    | Flat Back  | 660 x 460         | 660    | 460 | 200, Min |  |        |
|        |            | (Surgeon's basin) |        |     |          |  |        |
|        |            | 630 x 450         | 630    | 450 | 290, Max |  |        |
|        |            | 550 x 400         | 550    | 400 | 290, Max |  |        |
|        |            | 450 x 300         | 450    | 300 | 225, Max |  |        |
| (ii)   | Angle back | 600 x 480         | 600    | 480 | 290, Max |  |        |
|        |            | 400 x 400         | 400    | 400 | 290, Max |  |        |



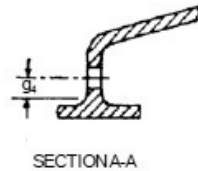
SECTION A-A



CONNECTING DIMENSIONS FOR SINGLE TAP HOLE WASH BASINS



CONNECTING DIMENSIONS OF WASH BASINS AND TWO TAP



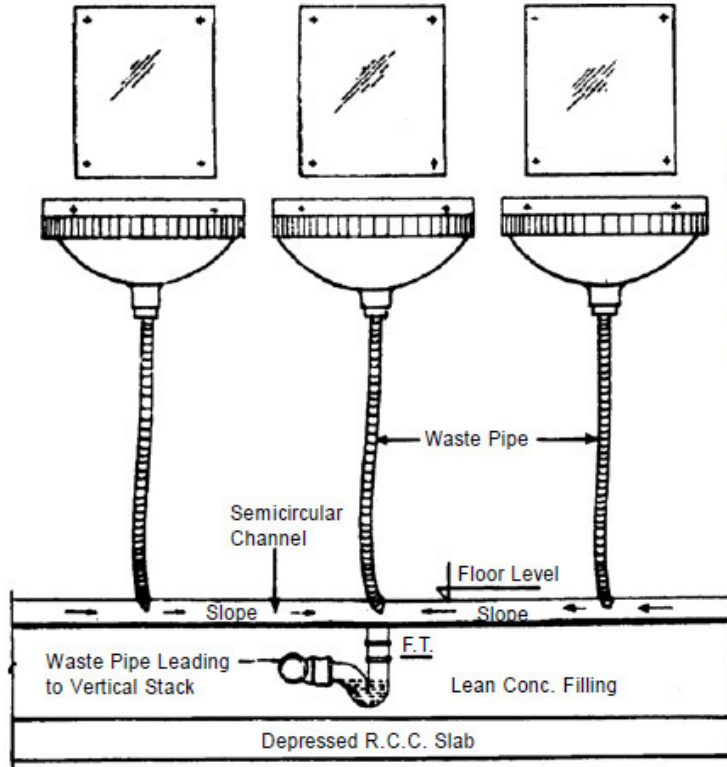
SECTION A-A

Drawing Not to Scale  
 All dimensions are in mm

**Fig. 17.14 : Wash Basins**

## FIXING ARRANGEMENT OF WASH BASIN (ELEVATION OF WASH BASIN)

**Sub Head : Sanitary Installations  
Clause : 17.1.14**

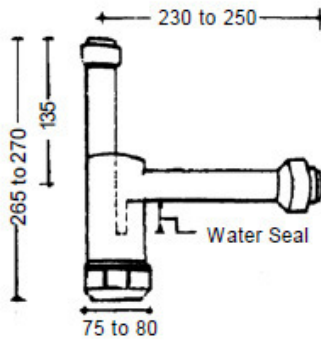


Location : General Offices Waste discharging in Semicircular open channel and collected in floor trap.

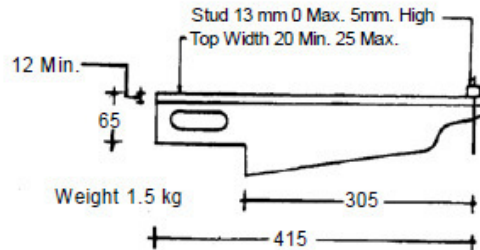
Notes:

- (1) Slope : 1 in 10 to 1 in 50.
- (2) F.T.: Ref. Q.C.T.A Circular No. 2 of 1992.
- (3) Waste Pipe : P.V.C. flexible Type (32 mm)
- (4) F.T. Location preferred in Centre to Achieve Max. Slope.
- (5) Water supply connection not shown.

TYPICAL ELEVATION OF 3 WASH BASINS IN A ROW



TYPICAL DETAIL OF BOTTLE TRAP



C.I. BRACKET

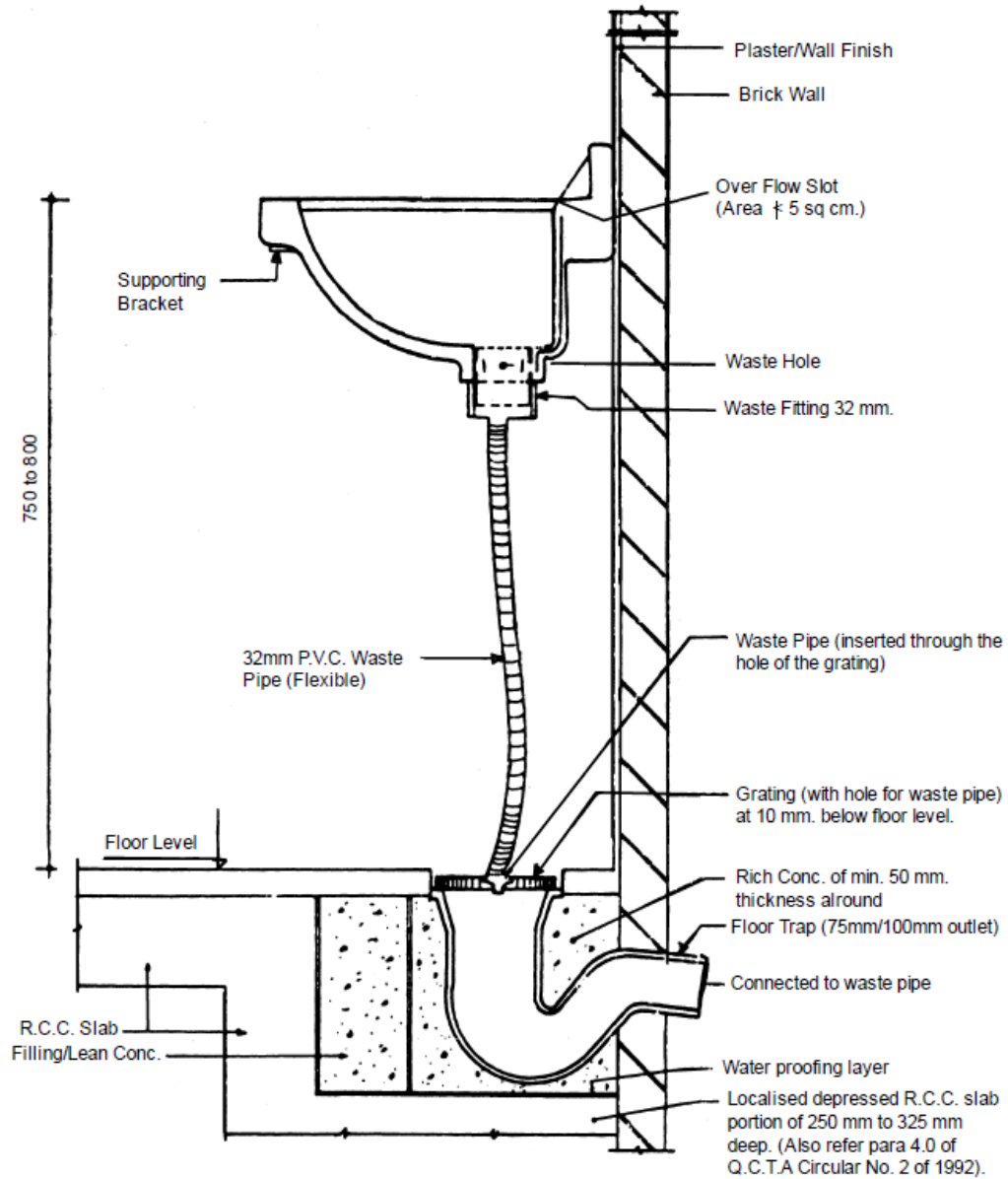
**Note :** Stud shall be provided for supports intended for glazed earthenware, vitreoware wash basins only.

Drawing Not to Scale  
All dimensions are in mm

**Fig. 17.15 : Fixing Arrangement of Wash Basin**

## TYPICAL VERTICAL SECTION OF WASH BASIN (WASTE PIPE OPEN TO VIEW)

**Sub Head : Sanitary Installations  
Clause : 17.1.14**

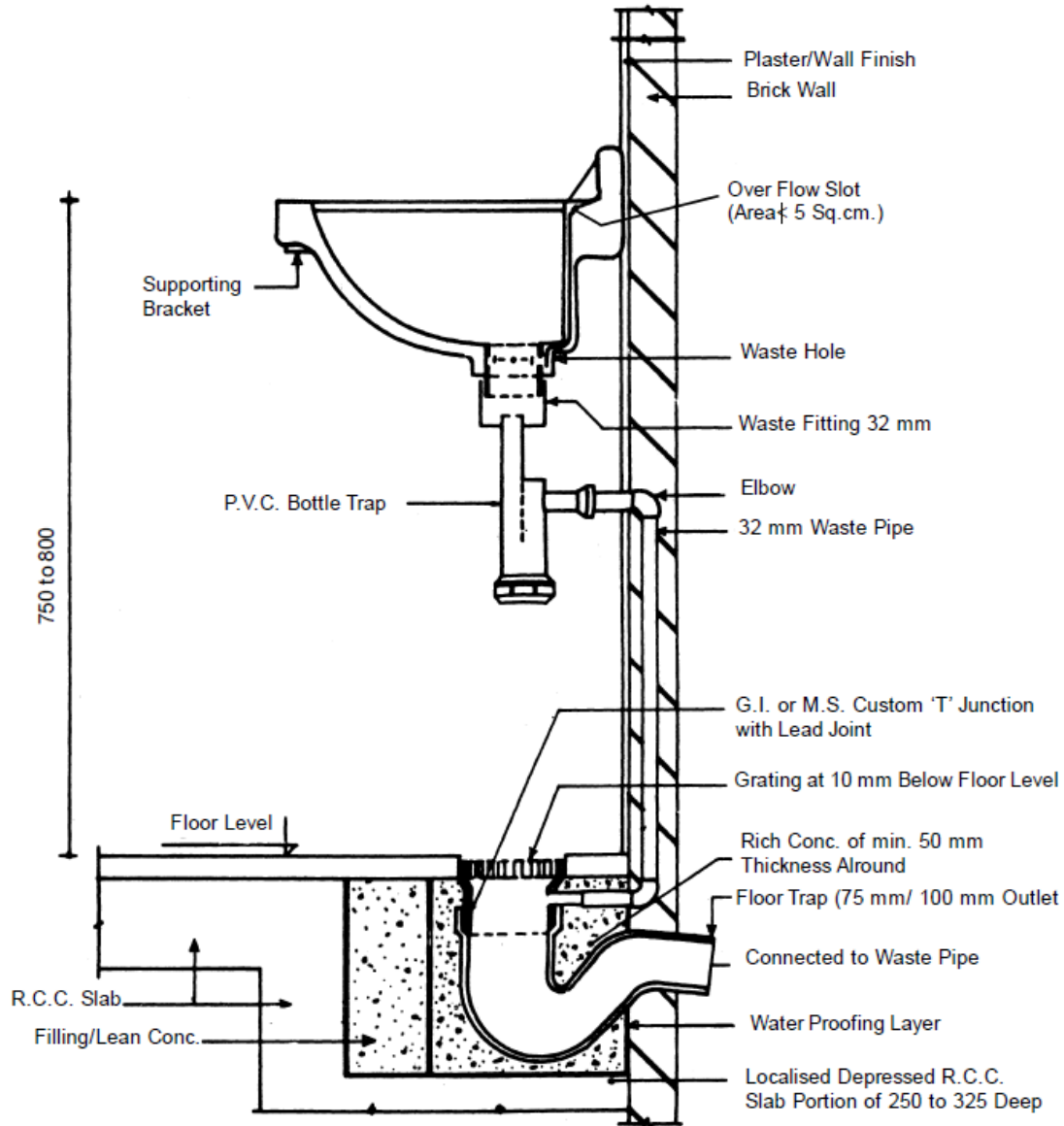


Drawing Not to Scale  
All dimensions are in mm

**Fig. 17.16 : Typical Vertical Section of Wash Basin (Waste Pipe Open to View)**

## TYPICAL VERTICAL SECTION OF WASH BASIN (WASTE PIPE CONCEALED FROM VIEW)

**Sub Head : Sanitary Installations  
Clause : 17.1.14**

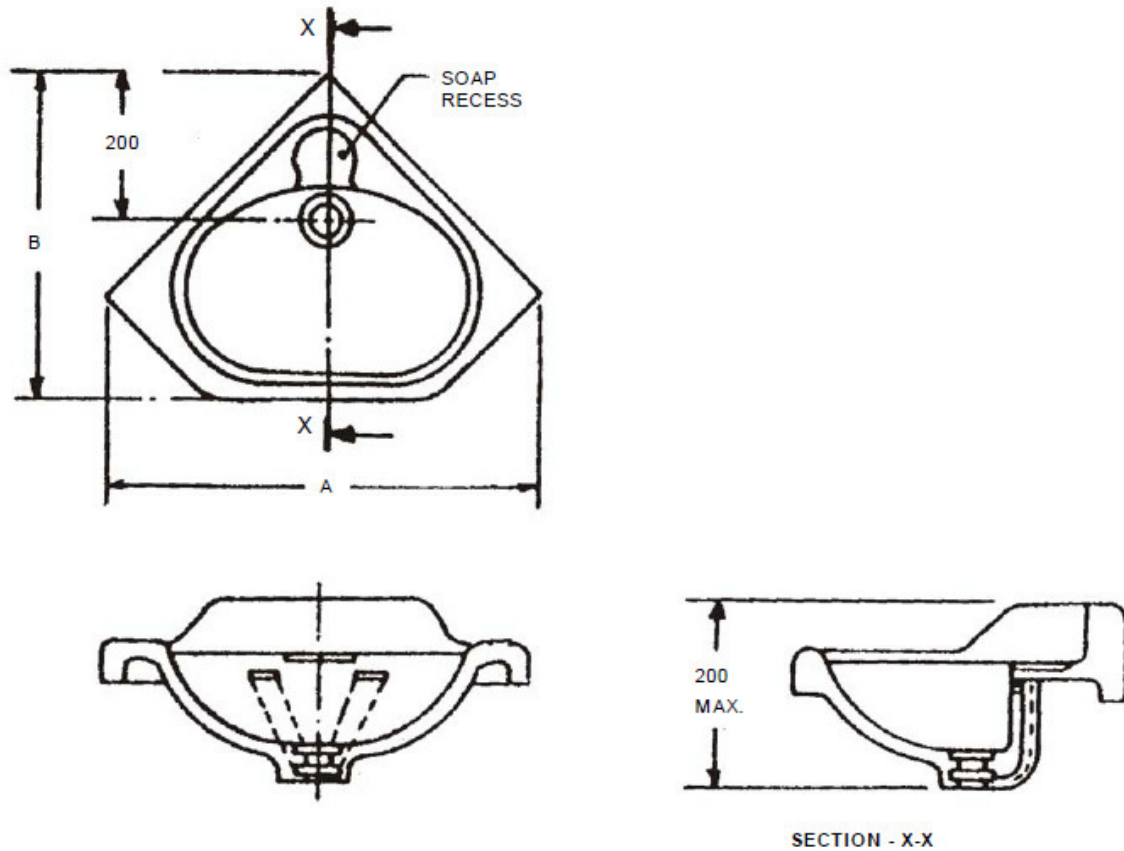


Drawing Not to Scale  
All dimensions are in mm

**Fig. 17.17 : Typical Vertical Section of Wash Basin (Waste Pipe Concealed from View)**

## ANGLE BACK WASH BASIN (PATTERN-2)

Sub Head : Sanitary Installations  
Clause : 17.1.14



### Notes :

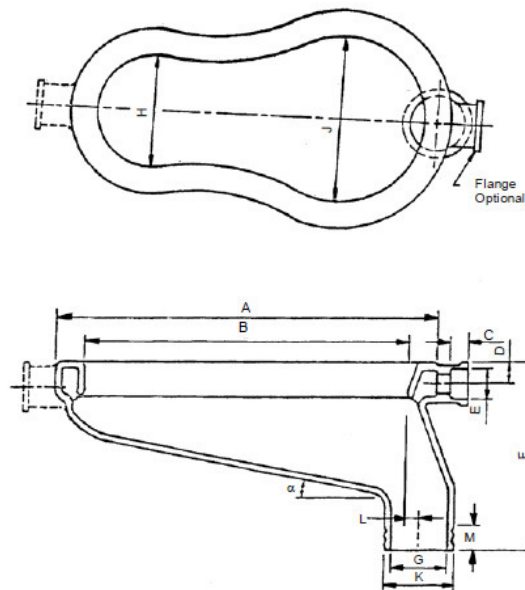
- (1) Tap hole provisions are not shown. However provision shall be made for 1 or 2 Tap holes in any suitable position.
- (2) Stud provisions are not shown but suitable provision shall be made for fixing purposes.
- (3) Provision of soap recess need not be central in the case of single tap hole.
- (4) Drawing not to scale.
- (5) All dimensions are in mm.

Fig. 17.18 : Angle Back Wash Basin (Pattern-2)

## LONG PATTERN SQUATTING PAN, TYPE I

Sub Head : Sanitary Installations

Clause : 17.1.16.1



Functional Dimensions of Long and Orissa Pattern  
All Dimensions in millimetres

| Sl. No. | Description  | Ref. in Fig. 19 and 20 | Long Pattern of Size |          | Orissa Pattern of Size |           |
|---------|--|------------------------|----------------------|----------|------------------------|-----------|
|         |  |                        | 580                  | 630      | 580 x 440              | 630 x 450 |
| (1)     | (2)  | (3)                    | (4)                  | (5)      | (6)                    | (7)       |
| (i)     | Length   | A                      | 580                  | 630      | 580                    | 630       |
| (ii)    | Length of opening, <i>Min</i>  | B                      | 480                  | 530      | 470                    | 500       |
| (iii)   | Height   | F                      | 300 ± 10             | 320 ± 10 | 300 ± 10               | 320 ± 10  |
| (iv)    | Width of opening, small end  | H                      | 170 ± 10             | 170 ± 10 | 180 ± 10               | 180 ± 10  |
| (v)     | Width of opening, wide end   | J                      | 260 ± 10             | 260 ± 10 | 210 ± 10               | 220 ± 10  |
| (vi)    | Slope of bottom of Pan   | $\alpha$               | 15°                  | 15°      | 15°                    | 15°       |
| (vii)   | Distance between the centre of outlet to the inside face of flushing rim at the back, <i>Max</i> | L                      | 70                   | 70       | 70                     | 70        |
| (viii)  | Width  | N                      | —                    | —        | 440                    | 450       |
| (ix)    | Length of foot rest  | P                      | —                    | —        | 310 ± 10               | 310 ± 10  |

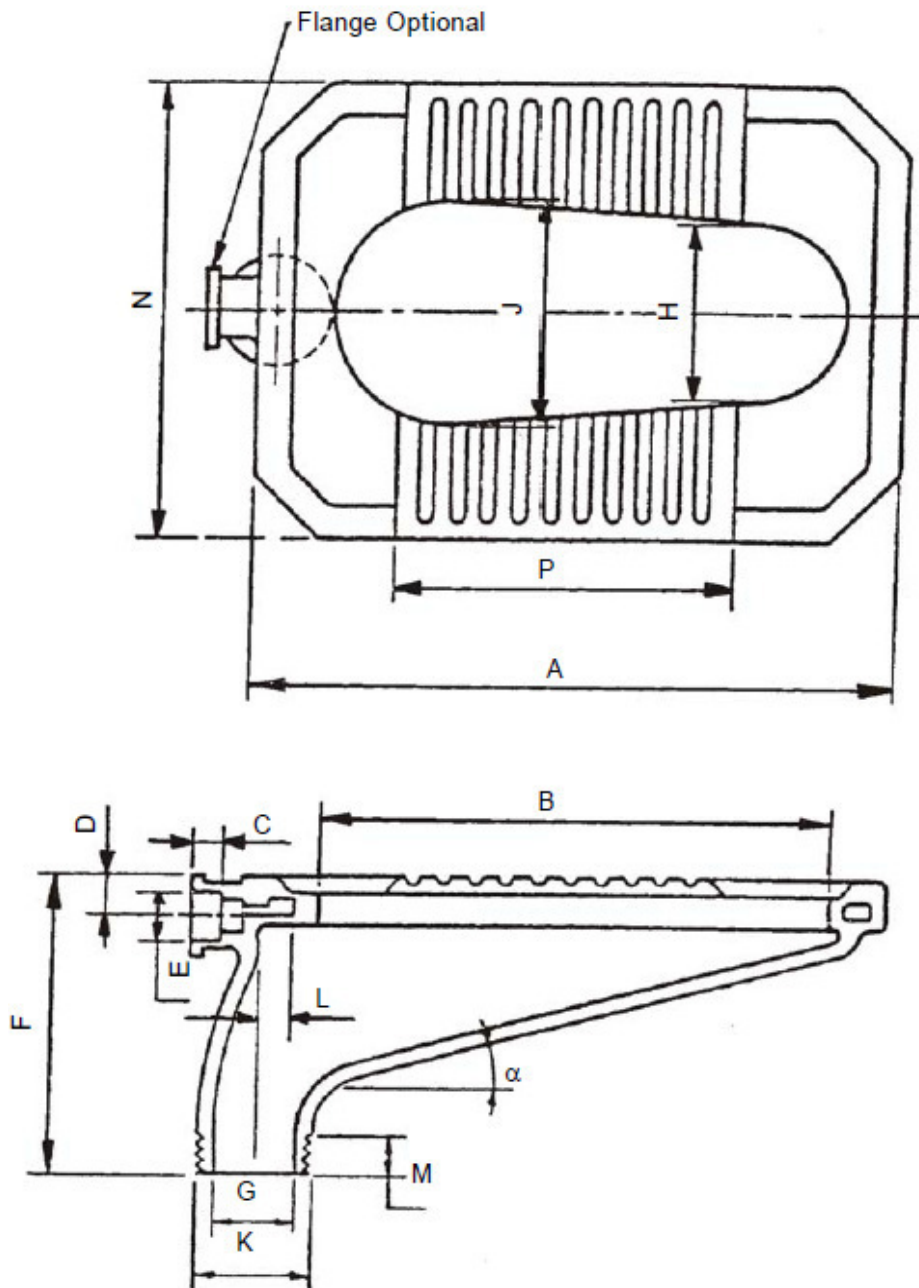
Note : Tolerances where not specified shall conform to Part I of IS-2556

Fig. 17.19 : Long Pattern Squatting Pan, Type I

## ORISSA PATTERN SQUATTING PAN

Sub Head : Sanitary Installations

Clause : 17.1.16.1



**Note :** Footrest may be flushed or raised, clearance permissible between raised footrest and rim opening.

All Dimensions in Millimetres.

**Fig. 17.20 : Orissa Pattern Squatting Pan**



# INTEGRATED SQUATTING PAN

Sub Head : Sanitary Installations  
Clause : 17.1.16.1

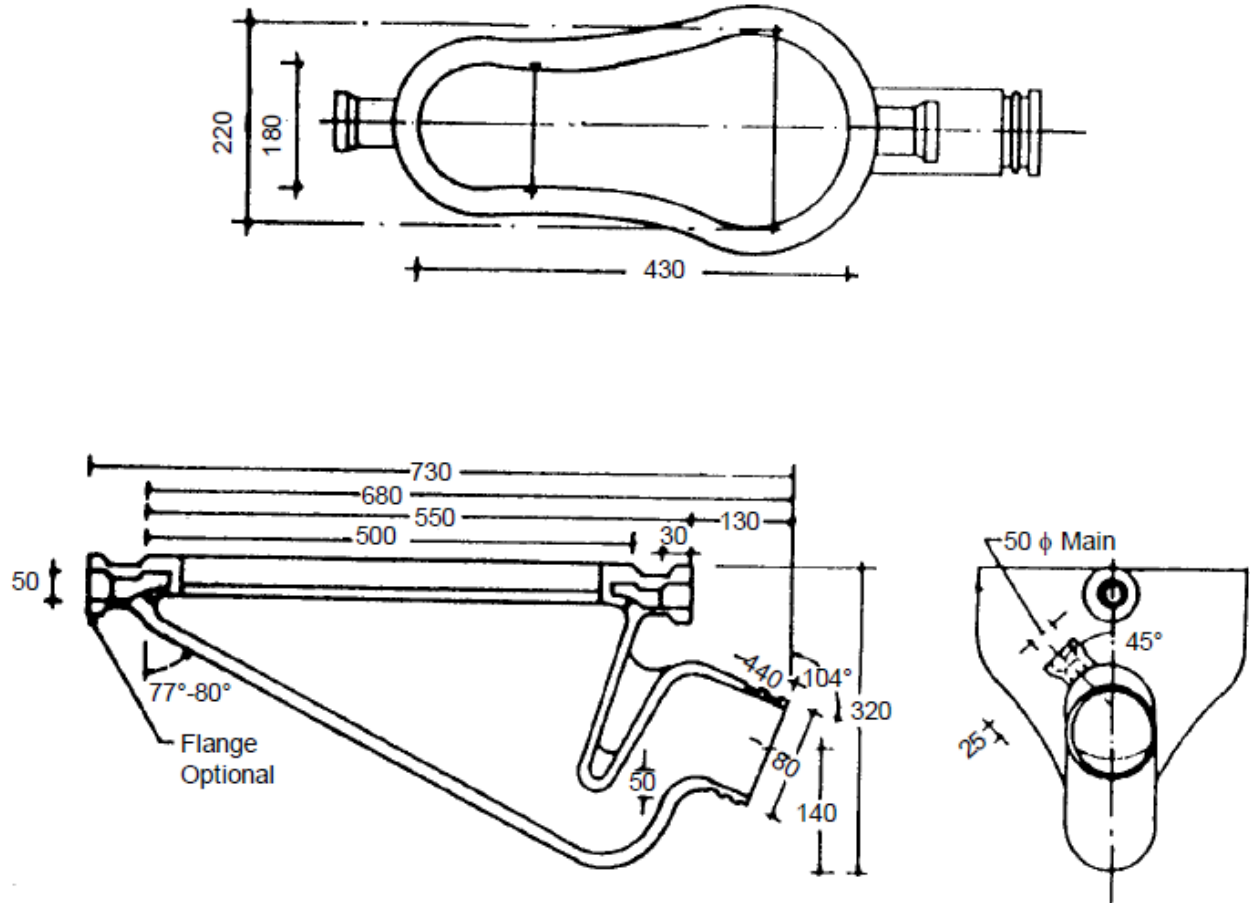
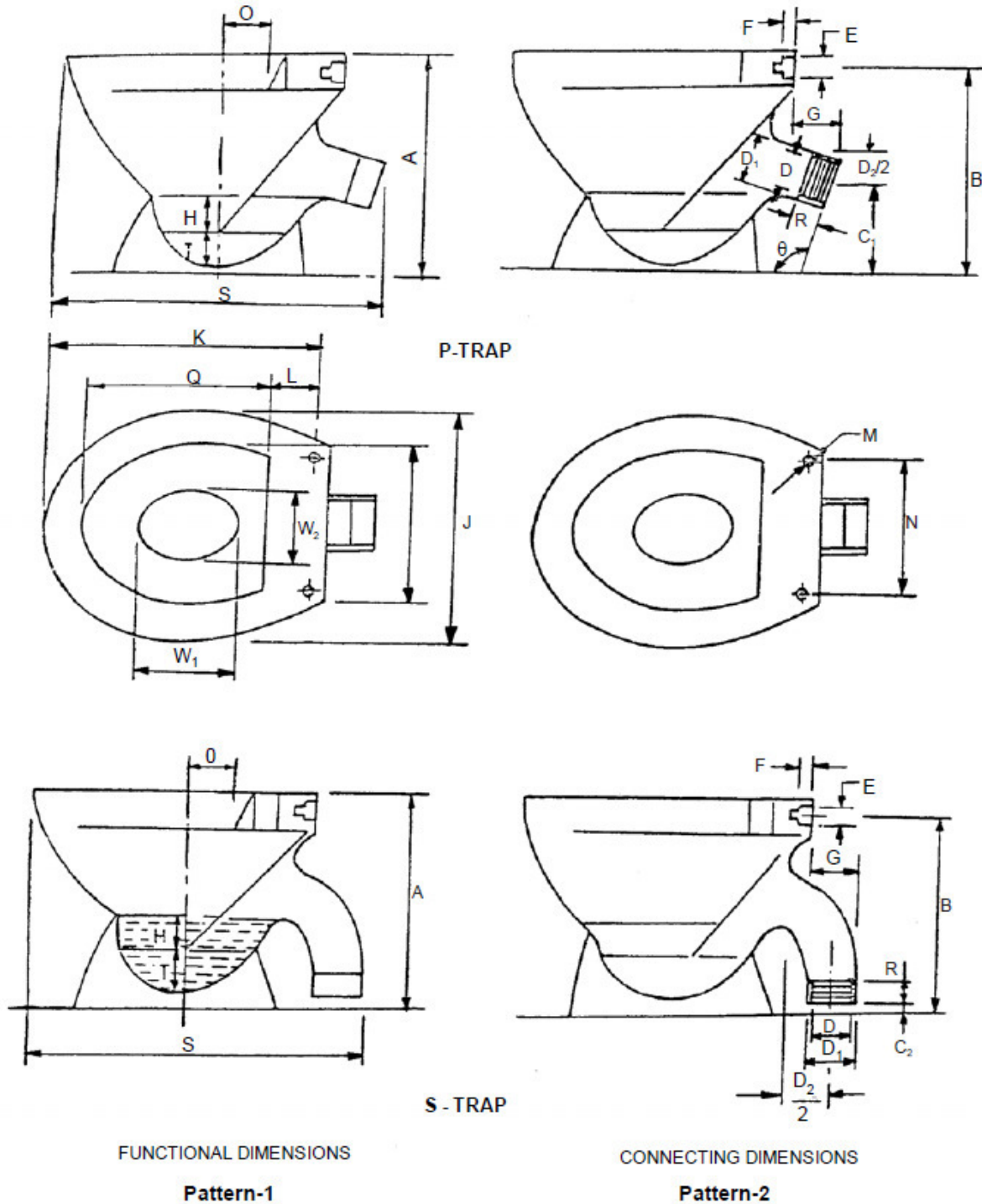


Fig. 17.21 : Integrated Squatting Pan



# PATTERN 1 AND PATTERN 2 WATER CLOSETS

Sub Head : Sanitary Installations  
 Clause : 17.1.16.2



All dimensions in millimetres

Fig. 17.22 : Pattern 1 and Pattern 2 Water Closets

## PATTERN 3 WATER CLOSET WITH HORIZONTAL P-TRAP

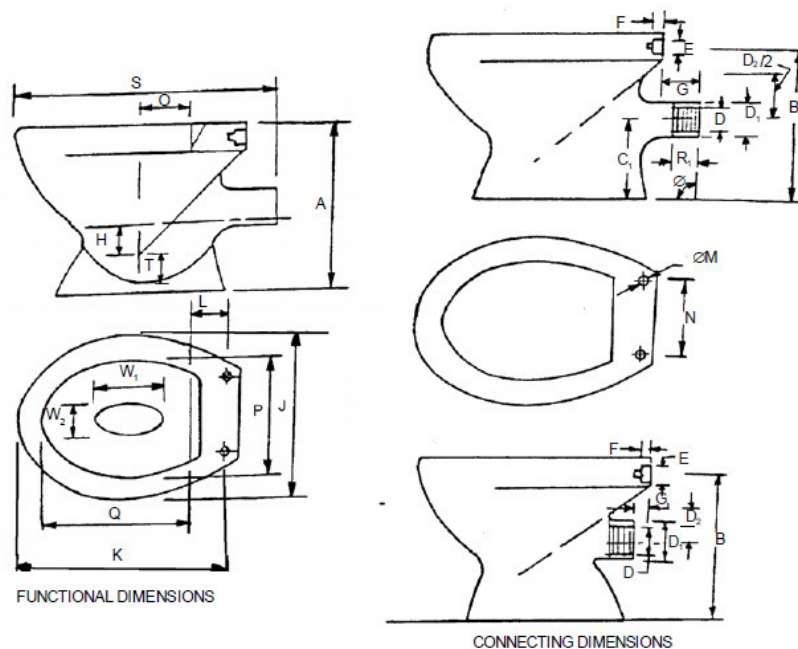
**Sub Head : Sanitary Installations**  
**Clause : 17.1.16.2**

### FUNCTIONAL DIMENSIONS

*All dimensions in millimetres*

| Sl.No. | Description   | Ref. in Fig.   | Pattern 1      | Pattern 2      | Pattern 3      |
|--------|---|----------------|----------------|----------------|----------------|
| (1)    | (2)   | (3)            | (4)            | (5)            | (6)            |
| (i)    | Height  | A              | 390 ± 10       | 390 ± 10       | 390 ± 10       |
| (ii)   | Depth of water seal, <i>Min</i>   | H              | 50             | 50             | 50             |
| (iii)  | Width of water closet   | J              | 380 ± 10       | 380 ± 10       | 380 ± 10       |
| (iv)   | Distance from centre of seat bolt hole to front of water closet   | K              | 415 to 445     | 415 to 445     | 415 to 445     |
| (v)    | Distance from centre of seat bolt hole to inside face of flush rim at back, <i>Max</i>                  | L              | 80             | 80             | 80             |
| (vi)   | Distance between a vertical line from tip of back plate to inside face of flush rim at back, <i>Max</i> | O              | 70             | 70             | 70             |
| (vii)  | Width of opening, <i>Min</i>  | P              | 240            | 240            | 240            |
| (viii) | Length of opening, <i>Min</i>   | Q              | 290            | 290            | 290            |
| (ix)   | Overall length  | S              | 500-575        | 500-575        | 500 <i>Max</i> |
| (x)    | Trap inlet depth, <i>Min</i>  | T              | 75             | 75             | 75             |
| (xi)   | Water surface   |                |                |                |                |
|        | Back to front   | W <sub>1</sub> | 150 <i>Min</i> | 100 <i>Min</i> | 150 <i>Min</i> |
|        | Side to side  | W <sub>2</sub> | 110 <i>Min</i> | 75 <i>Min</i>  | 110 <i>Min</i> |

**Note :** In case of centre vent in S Trap, overall length should be taken as S + 75.



All dimensions in millimetres

**Fig. 17.23 : Pattern-3 Water Closet with Horizontal P-Trap**

## TYPICAL COUPLING JOINT INSTALLATION

Sub Head : Sanitary Installations  
Clause : 17.1.8A

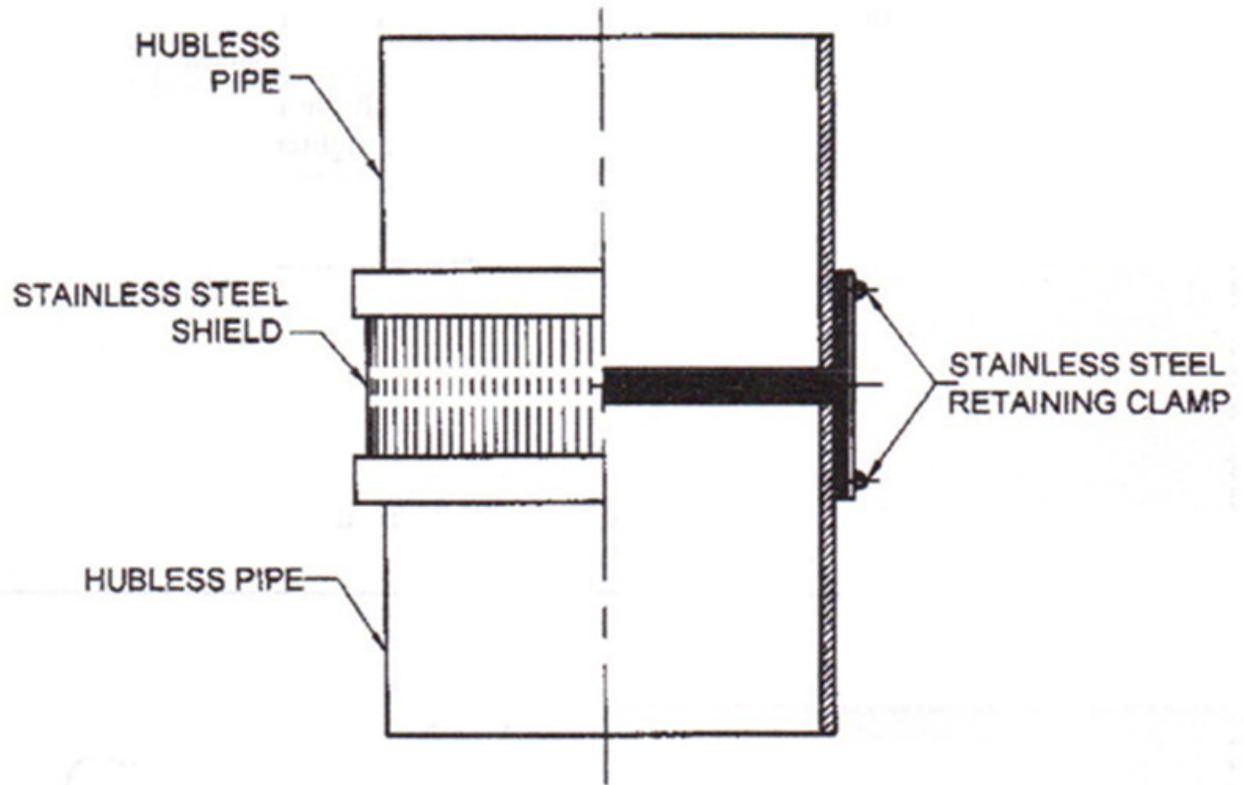


Fig. 17.24 Typical coupling joint-installation

**TYPICAL ILLUSTRATION OF WALL MOUNTED WATER CLOSET WITH CONCEALED  
OUTLET (PATTERN 1)**

Sub Head : 17.0 Sanitary Installations

Clause : 17.21.1

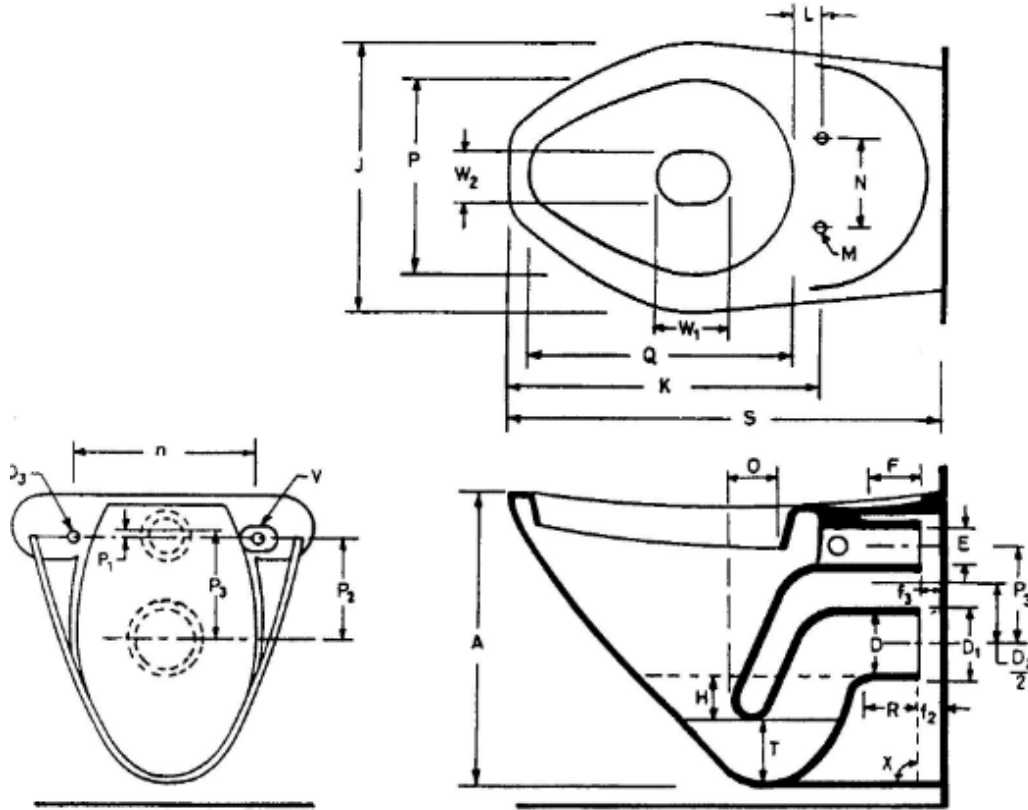


Fig 17.25 Typical illustration of wall mounted Water Closet with concealed outlet (Pattern 1)

TABLE-2

Connecting dimensions:

| SL.No | Description           | Reference to Fig 25 & Fig 26 | Pattern 1  | Pattern 2 |
|-------|-----------------------|------------------------------|------------|-----------|
| 1     | Internal Dia of Inlet | E                            | 55+3<br>-1 | 55±3      |

**TYPICAL ILLUSTRATION OF WATER CLOSET WITH FIXING ARRANGEMENT ON TOP OF BRACKET (PATTERN 2)**

Sub Head : 17.0 Sanitary Installations

Clause : 17.21.1

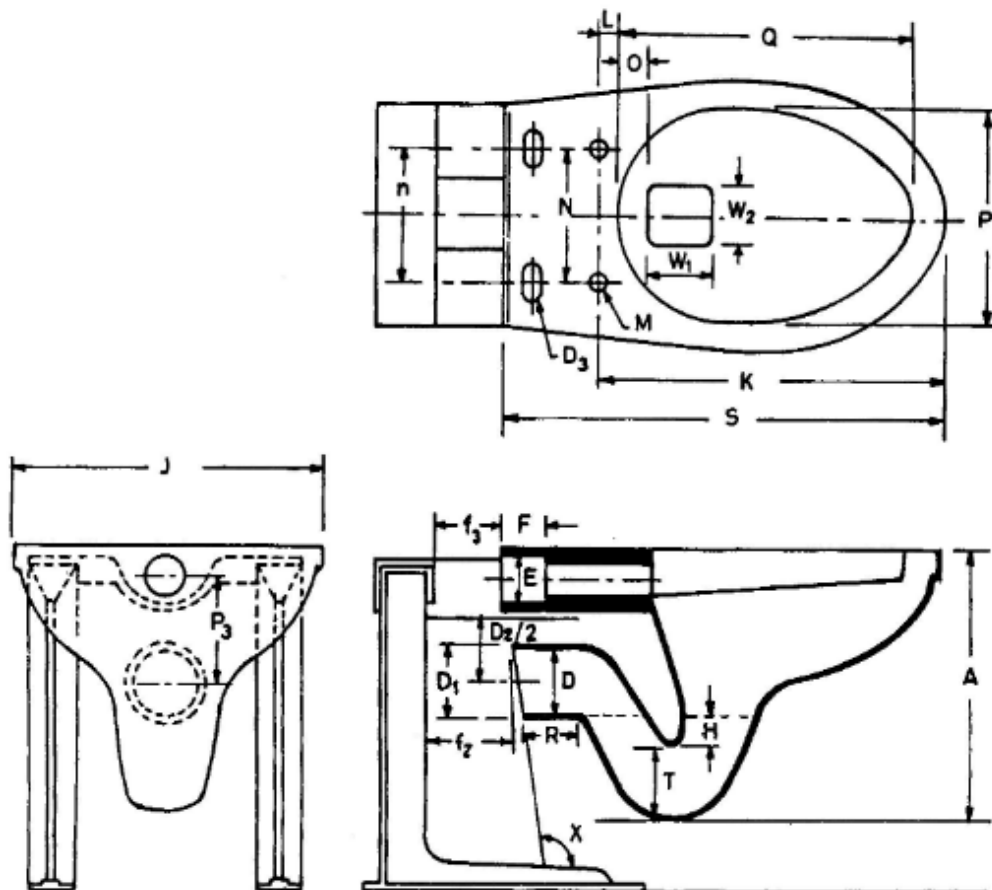


Fig 17.26 Typical illustration of water closet with fixing arrangement on top of bracket (pattern 2)

**SUB HEAD : 18.0**

**WATER SUPPLY**



## CONTENTS

| <i>Clause No.</i> | <i>Brief Description</i>                       | <i>Page No.</i> |
|-------------------|--|-----------------|
|                   | List of Bureau of Indian Standards (BIS) Codes | 947             |
| 18.1              | Terminology                                    | 949             |
| 18.2              | General Requirements                           | 950             |
| 18.3              | Materials                                      | 952             |
| 18.3.1            | Ball Valve (Brass)                             | 953             |
| 18.3.2            | Bib Taps and Stop Valve                        | 953             |
| 18.3.3            | Ferrules                                       | 954             |
| 18.3.4            | Fire Hydrants                                  | 954             |
| 18.3.5            | Gate Valve-Gun Metal                           | 954             |
| 18.3.6            | Pig Lead                                       | 954             |
| 18.3.7            | Lead Wool                                      | 954             |
| 18.3.8            | Non-return Valve-Gun Metal                     | 954             |
| 18.3.9            | Pipes and Specials                             | 954             |
| 18.3.10           | Pipes-Centrifugally Cast (Spun) Iron Pipes     | 955             |
| 18.3.11           | Pipes-Galvanized Iron                          | 955             |
| 18.3.12           | Shower Rose Brass                              | 956             |
| 18.3.13           | Sluice Valves-Brass/Gun Metal                  | 956             |
| 18.3.14           | Surface Box                                    | 956             |
| 18.3.15           | Water Meter (Domestic Type)                    | 956             |
| 18.3.16           | Yarn (Spun)                                    | 959             |
| 18.4              | Laying and Jointing of Pipes and Fittings      | 959             |
| 18.4.1            | Unloading                                      | 959             |



|        |   |     |
|--------|---|-----|
| 18.4.2 | Storing   | 959 |
| 18.4.3 | Cutting   | 959 |
| 18.4.4 | Trenches  | 960 |
| 18.4.5 | Laying  | 961 |
| 18.4.6 | Thrust Blocks   | 961 |
| 18.4.7 | Back Filling and Tamping  | 962 |
| 18.4.8 | Hydrostatic Tests   | 962 |
| 18.5   | Laying and Jointing of Cast Iron Pipes and Fittings (External Work) | 963 |
| 18.6   | Laying and Jointing of G.I. Pipes (External Work)                   | 966 |
| 18.7   | Laying and Jointing of G.I. Pipes (Internal Work)                   | 967 |
| 18.8   | Polypropylene Random Co-Polymer (PP-R) Pipes                        | 968 |
| 18.9   | Chlorinated Polyvinyl Chloride (CPVC) Pipes                         | 972 |
| 18.10  | PE-AL-PE Pipes  | 976 |
| 18.11  | Making Connection of G.I., Distribution Branch with G.I. (Main)     | 980 |
| 18.12  | Fixing Brass and Gun Metal Water Fittings                           | 981 |
| 18.13  | Fixing Ferrules   | 981 |
| 18.14  | Installation of Fire Hydrant  | 981 |
| 18.15  | Installation of Sluice Valve  | 981 |
| 18.16  | Installation of Water Meter and Stop Valve                          | 982 |
| 18.17  | Fixing Surface Box  | 982 |
| 18.18  | Polyethylene Water Storage Tanks                                    | 982 |
| 18.19  | Tube Wells with Hand Pumps  | 984 |

|            |  |     |
|------------|--|-----|
| 18.20      | Cutting Holes in Wall upto 30 x 30 cm                                  | 984 |
| 18.21      | Cutting Holes in R.C.C. Floors (upto 15 x 15 cm)                       | 984 |
| 18.22      | Cutting Chases in Masonry Walls  | 985 |
| 18.23      | CP Brass Bib Cock  | 986 |
| 18.24      | CP Brass Long Nose Bib Cock  | 986 |
| 18.25      | CP Brass Long Body Bib Cock  | 986 |
| 18.26      | CP Brass Stop Cock (Concealed)   | 986 |
| 18.27      | CP Brass Angle Valve   | 986 |
| 18.28      | CP Brass Extension Nipple  | 987 |
| 18.29      | PTMT Bib Cock  | 987 |
| 18.30      | PTMT Stop Cock   | 987 |
| 18.31      | PTMT Pillar Cock   | 987 |
| 18.32      | PTMT Push Cock   | 987 |
| 18.33      | PTMT Grating   | 987 |
| 18.34      | PTMT Ball Cock   | 987 |
| 18.35      | PTMT Angle Stop Cock   | 987 |
| 18.36      | PVC Connection Pipe  | 987 |
| 18.37      | PTMT Extension Nipple for Water Tank Pipe                              | 988 |
| 18.38      | Disinfecting C.I Water Mains by Flushing with Water                    | 988 |
| 18.39      | Chrome Plated Brass Battery based Infrared Sensor Operated Pillar Cock | 988 |
| Appendix A | Tolerances for Cast Iron (Centrifugally Cast) Pipes                    | 989 |
| Appendix B | Tolerances for Specials of Cast Iron Pipes                             | 990 |
| Appendix C | Particulars of Medium Grade G.I. Pipes                                 | 991 |

|            |  |      |
|------------|--|------|
| Appendix D | Procedure for Pressure Test  | 992  |
| Appendix E | Guidelines for Storage and Installation of CPVC Pipes                    | 993  |
| Appendix F | Sampling and Criteria for Conformity of CPVC Pipes                       | 994  |
| Fig. 18.1  | Ball Valve (Assembly)  | 999  |
| Fig. 18.2  | Fittings and Specials  | 1000 |
| Fig. 18.3  | Bib Tap & Stop Valve   | 1001 |
| Fig. 18.4  | Cocks Valves and Meter   | 1002 |
| Fig. 18.5  | Underground Fire Hydrant, Sluice-Valve Gate                              | 1003 |
| Fig. 18.6  | Masonry Chambers and Surface Boxes<br>(for Fire Hydrant and Water Meter) | 1004 |
| Fig. 18.7  | Masonry Chambers and Surface Boxes<br>(for Stop Cock and Sluice Valves)  | 1005 |
| Fig. 18.8  | Thrust Blocks  | 1006 |
| Fig. 18.9  | Hydrostatic Tests (End Closure for Pipes)                                | 1007 |

**LIST OF BUREAU OF INDIAN STANDARDS (BIS) CODES**

| <i>S. No.</i> | <i>BIS. No.</i>  | <i>Subject</i>  |
|---------------|------------------|---|
| 1             | IS 554           | Pipe threads where pressure tight joints are required on the threads- Dimensions, tolerances and designation.                                 |
| 2             | IS 778           | Specification for copper alloy gate, and check valves for water works purposes  |
| 3             | IS 779           | Water meters (domestic type) -Specification   |
| 4             | IS 14846         | Specification for sluice valves for water works purposes (50 to 1200 mm size)   |
| 5             | IS 781           | Specification for cast copper alloy screw down bib taps and stop valves for water services  |
| 6             | IS 782           | Specification for caulking lead   |
| 7             | IS 909           | Underground fire hydrant, sluice valve type-Specification   |
| 8             | IS 1239 (Part 1) | Steel tubes tubular and other wrought steel fittings, Part 1- Steel tubes- Specification  |
| 9             | IS 1239 (Part 2) | Specification for mild steel tubes tubular and other wrought steel fittings, Part 2-Mild street tubular and other wrought steel pipe fittings |
| 10            | IS 1536          | Centrifugally cast (spun) iron pressure pipes for water gas and sewage- Specification   |
| 11            | IS 1537          | Specification for vertically cast iron pressure pipes for water, gas and sewage   |
| 12            | IS 1538          | Cast iron fittings for pressure pipes for water, gas and sewage - Specification   |
| 13            | IS 1703          | Water fittings - copper alloy float valves (horizontal plunger type) - Specification  |
| 14            | IS 2692          | Ferrules for water services- Specification  |
| 15            | IS 3950          | Specification for surface boxes for sluice valves   |
| 16            | IS 4736          | Specification for Hot-dip Zinc Coatings on mild steel tubes   |
| 17            | IS 5312 (Part 1) | Swing type reflex (non return) valves for water works purposes. Part 1- Single door pattern   |
| 18            | IS 5312 (Part 2) | Swing type reflex (non return) valves for water works purposes. Part 2- Multi door pattern  |
| 19            | IS 5382          | Rubber sealing rings for gas mains, water mains and sewers  |
| 20            | IS 9762          | Specification for polyethylene floats (spherical) for float valves  |
| 21            | IS 9763          | Plastic Bib taps and stop valves (rising spindle) for cold water services- specifications   |
| 22            | IS 15450         | PE-AL-PE Pipes for hot and cold water supplies-Specifications   |

|    |          |  |
|----|----------|--|
| 23 | IS 15778 | Chlorinated Polyvinyl Chloride (CPVC) pipes for potable hot and cold water distribution supplies-specifications. |
| 24 | IS 15801 | Polypropylene- Random Copolymer Pipes for hot and cold water supplies-Specifications                             |
| 25 | IS 2685  | Code for selection/Installation and Maintenance of Sluice Valve  |

## 18.0 WATER SUPPLY

### 18.1 TERMINOLOGY

**Air Gap:** The unobstructed vertical distance through the free atmosphere between the lowest opening from any pipe or fitting supplying water to a tank or other device and the flood level rim of the receptacle in a water supply system.

**Air Valve:** A valve that releases air from a pipe line automatically without loss of water, or introduces air into a pipe line automatically if the internal pressure becomes less than that of the atmosphere.

**Available Head:** The head of water available at the point of consideration due to main's pressure or overhead tank or any other source of pressure.

**Back Flow:** The flow of water into the distributing pipes of water system from any source or sources other than its intended source.

**Back Siphonage:** The flowing back of used, contaminated or polluted water from a plumbing fitting or vessel into a water supply system due to a lowering of pressure in such system.

**Ball Cock (Fig. 18.1):** A faucet opened or closed by the fall or rise of a ball floating on the surface of water.

**Branch (Fig. 18.2):** (i) A special form of cast iron pipe used for making connections to water mains. The various types are called T, Y, T-Y, double Y, and V branches, according to their respective shapes.

(ii) Any part of a piping system other than a main.

**Capacity:** The storage capacity of storage or flushing cistern or a tank when filled up to the water line.

**Non Return Valve (Fig. 18.4):** A device provided with a disc hinged on one edge so that it opens in the direction of normal flow and closes with reversal of flow.

**Collar:** A pipe fitting in the form of a sleeve for jointing the spigot ends of two pipes in the same alignment.

**Coupling:** A pipe fitting with inside threads only, used for connecting two pieces of pipe.

**Cross (Fig. 18.2):** A pipe fitting used for connecting four pipes at right angles.

**Elbow (Fig. 18.2):** A pipe fitting for providing a sharp change of direction in a pipe line.

**Ferrule (Fig. 18.2):** A pipe fitting for connecting a service pipe to a water main.

**Fitting:** Anything fitted or fixed in connection with the supply, measurement, control, distribution, utilization or disposal of water.

**Fire Hydrant (Fig. 18.5):** A device connected to a water main and provided with necessary valve and outlets, to which a fire hose may be attached for discharging water at a high rate for the purpose of extinguishing fires, washing down streets, or flushing out the water main.

**Flange (Fig. 18.2):** A projecting flat rim on the end of a valve, pipe etc.

**Flanged Pipe (Fig. 18.2):** A pipe provided with flanges so that the ends can be joined together by means of bolts.

**Float Valve:** A valve in which the closure to an opening such as a plug or gate is actuated by a float to control the flow into a tank.

**Sluice Valve (Gate Valve) (Fig. 18.4) :** A valve in which the flow of water is cut off by means of a circular disc., fitting against machine-smoothed faces, at right angles to the direction of flow. The disc is raised or lowered by means of a threaded stem connected to the handle of the valve; the opening in the valve is usually as large as the full bore of the pipe.

**Nipple (Fig. 18.2):** A tubular pipe fitting usually threaded on both ends and less than 300 mm long used for connecting pipes or fittings.

**Offset:** A combination of elbows or bends which brings one section of the pipe out of line but into a line parallel with the other section in a piping system.

**Reflux Valve (Fig. 18.4):** A non return valve used in a pipe line at a rising gradient to prevent water that is ascending the gradient from flowing back in the event of a burst lower down.

**Socket (Fig. 18.2):** The female part of the spigot and socket joint.

**Spigot (Fig. 18.2):** The male part of a spigot and socket joint.

**Stop Cock (Fig. 18.3):** A control valve fixed at the end of a communication pipe which controls the supply from the water main.

**Storage Tank:** A tank or a cistern for storage of water which is connected to the water main by means of a supply pipe.

**Service or Supply Pipe:** Pipe through which supply is drawn from water mains.

**Union (Fig. 18.2):** A pipe fitting used for joining the ends of two pipes neither of which can be turned.

**Valve:** A device used for controlling the flow of water in a pipe line.

## **18.2 GENERAL REQUIREMENTS**

**18.2.1** Any damage caused to the building, or to electric, sanitary water supply or other installations etc. therein either due to negligence on the part of the contractor, or due to actual requirements of the work, shall be made good and the building or the installations shall be restored to its original condition by the contractor. Nothing extra shall be paid for it, except where otherwise specified.

**18.2.2** All water supply installation work shall be carried out through licensed plumbers.

**18.2.3** It is most important to ensure that wholesome water supply provided for drinking and culinary purposes, is in no way liable to contamination from any less satisfactory water. There shall, therefore, be no cross connection whatsoever between a pipe or fitting for conveying or containing wholesome water and a pipe or fitting for conveying or containing impure water or water liable to contamination or of uncertain quality of water which has been used for any purpose. The provision of reflux or non-return valves or closed and sealed valves shall not be construed a permissible substitute for complete absence of cross-connection.

**18.2.4** Where a supply of wholesome water is required as an alternative or standby to supply of less satisfactory water or is required to be mixed with the latter, it shall be delivered only into a cistern, and by a pipe or fitting discharging into the air gap at a height above the top edge of the cistern equal to twice its nominal bore, and in no case less than 15 cm.

**18.2.5** No piping shall be laid or fixed so as to pass into, through or adjoining any sewer, scour outlet or drain or any manhole connected therewith nor through any ash pit or manure-pit or any material of such nature that can cause undue deterioration of the pipe.

**18.2.6** Where the laying of any pipe through fouled soil or previous material is unavoidable, the piping shall be properly protected from contact with such soil or material by being carried through an exterior cast iron tube or by some other suitable means. Any piping or fitting laid or fixed which does not comply with the above requirements, shall be removed and re-laid in conformity with the above requirements.

**18.2.7** The design of the pipe work shall be such that there is no possibility of backflow towards the source of supply from any cistern or appliance whether by siphonage or otherwise, and reflux or non-return valves shall not be relied upon to prevent such back flow.

**18.2.8** All pipe work shall be so designed, laid or fixed, and maintained so that it remains completely watertight, thereby avoiding wastage of water, damage to property and the risk of contamination of the water conveyed.

**18.2.9** In designing and planning the layout of the pipe work, due attention shall be given to the maximum rate of discharge, required economy in labour and materials, protection against damage and corrosion, protection from frost, if required, and to avoidance of airlocks, noise transmission and unsightly arrangement.

**18.2.10** To reduce frictional losses, piping shall be as smooth as possible inside. Methods of jointing shall be such as to avoid internal roughness and projection at the joints, whether of the jointing materials or otherwise.

**18.2.11** Change in diameter and in direction shall preferably be gradual rather than abrupt to avoid undue loss of head. No bend or curve in piping shall be made so as to materially reduce or alter the cross-section.

**18.2.12** Underground piping shall be laid at such a depth that it is unlikely to be damaged by frost or traffic loads and vibrations. It shall not be laid in ground liable to subsidence, but where such ground cannot be avoided; special precautions shall be taken to avoid damage to the piping. Where piping has to be laid across recently disturbed ground, the ground shall be thoroughly consolidated so as to provide a continuous and even support.

**18.2.13** Where the service pipe is of diameter less than 50 mm the stop valves shall be of the screw-down type and shall have loose washer plates to act as non-return valves. Other stop valves in the service line may be of the gate type.

**18.2.14** In flats and tenements supplied by a common service pipe a stop valve shall be fixed to control the each branch separately. In large buildings a sufficient number of stop valves shall be fixed on branch pipes, and to control groups of ball valves and draw off taps, so as to minimize interruption of the supply during repairs, all such stop valves shall be fixed in accessible positions and properly protected from being tampered with, they may be of the gate type to minimize loss of head by friction.



**18.2.15** Water for drinking or for culinary purposes as far as possible shall be on branch pipes connected directly to the service pipe.

**18.2.16** Pumps shall not be allowed on the service pipe as they cause a drop of pressure on the suction side thereby affecting the supply to the adjoining properties. In cases where pumping is required, a properly protected storage tank of adequate capacity shall be provided to feed the pump.

**18.2.17** Service pipes shall be so designed and constructed as to avoid air-locks, so that all piping and fittings above ground can be completely emptied of water to facilitate repairs. There shall be draining taps or draw-off taps (not underground) at the lowest points, from which the piping shall rise continuously to draw-off taps, ball valves, cisterns, or vents (where provided at the high points).

**18.2.18** Service pipes shall be designed so as to reduce the production and transmission of noise as much as possible. Appliances which create noise shall be installed as far distant as possible from the living rooms of the house. High velocity of water in piping and fittings shall be avoided. Piping shall be confined, as far as possible, to rooms where appliances are fixed, it shall have easy bends, and where quietness is particularly desired, holder bats or clamps shall be insulated from the piping by suitable pads.

**18.2.19** The rising pipe to the storage cistern, if any, or to any feed cistern shall be taken as directly as possible to the cistern and shall be fixed away from windows or ventilators.

**18.2.20** All pipe work shall be planned so that the piping is accessible for inspection, replacement and repair. To avoid its being unsightly, it is usually possible to arrange it in or adjacent to cupboards, recesses, etc. provided there is sufficient space to work on the piping with the usual tools. Piping shall not be buried in walls or solid floors. Where unavoidable, piping may be buried for short distances provided that adequate protection is given against damage and that no joints are buried. If piping is laid in ducts or chases, these shall be roomy enough to facilitate repairs and shall be so constructed as to prevent the entry of vermin. To facilitate removal of pipe casing, floor boards covering piping shall be fixed with screws or bolts.

**18.2.21** When it is necessary for a pipe to pass through a wall or floor, a sleeve shall be fixed therein for insertion of the pipe and to allow freedom for expansion, contraction and other movement. Piping laid in wood floors shall, where possible, be parallel with the joists.

**18.2.22** Where storage tanks are provided to meet overall requirements of water connection of service pipe with any distributing pipe shall not be permitted except one direct connection for culinary or drinking requirements.

**18.2.23** No service pipe shall be connected to any water closet or urinal. All such supplies shall be from flushing cisterns which shall have supply from storage tank.

**18.2.24** No service or supply pipe shall be connected directly to any hot-water system or to any apparatus used for heating other than through a feed cistern thereof.

### **18.3 MATERIALS**

**18.3.0** The standard size of brass or gun metal fittings shall be designated by the nominal bore of the pipe outlet to which the fittings are attached. A sample of each kind of fittings shall be got approved from the Engineer-in-Charge and all supplies made according to the approved samples.

All cast iron fittings shall be sound and free from laps, blow holes and pitting. Both internal and external surfaces shall be clean, smooth and free from sand etc. Burning, plugging, stopping or

patching of the casting shall not be permissible. The bodies, bonnets, spindles and other parts shall be truly machined so that when assembled the parts shall be axial, parallel and cylindrical with surfaces smoothly finished. The area of the water way of the fittings shall not be less than area of the nominal bore, chromium plating wherever specified shall be of 0.3 micron. The chromium shall never be deposited on brass unless a heavy coating of nickel is interposed. In the case of iron a thick coat of copper shall first be applied, then one of nickel and finally the chromium. In finish and appearance the plated articles when inspected shall be free from plating defects such as blisters, pits roughness and unplated areas and shall not be stained or discoloured. Before fitting is plated, the washer plate shall be removed from the fittings, the gland packing shall be protected from the plating solution.

### 18.3.1 Ball Valve (Brass)

The ball valve shall be of Brass or Gunmetal as specified conforming to IS 1703 (Fig. 18.1). The ball valve shall be of following two classes:—

- (a) **High Pressure:** High pressure float valves are indicated by the abbreviation 'HP' and are designed for use on mains having pressure of 0.175 MPa or above.
- (b) **Low Pressure:** Low Pressure float valves are indicated by the abbreviation 'LP' and are designed for use on mains having a pressure up to. 0.175 MPa.

The ball valves shall be of following nominal sizes 15 mm, 20 mm, 25 mm, 32 mm, 40 mm and 50 mm. The nominal size shall correspond with the nominal bore of the inlet shanks. Polyethylene floats shall conform to IS 9762.

### 18.3.2 Bib Taps and Stop Valve

Brass (Fig. 18.3): A bib tap is a draw off tap with a horizontal inlet and free outlet and a stop valve is a valve with suitable means of connections for insertion in a pipe line for controlling or stopping the flow. They shall be of specified size and shall be of screw down type and shall conform to IS 781. The closing device shall work by means of disc carrying a renewable non-metallic washer which shuts against water pressure on a seating at right angles to the axis of the threaded spindle which operates it. The handle shall be either crutch or butterfly type securely fixed to the spindle. Valve shall be of the loose leather seated pattern. The cocks (taps) shall open in anti-clock wise direction.

The bib tap and stop valve shall be polished bright. The minimum finished weights of bib tap and stop valve shall be as specified in Table 18.1.

**TABLE 18.1**  
**Minimum Finished Mass of Bib Taps and Stop Valves**

| Size | Minimum Finished Mass |                     |                     |           |
|------|-----------------------|---------------------|---------------------|-----------|
|      | Bib Taps              | Internally Threaded | Externally Threaded | Mixed End |
| (1)  | (2)                   | (3)                 | (4)                 | (5)       |
| mm   | kg                    | kg                  | kg                  | kg        |
| 8    | 0.250                 | 0.220               | 0.250               | 0.235     |
| 10   | 0.300                 | 0.300               | 0.350               | 0.325     |
| 15   | 0.400                 | 0.330               | 0.400               | 0.365     |
| 20   | 0.750                 | 0.675               | 0.750               | 0.710     |
| 25   | 1.250                 | 1.180               | 1.300               | 1.250     |
| 32   | --                    | 1.680               | 1.800               | 1.750     |
| 40   | --                    | 2.090               | 2.250               | 2.170     |
| 50   | --                    | 3.700               | 3.850               | 3.750     |

In case these are required to be nickel plated, the plating shall be of the first quality with a good thick deposit of silvery whiteness capable of taking high polish which will not easily tarnish or scale.

### 18.3.3 Ferrules (Fig. 18.2)

The ferrules for connection with C.I. main shall generally conform to IS 2692. It shall be of non ferrous materials with a C.I. bell mouth cover and shall be of nominal bore as specified. The ferrule shall be fitted with a screw and plug or valve capable of completely shutting off the water supply to the communication pipe, if and when required.

### 18.3.4 Fire Hydrants (Fig. 18.5)

The hydrant shall conform to IS 909 and shall consist of the following components:

|     |         |     |             |     |                  |
|-----|---------|-----|-------------|-----|------------------|
| (a) | Body    | (d) | Gland       | (g) | Valve            |
| (b) | Bonnet  | (e) | Spindle Cap | (h) | Screwed Outlet   |
| (c) | Spindle | (f) | Spindle Nut | (i) | Outlet and Chain |

The body, bonnet, gland, outlet cap and spindle cap and shall be of good quality cast iron grade FG 200 of IS 210. Outlet, seat for valve, valve, spindle nut, check nut shall be made of copper alloy as per IS 909.

### 18.3.5 Gate Valve - Gun Metal (Fig. 18.5)

These shall be of the gun metal fitted with wheel and shall be of gate valve type opening full way and of the size as specified. These shall generally conform to IS 778.

### 18.3.6 Pig Lead

Pig lead shall be of uniform quality, clean and free from foreign materials. It shall be of uniform softness and capable of being easily caulked or driven. It shall conform to IS 782 for caulking lead in all respects.

### 18.3.7 Lead Wool

Lead wool shall conform to IS 782 in all respects. Lead wool shall consist of fine strands or plated ribbons of lead. The cross-section of the individual strands shall be flat. The dimensions in the sectional plane shall not be less than 0.13 mm and not more than 0.90 mm and the rope shall be supplied in minimum lengths of two metres and the maximum length in any one package shall be such that the package does not weigh more than 50 Kg.

### 18.3.8 Non-Return Valve (Gun Metal) (Fig. 18.4)

A non- return valve permits water to flow in one direction only and is provided on the ascending part of the main to check return flow. The non-return valve shall be of Gun metal and shall be of horizontal or vertical flow type as specified.

The valve shall be of quality approved by the Engineer-in-Charge and shall generally conform to IS 778.

### 18.3.9 Pipes and Specials

Pipes and specials may be of any of the following types as specified:

- (a) Cast iron centrifugally cast (spun) – IS 1536
- (b) Galvanised steel – IS 1239 & IS 4736
- (c) PE-AL-PE Pipes – IS 15450
- (d) PP-R Pipes – IS 15801
- (e) CPVC pipes – IS 15778

In choosing the material for piping and fittings, account shall be taken of the character of the water to be conveyed through it, the nature of the ground in which the pipes are to be laid and the relative economics.

### 18.3.10 Pipes- Centrifugally Cast (Spun) Iron Pipes

**18.3.10.1** The spun iron pipes shall conform to IS 1536. The spun iron pipes shall be of cast iron cast centrifugally and vary in diameters from 80 mm to 750 mm. These shall be of class LA, class A and class B, as specified. Pipes shall be tested hydrostatically at the pressure specified in table 18.2 & 18.3. Tolerances on specified dimensions shall be as prescribed in Appendix A.

**18.3.10.2 Specials:** The specials shall conform to IS 1538. The hydraulic test pressure of each class shall be as detailed in Table 18.4. Tolerances on specified dimensions shall be as prescribed in Appendix B of sub head- 18.

**TABLE 18.2**

| <i>Hydrostatic Test pressure for centrifugally cast socket &amp; spigot pipes in MPa</i> |                     |                           |
|--|---------------------|---------------------------|
| <i>Hydrostatic Test pressure for works in MPa</i>  |                     |                           |
| <i>Class</i>   | <i>Up to DN 600</i> | <i>DN 700 &amp; above</i> |
| LA   | 3.5                 | 1.5                       |
| A  | 3.5                 | 2.0                       |
| B  | 3.5                 | 2.5                       |

**TABLE 18.3**

| <i>Hydrostatic Test pressure for centrifugally cast pipes with screwed on flanges in MPa</i> |                     |                           |
|--|---------------------|---------------------------|
| <i>Class</i>   | <i>Up to DN 600</i> | <i>DN 700 &amp; above</i> |
| B  | 2.5                 | 1.6                       |

**TABLE 18.4**

| <i>Hydrostatic Test pressure for fittings in MPa (N/mm<sup>2</sup>) (metre head)</i> |  |  |
|--|--|--|
| <i>Nominal - Diameter</i>  | <i>Fitting without branches or with branches not greater than half the principle diameter.</i> | <i>Fitting with Branches greater than half the Principal Diameter.</i> |
| Up to and including 300 mm   | 2.5 (25)   | 2.5 (25)   |
| Over 300 mm and up to and including 600 mm   | 2.0 (20)   | 2.0 (20)   |
| Over 600 mm and up to and including 1500 mm  | 1.5 (15)   | 1.0 (10)   |

### 18.3.11 Pipes-Galvanised Iron

**18.3.11.1** The pipes (tubes) shall be galvanised mild steel hot finished seamless (HFS) or welded (ERW) HRIW or HFW screwed and socketed conforming to the requirements of IS 1239 Part-I for medium grade. They shall be of the diameter (nominal bore) specified in the description of the item, the sockets shall be designated by the respective nominal bores of the pipes for which they are intended.

**18.3.11.2 Galvanising shall conform to IS 4736 :** The zinc coating shall be uniform adherent, reasonably smooth and free from such imperfections as flux, ash and dross inclusions, bare patches, black spots, pimples, lumping runs, rust stains, bulky white deposits and blisters. The pipes and sockets shall be cleanly finished, well galvanised in and out and free from cracks, surface flaws laminations and other defects. All screw threads shall be clean and well cut. The ends shall be cut cleanly and square with the axis of the tube.

**18.3.11.3** The dimensions and weights of pipes and sockets and tolerances shall be as prescribed in Appendix 'C'.

**18.3.11.4** All screwed tubes and sockets shall have pipe threads conforming to the requirements of IS 554. Screwed tubes shall have taper threads while the sockets shall have parallel threads.

**18.3.11.5** All tubes shall withstand a test pressure of 50 Kg/sq.cm without showing defects of any kind.

**18.3.11.6 Fittings :** The fittings shall be of mild steel tubular or wrought steel fittings conforming to IS 1239 (Part-2) or as specified. The fittings shall be designated by the respective nominal bores of the pipes for which they are intended.

#### **18.3.12 Shower Rose Brass**

The shower rose shall be of chromium plated brass of specified diameter. It shall have uniform perforations. The inlet size shall be 15 mm or 20 mm as required.

#### **18.3.13 Sluice Valves-Brass/Gun Metal (Fig. 18.4)**

The sluice valves are used in a pipe line for controlling or stopping flow of water. These shall be of specified size and class and shall be of inside non-raising screw type up to 300 mm size and raising or non-raising screw type above 300 mm with either double flange or double socket ends and cap or hand wheel. These shall in all respects comply with the Indian Standard Specification IS 14846. Class I sluice valves are used for maximum working pressure of 10 Kg/sq.cm (100 metre head) and class II sluice valve for 15 Kg/sq.cm (150 metre head).

The body, domes covers, wedge gate and stuffing box shall be of good quality cast iron, the spindle of bronze, and the nut and valve seats of leaded tin bronze. The bodies, spindles and other parts shall be truly machined with surface smoothly finished. The area of the water way of the fittings shall be not less than the area equal to the nominal bore of the pipe.

The valve shall be marked with an arrow to show the direction of turn for closing of the valve.

#### **18.3.14 Surface Box (Fig. 18.6 & 18.7)**

This shall be of cast iron, well made and free from casting and other defects. All sharp edges shall be removed and finished smooth. The shape and dimensions for surface boxes for stop cocks, sluice valves, fire hydrants, water meters etc. shall be as specified in Fig. 18.3 & 18.4.

The C.I. surface boxes shall be coated with a black bituminous composition except in case of fire hydrants where the cover of the surface box shall be painted with two coats of rust resisting bright luminous yellow paint for clear visibility during night.

#### **18.3.15 Water Meter (Domestic Type) (Fig. 18.4)**

**18.3.15.1** Water meters shall be selected according to flow to be measured and not necessarily to suit a certain size of main. The following points shall govern the selection of meters:

- (a) The maximum flow shall not exceed the nominal capacity of the meter.
- (b) The continuous flow shall be not greater than the continuous running capacity rating.
- (c) The minimum flow to be measured shall be within minimum starting flows.

**18.3.15.2** Inferential water meter has the same accuracy as the semi -positive type at higher flows; it passes unfiltered water better than a semi-positive meter and is lower in cost.

**18.3.15.3** Special care is necessary in selecting the most suitable meter where large rates of flow may exist for short periods. The normal working flow shall be well within the continuous running capacity specified in IS 779, as high rates of flow over short period may cause excessive wear if the meter chosen is too small for the duty.

**18.3.15.4** Owing to the fine clearances in the working parts of meters, they are not suitable for measuring water containing sand or similar foreign matter, and in such cases a filter or dirt box of adequate effective area shall be fitted on the upstream side of the meter. See Fig. 18.4. It shall be noted that the normal strainer fitted inside a meter is not a filter and does not prevent the entry of small particles, such as sand.

**18.3.15.5** Water meters and their parts, especially parts coming in continuous contact with water shall be made of materials resistant to corrosion and shall be non-toxic and non-training. Use of dissimilar metals in contact under water shall be avoided as far as possible in order to minimise electrolytic corrosion.

**18.3.15.6 Body :** The body of water meter shall be made either from Type A or Type B materials as specified below:—

*Type A :* The body of water meters shall be made from bronze, brass or any other corrosion resistant material e.g. Grey iron castings, blackheart malleable iron, pearlitic graphite iron casting.

*Type B:* The body of the water meters shall be made from suitable plastics.

**Note:** Plastics shall have following qualities:

- (i) It shall not affect the potability of water.
- (ii) Elongation, 15 per cent, Min. on a specimen of length 150 mm (for procedure of determination of elongation).
- (iii) Water absorption on immersion for 24 hours should not exceed 0.6 per cent by weight (for procedure of determination of water absorption).
- (iv) It shall be capable of withstanding temperature up to 55°C without undergoing deformation or softening and becoming unsatisfactorily in performance.

**18.3.15.7 Registration Box:** Registration box of water meters of Type A shall be made from bronze, brass, aluminium alloy or suitable plastics. Registration box of water meters of Type B shall be made from suitable plastics or aluminium alloys. The registration box of dry dial water meters shall be provided with one or two escape holes for minimising the accumulation of condensed water.

**18.3.15.8 Cap:** Cap of water meters of Type A shall be made from brass, bronze, aluminium alloy or suitable plastics. The cap of water meters of Type B shall be made of plastics or aluminium alloy. Where the cap and registration box are integral, the materials for cap may be the same as used for registration box. The cap shall be so designed and fixed to the registration box as to avoid entry of water and dirt. The transparent window which covers the dial shall be inserted from the inside into the cap. The protective lid shall be secured by a robust hinge or other suitable method of robust construction.

**18.3.15.9 Locking Arrangement:** Provision shall also be made to lock the lid. The provision shall be such that the lock is conveniently operated from the top. Where the provision is designed for use in conjunction with padlocks, the hole provided for padlocks shall be of a diameter not less than 4 mm.

**18.3.15.10 Wiper:** Where so required for dry-type water meters the transparent window covering the dial shall be provided with a wiper on the inner side for wiping off condensed water.

**18.3.15.11 Connecting Arrangements:** The meter casing shall be fitted in the pipe line by means of two conical or cylindrical nipples or tail pieces with connecting nuts which shall be provided with each meter. The nipples of water meters of Type A shall be made of the same materials as specified for body.

Nipples of water meters of Type B shall be made of the same materials as specified for the body where they are integral with the body of the water meters; where they are separate, they shall be made of malleable iron, galvanized steel or suitable plastics. The nuts shall be of the same material as used for nipples. The internal diameter of the nipple where it connects the pipe line shall be equal to that corresponding to the nominal size of the meter. The threads on the connection shall conform to IS 779. The minimum length of the threads shall be as given in Table 18.5.

**18.3.15.12 Strainers:** Water meters shall be provided with strainers. Strainers shall be of a material which is not susceptible to electrolytic corrosion. They shall be of plastics or other corrosion-resistant materials for both Type A and Type B meters. They shall be rigid, easy to remove and clean, and shall be fitted on the inlet side of the water meter. It shall be possible to remove and clean the strainer in such a way as not to permit disturbing the registration box or tampering with it. The strainer shall have a total area of holes not less than twice the area of the nominal inlet bore of the pipe to which the meter is connected however, in the case of meters provided with internal strainer involving opening of the registration box for cleaning, an additional external strainer shall be fitted on the inlet side satisfying the above requirements.

Overall dimension of water meters shall be as specified in Table 18.6.

**TABLE 18.5**  
**Minimum Length of Thread on Connections**

| <i>Nominal size of meter</i> | <i>Minimum length of thread</i> |
|------------------------------|---------------------------------|
| 15                           | 12                              |
| 20                           | 14                              |
| 25                           | 16                              |
| 40                           | 20                              |
| 50                           | 25                              |

(All dimensions in millimeters)

Screws & studs shall be of brass or other corrosion resistant material.

**TABLE 18.6**  
**Overall Dimensions of Water Meters**

| Nominal size of Meter | Overall length including nipples | Overall width. (Max.) | Overall height (Max.) |
|-----------------------|----------------------------------|-----------------------|-----------------------|
| <i>1</i>              | <i>2</i>                         | <i>3</i>              | <i>4</i>              |
| 15                    | 250                              | 100                   | 180                   |
| 20                    | 290                              | 130                   | 240                   |
| 25                    | 380                              | 170                   | 260                   |
| 40                    | 430                              | 210                   | 300                   |
| 50                    | 470                              | 270                   | 300                   |

All dimensions are in mm.

Tolerance on the overall length shall be  $\pm 5$  mm. for meter with nipples and  $+0,-2$  mm for meters without nipples.



**18.3.15.13 Capacity on Short Period Rating or Nominal Capacity:** The nominal capacity of the water meters shall be as specified in Table 18.7. The meters shall be capable of giving minimum discharges as stated in the table without the head loss exceeding 10 m within the meters.

**18.3.16 Yarn (Spun)**

Spun yarn shall be of clean hemp and of good quality. It shall be soaked in hot coal tar or bitumen and cooled before use.

**18.4 LAYING AND JOINTING OF PIPES AND FITTINGS**

**18.4.1 Unloading**

**18.4.1.1** The pipes shall be unloaded where they are required.

**18.4.1.2 Unloading (except where mechanical handling facilities are available) :** Pipes weighing up to 60 kg shall be handled by two persons by hand passing. Heavier pipes shall be unloaded from the lorry or wagon by holding them in loops, formed with ropes and sliding over planks set not steeper than 45 degree. The planks shall be sufficiently rigid and two ropes shall always be used to roll the pipes down the planks. The ropes should be tied on the side opposite the unloading. Only one pipe shall be unloaded at a time.

**TABLE 18.7  
Nominal Capacity of Water Meters**

| Discharge per hour         |                             |                           |
|----------------------------|-----------------------------|---------------------------|
| Nominal size of meter (mm) | Semi positive Type (liters) | Inferential Type (liters) |
| 15                         | 2000                        | 2500                      |
| 20                         | 3400                        | 3500                      |
| 25                         | 5500                        | 5500                      |
| 40                         | 10000                       | 16000                     |
| 50                         | 15000                       | 23000                     |

**18.4.1.3** Under no circumstances shall the pipes be thrown down from the carriers or be dragged or rolled along hard surfaces.

**18.4.1.4** The pipes shall be checked for any visible damage (such as broken edges, cracking or spalling of pipe) while unloading and shall be sorted out for reclamation. Any pipe which shows sufficient damage to preclude it from being used shall be discarded.

**18.4.2 Storing**

**18.4.2.1** The pipes and specials shall be handled with sufficient care to avoid damage to them. These shall be lined up on one side of the alignment of the trench, socket facing upgrade when line runs uphill and upstream when line runs on level ground.

**18.4.2.2** Each stack shall contain pipes of same class and size, consignment or batch number and particulars of suppliers, wherever possible, shall be marked on the stack.

**18.4.2.3** Storage shall be done on firm, level and clean ground. Wedges shall be provided at the bottom layer to keep the stack stable.

**18.4.3 Cutting**

**18.4.3.1** Cutting of pipes may be necessary when pipes are to be laid in lengths shorter than the lengths supplied, such as while replacing accessories like tees, bends, etc. at fixed position in the pipe lines.



**18.4.3.2** A line shall be marked around the pipe with a chalk piece at the point where it is to be cut. The line shall be so marked that the cut is truly at right angle to the longitudinal axis of the pipe. The pipe shall be rigidly held on two parallel rafters nailed to cross beams, taking care that the portion to be cut does not overhang and the cut mark is between the two rafters. The pipe shall be neatly cut at the chalk mark with carpenter's saw or hacksaw having a long blade, by slowly rotating the pipe around its longitudinal axis so as to have the uncut portion on top for cutting. Cutting of the pipe at the overhang should, as far as possible, be avoided, as an overhanging and is liable to tear off due to its weight before the cutting is complete.

#### **18.4.4 Trenches**

**18.4.4.1** The trenches shall be so dug that the pipes may be laid to the required alignment and at required depth.

**18.4.4.2** Cover shall be measured from top of pipe to the surface of the ground.

**18.4.4.3** The bed of the trench, if in soft or made up earth, shall be well watered and rammed before laying the pipes and the depressions, if any, shall be properly filled with earth and consolidated in 20 cm layers.

**18.4.4.4** If the trench bottom is extremely hard or rocky or loose stony soil, the trench shall be excavated at least 150 mm below the trench grade. Rocks, stone or other hard substances from the bottom of the trench shall be removed and the trench brought back to the required grade by filling with selected fine earth or sand (or fine moorum if fine soil or sand is not available locally) and compacted so as to provide a smooth bedding for the pipe. Where excavation requires blasting operation, it shall be ensured that no pipes have been stacked in the vicinity and completed pipe line in the vicinity has already been covered before starting of blasting operations; this is necessary to prevent damage to the exposed pipes in the vicinity by falling stones as a result of blasting.

**18.4.4.5** After the excavation of the trench is completed, hollows shall be cut at the required position to receive the socket of the pipes and these hollows shall be of sufficient depth to ensure that the barrels of the pipes shall rest throughout their entire length on the solid ground and that sufficient spaces left for jointing the underside of the pipe joint. These socket holes shall be refilled with sand after jointing the pipe.

**18.4.4.6** Roots of trees within a distance of about 0.5 metre from the side of the pipe line shall be removed or killed.

**18.4.4.7** The excavated materials shall not be placed within 1 metre or half of the depth of the trench, whichever is greater, from the edge of the trench. The materials excavated shall be separated and stacked so that in refilling they may be re-laid and compacted in the same order to the satisfaction of the Engineer-in-Charge.

**18.4.4.8** The trench shall be kept free from water. Shoring and timbering shall be provided wherever required. Excavation below water table shall be done after dewatering the trenches.

**18.4.4.9** Where the pipe line or drain crosses an existing road, the road crossing shall be excavated half at a time, the 2nd half being commenced after the pipes have been laid in the first half and the trench refilled. Necessary safety measures for traffic as directed shall be adopted. All types, water mains cables, etc. met within the course of excavation shall be carefully protected and supported. Care shall be taken not to disturb the electrical and communication cable met with during course of excavation, removal of which, if necessary, shall be arranged by the Engineer-in-Charge.

### **18.4.5 Laying**

**18.4.5.1** The pipes shall be lowered into the trench by means of suitable pulley blocks, sheer legs chains ropes etc. In no case the pipes shall be rolled and dropped into the trench. One end of each rope may be tied to a wooden or steel peg driven into the ground and the other end held by men which when slowly released will lower the pipe into the trench. After lowering, the pipes shall be arranged so that the spigot of one pipe is carefully centered into the socket of the next pipe, and pushed to the full distance that it can go. The pipe line shall be laid to the levels required. Specials shall also be laid in their proper position as stated above.

**18.4.5.2** Where so directed, the pipes and specials may be laid on masonry or concrete pillars. The pipe laid on the level ground, shall be laid with socket facing the direction of flow of water.

**18.4.5.3** The pipes shall rest continuously on the bottom of the trench. The pipes shall not rest on lumps of earth or on the joints. Four metre long wooden templates may be used to check the level of the bed. Clearance of approximately 100 mm in depth and width equal to length of the collar plus 30mm on both sides shall be provided at the joint which shall be refilled from sides after the joint is made.

**18.4.5.4** In unstable soils, such as soft soils and dry lumpy soils it shall be checked whether the soils can support the pipe lines and if required suitable special foundation shall be provided.

**18.4.5.5** Some clayey soils (for example black cotton soil) are drastically affected by extremes of saturation and dryness. In changing from saturated to a dry condition, these soils are subjected to extraordinary shrinkage which is usually seen in the form of wide and deep cracks in the earth surface and may result in damages to under ground structures, including pipe materials. The clay forms a tight gripping bond with the pipe, subjecting it to excessive stresses as the clay shrinks. It is recommended that in such cases an envelope of a minimum 100 mm of tamped sand shall be made around the pipe line to avoid any bonding.

**18.4.5.6** In places where rock is encountered, cushion of fine earth or sand shall be provided for a depth of 150 mm by excavating extra depth of the trench, if necessary, and the pipes laid over the cushion. Where the gradient of the bed slopes is more than 30 degree it may be necessary to anchor a few pipes against sliding downwards (Fig. 18.8).

### **18.4.6 Thrust Blocks (Fig. 18.8)**

**18.4.6.0** Thrust blocks are required to transfer the resulting hydraulic thrust from the fitting of pipe on to a larger load bearing soil section.

**18.4.6.1** Thrust blocks shall be installed wherever there is a change in the direction/size of the pipe line or the pressure line diagram, or when the pipe line ends at a dead end. If necessary, thrust blocks may be constructed at valves also.

**18.4.6.2** Thrust blocks shall be constructed taking into account the pipe size, water pressure, type of fitting, gravity component when laid on slopes and the type of soil. The location of thrust blocks for various types' fittings is given in Fig. 18.8.

**18.4.6.3** When a fitting is used to make a vertical bend, it shall be anchored to a concrete thrust block designed to have enough weight to resist the upward and outward thrust. Similarly at joints, deflected in vertical plane, it shall be ensured that the weight of the pipe, the water in the pipe and the weight of the soil over the pipe provide resistance to upward movement. If it is not enough, ballast or concrete shall be placed around the pipe in sufficient weight to counteract the thrust.

**18.4.6.4** When the line is under pressure there is an outward thrust at each coupling. Good soil, properly tamped is usually sufficient to hold pipe from side movement. However, if soft soil conditions are encountered, it may be necessary to provide side thrust blocks or other means of anchoring. In such cases only pipe on each side of the deflected coupling shall be anchored without restricting the coupling.

**18.4.6.5** Pipes on slopes need be anchored only when there is a possibility of the back fill around the pipe sloping down the hill and carrying the pipe with it. Generally for slopes up to 30 degree good well drained soil carefully tamped in layers of 100 mm under and over the pipe, right up to the top of trench will not require anchoring.

**18.4.6.6** For steeper slopes, one out of every three pipes shall be held by straps fastened to vertical supports anchored in concrete.

#### **18.4.7 Back Filling and Tamping**

**18.4.7.1** Back filling shall follow pipe installation as closely as possible to protect pipe from falling boulders, eliminating possibility of lifting of the pipe due to flooding of open trench and shifting pipe out of line by caved in soil.

**18.4.7.2** The soil under the pipe and coupling shall be solidly tamped to provide firm and continuous support for the pipe line. Tamping shall be done either by tamping bars or by using water to consolidate the back fill materials.

**18.4.7.3** The initial back fill material used shall be free of large stones and dry lumps. In stony areas the material for initial back fill can be shaved from the sides of the trenches. In bogs and marshes, the excavated material is usually little more than vegetable matter and this should not be used for bedding purposes. In such cases, gravel or crushed stone shall be hauled in.

**18.4.7.4** The initial back fill shall be placed evenly in a layer of about 100 mm thick. This shall be properly consolidated and this shall be continued till there is a cushion of at least 300 mm of cover over the pipe.

**18.4.7.5** If it is desired to observe the joint or coupling during the testing of mains they shall be left exposed. Sufficient back fill shall be placed on the pipe to resist the movement due to pressure while testing.

**18.4.7.6** Balance of the back fill need not be so carefully selected as the initial material. However, care shall be taken to avoid back filling with large stones which might damage the pipe when spaded into the trench.

**18.4.7.7** Pipes in trenches on a slope shall have extra attention to make certain that the newly placed back fill will not become a blind drain in effect because until back fill becomes completely consolidated there is a tendency for ground or surface water to move along this looser soil resulting in a loss of support to the pipe. In such cases, the back fill shall be tamped with extra care and the tamping continued in 100 mm layers right up to the ground level.

#### **18.4.8 Hydrostatic Tests (Fig. 18.9)**

**18.4.8.1** After a new pipe has been laid, jointed and back filled (or any valved section thereof), it shall be subjected to the following two tests:

- (a) Pressure test at a pressure of at least double the maximum working pressure-pipe and joints shall be absolutely water tight under the test.
- (b) Leakage test (to be conducted after the satisfactory completion of the pressure test) at a pressure to be specified by the authority for duration of two hours.

**18.4.8.2 Hydrostatic Tests:** The portions of the line shall be tested by subjecting to pressure test as the laying progresses before the entire line is completed. In this way any error of workmanship will be found immediately and can be corrected at a minimum cost. Usually the length of the section to be tested shall not exceed 500 m.

**18.4.8.3** Where any section of a main is provided with concrete thrust blocks or anchorages, the pressure test shall not be made until at least five days have elapsed after the concrete is cast. If rapid hardening cement has been used in these blocks or anchorages, test shall not be made until at least two days have elapsed.

**18.4.8.4** Prior to testing, enough back fill as described in 18.4.7 shall be placed over the pipe line to resist upward thrust. All thrust blocks forming part of the finished line shall have been sufficiently cured and no temporary bracing shall be used.

**18.4.8.5** The open end of the section shall be sealed temporarily with an end cap having an outlet which can serve as an air relief vent or for filling the line, as may be required. The blind face of the end cap shall be properly braced during testing by screw jacks and wooden planks or steel plate as shown in Fig. 18.6.

**18.4.8.6** The section of the line to be tested shall be filled with water manually or by a low pressure pump. Air shall be vented from all high spots in the pipe line before making the pressure strength test because entrapped air gets compressed and causes difficulty in raising the required pressure for the pressure strength test.

**18.4.8.7** The test pressure shall be gradually raised at the rate of approximately one Kg./sq. cm./min. The duration of the test period if not specified shall be sufficient to make a careful check on the pipe line section.

**18.5 LAYING AND JOINTING OF CAST IRON PIPES AND FITTINGS (EXTERNAL WORK)**

**18.5.0** Specifications described in 18.4 shall apply, as far as applicable.

**TABLE 18.8**  
**Test Pressure for Pipes**

| <i>Class of pipe</i> | <i>Maximum field test pressure kgf./sq.cm</i> |
|----------------------|---|
| 5                    | 3.75  |
| 10                   | 7.50  |
| 15                   | 11.25   |
| 20                   | 15.00   |
| 25                   | 18.75   |

**18.5.1 Trenches**

**18.5.1.1** The gradient is to be set out by means of boning rods and the required depth to be excavated at any point of the trench shall be regarded as directed by the Engineer -in-Charge. The depth of the trench shall not be less than 1 metre measured from the top of the pipe to the surface of the ground under roads and not less than 0.75 metre elsewhere.

**18.5.1.2** The width of the trench shall be the nominal diameter of the pipe plus 40 cm but it shall not be less than 55 cm in case of all kinds of soils excluding rock and not less than 1 metre in case of rock.

### 18.5.2 Laying

Any deviation either in plan or elevation less than 11.25 degrees shall be effected by laying the straight pipes around a flat curve of such radius that minimum thickness of lead at the face of the socket shall not be reduced below 6 mm or the opening between spigot and socket increased beyond 12 mm at any joint. A deviation of about 2.25 degree can be effected at each joint in this way. At the end of each day's work the last pipe laid shall have its open ends securely closed with a wooden plug to prevent entry of water, soil, rats and any other foreign matter into the pipe.

### 18.5.3 Lead Caulked Joints with Pig Lead

**18.5.3.1** This type of lead caulking is generally done in providing joints in gas water and sewer lines wherever it is practicable to use cast lead caulking, but not in case of wet conditions.

**18.5.3.2** The approximate depth and weights of pig lead for various diameters of C.I. pipes and specials shall be as given in Table 18.9.

**TABLE 18.9**  
**Lead for Different Sizes of Pipes**

| Nominal size of pipe (mm) | Lead per joint (Kg.) | Depth of lead joint (mm) |
|---------------------------|----------------------|--------------------------|
| (1)                       | (2)                  | (3)                      |
| 80                        | 1.8                  | 45                       |
| 100                       | 2.2                  | 45                       |
| 125                       | 2.6                  | 45                       |
| 150                       | 3.4                  | 50                       |
| 200                       | 5.0                  | 50                       |
| 250                       | 6.1                  | 50                       |
| 300                       | 7.2                  | 55                       |
| 350                       | 8.4                  | 55                       |
| 400                       | 9.5                  | 55                       |
| 450                       | 14.0                 | 55                       |
| 500                       | 15.0                 | 60                       |
| 600                       | 19.0                 | 60                       |
| 700                       | 22.0                 | 60                       |
| 750                       | 25.0                 | 60                       |

**Note:** 1. The quantity of lead given in the table is on average basis and a variation of 10 per cent is permissible.

2. Before pipes are jointed on large scale, three or four sample joints shall be made and the average consumption of lead per joint shall be got approved by the Engineer-in-Charge.

Only required quantity of spun yarn shall be put so as to give the specified depth of lead in the joint.

### 18.5.4 Lead Caulked Joint with Lead Wool Yarn

**18.5.4.1** This type of lead caulking is generally done when it is inconvenient or dangerous to use molten lead for joints, for example in cases such as inverted joints or in wet trenches or in exceptional cases. In such cases the joints shall be made with lead wool or yarn. Caulking with lead wool or yarn shall however be not carried out without the prior permission of Engineer-in-Charge.

**18.5.4.2** The approximate weights and depths of lead wool or lead yarn required for each joint of various dia. of C.I. pipes and specials shall be as given in Table 18.10. Just sufficient quantity of spun yarn shall be put so as to give specified depth of lead wool.

**18.5.4.3 Jointing:** The spun yarn shall first be inserted and caulked into the socket as described under jointing with pig lead. Lead wool or yarn shall then be introduced in the joint in strings not less than 6 mm thick and the caulking shall be repeated with each turn of lead wool or yarn. The whole of the lead wool or yarn shall be compressed into a dense mass. The joint shall then be finally finished flush with face of the socket.

**18.5.5 Flanged joints**

**18.5.5.1** Cast iron pipes may be jointed by means of flanges cast on. The jointing material used between flanges of pipes shall be compressed fiber board or rubber of thickness between 1.5 mm to 3 mm. The fiber board shall be impregnated with chemically neutral mineral oil and shall have a smooth and hard surface. Its weight per m<sup>2</sup> shall be not less than 112 gm/mm thickness.

**TABLE 18.10**

| Diameter of pipe (mm) | Weight of lead wool or lead yarn (kg) | Depth of lead wool or lead yarn (mm) |
|-----------------------|---------------------------------------|--------------------------------------|
| 80                    | 0.80                                  | 19                                   |
| 100                   | 0.90                                  | 19                                   |
| 125                   | 1.25                                  | 20                                   |
| 150                   | 1.60                                  | 23                                   |
| 200                   | 2.05                                  | 23                                   |
| 250                   | 2.95                                  | 25                                   |
| 300                   | 3.50                                  | 25                                   |
| 350                   | 4.65                                  | 29                                   |
| 400                   | 5.70                                  | 31                                   |
| 450                   | 6.70                                  | 32                                   |
| 500                   | 8.30                                  | 33                                   |
| 600                   | 10.00                                 | 35                                   |
| 700                   | 11.80                                 | 36                                   |
| 750                   | 13.60                                 | 38                                   |
| 800                   | 15.40                                 | 40                                   |
| 900                   | 16.80                                 | 40                                   |

**Note:** An allowance of five per cent variation in the specified weights and depths is permissible.

**18.5.5.2** Each bolt should be tightened a little at a time taking care to tighten diametrically opposite bolts alternatively. The practice of fully tightening the bolts one after another shall not be allowed.

**18.5.5.3** Several proprietary flexible joints are available for jointing cast iron pipes and these may be used with the specific approval of the authority, however, they shall be used strictly in accordance with the manufacturer’s instructions.

**18.5.5.4** For joints in small diameter cast iron piping, copper-alloy screwed unions or ferrules shall be used, and for large dia. The joints shall be made by flanged connecting pieces.

**18.5.6 Hydrostatic**

The procedure for testing for leakage under pressure shall be as described in Appendix D of Chapter 18 which is to be read in addition to 18.4.8. The joints of pipes and specials have to be repaired till the leakage in the portion under test is within the specified limit indicated in Appendix-D.

**18.5.7 Measurements**

**18.5.7.1** The net length of pipes as laid or fixed, shall be measured in the running metres correct to a cm. specials shall be excluded and enumerated and paid for separately. The portion of the pipe within the collar at the joints shall not be included in the length of pipe work.

**18.5.7.2** Excavation, refilling, shoring and timbering in trenches masonry or concrete pillars and thrust blocks, wherever required, shall be measured and paid for separately, under relevant items of work.

**18.5.7.3** Lead caulked joints shall be measured and paid for separately.

#### **18.5.8 Rate**

The rate shall include the cost of materials and labour involved in all the operations described above except for the items measured/enumerated separately under Para 18.4.7.1, 18.4.7.2, 18.4.7.3 which shall be paid for separately.

### **18.6 LAYING AND JOINTING OF G.I. PIPES (EXTERNAL WORK)**

**18.6.0** The specifications described in 18.4 shall apply, as far as applicable.

#### **18.6.1 Trenches**

The galvanised iron pipes and fittings shall be laid in trenches. The widths and depths of the trenches for different diameters of the pipes shall be as in Table 18.11.

**TABLE 18.11**

| Dia of pipe (mm) | Width of trench (cm) | Depth of trench (cm) |
|------------------|----------------------|----------------------|
| 15 to 50         | 30                   | 60                   |
| 65 to 100        | 45                   | 75                   |

At joints the trench width shall be widened where necessary. The work of excavation and refilling shall be done true to line and gradient in accordance with general specifications for earth work in trenches.

When excavation is done in rock, it shall be cut deep enough to permit the pipes to be laid on a cushion of sand minimum 7.5 cm deep.

#### **18.6.2 Cutting and Threading**

Where the pipes have to be cut or rethreaded, the ends shall be carefully filed out so that no obstruction to bore is offered. The end of the pipes shall then be carefully threaded conforming to the requirements of IS 554 with pipe dies and tapes in such a manner as will not result in slackness of joints when the two pieces are screwed together. The taps and dies shall be used only for straightening screw threads which have become bent or damaged and shall not be used for turning of the threads so as to make them slack, as the later procedure may not result in a water tight joint. The screw threads of pipes and fitting shall be protected from damage until they are fitted.

#### **18.6.3 Jointing**

The pipes shall be cleaned and cleared of all foreign matter before being laid. In jointing the pipes, the inside of the socket and the screwed end of the pipes shall be oiled and rubbed over. **Teflon Tape** should be used on threads instead of '**Dhaaga/ Safeda**'. The end shall then be screwed in the socket, Tee etc. with the pipe wrench. Care shall be taken that all pipes and fittings are properly jointed so as to make the joints completely water tight and pipes are kept at all times free from dust and dirt during fixing. Burr from the joint shall be removed after screwing. After laying, the open ends of the pipes shall be temporarily plugged to prevent access of water, soil or any other foreign matter.

#### **18.6.4 Thrust Blocks (Fig. 18.8)**

In case of bigger diameter pipes where the pressure is very high, thrust blocks of cement concrete 1:2:4 (1 cement: 2 coarse sand: 4 graded stone aggregate of 20 mm nominal size) of adequate size and shape shall be provided on all bends to transmit the hydraulic thrust to the ground, spreading it over a sufficient areas, depending upon the type of soil met with.



### **18.6.5 Painting**

The pipes shall be painted with two coats of anticorrosive bitumastic paint of approved quality.

### **18.6.6 Testing of Joints**

The pipes and fittings after they are laid and jointed shall be tested to hydraulic pressure of 6 Kg/sq. cm (60 meter). The pipes shall be slowly and carefully charged with water allowing all air to escape and avoiding all shock or water hammer. The draw off taps and stop cocks shall then be closed and specified hydraulic pressure shall be applied gradually. Pressure gauge must be accurate and preferably should have been recalibrated before the test. The test pump having been stopped, the test pressure should be maintained without loss for at least half an hour. The pipes and fittings shall be tested in sections as the work of laying proceeds, having the joints exposed for inspection during the testing. Pipes or fittings which are found leaking shall be replaced and joints found leaking shall be redone, without extra payment.

### **18.6.7 Trench Filling**

The pipes shall be laid on a layer of 7.5 cm sand and filled up to 15 cm above the pipes. The remaining portion of the trench shall then be filled with excavated earth as described in 20.3.7. The surplus earth shall be disposed off as directed.

### **18.6.8 Measurements**

The lengths shall be measured in running metre correct to a cm for the finished work, which shall include G.I. pipe and G.I. fittings such as bends, tees, elbows reducers, crosses, plugs, sockets, nipples and nuts, but exclude brass or gun metal taps (cocks), valves, unions, lead connection pipes and shower rose. All pipes and fittings shall be classified according to their diameters, method of jointing and fixing substance quality and finish. In case of fittings of an equal bore the pipe shall be described as including all cuttings and wastage. In case of fittings of unequal bore the largest bore shall be measured.

**Note:** G.I. unions shall be paid for separately in external work as well as in internal work.

Digging and refilling of trenches shall either be measured separately as specified in the appropriate clauses of excavation and earth work or clubbed with main item.

### **18.6.9 Rate**

The rate shall include the cost of labour and materials involved in all the operations described above. The rate shall not include excavation in trenches, painting of pipes and sand filling all round the pipes, unless otherwise specified.

## **18.7 LAYING AND JOINTING G.I. PIPES (INTERNAL WORK)**

**18.7.0** For internal work the galvanised iron pipes and fittings shall run on the surface of the walls or ceiling (not in chase) unless otherwise specified. The fixing shall be done by means of standard pattern holder bat clamps, keeping the pipes about 1.5 cm clear of the wall. When it is found necessary to conceal the pipes, chasing may be adopted or pipes fixed in the ducts or recess etc., provided there is sufficient space to work on the pipes with the usual tools. The pipes shall not ordinarily be buried in walls or solid floors. Where unavoidable, pipes may be buried for short distances provided adequate protection is given against damage and where so required joints are not buried. Where directed by the Engineer-in-Charge, a M.S. tube sleeve shall be fixed at a place the pipe is passing through a wall or floor for reception of the pipe and to allow freedom for expansion and contraction and other movements. In case the pipe is embedded in walls or floors it should be painted with anticorrosive bitumastic paints of approved quality. The pipe shall not come in contact with lime mortar or lime concrete as the pipe is affected by time. Under the floors the pipes shall be laid in layer of sand filling as done under concrete floors.



All pipes and fittings shall be fixed truly vertical and horizontal unless unavoidable. The pipes shall be fixed to walls with standard pattern holder bat clamps of required shape and size so as to fit tightly on the pipes when tightened with screwed bolts, these clamps shall be embedded in brick work in cement mortar 1:3 (1 cement: 3 coarse sand), and shall be spaced at regular intervals in straight lengths as shown in Table 18.12.

The clamps shall be fixed at shorter lengths near the fittings as directed by the Engineer-in-Charge.

For G.I. pipes 15 mm diameter, the holes in the walls and floors shall be made by drilling with chisel or jumper and not by dismantling the brick work or concrete. However, for bigger dimension pipes the holes shall be carefully made of the smallest size as directed by the Engineer-in-Charge. After fixing the pipes the holes shall be made good with cement mortar 1:3 (1 cement: 3 coarse sand) and properly finished to match the adjacent surface.

**TABLE 18.12**

| Dia. of Pipe (mm) | Horizontal length (m) | Vertical length (m) |
|-------------------|-----------------------|---------------------|
| 15                | 2                     | 2.5                 |
| 20                | 2.5                   | 3                   |
| 25                | 2.5                   | 3                   |
| 32                | 2.5                   | 3                   |
| 40                | 3                     | 3.5                 |
| 50                | 3                     | 3.5                 |
| 65                | 3.5                   | 5                   |
| 80                | 3.5                   | 5                   |

Unions will be provided to facilitate connections additions and alterations as well as for maintenance and for change of pipes. The locations where unions are to be provided will be decided with prior written approval of the Engineer-in-Charge.

#### **18.7.1 Measurements**

The lengths shall be measured in running metre correct to a cm for the finished work, which shall include G.I. pipe and G.I. fittings such as bends, tees elbows, reducers, crosses, plugs, sockets, nipples and nuts, but exclude brass or gun metal taps (cocks), valves, unions, lead connection pipes and shower rose. All pipes and fittings shall be classified according to their diameters, method of jointing and fixing substance, quality and finish. In case of fittings of an equal bore the pipe shall be described as including all cuttings and waste. In case of fittings of unequal bore, the largest bore shall be measured. Pipes laid in trenches (or without supports) and pipes fixed to walls, ceilings, etc. with supports shall be measured separately.

#### **18.7.2 Rate**

The rate shall include the cost of labour and material involved in all the operations described above. The rate shall include the cost of cutting holes in walls and floors and making good the same. This shall not however, include concealed pipe work in which case cutting of chase and making good shall be paid separately. It shall not include painting of pipes and providing sleeves, unless specified otherwise. It will also not include union which shall be paid for separately.

### **18.8 POLYPROPYLENE RANDOM CO-POLYMER (PP-R) PIPES**

**18.8.1** The PP-R is a bonded, multilayer pipe consisting of different layers of the pipe:-

- (a) The inner-most layer of the pipe to be Anti – bacterial to prevent bacteria growth inside pipe surface.
- (b) The middle layer to be of plain PP-R which is neither in contact with Water and nor under direct effect of the atmospheric conditions.
- (c) The outer-most layer to be of U.V. stabilized PP-R to prevent the pipe surface from sunlight under exposed atmospheric conditions.

The pipes should in general be conforming to the requirements of IS 15801 except that specified with in nomenclature of the item. The pipes should have smooth inner surface with non-contracting diameters. The pipes shall be cleanly finished, free from cracks and other defects. The pipes shall be clean and well cut along ends after taking into consideration the desired length, using the pipe scissors. The Polypropylene used for manufacturing the pipe shall conform to the requirements of IS 10951 and IS 10910. The specified base density shall be between 900 kg/m<sup>3</sup> and 910 kg/m<sup>3</sup> when determined at 27°C. The resin should be mixed with sufficient quantity of colour master batches. The colour master batch should be uniform throughout the pipe surface. The standard dimension ratio (SDR) i.e. ratio of the nominal outer diameter of a pipe to its nominal wall thickness should be 7.4/11 as given in the item.

### 18.8.2 Fittings

Plain fittings, Chrome plated brass threaded fittings and Valves shall be as per nomenclature of item or as directed by engineer- in- charge.

- (a) The plain fittings shall be Polypropylene Random Copolymer and comply with all the requirements of the pipes. The plain fittings shall comprise of Socket, Elbow, Tee, Cross, Reducer socket, Reduction Tee, End Cap, Crossover, Omega, Threaded Plug and wall clamps in available sizes.
- (b) The Chrome Plated Brass threaded fittings shall be Chrome Plated Brass threaded piece molded inside Polypropylene random copolymer fitting. The maternal shall comply with all the requirements of the pipes. The Chrome plated Brass threaded fittings shall comprise of Socket, Elbow and Tee (Male & Female) in available sizes. These are the fittings for C.P. connections and for continuations from existing Galvanized Iron Pipes and fittings.
- (c) The valves shall be Polypropylene Random Copolymer Valves. The valves comprise of Gate Valve, Ball Valve, Concealed stop valve and Chrome Coated Valve in available sizes.

The Valves sizes availability in Polypropylene Random Copolymer is as follows:-

- |                            |   |   |
|----------------------------|---|---|
| (i) Gate Valve             | - | 20 mm to 63 mm                            |
| (ii) Ball Valve            | - | 20 mm, 25 mm, 32 mm, 40 mm, 50 mm & 63 mm |
| (iii) Concealed Stop valve | - | 20 mm & 25 mm                             |
| (iv) Chrome Coated Valve   | - | 20 mm & 25 mm                             |

However, the other Brass/Bronze Valves can be connected to Polypropylene Random pipes using C.P. Brass threaded fittings of desired sizes.

### 18.8.3 Laying and Jointing of Pipes and Fittings

The specifications described in 18.4 shall apply as far as possible. The pipes and fittings shall run in wall chase as specified. Pipes shall run only in vertical or horizontal alignment as far as possible. The installation of pipes is similar to that of the metal pipes with the only difference in the jointing procedure. The jointing of the PP-R pipes and fittings are done by fusion welding by means of a welding machine. The marking on pipe shall carry the following information:-

- (c) Manufacturer's name/ trade mark
- (d) PPR pipe
- (e) SDR-
- (f) Out side diameter and minimum wall thickness
- (g) Lot No. / Batch No. containing date of manufacturing. And machine number.

**18.8.4** The out side diameter of pipes, tolerance in the same and ovality of pipe shall be as given in Table 18.13 below.

**TABLE 18.13**  
**Outside Diameter, Tolerance and Ovality of Pipes**

| Sl. No. | Nominal Size<br>DN | Outside Diameter<br>(mm) | Tolerance (Only positive tolerance)<br>(mm) | Ovality<br>(mm) |
|---------|--------------------|--------------------------|---|-----------------|
| (i)     | 16                 | 16.0                     | 0.3   | 1.2             |
| (ii)    | 20                 | 20.0                     | 0.3   | 1.2             |
| (iii)   | 25                 | 25.0                     | 0.3   | 1.2             |
| (iv)    | 32                 | 32.0                     | 0.3   | 1.3             |
| (v)     | 40                 | 40.0                     | 0.4   | 1.4             |
| (vi)    | 50                 | 50.0                     | 0.5   | 1.4             |
| (vii)   | 63                 | 63.0                     | 0.6   | 1.6             |
| (viii)  | 75                 | 75.0                     | 0.7   | 1.6             |
| (ix)    | 90                 | 90.0                     | 0.9   | 1.8             |
| (x)     | 110                | 110.0                    | 0.9   | 2.2             |

1. The values specified for tolerance on outside diameter have been calculated as  $0.009DN$ , rounded off to the next higher 0.1 mm subject to minimum of 0.3 mm. No negative tolerances are allowed.

2. The basis for the values specified for ovality is:

- (a) For nominal outside diameters  $\leq 75\text{mm}$ , the tolerance equals  $(0.008 DN+1.0)$  mm, rounded to the next higher 0.1 mm, with a minimum value of 1.2 mm.
- (b) For nominal outside diameters  $\geq 75\text{mm}$  and  $\leq 250\text{mm}$ , the tolerance equals  $0.20 DN$ , rounded to the next higher 0.1 mm.
- (c) For nominal outside diameter  $> 250$  mm, the tolerance equals  $0.35 DN$ , rounded to the next higher 0.1 mm.

### 18.8.5 Wall Thickness

The minimum and maximum wall thickness of pipes shall be as given in Table 18.14 below:-

**TABLE 18.14**

| Sl. No. | Nominal Size<br>DN | SDR 11 |       | SDR 7.4 |       |
|---------|--------------------|--------|-------|---------|-------|
|         |                    | Min    | Max   | Min     | Max   |
| (1)     | (2)                | (3)    | (4)   | (5)     | (6)   |
| (i)     | 16                 | -      | -     | 2.20    | 2.70  |
| (ii)    | 20                 | 1.90   | 2.30  | 2.80    | 3.30  |
| (iii)   | 25                 | 2.30   | 2.80  | 3.50    | 4.10  |
| (iv)    | 32                 | 2.90   | 3.40  | 4.40    | 5.10  |
| (v)     | 40                 | 3.70   | 4.30  | 5.50    | 6.30  |
| (vi)    | 50                 | 4.60   | 5.30  | 6.90    | 7.80  |
| (vii)   | 63                 | 5.80   | 6.60  | 8.60    | 9.70  |
| (viii)  | 75                 | 6.80   | 7.70  | 10.30   | 11.60 |
| (ix)    | 90                 | 8.20   | 9.30  | 12.30   | 13.80 |
| (x)     | 110                | 10.00  | 11.20 | 15.10   | 16.90 |

**Note:** The wall thickness tolerances have been calculated on the following basis:

- (a) Limit deviation =  $0.1e + 0.2$  mm rounded up to the nearest 0.1 mm.
- (b) A local increase in wall thickness of up to  $+0.2e$  is permissible for  $e$  up to 10 mm and up to  $0.15e$  for  $e$  greater than 10 mm. The mean of the measurement shall, however, still lie within the given limit deviations.

The quality of each installation system ultimately depends on the tightness, stability and lifetime of its connections. The pipe of the desired length is cut using the pipe scissors. The proper heating piece is taken and mounted on the welding machine. The welding device is switched on - Control lamp and switch lamp will lit. When ready, control lamp gets off, which means that welding temperature of 260 Degrees  $\pm$ 10 Degrees Celsius has been reached. The pipe end and the fitting to be welded are heated on the welding machine. Before heating the fitting and the pipe, the dirty welding tools, pipe and fitting are cleaned with a cloth. When heated up (with heating time as per the Table shown below), the pipe and the fitting is removed from the welding machine and the two pieces connected together by applying a little pressure without twisting. The joint is allowed to cool down for a few seconds. The welding process is that safe because the properly heated part of Polypropylene create a homogeneous connection.

**Guidelines for Welding PP-R Pipes and Fittings (DVS Guideline 2207, Part II)**

| <i>Outer diameter of pipe(mm)</i> | <i>Heating Time (Seconds)</i> | <i>Cooling Period (Minutes)</i> |
|-----------------------------------|-------------------------------|---------------------------------|
| 16                                | 5                             | 2                               |
| 20                                | 5                             | 2                               |
| 25                                | 7                             | 2                               |
| 32                                | 8                             | 4                               |
| 40                                | 12                            | 4                               |
| 50                                | 18                            | 4                               |
| 63                                | 24                            | 6                               |
| 75                                | 30                            | 8                               |
| 90                                | 30                            | 8                               |

The same procedure shall be adapted for exposed as well as concealed fittings. The Crossovers may be used wherever the overlapping of the PP-R pipes is required. The fixing shall be done by means of Wall Support Clamps keeping the pipes about 1.5 cm clear of the wall where to be laid on the surface. Where it is specified to conceal the pipes, chasing may be adopted. For pipes fixed in the shafts, ducts etc. there should be sufficient space to work on the pipes with the usual tools. Pipe sleeves shall be fixed at a place the pipe is passing, through a wall or floor for reception of the pipe and allow freedom for expansion and contraction and other movements. Fixed supports prevent any movement of the pipe by fixing it at some points. Fittings are used in creating the fixed points. Fixed supports must not be installed at bending parts and the direction changes must be done in the pipe itself. In between the fixed supports some arrangements must be done to compensate any potential elongation or shrinkage in the pipe length. For exposed straight pipes having length more than 5 meters, to compensate the expansion an expansion piece must be used.

**18.8.6 Piping Installation Support**

Piping shall be properly supported by means of wall support clamps as specified and as required, keeping in view the proper designing for expansion and contraction. Risers shall be supported at each floor with clamps. Due to high coefficient of thermal expansion the heat losses through the pipes is highly reduced. Therefore, for internal Bathroom hot geyser water distribution lines, the insulation is often not required.

**18.8.7 Installation of Water Meter and Valves**

PP-R lines shall be cut to the required lengths at the position where the meter and Valves are required to be fixed. Suitable C.P. Brass threaded fittings shall be attached to the pipes. The meter and Valves shall be fixed in a position by means of connecting pipes, jam nut and socket etc. The stop cock shall be fixed near the inlet of the water meter. The paper disc inserted in the ripples of the meter shall be removed. And the meter shall be installed exactly horizontally or vertically in the flow line in the direction shown by the arrow cast on the body of the meter. Care shall be taken to not disturb the factory seal of the meter. Wherever the meter shall be fixed to a newly fitted pipeline, the pipeline shall have to be completely washed before fitting the meter.

### 18.8.8 Testing

All water supply system shall be tested to Hydrostatic pressure test. Maximum operating pressure at varying degree of temperature is given in Table 18.15:-

**TABLE 18.15**

| Sl. No. | Temperature | SDR 11       | SDR 7.4      |
|---------|-------------|--------------|--------------|
|         |             | Pressure MPa | Pressure MPa |
| (i)     | 10          | 1.91         | 3.02         |
| (ii)    | 20          | 1.63         | 2.58         |
| (iii)   | 30          | 1.37         | 2.17         |
| (iv)    | 40          | 1.15         | 1.84         |
| (v)     | 50          | 0.98         | 1.55         |
| (vi)    | 60          | 0.82         | 1.28         |
| (vii)   | 70          | 0.62         | 0.98         |
| (viii)  | 80          | 0.39         | 0.62         |
| (ix)    | 95          | 0.27         | 0.4          |

The pressure test is performed in 3 steps being preliminary test, main test and final test. For the preliminary test a pressure which is 1.5 times higher than the possible working pressure is applied and this is repeated two times in 30 minutes with intervals of 10 minutes. After a test period of 30 minutes, the test pressure must not be dropped more than 0.6 bar and no leak must occur. Main test follows the preliminary test. Test time is two hours, in doing so the test pressure taken from the preliminary test must not have fallen more than 0.2 bar. After completion of these tests, the final test comes which has to be done under a test pressure of 10 bars and 5 bar in the interval of 15 minutes. Between the respective test courses, pressure has to be removed.

All leaks and defects in joints revealed during the testing shall be rectified and got approved at site by retest. Piping required subsequent to the above pressure test shall be retested in the same manner.

System may be tested in sections and such sections shall be entirely checked on completion of connection to the overhead tanks or pumping system or mains. In case of improper circulation, the contractor shall rectify the defective connections. He shall bear all expenses for carrying out the above rectifications including the tearing up and refinishing of floors and walls as required.

After commissioning of the water supply system, contractor shall test each valve by closing and opening it a number of times to observe if it is working efficiently. Valves which are not working efficiently shall be replaced by new ones.

### 18.8.9 Measurements

The net length of pipes as laid or fixed shall be measured in running meters correct to a cm for the finished work, which shall include PP -R pipe and fittings including plain fittings and Chrome Plated Brass Threaded fittings. Deductions for the length of valves shall be made. The cost includes cutting chases in the masonry wall and making good the same, trenching, refilling and testing of joints. The cost of gate valves/ wheel valves/ union shall be paid for separately.

## 18.9 CHLORINATED POLYVINYL CHLORIDE (CPVC) PIPES

**18.9.1** CPVC pipes & fittings used in hot & cold potable water distribution system shall conform to requirement of IS 15778. The material from which the pipe is produced shall consist of chlorinated polyvinyl chlorides. The polymer from which the pipe compounds are to be manufactured shall have chlorine content not less than 66.5%.

The internal and external surfaces of the pipe shall be smooth, clean and free from grooving and other defects. The pipes shall not have any detrimental effect on the composition of the water flowing through it.

Diameter and wall thickness of CPVC pipes are as per given in Table 18.16 below.

**TABLE 18.16**

| Sl.No  | Nominal size | Nominal outer diameter | Mean Outside Diameter |       | Outer diameter at any point |       | Wall Thickness  |     |      |                 |      |      |
|--------|--------------|------------------------|-----------------------|-------|-----------------------------|-------|-----------------|-----|------|-----------------|------|------|
|        |              |                        | Max                   | Min   | Max                         | Min   | Class 1, SDR 11 |     |      | Class 3, SDR 17 |      |      |
|        |              |                        |                       |       |                             |       | Avg. Max        | Min | Max  | Avg. Max        | Min  | Max  |
| (1)    | (2)          | (3)                    | (4)                   | (5)   | (6)                         | (7)   | (8)             | (9) | (10) | (11)            | (12) | (13) |
| (i)    | 15           | 15.9                   | 15.8                  | 16.0  | 15.8                        | 16.0  | 2.2             | 1.7 | 2.2  | -               | -    | -    |
| (ii)   | 20           | 22.2                   | 22.1                  | 22.3  | 22.0                        | 22.4  | 2.5             | 2.0 | 2.5  | -               | -    | -    |
| (iii)  | 25           | 28.6                   | 28.5                  | 28.7  | 28.4                        | 28.8  | 3.1             | 2.6 | 3.1  | -               | -    | -    |
| (iv)   | 32           | 34.9                   | 34.8                  | 35.0  | 34.7                        | 35.1  | 3.7             | 3.2 | 3.7  | -               | -    | -    |
| (v)    | 40           | 41.3                   | 41.2                  | 41.4  | 41.1                        | 41.5  | 4.3             | 3.8 | 4.3  | -               | -    | -    |
| (vi)   | 50           | 54.0                   | 53.9                  | 54.1  | 53.7                        | 54.3  | 5.5             | 4.9 | 5.5  | -               | -    | -    |
| (vii)  | 65           | 73.0                   | 72.8                  | 73.2  | 72.2                        | 73.8  | -               | -   | -    | 4.8             | 4.3  | 4.8  |
| (viii) | 80           | 88.9                   | 88.7                  | 89.1  | 88.1                        | 89.7  | -               | -   | -    | 5.9             | 5.2  | 5.9  |
| (ix)   | 100          | 114.3                  | 114.1                 | 114.5 | 113.5                       | 115.1 | -               | -   | -    | 7.5             | 6.7  | 7.5  |
| (x)    | 150          | 168.3                  | 168.0                 | 168.6 | 166.5                       | 170.1 | -               | -   | -    | 11.1            | 9.9  | 11.1 |

**Notes**

- For CPVC pipes SDR is calculated by dividing the average outer diameter of the pipe in mm by the minimum wall thickness in mm. If the wall thickness calculated by this formula is less than 1.52 mm, it shall be increased to 1.52 mm. The SDR values shall be rounded to the nearest 0.5.

**18.9.2 Dimensions of Pipes**

The outside diameter, outside diameter at any point and wall thickness shall be as given in Table 18.16.

**18.9.2.1 Diameter :** The outside diameter and outside diameter at any point as given in Table 18.16 shall be measured according to the method given in IS 12235 (part 1).

**18.9.2.2 Diameter at any point :** The difference between the measured maximum outside diameter and measured minimum outside diameter in the same cross-section of pipe (also called tolerance on ovality) shall not exceed the greater of the following two values:

- 0.5 mm, and
- 0.012  $d_n$  rounded off to the next higher 0.1 mm.

**18.9.2.3 Wall Thickness :** The wall thickness of the pipes shall be as given in Table 18.16. Wall thickness shall be measured by any of the three methods given in IS 12235 (part 1). To check the conformity of the wall thickness of the pipe throughout its entire length, it is necessary to measure the wall thickness of the pipe at any point along its length. This shall be done by cutting the pipe at any point along its length and measuring the wall thickness as above. Alternatively, to avoid destruction of the pipe, non destructive testing methods such as the use of ultrasonic wall thickness measurement gauges shall be used at any four points along the length of the pipe.

**Tolerance on Wall Thickness**

- For pipes of minimum wall thickness 6 mm or less, the permissible variation between the minimum wall thickness ( $e_{Min}$ ) and the wall thickness at any point (e), ( $e - e_{Min}$ ) shall be positive in the form of +y, where  $y=0.1 e_{Min}+0.2$  mm.
- For pipes of minimum wall thickness greater than 6mm, the permissible variation of wall thickness shall again be positive in the form of +y, where y would be applied in two parts.
- The average wall thickness shall be determined by taking at least six measurements of wall thickness round the pipe and including both the absolute minimum and absolute maximum measured values. The tolerance applied to this average wall thickness from these measurements shall be within the range  $0.1 e_{Min}+0.2$  mm (see Table 18.16).
- The maximum wall thickness at any point shall be within the range  $0.15e_{Min}$  (see Table 18.16).
- The results of these calculations for checking tolerance shall be rounded off to the next higher 0.1 mm.

**18.9.2.4 Effective Length (Le) :** If the length of a pipe is specified, the effective length shall not be less than that specified. The preferred effective length of pipes shall be 3, 5 or 6 m. The pipes may be supplied in other lengths where so agreed upon between the manufacturer and the purchaser.

**18.9.3 Pipe Ends**

The ends of the pipes meant for solvent cementing shall be cleanly cut and shall be reasonably square to the axis of the pipe or may be chamfered at the plain end.

**18.9.4 Physical and Chemical Characteristics**

**18.9.4.1 Visual Appearance :** The colour of the pipes shall be off-white. Slight variations in the appearance of the colour are permitted.

The internal and external surface of the pipe shall be smooth, clean and free from grooving and other defects.

**18.9.4.2 Opacity :** The wall of the plain pipe shall not transmit more than 0.1 per cent of the visible light falling on it when tested in accordance with IS 12235 (Part 3).

**18.9.4.3 Effect on Water :** The pipes shall not have any determinate effect on the composition of the water flowing through them, when tested as per 10.3 of IS 4985.

**18.9.4.4 Reversion Test :** When tested by the method prescribed in IS 12235 (Part 5/ Sec 1 and Sec 2), a length of pipe 200 ±20 mm long shall not alter in length by more than 5 per cent.

**18.9.4.5 Vicat Softening Temperature :** When tested by the method prescribed in IS 12235 (part 2), the Vicat softening temperature of the specimen shall not be less than 110°C.

**18.9.4.6 Density :** When tested in accordance with IS 12235 (Part 14), the density of the pipes shall be between 1450kg/m<sup>3</sup> and 1650kg/m<sup>3</sup>.

**18.9.5 Mechanical Properties**

**18.9.5.1 Hydrostatic Characteristics :** When subject to internal hydrostatic pressure test in accordance with the procedure given in IS 12235 (part 8/Sec 1), the pipe shall not fail during the prescribed test duration. The temperatures, duration and hydrostatic (hoop) stress for the test shall conform to the requirements given in Table 18.17. The test shall be carried out not earlier than 24 h after the pipes have been manufactured.

**TABLE 18.17  
Requirements of Pipes for Internal Hydrostatic Pressure Test  
(Clause 18.9.5.1)**

| Sl. No. | Test       | Test Temperature Min | Test Period | Hydrostatic (Hoop) Stress        |
|---------|------------|----------------------|-------------|----------------------------------|
|         |            | °C                   | h           | MPa                              |
| (1)     | (2)        | (3)                  | (4)         | (5)                              |
| (i)     | Acceptance | 20                   | 1           | 43.0                             |
| (ii)    | Type       | 95                   | 165         | 5.6                              |
| (iii)   | Type       | 95                   | 1000        | 4.6                              |
| (iv)    | Type       | 95                   | 8760        | 3.6 (Test for thermal stability) |

**18.9.5.2 Thermal Stability by Hydrostatic Pressure Testing :** When subject to internal hydrostatic pressure test in accordance with the procedure given in IS 12235 (Part 8/Sec 1) and as per requirement given in Table 18.17, Sl. No. (iv), the pipe shall not burst or leak during the prescribed test duration.

**18.9.5.3 Resistance to External Blow at 0°C :** When tested by the method prescribed in IS 4985, with classified striker mass and drop height as given in Table 18.18, the pipe shall have a true impact rate of not more than 10 per cent.



**TABLE 18.18**  
**Classified Striker Mass and Drop Height Conditions for the Falling Weight Impact Test**  
**(Clause 18.9.5.3)**

| Sl. No. | Nominal Pipe Size | Mass of Falling Weight | Falling Height |
|---------|-------------------|------------------------|----------------|
|         | mm                | Kg                     | mm             |
| (1)     | (2)               | (3)                    | (4)            |
| (i)     | 15                | 0.5±0.5%               | 300±10         |
| (ii)    | 20                | 0.5±0.5%               | 400±10         |
| (iii)   | 25                | 0.5±0.5%               | 500±10         |
| (iv)    | 32                | 0.5±0.5%               | 600±10         |
| (v)     | 40                | 0.5±0.5%               | 800±10         |
| (vi)    | 50                | 0.5±0.5%               | 1000± 10       |
| (vii)   | 65                | 0.8±0.5%               | 1000±10        |
| (viii)  | 80                | 0.8±0.5%               | 1200±10        |
| (ix)    | 100               | 1.0±0.5%               | 1600±10        |
| (x)     | 150               | 1.6±0.5%               | 2000±10        |

**18.9.5.4 Flattening Test :** When tested by the method prescribed in IS 12235 (part 19), pipe shall show no signs of cracking, splitting and breaking.

**18.9.5.5 Tensile Strength :** When tested by the method prescribed in IS 12235 (Part 19), the tensile strength at yield shall not be less than 50 MPa at  $27 \pm 2^\circ\text{C}$ .

#### 18.9.6 Sampling and Criteria for Conformity

The sampling procedure and criteria for conformity shall be as given in Annexure F.

#### 18.9.7. Marking

**18.9.7.1** Each pipe shall be clearly and indelibly marked in ink/paint or hot embossed on white base at intervals of not more than 3 m. The marking shall show the following:

- (a) Manufacturer's name or trade-mark
- (b) Outside diameter,
- (c) Class of pipe and pressure rating, and
- (d) **Batch** or lot number

**18.9.7.2 BIS Certification Marking :** Each pipe may also be marked with the Standard Mark.

#### 18.9.8 Fittings

The fittings shall be as follows:

- (a) Plain CPVC solvent cement fittings from size 15 mm to 160 mm.
- (b) Brass threaded fittings.
- (c) Valve from size 15 mm to 160 mm
- (d) *Brass Threaded Fittings:* All types of one end brass threaded male/female adaptors in various fittings like coupler, socket, elbow, tee are available for transition to other plastic/metal piping and for fixing of CP fittings. Ball, Gate valves in CPVC are available in all dimensions. All fittings shall carry the following information:
  - (1) Manufacturer's name/trade mark.
  - (2) Size of fitting

#### 18.9.9 Piping Installation Support and Spacing

**18.9.9.1 Concealed Piping:** Pipes can be concealed in chases. The pipes and fitting are to be pressure tested prior to concealing the chases. To maintain alignment of CP fittings while joining, all alignment of fittings and pipe shall be done correctly. DO NOT USE NAILS FOR HOLDING OF PIPES IN THE CHASES.



**18.9.9.2 External Installations:** For pipes fixed in the shafts, ducts etc. there should be sufficient space to work on the pipes. Pipes sleeves shall be fixed at a place the pipe is passing through a wall or floor so as to allow freedom for expansion and contraction. Clamping of the pipe is done to support it while allowing the freedom for movement.

All pipes exposed to sunlight shall be painted with a water based acrylic paint emulsion to enhance UV protection. Pipes in trenching shall be laid in accordance to the Good Plumbing practices followed for Metal piping.

**Recommended Support Spacing (Distance between Pipe Clamps Horizontal Support)**

| Pipe Size      | Horizontal Support (In meters) |      |      |      |
|----------------|--------------------------------|------|------|------|
|                | Temperature                    |      |      |      |
|                | 23°C                           | 38°C | 60°C | 82°C |
| 16 mm (1/2")   | 1.22                           | 1.22 | 1.07 | 0.92 |
| 20 mm (3/4")   | 1.53                           | 1.37 | 1.22 | 0.92 |
| 25 mm (1/0")   | 1.68                           | 1.3  | 1.37 | 0.92 |
| 32 mm (1 1/4") | 1.83                           | 1.68 | 1.53 | 1.22 |
| 40 mm (1 1/2") | 1.98                           | 1.83 | 1.68 | 1.22 |
| 50 mm (2")     | 2.29                           | 2.14 | 1.98 | 1.22 |

**18.9.9.3 Expansion LOOP:** CPVC systems, like all piping materials, expand and contract with changes in temperatures. CPVC pipes shall expand 7.5 cm per 30 m length for a 40°C temperature change. Expansion does not vary with Pipe size. Thermal expansion can be generally be accommodated at changes in direction. On a long straight run, an offset or loop based on the following chart is required.

| Nominal Pipe Size | Length of Run (Meter), Loop length in cms. |          |          |          |          |
|-------------------|--|----------|----------|----------|----------|
|                   | 6 metre                                    | 12 metre | 18 metre | 24 metre | 30 metre |
| 15 mm             | 43   | 56       | 69       | 79       | 86       |
| 20 mm             | 48   | 66       | 81       | 91       | 104      |
| 25 mm             | 53   | 74       | 91       | 104      | 117      |
| 32 mm             | 58   | 81       | 102      | 117      | 130      |
| 40 mm             | 63   | 89       | 109      | 127      | 142      |
| 50 mm             | 71   | 102      | 124      | 145      | 63       |

**18.9.10 Testing**

All water supply systems shall be tested to hydrostatic pressure test. The pressure tests are similar to the test pressure used for other plastic/metal pipes. System may be tested in sections and such section shall be entirely checked on completion of connection to the overhead tank or pumping system or mains.

**18.9.11 Measurements**

The net length of pipes as laid or fixed shall be measured in running meters correct to a cm for the finished work, which shall include CPVC pipe and fittings including plain and Brass threaded fittings and jointing solvent cement.

**18.10 PE-AL-PE PIPES**

**18.10.1** The PE-AL-PE pipes are bonded, multilayer pipes consisting of metal aluminium and polyethylene i.e. metallic pipe bonded with adhesive both internally and externally by polyethylene coating. The layers of PE-AL-PE pipes are:-

- (i) The interior layer of polyethylene
- (ii) The adhesive layer
- (iii) Aluminium tube

- (iv) The adhesive layer
- (v) The external layer of polyethylene

Polyethylene composite pressure pipes have welded aluminium tube reinforcement between inner and outer polyethylene layers, inner and outer polyethylene layer being bonded to aluminium tube by melt adhesive and are manufactured as per IS 15450

The specially manufactured compression joints fittings should be used for PE -AL-PE pipes which are available in 3 types i.e. brass, composite and composite external sealing. Either of these fittings should be used. The external sealing fittings should be used only for cold water applications.

- 18.10.2** (i) Polyethylene compounds shall conform to IS 7328 as follows:
- (a) PEEWA 45 T006 for black pipes and
  - (b) PEELA 45 T006 for coloured pipes.

- (ii) Aluminium shall have following properties:
- (a) Minimum elongation: 20%
  - (b) Ultimate tensile strength: 100 MPa.
- The aluminium strip shall have nominal thickness as specified in Table 18.19 (i). Tolerances on all thickness for all sizes shall be (+) 0.02 mm.

**TABLE 18.19 (i)**  
**Aluminium Thickness and Tolerances for PE-AL-PE Pipe**

| S. No. | Nominal Pipe Size (mm) | Nominal Aluminium Thickness (mm) |
|--------|------------------------|----------------------------------|
| (i)    | 1216                   | 0.20                             |
| (ii)   | 1620                   | 0.25                             |
| (iii)  | 2025                   | 0.25                             |
| (iv)   | 2532                   | 0.30                             |
| (v)    | 3240                   | 0.30                             |
| (vi)   | 4050                   | 0.30                             |

- (iii) Dimensions of pipes shall be as given in Table 18.19 (ii).

**TABLE 18.19 (ii)**

| S. No. | Nominal pipe size (mm) | Nominal outside diameter (OD) (mm) | Total wall thickness |              | Outer PE layer Thickness Minimum (mm) |
|--------|------------------------|------------------------------------|----------------------|--------------|---------------------------------------|
|        |                        |                                    | Minimum (mm)         | Maximum (mm) |                                       |
| (i)    | 1216                   | 16                                 | 1.75                 | 2.00         | 0.40                                  |
| (ii)   | 1620                   | 20                                 | 2.00                 | 2.25         | 0.40                                  |
| (iii)  | 2025                   | 25                                 | 2.45                 | 2.70         | 0.40                                  |
| (iv)   | 2532                   | 32                                 | 2.80                 | 3.20         | 0.40                                  |
| (v)    | 3240                   | 40                                 | 3.40                 | 3.80         | 0.40                                  |
| (vi)   | 4050                   | 50                                 | 4.00                 | 4.40         | 0.40                                  |

- (iii) Dimensions of pipes shall be as given in Table 18.19 (ii).
- (iv) The PE-AL-PE composite pipe shall be pressure rated for maximum water pressures of 1.38 MPa at 23°C and 1.10 MPa at 60°C.

### 18.10.3 Jointing

While jointing PE-AL-PE pipes, following steps are required to be taken to ensure a leak proof and strong pipe joint:-

- (a) Cut the pipe square by cutter to the required and proper length.
- (b) Select the fitting to be used and dismantle its nuts and split rings.
- (c) Place the nut and split ring over the pipe. Ensure that 'O' rings are in proper position of insert.
- (d) Prepare the end of pipe to be jointed for roundness and chamfer by using beveling tool. Push the pipe over the insert and inside the support groove fully.
- (e) Push the split ring and nut towards connector till split ring touches the support groove.
- (f) Tighten the nut over connector with spanner.

If the joints are required to be dismantled for any reason, the 'O' ring and split ring should be inspected before reassembling the joint for any damage. If any ring is found damaged, the same should be replaced. All other components can be reused. The joint sealing with fittings is done by silicone rubber ring. No thread sealing is involved. Tightening of the nuts is required only for compressing the split ring over the pipe, hence excessive tightening of the nuts is to be avoided. In case threading is required for fixing valves and fixtures, then select the fittings already having male or female thread as per the requirement.

### 18.10.4 Fixing in Portion of PE-AL-PE Pipes

For installation of PE-AL-PE pipes and fittings, following steps are required to be taken to ensure easy and faster installation:-

**18.10.4.1** Measure the exact length of pipe required from fitting to fitting.

**18.10.4.2** Cut pipe to required length by using PE-AL-PE pipe cutter to ensure clean and square cut. If the cut is not proper then the joint will not be proper/leak proof.

**18.10.4.3** Use external bending spring for straightening of the PE-AL-PE pipes which are available in coils. If there are any bends in between then insert the external bending spring over the pipe and bend it to required angle. Move the spring after bending to next bending location. After putting the pipe in position completely, remove the spring. If the ends of pipes are required to be bent then the external bending spring may not support the pipe fully. In such cases, use internal bending spring. Use of bending springs facilitates bending of pipe to desired radius without causing any deformation to the pipe.

**18.10.4.4** While connecting the fitting to the end of the pipe, follow the jointing procedure.

The PE-AL-PE pipe can be bent easily to the required shape. The bending shall be done in such a way that the bending radius is not less than 5 times the outer diameter of the pipe. As the pipe stays in shape, elbows are generally not required. Due to the unique jointing system, unions are not at all required. Bending of PE-AL-PE pipe in 'L' shape is not recommended. Use elbow in case it is absolutely necessary.

**18.10.4.5** PE-AL-PE pipe can be installed in both internal and external work. For concealed work the walls can be recessed by hand or mechanical router for speed. Where PE-AL-PE pipe are installed on the surface, the maximum clipping center should be kept as Table 18.20.

**Table 18.20**

| <i>Pipe size</i> | <i>Horizontal<br/>(mm)</i> | <i>Vertical<br/>(mm)</i> |
|------------------|----------------------------|--------------------------|
| 1216             | 800                        | 1000                     |
| 1620             | 800                        | 1000                     |
| 2025             | 1000                       | 1200                     |
| 2532/3250        | 1200                       | 1500                     |

The pipes installed on surface must have two additional clamps at fittings other than as specified above.

**18.10.4.6** It is necessary to provide clip/hook at the threaded fittings.

**18.10.4.7** Only Teflon Tape should be used on threads instead of 'Dhaaga/ Safeda'. While for fittings, specially designed rubber "Seal" should be used.

**18.10.5** For pressure testing the pipeline system, specially designed test plugs are to be used in female thread elbows instead of ordinary GI nipples with MS plugs before covering the pipes in chases.

**18.10.6** Diameter of pipes should be increased from 16 mm OD to 20 mm OD when the user points exceed three. The head recommended for flush valve in gravity flow system is minimum 10 meters for 3240 mm size pipe. For optimum calculations and further design IS 15450 and "manufacturer's plumbing design guidelines" should be referred.

#### **18.10.7 Storing Precautions**

**18.10.7.1** PE -AL- PE pipe should be stacked carefully so as to prevent them from falling or causing damage with any external sharp edged material. PE-AL-PE pipe is a tough material but needs greater protection from accidental damages when installed in comparison to metallic pipes.

**18.10.7.2** Where PE-AL- PE pipe is to be connected to heavy items such as pumps or valves it is likely to impose undue strain in the pipes, hence the pump or valve should be supported directly using the support bracket.

**18.10.7.3** The PE-AL-PE pipe are malleable, hence these should be protected from any heavy load/ impact and drilling etc. Where these pipes are provided under the ground, adequate cover as per IS 15450 should be provided.

**18.10.8** The maximum allowable parameters for various components of PE-AL-PE piping system are given in Table 18.21.

**TABLE 18.21**

| <i>Fluid</i> | <i>Service temperature deg 'C'</i> | <i>Maximum allowable service pressure in bar</i> |                                       |   |                                   |
|--------------|------------------------------------|--|---------------------------------------|---|-----------------------------------|
|              |                                    | <i>PE-AL-PE pipe</i>                             | <i>Fitting Internal Sealing Brass</i> | <i>Fitting Internal Sealing Composite</i> | <i>Fitting end Seal Composite</i> |
| Water        | Ambient                            | 15   | 13                                    | 10  | 10                                |
|              | 65                                 | 10   | 10                                    | 10  | -                                 |
|              | 80                                 | 10   | 10                                    | 4   | -                                 |

Before the pipes are covered or put to use, these should be tested for any leakage as per the following table:-

The requirement of hydraulic test pressure are given in the following table at 20°C & 60°C temperature respectively using water.

**TABLE 18.22**

| <i>Description</i> | <i>Pressure in MPa</i>    |                            |
|--------------------|---------------------------|----------------------------|
|                    | <i>1 Hour Test (20°C)</i> | <i>10 Hour Test (60°C)</i> |
| Nominal Pipe Size  |                           |                            |
| 1216               | 3.0                       | 2.50                       |
| 1620               | 2.70                      | 2.50                       |
| 2025               | 2.60                      | 2.50                       |
| 2532               | 2.30                      | 2.10                       |
| 3240               | 2.20                      | 2.00                       |

### **18.11 MAKING CONNECTION OF G.I. DISTRIBUTION BRANCH WITH G.I. MAIN**

#### **18.11.1 Preliminary Work**

A pit of suitable dimensions shall be dug at the point where the connection is to be made with the main and earth removed up to 15 cm below the main. The flow of water in the water main shall also be disconnected by closing the sluice or wheel valves on the mains.

#### **18.11.2 Making Connection**

For cutting and jointing 18.6.2 and 18.6.3 shall apply. The G.I. main shall first be cut. Water if any collected in the pit shall be bailed out and, ends of the G.I. pipes threaded. The connection of distribution pipe shall then be made after fixing G.I. tee of the required size to the G.I. main and fittings such as Jam nut, G.I. socket connecting piece etc.

#### **18.11.3 Testing of Joints**

After laying and jointing, the pipes and fittings shall be inspected under working condition of pressure and flow. Any joint found leaking shall be redone and all leaking pipes removed and replaced without extra payment.

The pipes & fittings after they are laid shall be tested to hydraulic pressure of 6 kg./sq.cm. (60 m). The pipes shall be slowly and carefully charged with water allowing all air to escape and avoiding all shock of water hammer. The draw of laps and stop cocks shall then be closed and specified hydraulic pressure shall be applied gradually. Pressure gauge must be accurate and preferably should have been recalibrated before the test. The test pump having been stopped, the test pressure should be maintained without loss for at least half an hour. The pipes and fittings shall be tested in sections as the work of laying proceeds, having the joints exposed for inspection during the testing.

#### **18.11.4 Finishing**

The portion of the pipe in the pit shall be painted with bitumastic paint and encased with sand 15 cm all-round. The pit shall be filled with earth in level with the original ground surface watered, rammmed and the area dressed.

#### **18.11.5 Measurements**

The work of making connections shall be enumerated.

#### **18.11.6 Rate**

The rate shall include the cost of labour and materials involved in all the operations described above.

## **18.12 FIXING BRASS AND GUN METAL WATER FITTINGS**

**18.12.0** The fitting shall be fully examined and cleared of all foreign matter before being fixed. The fitting shall be fitted in the pipe line in a workman like manner. The joints between fittings and pipes shall be leak-proof when tested to a pressure of 17.5 kg/sq.cm. The defective fittings and joints shall be replaced or redone.

### **18.12.1 Measurements**

Fittings shall be enumerated.

### **18.12.2 Rate**

The rate shall include cost of all the material and labour involved in all the operation described above.

## **18.13 FIXING FERRULES**

**18.13.1** For fixing ferrule the empty main shall be drilled and tapped at 45 degree to the vertical and the ferrule screwed in. The ferrule must be so fitted that no portion of the shank shall be left projecting within the main into which it is fitted.

### **18.13.2 Measurements**

Ferrule shall be enumerated.

### **18.13.3 Rate**

The rate shall include the cost of all materials and labour involved in fixing the ferrule.

## **18.14 INSTALLATION OF FIRE HYDRANT**

**18.14.1** The hydrant shall be fully examined and cleared of all foreign matter before being fixed. The fixing shall be done on the water main which shall be of minimum 80 mm dia. The flanged end of the hydrant shall be fixed to the flanged outlet of a tee in the water main by means of bolts, nuts and 3 mm rubber insertion or chemically treated compressed fiber board 1.5 mm minimum thickness and of weight not less than 0.183 gm. per sq.cm. This can also be fixed by means of flanged tail piece which may be connected to the water main by C.I. specials.

### **18.14.2 Measurements**

Fire hydrant shall be enumerated.

### **18.14.3 Rate**

The rate shall include the cost of materials and labour involved in all the operations described above against relevant item of work.

## **18.15 INSTALLATION OF SLUICE VALVE**

**18.15.1** The valve shall be fully examined and cleared of all foreign matter before being fixed. The fixing of the valve shall be done by means of bolts, nuts and 3 mm rubber insertions or chemically treated compressed fiber board 1.5 mm minimum thickness and of weight not less than 0.183 gm./sq.cm. with the flanges of spigot and the socketed tail pieces drilled to the same specification in case of S&S pipes and with flanges in case of flanged pipes. The tail pieces shall conform to IS 1938. These shall be jointed to the pipe line by means of lead caulked joints.

### **18.15.2 Measurements**

Sluice valve shall be enumerated.

### **18.15.3 Rate**

The rate shall include the cost of material and labour involved in all the operations described above.

### **18.16 INSTALLATION OF WATER METER AND STOP VALVE (FIG. 18.3 and 18.4)**

**18.16.0** The G.I. line shall be cut to the required length at the position where the meter and stop cock are required to be fixed. The ends at the pipe shall then be threaded. The meter and stop cock shall be fixed in position by means of connecting pipes, G.I. jam nut and socket etc. The stop cock shall be fixed near the inlet of the water meter. The paper disc inserted in the nipples of the meter shall be removed and the meter installed exactly horizontal or vertical in the flow line in the direction shown by the arrow cast on the body of the meter. Care shall be taken that the factory seal of the meter is not disturbed. Wherever the meter shall be fixed to a newly fitted pipe line, the pipe line shall have to be completely washed before fitting the meter. For this purpose a piece of pipe equal to the length of the meter shall be fitted in the proposed position of the meter in the new pipe line. The water shall be allowed to flow completely to wash the pipe line and then the meter installed as described above by replacing the connecting piece.

#### **18.16.1 Testing of Joints**

Testing of joints shall be done as described in 18.6.6.

#### **18.16.2 Measurements**

The work of fixing meters and stop cocks shall be counted in numbers separately according to the diameters.

#### **18.16.3 Rate**

The rate shall include the cost of labour and materials involved in all the operations described above excluding the cost of stop cock and water meter.

### **18.17 FIXING SURFACE BOX (FIG. 18.6)**

**18.17.1** The C.I. surface box shall be fixed on the top of masonry chamber in plain or reinforced cement concrete 1:2:4 (1 cement: 2 coarse sand: 4 graded stone aggregate 20 mm nominal size) as the case may be.

#### **18.17.2 Measurements**

Masonry chambers shall be enumerated under the relevant items.

#### **18.17.3 Rate**

The rate shall include the cost of materials and labour involved in all the operations described above, except the excavation in saturated soil, soft or decomposed and hard rock if met with. The difference of cost, between ordinary soil and saturated soil or soft or decomposed or hard rock as the case may be, shall be paid for separately.

### **18.18 POLYETHYLENE WATER STORAGE TANKS**

#### **18.18.1 Material**

Polyethylene used for manufacture of tanks and manhole lids may be high density (HDPE), low density (LDPE) or linear low density (LLDPE) and shall conform to IS 10146. Polyethylene shall be compounded with carbon black so as to make the tank resistant to ultra violet rays from the sun. The percentage of carbon black content in polyethylene shall be  $2.5 \pm 0.5$  percent and it shall be uniformly distributed. The materials used for the manufacture of tank, manhole lid and fittings shall be such that they neither contaminate the water nor impart any taste, colour, odour or toxicity to water.

#### **18.18.2 Manufacture and Finish**

The tanks shall be manufactured by rotational moulding process. Each tank and the manhole lid shall be single piece having arrangement for fixing and locking the manhole lid with the tanks. Excess material at the mould parting line and near the top rim shall be neatly cut and finished. The internal and external surface of the tanks shall be smooth, clean and free from hidden internal defects like air bubbles, pit and metallic or other foreign material inclusion. Capacity of the tank, minimum weight of the empty tank (without manhole lid) and the manufacture brand name shall be embossed on the top surface of the tank near manhole.

### 18.18.3 Shape, Size and Capacity

The tank shall be cylindrical vertical with closed top having a manhole. Diameter and height of the tank of various capacities shall be as per manufacturer's specifications and a clearance of  $\pm 3$  percent shall be permitted on these dimensions. Capacity of the tank or up to the bottom of the inlet location whichever is less. Capacity of the tank shall be specified. Extra capacity if any shall be ignored.

### 18.18.4 Weight and Wall Thickness

Minimum weight of the empty tank (exclusive of manhole lid fittings) and the minimum wall thickness of top, bottom and sides shall be specified in Table 18.23. Wall thickness shall be checked beyond 150 mm of the edge where the direction the plane of tank surface changes.

### 18.18.5 Installation and Fittings

The flat base of the tank shall be fully supported over its whole bottom area on a durable rigid flat and level platform sufficiently strong to stand without deflection the weight of the tank when fully filled with water. Depending upon the capacity and location tanks may be suitably anchored as per the directions of the Engineer-in-Charge. For inlet, outlet and other connections fully threaded GI, HDPE or PVC connections with hexagonal check nuts and washers on either side of the tank wall shall be provided. Holes for threaded connections shall be drilled and not punched. Pipes entering or leaving the tank shall be provided with unions and suitably supported on a firm base to avoid damage to the tank walls.

### 18.18.6 Manhole Lid

The lid shall rest evenly and fit over the rim of the manhole so as to prevent the ingress of any foreign matter into the tank. The lid shall be provided with suitable arrangement for locking it with the tank.

**18.18.7** The tank and its components shall conform to the local bye-laws for preventions of mosquito menace.

### 18.18.8 Measurements

Dimensions shall be measured to the nearest cm. and weight of the empty tank shall be recorded to the nearest 100g. Capacity of the tank as defined in 18.18.3 shall be calculated to the nearest litre.

**TABLE 18.23**

| S.No | Capacity | Minimum Wall Thickness | Minimum Weight of Empty Tank |
|------|----------|------------------------|------------------------------|
|      | litres   | mm                     | kg                           |
| 1    | 2        | 3                      | 4                            |
| 1.   | 200      | 4.4                    | 7.8                          |
| 2.   | 300      | 4.4                    | 9.0                          |
| 3.   | 400      | 5.5                    | 15.0                         |
| 4.   | 500      | 6.0                    | 18.0                         |
| 5.   | 700      | 6.6                    | 23.5                         |
| 6.   | 1000     | 7.0                    | 33.0                         |
| 7.   | 1250     | 7.0                    | 40.0                         |
| 8.   | 1500     | 7.0                    | 47.0                         |
| 9.   | 1700     | 7.0                    | 54.0                         |
| 10.  | 2000     | 8.2                    | 64.0                         |
| 11.  | 2500     | 8.2                    | 81.0                         |
| 12.  | 3000     | 8.8                    | 96.0                         |
| 13.  | 4000     | 10.4                   | 138.0                        |
| 14.  | 5000     | 10.7                   | 191.0                        |
| 15.  | 6000     | 10.7                   | 209.0                        |
| 16.  | 7500     | 10.7                   | 250.0                        |
| 17.  | 10000    | 11.5                   | 363.0                        |
| 18.  | 15000    | 11.5                   | 550.0                        |
| 19.  | 20000    | 13.2                   | 814.0                        |



### **18.18.9 Rates**

The rate shall include the cost of the tank, manhole lid, carriage and delivery at the place specified. Hoisting, installation, fittings, platform and anchoring shall be payable separately.

## **18.19 TUBE WELLS WITH HAND PUMPS**

### **18.19.1 Casing Pipe**

The casing pipe shall be of M.S. or W.I. of 100 mm dia. and strong enough to stand hammering and vibrations to which it is subjects.

### **18.19.2 Filter and Brass Strainer**

The filter shall consist of a G.I. pipe of the required diameter with 15 mm diameter holes covered with brass strainer both inside and outside. It shall have a driving point riveted or welded to it.

### **18.19.3 Hand Pump**

This shall be of approved quality. It shall be complete with necessary bolt and nuts for joining to the masonry or concrete base.

## **18.20 CUTTING HOLES IN WALL UPTO 30 × 30 CM**

**18.20.0** Square holes of size as specified or as directed by the Engineer-in-Charge shall be cut in the masonry. Any damage to the adjoining portion or to any other item shall be made good as directed by the Engineer-in-Charge. All dismantled material shall be removed from the site.

### **18.20.1 Masonry Work**

Brick work etc. shall be made good by using the same class of brick, tile or stone masonry as was cut during the execution of work. The mortar to be used shall be cement mortar 1:4 (1 cement: 4 fine sand) or as directed by the Engineer-in-Charge.

### **18.20.2 Finishing**

Cement mortar in 1:4 mix (1 cement: 4 sand) shall be used for plastering or pointing, as may be required. Sand shall be fine or coarse, as used in the original work. The surface shall be finished with two or more coats of white wash, colour wash, distemper or painting as required but where the surface is not to be white washed, colour washed, distempered or painted; it shall be finished smooth with a floating coat of neat cement or as required to match with the surrounding surfaces.

### **18.20.3 Measurements**

The holes shall be enumerated.

### **18.20.4 Rate**

The rate shall include the cost of labour and materials required for all the operations described above.

## **18.21 CUTTING HOLES IN R.C.C. FLOORS (UPTO 15 × 15 CM)**

**18.21.0** Square holes of size as specified shall be cut in R.C.C. floor and roofs for passing drain pipe etc. Any damage to the adjoining portion or to any other item shall be made good as directed by the Engineer-in-Charge. All the dismantled material shall be removed from the site.

### **18.21.1 Cement Concrete**

After insertion of drain pipe etc. the hole shall be repaired with cement concrete 1:2:4 (1 cement: 2 coarse sand: 4 graded stone aggregate 20 mm nominal size) and the surface finished to match with the existing surface. The top and bottom shall be finished properly to make the joint leak proof. The specifications for cement concrete work and finishing etc. shall be the same as detailed under relevant sub-heads.

### **18.21.2 Measurements**

Holes shall be enumerated.

### **18.21.3 Rate**

The rate shall include the cost of labour and material required for all the operations described above except the pipe which shall be paid for separately.

## **18.22 CUTTING CHASES IN MASONRY WALLS**

### **18.22.1 Making Chases**

Chases are made in the walls for housing G.I. Pipes etc.

#### ***I. Cutting of chases in one brick thick and above load bearing walls :***

- (i) As far as possible services should be planned with the help of vertical chases. Horizontal chases should be avoided.
- (ii) The depths of vertical chases and horizontal chases shall not exceed one third and one sixth of the thickness of the masonry respectively.
- (iii) When narrow stretches of masonry (or short lengths of walls) such as between doors and windows, cannot be avoided, they should not be pierced with openings for soil pipes or waste pipes or timber joints, etc. Where there is a possibility of load concentration, such narrow lengths of walls shall be checked for stresses and high strength bricks mortar or concrete walls provided, if required.
- (iv) Horizontal chases when unavoidable should be located in the upper or lower one third of height of storey and not more than three chases should be permitted in any stretch of a wall. No continuous horizontal chase shall exceed one metre in length. Where unavoidable, stresses in the affected area should be checked and kept within the permissible limits.
- (v) Vertical chases should not be closer than 2 m in any stretch of a wall. These shall be kept away from bearings of beams and lintels. If unavoidable, stresses in the affected area should be checked and kept within permissible limits.
- (vi) Masonry directly above a recess, if under than 30 cm (Horizontal dimension) should be supported on lintel. Holes in masonry may be provided up to 30 cm width x 30 cm height without any lintel. In the case of circular holes in masonry, no lintel should be provided up to 40 cm in diameter.

#### ***II. Cutting of chases in half brick load bearing walls***

No chase shall be permitted in a half brick load bearing wall and as such no recessed conduits and concealed pipes shall be provided in half brick thick load bearing walls.

#### ***III. Cutting of chases in half brick non-loading bearing walls***

In case of non load bearing half brick walls services should be planned with the help of vertical chases. Horizontal chases should be provided only when unavoidable.

#### ***IV. Cutting of chases in stone masonry walls***

The provision (i) to (vi) under Sl. No. I are equally applicable to stone masonry walls also.

#### **Note:**

1. No inclined chase shall be permitted in brick masonry or stone masonry walls. In case inclined chases are unavoidable these shall be cut with written approval of the Engineer-in-Charge, and shall be repaired properly to his satisfaction. However, in half brick masonry wall, no inclined chase will be permitted.
2. Chases shall be made by chiseling out the masonry to proper line & depth. Any damage to the adjoining portion or to any other item shall be made good, as decided by the Engineer-in-Charge, for which no extra payment shall be made. All dismantled material shall be removed from site.

### **18.22.2 Filling Chases**

After G.I. Pipes etc. are fixed in chases, the chases shall be filled with cement concrete 1:3:6 (1 cement: 3 coarse sand: 6 graded stone aggregate 20 mm nominal size) or cement mortar 1:4 (1 cement: 4 coarse sand) as may be specified or otherwise directed by the Engineer-in-Charge and made flush with the masonry surface. The concrete surface shall be roughened with wire brushes to provide a key for plastering.

### **18.22.3 Measurements**

Chases shall be measured in running meter correct to a cm.

### **18.22.4 Rates**

The rate shall include the cost of labour the materials involved in all the operations described above excluding the cost of providing pipes etc. which shall be paid separately.

### **18.23 CP BRASS BIB COCK**

The CP brass bib cock shall be conforming to IS : 8931. The body shall be of chromium plated copper alloy and external and internal surfaces shall be clean, smooth and free from sand. The 15mm nominal bore shall be designated by the nominal bore of the pipe outlet to which the bib cocks are normally fitted.

The dimensions of body for Bib Cock shall be as per table given to IS : 8931. Each bib cock shall be legibly marked with the Manufacture's name and trade mark.

### **18.24 CP BRASS LONG NOSE BIB COCK**

The CP brass long nose bib cock shall be conforming to IS standards. The body shall be of chromium plated copper alloy and external and internal surfaces shall be clean, smooth and free from sand. The 15mm nominal bore shall be designated by the nominal bore of the pipe outlet to which the bib cocks are normally fitted.

The weight of long nose Bib Cock shall be less than 810 grams. Each bib cock shall be legibly marked with the Manufacture's name and trade mark.

### **18.25 CP BRASS LONG BODY BIB COCK**

The CP brass long body bib cock shall be conforming to IS standards. The body shall be of chromium plated copper alloy and external and internal surfaces shall be clean, smooth and free from sand. The 15mm nominal bore shall be designated by the nominal bore of the pipe outlet to which the long body bib cocks are normally fitted.

The weight of long body Bib Cock shall be less than 690 grams. Each bib cock shall be legibly marked with the Manufacture's name and trade mark.

### **18.26 CP BRASS STOP COCK (CONCEALED)**

The CP brass stop cock shall be conforming to IS : 8931. The body shall be of chromium plated copper alloy and external and internal surfaces shall be clean, smooth and free from sand. The 15mm nominal bore shall be designated by the nominal bore of the pipe outlet to which the stop cocks are normally fitted. The dimensions of body for stop Cock shall be as per table given to IS : 8931. Each stop cock shall be legibly marked with the Manufacture's name and trade mark.

### **18.27 CP BRASS ANGLE VALVE**

A valve with the inlet and outlet at right angles to each other and is intended to facilitate servicing of water fittings or appliances.

The CP brass angle valve shall be conforming to IS: 8931. The body shall be of chromium plated copper alloy and external and internal surfaces shall be clean, smooth and free from sand. The 15mm nominal bore shall be designated by the nominal bore of the pipe outlet to which the angle valves are normally fitted.

The dimensions of body for angle valve shall be as per table given to IS: 8931. Each angle valve shall be legibly marked with the Manufacture's name and trade mark.

#### **18.28 CP BRASS EXTENSION NIPPLE**

The body shall be of chromium plated copper alloy and external and internal surfaces shall be clean, smooth and free from sand. The size of CP brass extension nipple shall be 15mm x 50mm.

#### **18.29 PTMT BIB COCK**

The PTMT (Poly-tetra Methylene Terephthalate) bib cock shall be of appropriate size as specified and weight should not be less than as specified. External and internal surfaces shall be clean and smooth with good finish. Its colour shall be uniform. Each fitting shall be legibly marked with the manufacture's name and trade mark. Teflon tape shall be used on threads while fixing to make them leak proof.

#### **18.30 PTMT STOP COCK**

The PTMT (Poly-tetra Methylene Terephthalate) stop cock shall be of appropriate size as specified and weight should not be less than as specified. External and internal surfaces shall be clean and smooth with good finish. Its colour shall be uniform. Each fitting shall be legibly marked with the manufacture's name and trade mark. Teflon tape shall be used on threads while fixing to make them leak proof.

#### **18.31 PTMT PILLAR COCK**

The PTMT (Poly-tetra Methylene Terephthalate) pillar cock shall be of appropriate size as specified and weight should not be less than as specified. External and internal surfaces shall be clean and smooth with good finish. Its colour shall be uniform. Each fitting shall be legibly marked with the manufacture's name and trade mark. Teflon tape shall be used on threads while fixing to make them leak proof.

#### **18.32 PTMT PUSH COCK**

The PTMT (Poly-tetra Methylene Terephthalate) push cock shall be of appropriate size as specified and weight should not be less than as specified. External and internal surfaces shall be clean and smooth with good finish. Its colour shall be uniform. Each fitting shall be legibly marked with the manufacture's name and trade mark. Teflon tape shall be used on threads while fixing to make them leak proof.

#### **18.33 PTMT GRATING**

The PTMT (Poly-tetra Methylene Terephthalate) grating shall be of appropriate size as specified. External and internal surfaces shall be clean and smooth with good finish. Its colour shall be uniform. Each fitting shall be legibly marked with the manufacture's name and trade mark.

#### **18.34 PTMT BALL COCK**

The PTMT (Poly-tetra Methylene Terephthalate) ball cock shall be of appropriate size as specified and weight should not be less than as specified. External and internal surfaces shall be clean and smooth with good finish. Its colour shall be uniform. Each fitting shall be legibly marked with the manufacture's name and trade mark. Teflon tape shall be used on threads while fixing to make them leak proof.

#### **18.35 PTMT ANGLE STOP COCK**

The PTMT (Poly-tetra Methylene Terephthalate) angle stop cock shall be of appropriate size as specified and weight should not be less than as specified. External and internal surfaces shall be clean and smooth with good finish. Its colour shall be uniform. Each fitting shall be legibly marked with the manufacture's name and trade mark. Teflon tape shall be used on threads while fixing to make them leak proof.

#### **18.36 PVC CONNECTION PIPE**

The PVC connection pipe with PTMT nuts, collar and bush shall be conforming to IS: 1024. The standard size of PVC connection pipe shall be designated by the nominal bore with length. A sample of each kind of fitting shall be got approved from the Engineer-in-charge and supplies made according to the approved sample. PVC connection pipe shall be enumerated and rate shall include the cost of material and labour involved in fixing the same.

**18.37 PTMT EXTENSION NIPPLE FOR WATER TANK PIPE**

The standard size of PTMT extension Nipple for water tank pipe, fitting shall be designated by the nominal bore weighing not less than prescribed in the item. A sample of each kind of fitting shall be got approved from the Engineer-in-charge and supplies made according to the approved sample. PTMT extension Nipple for water tank pipe shall be enumerated and rate shall include the cost of material and labour involved in fixing the same.

**18.38 DISINFECTING C.I WATER MAINS BY FLUSHING WITH WATER**

Disinfecting C.I water mains of different diameter pipe by flushing with water containing bleaching powder @0.5 gms per litre of water and cleaning the same with fresh water, operation to be repeated three times including getting the sample of water from the disinfected main and shall be tested in the municipal laboratory and final sample obtained shall confirm to the standards.

**18.39 CHROME PLATED BRASS BATTERY BASED INFRARED SENSOR OPERATED PILLAR COCK**

The chrome plated brass battery based infrared sensor operated pillar cock shall be of chromium plated copper alloy and external and internal surface shall be clean, smooth and free from sand. The 15 mm nominal bore shall be designated by the nominal bore of the pipe outlet to which the chrome plated brass battery based infrared sensor operated pillar cock are normally fitted.

Each chrome plated brass battery based infrared sensor operated pillar cock shall be legibly marked with the manufacture's name and trade mark. Chrome plated brass battery based infrared sensor operated pillar cock shall be enumerated and rate shall include the cost of material and labour involved in fixing the same.

**TOLERANCES FOR CAST IRON (CENTRIFUGALLY CAST) PIPES**  
(Clause 18.3.10)

| <i>Dimensions</i>                    | <i>Nominal diameter (DN)</i>                    | <i>Tolerances in mm</i>                    |
|--------------------------------------|---|--|
| (a) External diameter of barrel (DE) | All diameters.                                  | $\pm 1/2f = \pm (4.5 + 0.0015 \text{ DN})$ |
| (b) Internal diameter of socket (DI) | All diameters.                                  | $\pm 1/3f = \pm (3 \pm 0.001 \text{ DN})$  |
| (c) Depth of socket (P)              | (1) Up to and including 600 mm                  | $\pm 5$                                    |
|                                      | (2) Over 600 mm and up to and including 1000 mm | $\pm 10$                                   |

**Note :** (1) *f* is the caulking space of the joint in millimeters and is equal to  $9 + 0.003 \text{ DN}$ .  
(2) The jointing tolerances applicable to rubber joints (mechanical or push in joints) shall be as specified by their manufacturer and shall be within the tolerances specified above.

**Tolerance on Thickness**

| <i>Dimensions</i>    | <i>Tolerance in mm</i> |
|----------------------|------------------------|
| (a) Wall thickness   | $-(1 + 0.05 e)$        |
| (b) Flange thickness | $\pm (2 + 0.05 b)$     |

Where *e* = is the thickness of the wall in millimeters and  
*b* = is the thickness of the flange in millimeters.

**Tolerance on Length**

| <i>Dimensions</i>                            | <i>Tolerance in mm</i> |
|--|------------------------|
| (a) Socket and spigot, and plain ended pipes | $\pm 25$               |
| (b) Flanged pipes                            | $\pm 10$               |

**TOLERANCES FOR SPECIALS OF CAST IRON PIPES**  
(Clause 18.3.10.2)

**Tolerances in Diameter**

| Dimension  | Nature of joint | Nominal diameter (DN)                     | Tolerance in mm |
|--|-----------------|---|-----------------|
| External diameter of spigot (DE)<br>f or $\pm (4.5 + 0.0015 \text{ DN})$ | Lead joints     | All diameters                             | $\pm 1/2$       |
| Internal diameter of socket (DI)<br>f or $\pm (3 + 0.001 \text{ DN})$    | Lead joints     | All diameters                             | $\pm 1/3$       |
| Depth of socket (P)  | Lead joints     | Up to and including 600 mm                | $\pm 5$         |
|  |                 | Over 600 mm up to and including 1000 mm.  | $\pm 10$        |
|  |                 | Over 1000 mm up to and including 1500 mm. | $\pm 15$        |

**Tolerances on Thickness**

| Dimension        | Tolerance in mm    |
|------------------|--------------------|
| Wall thickness   | $-(2 + 0.05 e)$    |
| Flange thickness | $\pm (3 + 0.05 b)$ |

Where  $e$  = the standard thickness of the wall in millimeters, and  
 $b$  = the standard thickness of the flange in millimeters.

**Tolerance on Lengths**

| <i>Type of fitting</i>                   | <i>Nominal diameter</i>    | <i>Tolerance in mm</i> |
|--|----------------------------|------------------------|
| Socket fittings and flange spigot pieces | Up to and including 450 mm | $\pm 20$               |
|  | Over 450 mm                | $\pm 20 - 30$          |
| Flanged fittings                         | All diameters              | $\pm 10$               |

**PARTICULARS OF MEDIUM GRADE G.I. PIPES**  
(Clause 18.3.11.3)

| Nominal bore<br>(mm) | Dimension of pipes |             |                   | Weight of pipe      |                                 |
|----------------------|--------------------|-------------|-------------------|---------------------|---------------------------------|
|                      | Outer diameter     |             | Thickness<br>(mm) | Plain end<br>(kg/m) | Screwed end<br>socket<br>(kg/m) |
|                      | Max<br>(mm)        | Min<br>(mm) |                   |                     |                                 |
| 6                    | 10.6               | 9.8         | 2.0               | 0.404               | 0.407                           |
| 8                    | 14.0               | 13.2        | 2.3               | 0.641               | 0.645                           |
| 10                   | 17.5               | 16.7        | 2.3               | 0.839               | 0.845                           |
| 15                   | 21.8               | 21.0        | 2.6               | 1.21                | 1.22                            |
| 20                   | 27.3               | 26.5        | 2.6               | 1.56                | 1.57                            |
| 25                   | 34.2               | 33.3        | 3.2               | 2.41                | 2.43                            |
| 32                   | 42.9               | 42.0        | 3.2               | 3.10                | 3.13                            |
| 40                   | 48.8               | 47.9        | 3.2               | 3.56                | 3.60                            |
| 50                   | 60.8               | 59.7        | 3.6               | 5.03                | 5.10                            |
| 65                   | 76.6               | 75.3        | 3.6               | 6.42                | 6.54                            |
| 80                   | 89.5               | 88.0        | 4.0               | 8.36                | 8.53                            |
| 100                  | 115.0              | 113.1       | 4.5               | 12.2                | 12.50                           |
| 125                  | 140.8              | 138.5       | 4.8               | 15.90               | 16.40                           |
| 150                  | 166.5              | 163.9       | 4.8               | 18.90               | 19.50                           |

**Tolerance in Thickness and Weight****A) Thickness**

- |                             |                                  |
|-----------------------------|----------------------------------|
| 1. Butt welded medium tubes | + not limited<br>- 10 per cent   |
| 2. Seamless tubes           | + not limited<br>- 12.5 per cent |

**B) Weight**

- |  |                               |
|--|-------------------------------|
| 1. Single tube (light series)  | + 10 per cent<br>- 8 per cent |
| 2. Single tube (medium and heavy series)                               | ± 10 per cent                 |
| 3. For quantities per load of 10 tonnes, min (light series)            | ± 5 per cent<br>- 8 per cent  |
| 4. For quantities per load of 10 tonnes, min (medium and heavy series) | ± 7.5 per cent                |



## PROCEDURE FOR PRESSURE TEST (Clause 18.5.6)

1. Each valved section of the pipe shall be slowly filled with water and all air shall be expelled from the pipe through hydrants and blow-offs. If these are not available at high places, necessary tapping may be made at points of highest elevation before the test is made and plugs inserted after the tests have been completed.

2. If the trench has been partially back-filled the specified pressure based on the elevation of the lowest point of the line or section under test and corrected to the elevation of the test gauge, shall be applied by means of a pump connected to the pipe in a manner satisfactory to the Engineer-in-Charge. The duration of the test shall not be less than 5 minutes.

**3. Examination under Pressure:** All exposed pipes, fittings, valves, hydrants and joints should be carefully examined during the open-trench test. When the joints are made with lead, all such joints showing visible leaks shall be recaulked until tight. When the joints are made with cement and show seepage or slight leakage, such joints shall be cut out and replaced as directed by the authority. Any cracked or defective pipes, fittings, valves or hydrants discovered in consequence of this pressure test shall be removed and replaced by sound material and the test shall be repeated until satisfactory to the Engineer-in-Charge.

4. If the trench has been back-filled to the top, the section shall be first subjected to water pressure normal to the area and the exposed parts shall be carefully examined. If any defects are found, they shall be repaired and the pressure test repeated until no defects are found. The duration of the final pressure tests shall be at least one hour.

### Procedure for Leakage Test

5. Leakage is defined as the quantity of water to be supplied into the newly laid pipe, or any valved section thereof, necessary to maintain the specified leakage test pressure after the pipe has been filled with water and the air expelled.

No pipe installation shall be accepted until the leakage is less than the number of  $\text{cm}^3/\text{h}$  determined by the formula:

$$ql = \frac{ND\sqrt{P}}{3.3}$$

Where ql = the allowable leakage in  $\text{cm}^3/\text{h}$ .  
 N = number of joints in the length of the pipe line.  
 D = diameter in mm, and  
 P = the average test pressure during the leakage testing  $\text{kg}/\text{cm}^2$ .

**6. Variation from Permissible Leakage:** Should any test of pipe laid in position discloses leakage greater than that specified in Para 5 the defective joints shall be repaired until the leakage is within the specified allowance.

## GUIDELINES FOR STORAGE AND INSTALLATION OF CPVC PIPES

### E-1 STORAGE

CPVC pipes of all sizes are packed in polyethylene packing rolls and both the ends of the packed roll are sealed with air bubble film cap in order to provide protection during handling and transportation. After packing, the whole bunch of pipes is tightened with polypropylene/ HDPE strapping. Each roll is then marked with size/type of the pipe, lot number and quantity. The packed pipe rolls are stored in their respective racks in properly covered storage area. Apart from providing protection during handling and transportation, the packing rolls also protect the pipe from ultra violet rays.

### E-2 INSTALLATION GUIDELINES

**E-2.1** Visually inspect pipe ends before making the joint. Use of a chamfering tool will help identify and crakes, as it will catch on to any crack.

**E-2.2** Pipe may be cut quickly and efficiently by several methods. Wheel type plastic tubing cutters are preferred. Ratchet type cutter or fine tooth saw are another options. However, when using the ratchet cutter be certain to score the exterior wall by rotating the cutter blade in circular motion around the pipe. Do this before applying significant downward pressure to finalize the cut. This step leads to a square cut. In addition, make sure ratchet cutter blades are sharp. Cutting tubing as squarely as possible provides optimal bonding area within a joint.

**E-2.3** Burrs and filings can prevent proper contact between the tube and fittings during the assembly, and should be removed from the outside and inside of the tube. A chamfering tool is preferred, but a pocket knife or file is also suitable for this purpose.

**E-2.4** Use only CPVC cement jointing. Use CPVC cement, which is fully recommended by the manufacturer.

**E-2.5** When using adhesive solution/solvent cement be certain of proper ventilation.

**E-2.6** When making a join, apply a heavy, even coat of cement to the pipe end. Use the same applicator without additional cement to apply a thin coat inside the fitting socket. Too much cement can cause clogged waterways. Do not allow excess cement to puddle in the fitting and pipe assembly. This could result in a weakening of the pipe wall and possible pipe failure when the system is pressurized.

**E-2.7** Rotate pipe one-quarter to one-half turn while inserting it into the fitting socket and remove the excess adhesive solution/solvent cement from the joint with clean rag.

**E-2.8** When making a transition connection to metal threads, use a special transition fitting or CPVC male threaded adapter whenever possible. Do not over-torque plastic threaded connections. Hand tight plus one-half turn should be adequate.

**E-2.9** Hang or strap CPVC systems loosely to allow for thermal expansion. Do not use metal straps with sharp edges that might damage the tubing.

**E- 2.10** CPVC stub outs for lavatories, closets and sinks are appropriate. However, on areas where there is a likelihood that movement or impact abuse will occur, metal pipe nipples may be amore appropriate stub-out material. Showerheads, tub spouts and outside still cocks are examples.

**E-2.11** When connected to a gas water heater, CPVC tubing should not be located within 50 cm of the flue. For water heaters lacking reliable temperature control, this distance may be increased up to 1 m a metal nipple or flexible appliance connector should be utilized. This measure eliminates the potential for damage to plastic piping that might result from excessive radiant heat from the flue.

## SAMPLING AND CRITERIA FOR CONFORMITY OF CPVC PIPES (Clause 18.9.6)

### F-1 ACCEPTANCE TESTS

**F-1.1** Acceptance test are carried out on samples selected from a lot for the purpose of acceptance of the lot.

#### F-1.2 Lot

All CPVC pipes in a single consignment of the same class, same size and manufactured under essentially similar conditions shall constitute a lot.

**F-1.3** For ascertaining conformity of the lot to the requirements of the specification, samples shall be tested from each lot separately.

#### F-1.4 Visual and Dimensional Requirements

**F-1.4.1** The number of test samples to be taken from a lot shall depend on the size of the lot and the outside diameter of the pipe, and shall be in accordance with Table F-1.

**TABLE F-1**  
**Scale of Sampling of Visual Appearance and Dimensional Requirements**  
(Clause F-1.4.1 and F-1.4.3)

| Sl. No. | Number of pipes in the lot | Sample number | Sample size | Cumulative sample size | Acceptance number | Rejection number |
|---------|----------------------------|---------------|-------------|------------------------|-------------------|------------------|
| (1)     | (2)                        | (3)           | (4)         | (5)                    | (6)               | (7)              |
| (i)     | Up to 1000                 | First         | 13          | 13                     | 0                 | 2                |
|         |                            | Second        | 13          | 26                     | 1                 | 2                |
| (ii)    | 1001 to 3000               | First         | 20          | 20                     | 0                 | 2                |
|         |                            | Second        | 20          | 40                     | 1                 | 2                |
| (iii)   | 3001 to 10000              | First         | 32          | 32                     | 0                 | 3                |
|         |                            | Second        | 32          | 64                     | 3                 | 4                |
| (iv)    | 10001 & above              | First         | 50          | 50                     | 1                 | 4                |
|         |                            | Second        | 50          | 100                    | 4                 | 5                |

**F-1.4.2** These pipes shall be selected at random from the lot and in order to ensure the randomness of selection, a random number table shall be used. For guidance and use of random number tables, IS-4905 may be referred to. In the absence of a random number table, the following procedure may be adopted:

Starting from any pipe in the lot, count them as 1, 2, 3, etc, up to r and so on, where r is the integral part of  $N/n$ , N being the number of pipes in the lot, and n the number of pipes in the sample. Every rth pipe so counted shall be withdrawn so as to constitute the requires sample size.

**F-1.4.3** The number of pipes given for the first sample in col. 4 of Table F-1, shall be taken from the lot and examined for visual and dimensional requirements given in Table 18.16 and 18.9.4.1. A pipe failing to satisfy any of these requirements shall be considered as defective. The lot shall be deemed to have satisfied these requirements, if the number of defectives found in the firm sample is less than or equal to the corresponding acceptance number given in col. 6 of Table F-1. The lot shall be deemed not to have met these requirements, if the number of defectives found in the first sample is greater than or equal to the corresponding rejection number given in col. 7 of Table F-1. If, however, the number of defectives found in the first sample lies between the corresponding acceptance and rejection numbers given in cols. 6 and 7, a second sample of the size given in col. 4 shall be taken

and examined for the requirements. The lot shall be considered to have satisfied these requirements. The lot shall be considered to have satisfied these requirements if the cumulative sample is less than or equal to the corresponding acceptance number given in col. 6, otherwise not.

**F-1.5 Reversion Test**

**F-1.5.1** The lot, having satisfied visual and dimensional requirements, shall be tested for reversion as given in 18.9.4.4.

**F-1.5.2** For this purpose, the number of pipes given for the first sample in col. 4 of Table F-2 shall be taken from the lot. The sample pipe failing the reversion test shall be considered as defective. The lot shall be deemed to have met the requirements given in this specification for the reversion test, if the number of defectives found in the first sample is less than or equal to the corresponding acceptance number given in col. 6. This lot shall be deemed not to have met these requirements, if the number of defectives found in the first sample is greater than or equal to the corresponding rejection number given in col. 7 if, however, the number of defectives in the first sample lies between the corresponding acceptance and rejection numbers given in col. 6 and col. 7, a second sample of size given in col. 4 shall be taken and examined for the requirements. The lot shall be considered to have satisfied the requirements, if the number of defectives found in the cumulative sample is less than or equal to the corresponding acceptance number given in col. 6, otherwise not.

**TABLE F-2**  
**Scale of Sampling for Reversion, Vicat Softening Temperature and Density Test**  
*(Clause F-1.5.2, F-1.6.2 and F-1.7.2)*

| Sl. No. | Number of pipes in the lot | Sample number | Sample size | Cumulative sample size | Acceptance number | Rejection number |
|---------|----------------------------|---------------|-------------|------------------------|-------------------|------------------|
| (1)     | (2)                        | (3)           | (4)         | (5)                    | (6)               | (7)              |
| (i)     | Up to 1000                 | First         | 5           | 5                      | 0                 | 2                |
|         |                            | Second        | 5           | 10                     | 1                 | 2                |
| (ii)    | 1001 to 3000               | First         | 8           | 8                      | 0                 | 2                |
|         |                            | Second        | 8           | 16                     | 1                 | 2                |
| (iii)   | 3001 to 10000              | First         | 13          | 13                     | 0                 | 2                |
|         |                            | Second        | 13          | 26                     | 1                 | 2                |
| (iv)    | 10001 & above              | First         | 20          | 20                     | 0                 | 3                |
|         |                            | Second        | 20          | 40                     | 3                 | 4                |

**F-1.6 Vicat Softening Test**

**F-1.6.1** The lot, having satisfied visual and dimensional requirements shall be tested for Vicat softening temperature as given in 18.9.4.5.

**F-1.6.2** For this purpose, the procedure adopted for sampling and criteria for conformity shall be the same as that for reversion under F-1.5.2 using Table F-2.

**F-1.7 Density**

**F-1.7.1** The lot, having satisfied the visual and dimensional requirements, shall be tested for density as given in 18.9.4.6.

**F-1.7.2** For this purpose, the procedure adopted for sampling and criteria for conformity shall be the same as that for reversion under F-1.5.2 using Table F-2.

**F-1.8 Resistance to External Blow at 0°C**

**F-1.8.1** The lot, having been found satisfactory according to F-1.4, F-1.5, F-1.6 and F-1.7 shall be tested for resistance to external blow at 0°C as given in 18.9.5.3.

**F-1.8.2** For this purpose, the procedure adopted for sampling and criteria for conformity shall be as specified in Table 18.18 and Table F-3.

**TABLE F-3**  
**Scale of Sampling for Resistance to External Blow at 0°C**

| Sl. No. | Number of pipes in the lot | Sample number | Sample size | Cumulative sample size | Acceptance number | Rejection number |
|---------|----------------------------|---------------|-------------|------------------------|-------------------|------------------|
| (1)     | (2)                        | (3)           | (4)         | (5)                    | (6)               | (7)              |
| (i)     | Up to 3000                 | First         | 3           | 3                      | 0                 | 2                |
|         |                            | Second        | 3           | 6                      | 1                 | 2                |
| (ii)    | 3001 to 10000              | First         | 3           | 5                      | 0                 | 2                |
|         |                            | Second        | 5           | 10                     | 1                 | 2                |
| (iii)   | 10000 & above              | First         | 8           | 8                      | 0                 | 2                |
|         |                            | Second        | 8           | 10                     | 1                 | 2                |

**F-1.9 Internal Hydrostatic Pressure Test (Acceptance Test)** **F-1.9.1** The lot having been found satisfactory according to F-1.4, F-1.5, F-1.6, F-1.7 and F-1.8 shall be subjected to the requirements of the acceptance test for internal hydrostatic pressure as given in 18.9.5.1 and Table 18.17 Sl.No. (i). The number of pipes to be taken from the lot shall depend on the size of the lot and shall be according to Table F-4.

**TABLE F-4**  
**Scale of Sampling for Internal Hydrostatic Test**  
**(Clause F-1.9.1 and F-1.9.3)**

| Sl. No. | Number of pipes in the lot | Sample size | Acceptance number |
|---------|----------------------------|-------------|-------------------|
| (1)     | (2)                        | (3)         | (4)               |
| (i)     | Up to 3000                 | 2           | 0                 |
| (ii)    | 3001 to 10000              | 3           | 0                 |
| (iii)   | 10000 & above              | 5           | 0                 |

**F-1.9.2** The pipes shall be taken at random from the lot. In order to ensure the randomness of selection, procedures given in IS 4905 may be followed.

**F-1.9.3 Number of Tests and Criteria for Conformity**

The number of test samples shall be as given in Table F-4. The lot shall be considered to have satisfied the requirements for this test, if the number of test samples failing in this requirement is equal to the corresponding acceptance number given in column 4 of Table F-4.

**F-2 TYPE TESTS**

**F-2.1** Type tests are intended to prove the suitability and performance of a new composition or a new size of pipe. Such tests, therefore, need to be applied only when a change is made in polymer composition or when a new size of pipe is to be introduced. Type test for compliance with 18.9.4.2, 18.9.4.3, 18.9.5.1 (Type test only) and 18.9.5.4 shall be carried out.

**F-2.1.1 Verification of Malfunction Temperature  $T_{mal}$**

For this test, the manufacturer to the testing authority one assembly, selected preferably from a regular production lot.

**F-2.1.2 Opacity**

For this test, the manufacturer or the supplier shall furnish to the testing authority one sample of the pipe of the thinnest wall section, selected preferably from a regular production lot.

**F- 2.1.2.1** The sample so selected shall be tested for compliance with requirements for opacity as given in 18.9.4.2.

**F-2.1.2.2** If the sample passes the requirements of the opacity test, the type of the pipe under consideration shall be considered to be eligible for approval, which shall be valid for a period of one year.

**F-2.1.2.3** In case the sample fails in the test, the testing authority, at its discretion, may call for a fresh sample and subject the same to the opacity test. If the sample passes the repeat test, the type of pipe under consideration shall be considered eligible for approval. If the sample fails in the repeat test, the type of pipe shall not be approved. The manufacturer or the supplier may be asked to improve the design and re-submit the product for type approval.

**F-2.1.2.4** At the end of the validity period (normally one year) or earlier, if necessary, the testing authority may call for a fresh sample for opacity test for the purpose of type approval.

**F-2.1.3 *Test for Effect on Water***

For this type test, the manufacturer or the supplier shall furnish to the testing authority three samples of the smallest size of pipe taken from each machine (selected preferably from a regular production lot).

**F-2.1.3.1** Three samples so selected shall be tested for compliance with the requirements for effect on water as given in 18.9.4.3.

**F-2.1.3.2** If all three samples pass the requirements for effect on water, the type test of the pipe under consideration shall be considered to be eligible for approval, which shall be normally valid for a period of one year.

**F-2.1.3.3** In case any of the samples fails in this test, the testing authority, at its discretion, may call for fresh samples not exceeding the original number, and subject them to the test for effect on water. If, in the repeat test, no single failure occurs, the type of pipe under consideration shall be considered eligible for type approval. If any of the samples fails in the repeat test, the type of pipe shall not be approved. The manufacturer or the supplier may be asked to improve the design and resubmit the product for type approval.

**F-2.1.3.4** At the end of the validity period (normally one year) or earlier, if necessary, the testing authority may call for fresh samples for effect on water test for the purpose of type approval.

**F-2.1.4 *Internal Hydrostatic Pressure Test (Type Test) and thermal Stability***

For this type test, the manufacturer or the supplier shall furnish to the testing authority, three samples of pipes of different diameters and different classes (selected preferably from a regular production lot).

**F-2.1.4.1** Three samples so selected shall be tested for compliance with the requirements of type test given in Table 18.9.4.3.

**F-2.1.4.2** If all the three samples pass the requirements of the quality test, the type of pipe under consideration shall be considered to be eligible for type approval which shall be normally valid for a period of one year.

**F-2.1.4.3** In case any of the samples fail in this test, the testing authority, at its discretion, may call for fresh samples not exceeding the original number and subject them to the type test. If, in the repeat test, no single failure occurs, the type of pipe shall be considered for type approval. If any of the samples fails in the repeat tests, the type of pipe shall not be approved. The manufacturer or the supplier may be asked to improve the design and resubmit the product for type approval.

**F-2.1.4.4** At the end of the validity period (normally one year) or earlier, if necessary, the testing authority may call for fresh samples for type test for the purpose of type approval.

**F-2.1.5 Tensile Strength Test (Type Test)**

For this type test, the manufacturer or the supplier shall furnish to the testing authority, five samples of pipe of different diameters and different class (selected preferably from a regular production lot).

**F-2.1.5.1** Five samples so selected shall be tested for compliance with the requirements of type test given in 18.9.5.4.

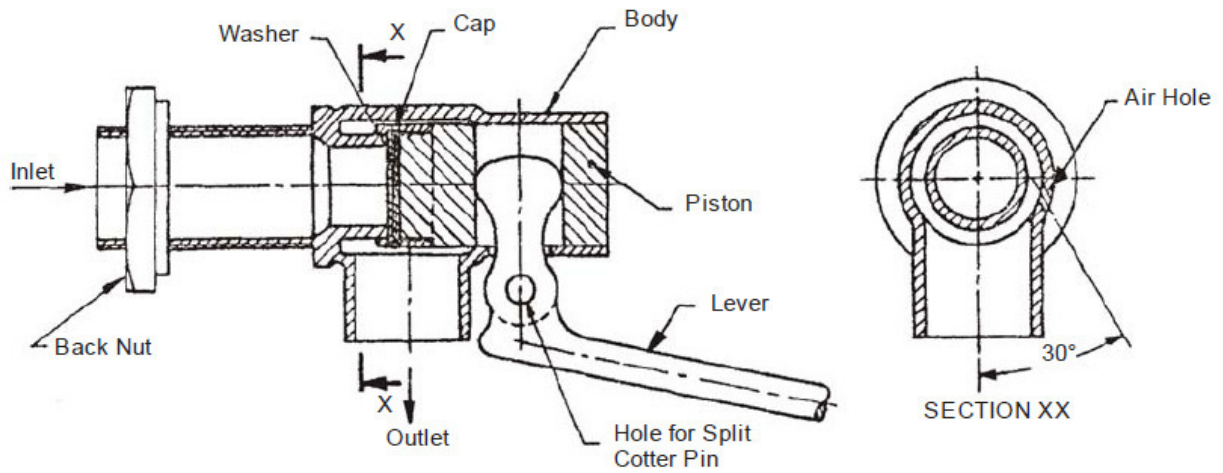
**F-2.1.5.2** If all the five samples pass the requirement of the quality test, the type test of pipe under consideration shall be considered to be eligible for type approval which shall be normally valid for a period of one year.

**F-2.1.5.3** In case any of the samples fails in this test, the testing authority, at its discretion, may call for fresh samples not exceeding the original numbers and subject them to the type test. If, in the repeat test no single failure occurs, the type of pipe shall be considered for type approval. If any of the samples fail in the repeat tests, the type of pipe shall not be approved. The manufacturer or the supplier may be asked to improve the design and resubmit the product for type approval.

**F-2.1.5.4** At the end of the validity period (normally one year) or earlier, if necessary, the testing authority may call for fresh samples for type test for the purpose of type approval.

## BALL VALVE (ASSEMBLY)

Sub Head : Water Supply  
Clause : 18.3.1



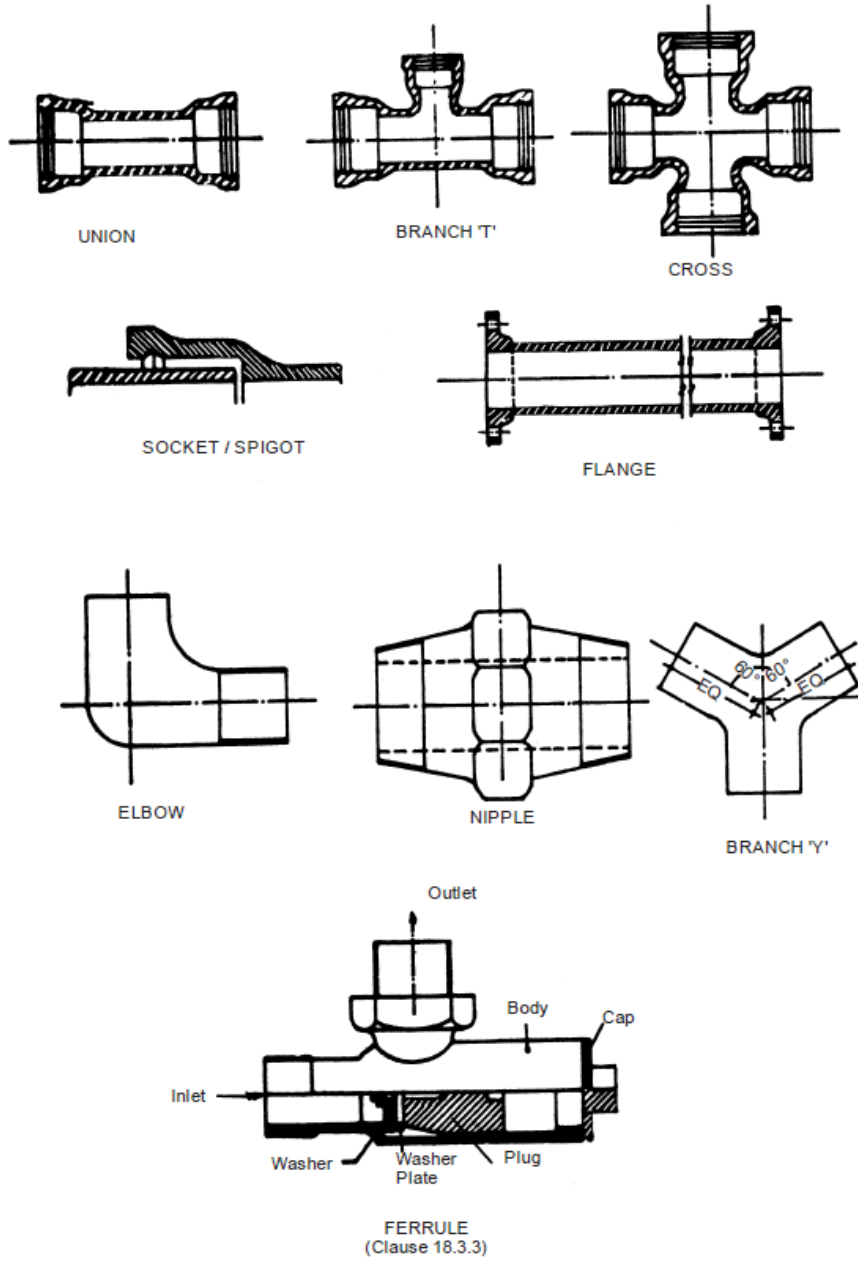
**Note :** The shapes of the component parts are only illustrative but the dimensions and minimum requirements, where specified, are binding.

**Fig. 18.1 : Ball Valve (Assembly)**



# FITTINGS & SPECIALS

Sub Head : Water Supply  
Clause : 18.3.9

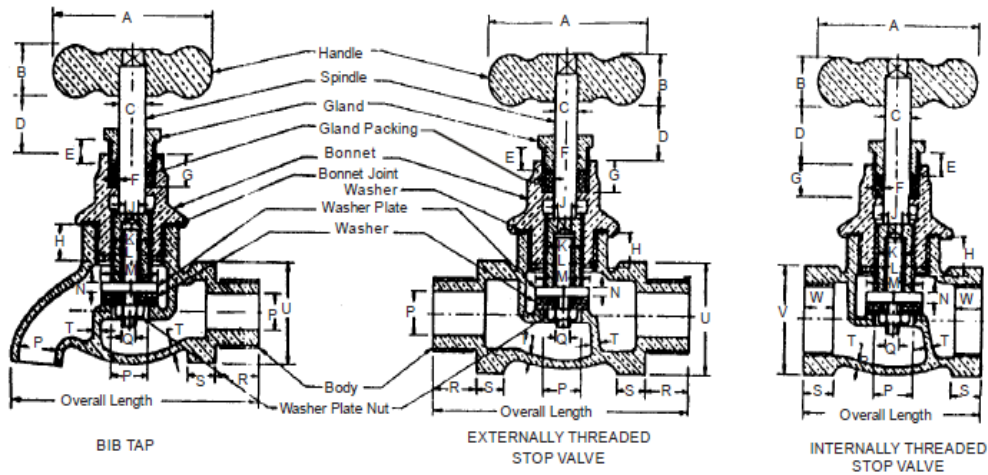


Drawing not to Scale

Fig. 18.2 : Fittings & Specials

# BIB TAP & STOP VALVE

Sub Head : Water Supply  
 Clause : 18.3.2



All dimensions in millimetres

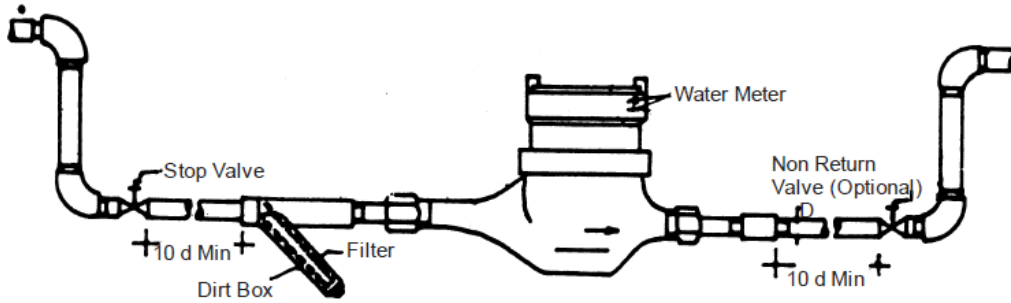
| Dimensions    | A    | B    | C    | D    | E    | F    | G    | H    | J    | K    | L       | M    | N    | P            | Q    | R    | S    | T    | U    | V    | W    | Lift of washer plate (with washer in position) |
|---------------|------|------|------|------|------|------|------|------|------|------|---------|------|------|--------------|------|------|------|------|------|------|------|--|
|               |      |      |      |      |      |      |      |      |      |      |         |      |      | +0.0<br>-0.5 |      |      |      |      |      |      |      | Min.   |
| Nominal sizes | Min. | Min. | Min. | Min. | Min. | Min. | Min. | Min. | Min. | Min. | Min.    | Min. | Min. | Min.         | Min. | Min. | Min. | Min. | Min. | Min. | Min. | Min.   |
| 8             | 47.8 | 13.3 | 7.8  | 16.5 | 6.3  | 2.0  | 7.9  | 7.0  | 3.8  | 10.0 | M20x1.5 | 14.3 | 2.8  | 6.5          | 2.4  | 11.0 | 4.7  | 1.6  | 15.2 | 19.5 | 7    | 3.5  |
| 10            | 54.0 | 14.0 | 9.4  | 18.7 | 7.5  | 2.0  | 9.5  | 9.5  | 4.7  | 11.5 | M20x1.5 | 15.9 | 3.2  | 9.0          | 3.2  | 11.4 | 7.9  | 2.0  | 20.8 | 23.3 | 7    | 4  |
| 15            | 54.0 | 14.0 | 9.4  | 19.0 | 7.5  | 2.0  | 9.5  | 11.0 | 5.6  | 11.5 | M24 1.5 | 19.0 | 3.2  | 13.0         | 4.1  | 15.0 | 9.5  | 2.0  | 25.6 | 28.3 | 9    | 4.5  |
| 20            | 60.4 | 15.7 | 10.9 | 20.1 | 8.9  | 2.5  | 11.1 | 12.5 | 6.4  | 13.5 | M30x1.5 | 25.4 | 4.0  | 18.0         | 4.9  | 16.3 | 10.3 | 2.0  | 30.5 | 33.0 | 10.5 | 6  |
| 25            | 66.8 | 18.0 | 12.5 | 23.0 | 10.1 | 2.5  | 12.7 | 13.0 | 7.1  | 17.0 | M39x1.5 | 33.3 | 4.0  | 23.0         | 4.9  | 19.1 | 11.0 | 2.8  | 37.6 | 42.4 | 11.5 | 7  |
| 32            | 74.6 | 20.5 | 14.1 | 30.9 | 11.4 | 2.5  | 14.3 | 16.0 | 7.8  | 19.0 | M48x1.5 | 40.1 | 4.3  | 30           | 5.9  | 21.4 | 12.7 | 3.2  | 47.2 | 52.1 | 13.5 | 9.5  |
| 40            | 82.5 | 22.0 | 15.7 | 33.3 | 12.7 | 2.5  | 15.9 | 17.5 | 8.6  | 20.5 | M56x1.5 | 47.7 | 5.5  | 36           | 6.6  | 21.4 | 14.3 | 3.2  | 56.4 | 58.5 | 13.5 | 11   |
| 50            | 95.0 | 25.3 | 17.3 | 35.9 | 14.0 | 2.5  | 17.4 | 17.5 | 12.5 | 26.0 | M72x1.5 | 63.5 | 6.3  | 46           | 8.3  | 25.1 | 15.9 | 4.0  | 70.1 | 71.5 | 16.5 | 14.5   |

- Note 1 : Length of thread R includes cut back under hexagon, if any.
- Note 2 : The values of K are for core diameter.
- Note 3 : The diameter of U and V are for face to face.
- Note 4 : The dimension F is packing space.

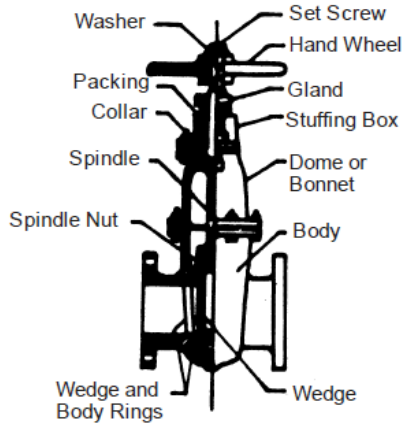
Fig. 18.3 : Bib Tap & Stop Valve

# COCKS VALVES & METER

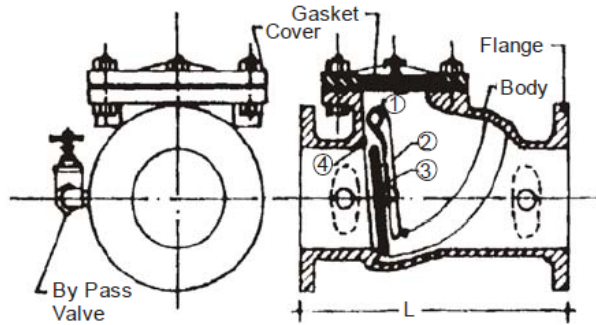
Sub Head : Water Supply  
 Clause : 18.3.15



## WATER METER ASSEMBLY



**SLUICE VALVE**  
 (Clause 18.3.13)



**NON-RETURN VALVE**  
 (Clause 18.3.8)

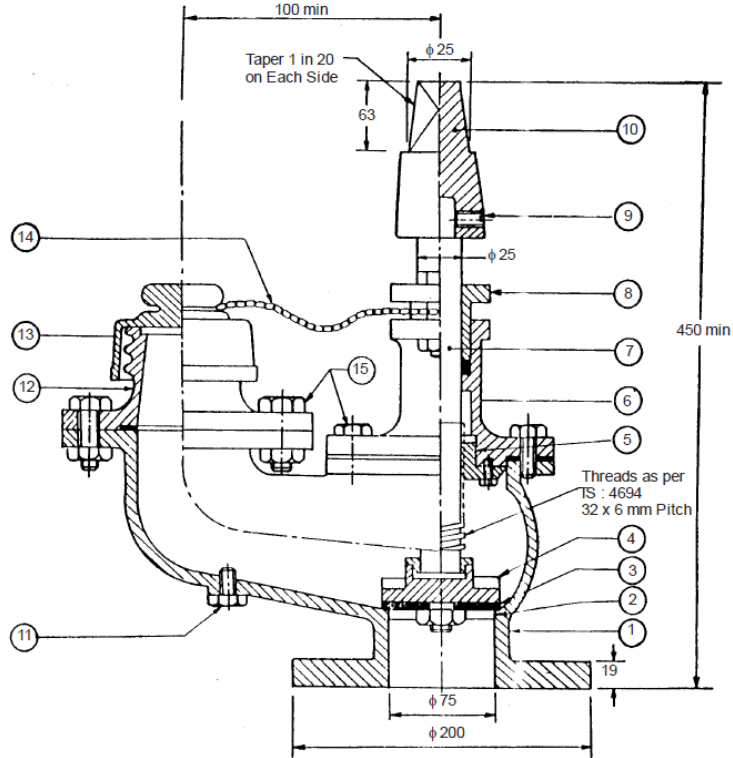
- ① Hinge Pin
- ② Hinge
- ③ Door
- ④ Body Ring

Drawing not to Scale  
 All Dimensions are in MM

**Fig. 18.4 : Cocks Valves & Meter**

# UNDERGROUND FIRE HYDRANT, SLUICE-VALVE GATE

Sub Head : Water Supply  
 Clause : 18.3.4



| No | Description        | Mat.    | Mat. Specification |
|----|--------------------|---------|--------------------|
| 1  | Body               | C.I.    | IS 210-1972 FG-200 |
| 2  | Valve Seat         | G.M.    | IS 318-1981 LTB-2  |
| 3  | Washer             | Rubber  | IS 937-1981        |
| 4  | Valve              | G.M.    | IS 318-1981 LTB-2  |
| 5  | Spindle Nut        | G.M.    | IS 318-1981 LBT-2  |
| 6  | Bonnet             | C.I.    | IS 210-1978 FG-200 |
| 7  | Spindle            | Brass   | IS 319-1989        |
| 8  | Gland              | C.I.    | IS 210-1978 FG-200 |
| 9  | Grub Screw (12 mm) | M.S.    | IS 6094-1981       |
| 10 | Spindle Cap        | C.I.    | IS 210-1978 FG-200 |
| 11 | Drain Bolt         | M.S.    | -                  |
| 12 | Outlet             | G.M.    | IS 318-1981 LTB-2  |
| 13 | Cap                | C.I.    | IS 210-1978 FG-200 |
| 14 | Chain              | Gal. MS | -                  |
| 15 | Nut and Bolt       | M.S.    | -                  |

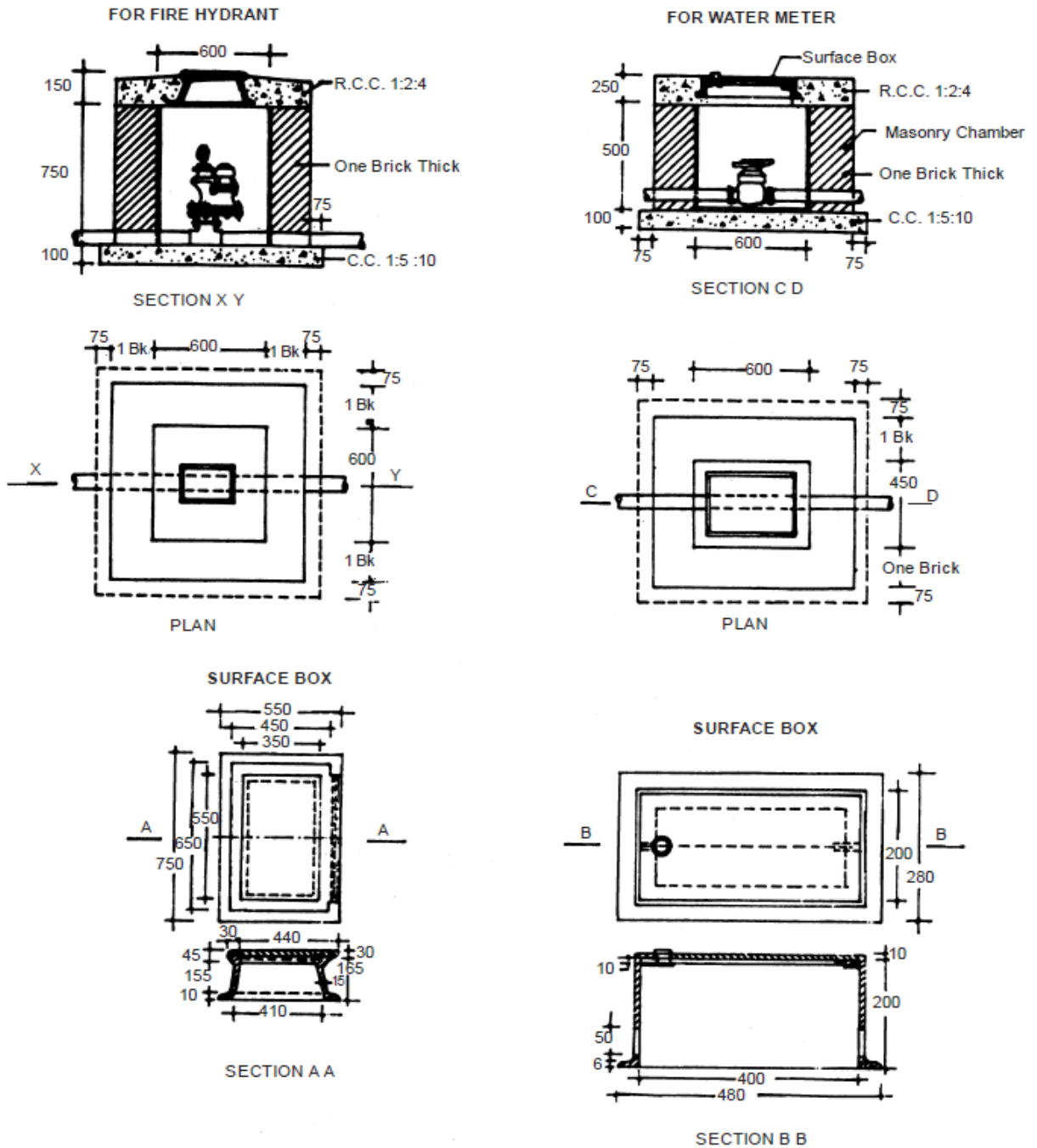
TOLERANCES AS PER IS 2102-1962

All Dimensions are in MM

**Fig. 18.5 : Underground Fire Hydrant, Sluice-Valve Gate**

# MASONRY CHAMBERS & SURFACE BOXES

Sub Head : Water Supply  
 Clause : 18.3.14

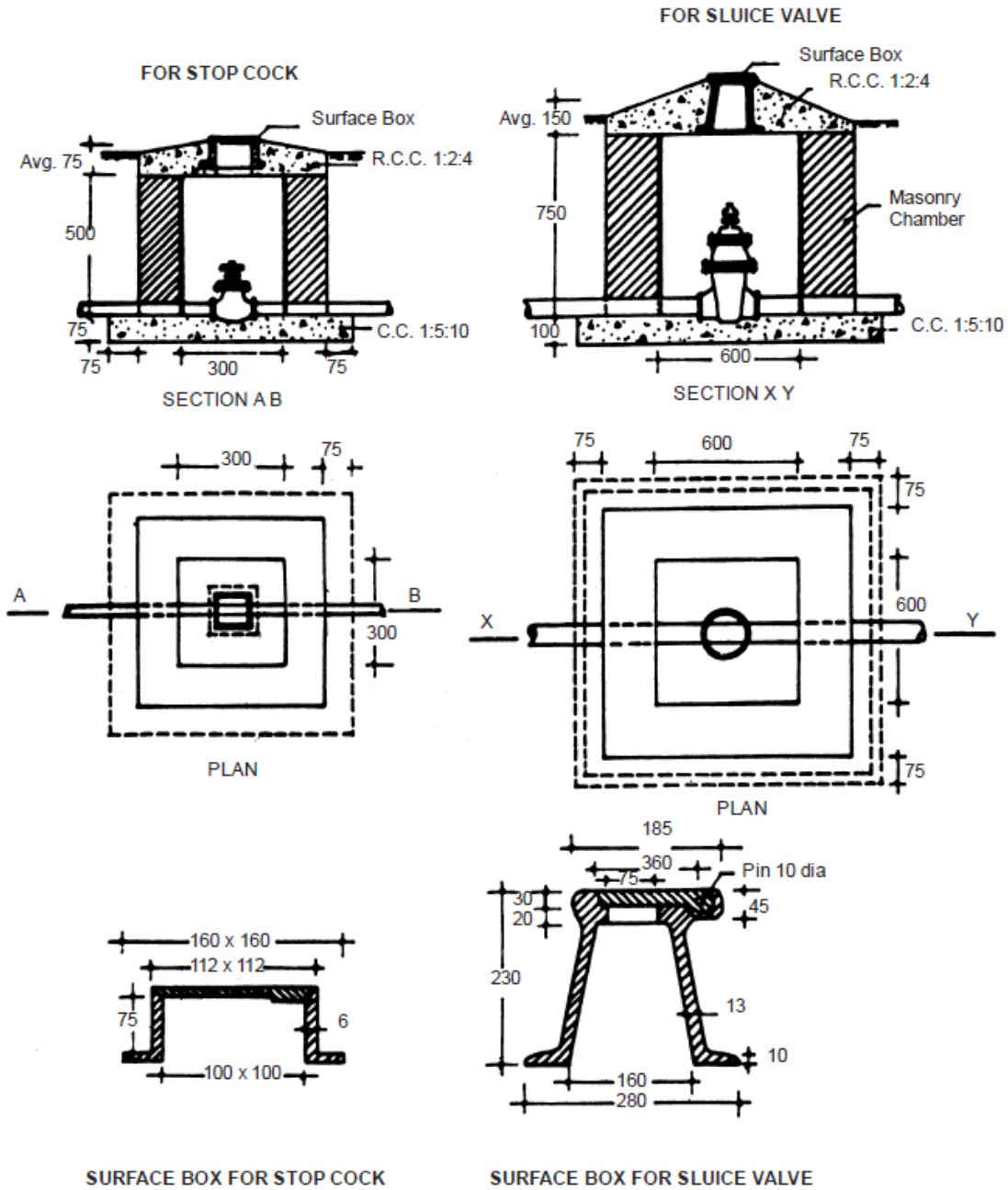


Drawing not to Scale  
 All Dimensions are in MM

Fig. 18.6 : Masonry Chambers & Surface Boxes

## MASONRY CHAMBERS & SURFACE BOXES (Contd.)

Sub Head : Water Supply  
Clause : 18.3.14

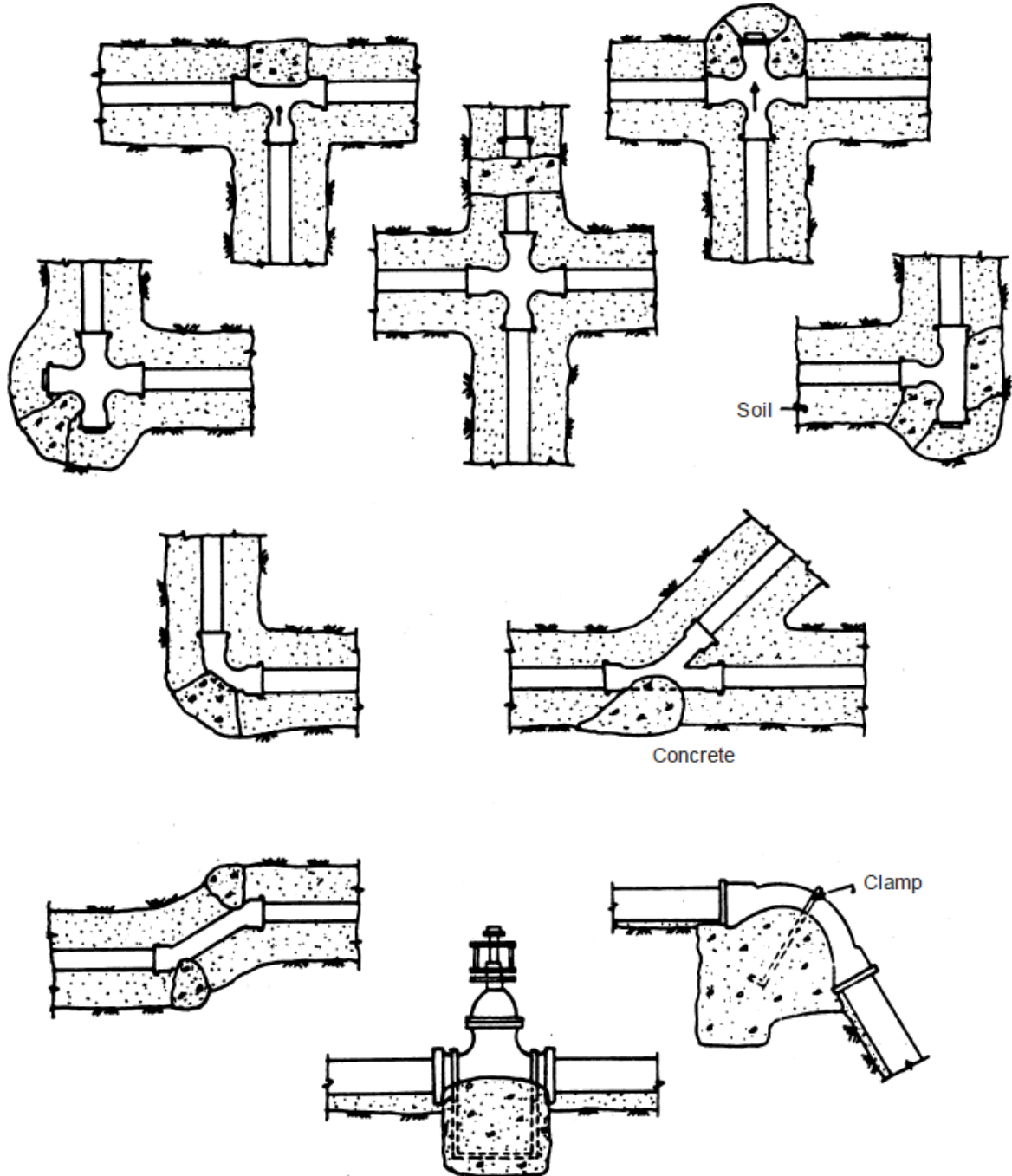


Drawing not to Scale  
All Dimensions are in MM

Fig. 18.7 : Masonry Chambers & Surface Boxes (Contd.)

# THRUST BLOCKS

Sub Head : Water Supply  
Clause : 18.4.6

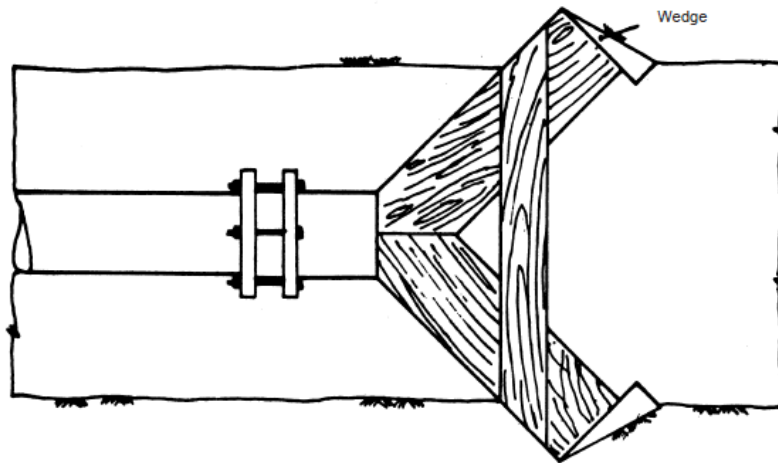


Drawing Not to Scale

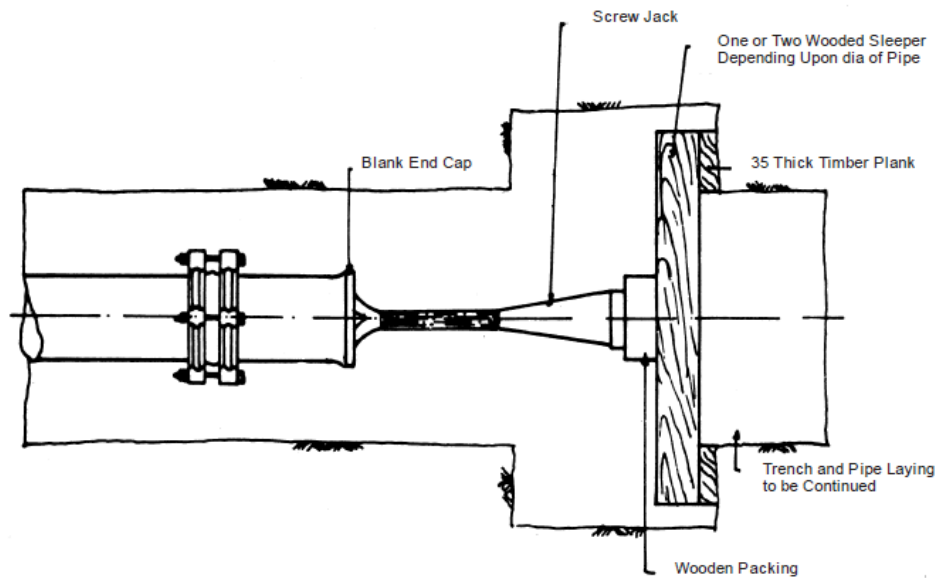
Fig. 18.8 : Thrust Blocks

# HYDROSTATIC TESTS (END CLOSURE FOR PIPES)

Sub Head : Water Supply  
Clause : 18.4.8



FOR PIPES UPTO 125 NOMINAL DIA



FOR PIPES OF NOMINAL DIA OVER 125

Drawing Not to Scale  
All Dimensions are in mm

Fig. 18.9 : Hydrostatic Test (End Closure for Pipes)





**SUB HEAD : 19.0**

**DRAINAGE**



## CONTENTS

| <i>Clause No.</i> | <i>Brief Description</i>                        | <i>Page No.</i> |
|-------------------|---|-----------------|
|                   | List of Bureau of Indian Standards (BIS) Codes  | 1015            |
| 19.0              | Terminology                                     | 1017            |
| 19.1              | General Requirements                            | 1019            |
| 19.2              | Pipes and Specials                              | 1019            |
| 19.2.1            | Glazed Stone Ware Pipes & Fittings              | 1019            |
| 19.2.2            | Cement Concrete Pipes                           | 1023            |
| 19.2.3            | Cast Iron (Centrifugally Cast) Pipes & Specials | 1026            |
| 19.2.4            | Road Gully Grating                              | 1026            |
| 19.3              | Manhole Covers & Frames                         | 1026            |
| 19.4              | Manholes  | 1029            |
| 19.5              | Drop Connection                                 | 1031            |
| 19.6              | Open Surface Drain                              | 1032            |
| 19.7              | Road Gully Chamber with Grating                 | 1032            |
| 19.8              | Brick Masonry Gully Trap                        | 1033            |
| 19.9              | Septic Tank                                     | 1033            |
| 19.10             | Soak Pits 2.5 m dia x 3 m deep                  | 1034            |
| 19.11             | Soak Pit 1.2 x 1.2 x 1.2 m                      | 1035            |
| 19.12             | Dispersion Trench                               | 1035            |
| 19.13             | Desludging of Septic Tanks                      | 1035            |
| 19.14             | Dismantling of old S.W. Pipes                   | 1035            |
| 19.15             | 6 mm thick plastic encapsulated M.S. Foot rest  | 1035            |
| 19.16             | Replacement of M.S. Foot Rests In Manholes      | 1036            |

|              |  |      |
|--------------|--|------|
| 19.17        | Raising of Manhole Cover and Frame Slab  | 1036 |
| 19.18        | Inspection Chamber   | 1037 |
| 19.19        | Non Pressure NP-3 Class (Medium Duty)/ NP-4 Class (Heavy Duty) R.C.C. Pipes  | 1038 |
| Appendix -I  | Dimensional Requirements of Concrete Pipes   | 1042 |
| Appendix -IA | Design Requirement of Reinforced Concrete Collar for Pipe Of Class NP-2  | 1044 |
| Appendix -IB | Design and Strength Test Requirements of Concrete Pipes of Class NP2- Reinforced Concrete, Light Duty, Non-pressure Pipes                                  | 1045 |
| Appendix -IC | Design Requirements of Reinforced Concrete Collars for Pipes of Class NP3 and NP4  | 1046 |
| Appendix -ID | Design and Strength Test Requirements of Concrete Pipes of Class NP3-Reinforced Concrete, Medium Duty, Non-pressure Pipes                                  | 1047 |
| Appendix -IE | Design and Strength Test Requirements of Concrete Pipes of Class NP3-Reinforced Concrete, Medium Duty, Non-pressure Pipes made by Vibrated Casting Process | 1048 |
| Appendix -IF | Design and Strength Test Requirements of Concrete Pipes of Class NP4-Reinforced Concrete, Medium Duty, Non-pressure Pipes                                  | 1049 |
| Appendix -IG | Design and Strength Test Requirements of Concrete Pipes of Class NP4-Reinforced Concrete, Heavy Duty, Non-pressure Pipes made by Vibrated Casting Process  | 1050 |
| Appendix -II | Recommended Sizes of Septic Tanks  | 1052 |
| Fig. 19.1    | Flushing Tank  | 1053 |
| Fig. 19.2    | Gully Trap   | 1054 |
| Fig. 19.3    | Manhole  | 1055 |
| Fig. 19.4    | Manhole (Contd.)   | 1056 |
| Fig. 19.5    | Manhole (Contd.)   | 1057 |

|            |  |      |
|------------|--|------|
| Fig. 19.6  | Manhole (Contd.)   | 1058 |
| Fig. 19.7  | Manhole (Contd.)   | 1059 |
| Fig. 19.8  | Manhole with Drop Connections                                | 1060 |
| Fig. 19.9  | Bedding of Pipes   | 1061 |
| Fig. 19.10 | Joints of Concrete Pipes                                     | 1062 |
| Fig. 19.11 | Bedding/Encasing Stone Ware Pipes                            | 1063 |
| Fig. 19.12 | Brick Masonry Open Surface Drains                            | 1064 |
| Fig. 19.13 | R.C.C. Road Gully Grating                                    | 1065 |
| Fig. 19.14 | Road Gully Chamber   | 1066 |
| Fig. 19.15 | Septic Tank  | 1067 |
| Fig. 19.16 | Septic Tank (Contd.)   | 1068 |
| Fig. 19.17 | Soak Pit   | 1069 |
| Fig. 19.18 | Dispersion Trench  | 1070 |
| Fig. 19.19 | 6mm thick Plastic Encapsulated M.S. Footrest as per IS:10910 | 1071 |
| Fig. 19.20 | 610X455 with Light Duty Cover                                | 1072 |
| Fig. 19.21 | 700X500 with Medium Duty Cover                               | 1073 |
| Fig. 19.22 | 850X600 with Medium Duty Cover                               | 1074 |



### LIST OF BUREAU OF INDIAN STANDARDS (BIS) CODES

| <i>S. No.</i> | <i>BIS. No.</i>   | <i>Subject</i>  |
|---------------|-------------------|---|
| S. No.        | IS No.            | Subject   |
| 1.            | IS 458            | Pre-cast Concrete Pipes (with and without reinforcement).   |
| 2.            | IS 651            | Specification for Salt Glazed Stoneware Pipes and Fittings.   |
| 3.            | IS 783            | Code of Practice for Laying Concrete Pipes  |
| 4.            | IS 1726           | Specification for Cast Iron Manhole Covers and Frames   |
| 5.            | IS 1729           | Cast Iron /Ductile Iron Drainage Pipes and Pipe Fittings Socket and Spigot Series for Over-ground Non-pressure Pipe Line. |
| 6.            | IS 4127           | Code of Practice for Laying of Glazed Stone Ware Pipes  |
| 7.            | IS 4885           | Specifications for Sewer Bricks   |
| 8.            | IS 12592          | Pre-cast Concrete Manhole Covers and Frames - Specifications  |
| 9.            | IS 3114           | Code or Practice for laying of Cast iron pipes.   |
| 10.           | IS 5961           | Specification for cast iron grating for drainage purpose.   |
| 11.           | IS 2470 (Part -1) | Code of practice for Installation of septic tank : Part 1 Design criteria and construction                                |





## 19.0 DRAINAGE

### 19.0 TERMINOLOGY

**Benching (Fig. 19.8):** The sloped floor of a manhole or an inspection chamber on both sides and above the top of the channel.

**Channel:** The open waterway through which sewage, storm water or other liquid waste flow at the invert of a manhole or an inspection chamber.

**Cleaning Eye (Fig. 19.8):** An access opening having a removable cover to enable obstructions to be cleared by means of a drain rod.

**Connections:** The junction of a foul water drain, surface water drains with public sewer, cesspool soak-way or other water courses.

**Flushing Tank (Fig. 19.1) :** Tank used to flush the sewer lime/manholes.

**Curb, Kerb:** The stone margin of a side walk.

**Dispersion Trench:** A trench in which open jointed pipes surrounded by coarse aggregate media and overlaid by fine aggregate, are laid. The effluent from septic tank gets dispersed through the open joints and is absorbed in the surrounding soil.

**Depth of Manhole:** The vertical distance from the top of the manhole to the outgoing invert of the main drain channel.

**Drain:** A line of pipes including all fittings and equipment, such as manholes traps, gullies and floor traps used for the drainage of a building, or a number of buildings or yards appurtenant to the buildings, within the same cartilage. Drain shall also include open channels used for conveying surface water.

**Drainage:** The removal of any liquid by a system constructed for the purpose.

**Drop Connection (Fig. 19.8):** A branch drain of which the last length of piping of the incoming drain, before connection to the sewer, is vertical.

**Drop Manhole (Fig. 19.8):** A manhole incorporating a vertical drop for the purpose of connecting a sewer or drain at high level to one at lowers level.

#### **Effluents**

(a) **Tank Effluent:** The supernatant liquid discharge from a septic tank.

(b) **Filter Effluent:** The liquid discharged from a biological filter.

**Gully Chamber (Fig. 19.2):** The chamber built of masonry around a gully trap, for housing the same.

**Gully Trap (Fig. 19.2):** A trap water seal provided in a drainage system in a suitable position to collect waste water from the scullery, kitchen sink, wash basins, baths and rain water pipes.

**Haunching (Fig. 19.11):** Concrete bedding with additional concrete at the sides of the pipe.

**Junction Pipe:** A pipe incorporating one or more branches.

**Invert:** The lowest point of the interior of a sewer or drain at any cross action.

**Inspection Chamber:** A water tight chamber constructed in any house drainage system which takes wastes from gully traps and disposes off to manhole with access for inspection and maintenance.

**Interceptor Manhole (Interceptor Chamber):** A manhole incorporating an intercepting trap, and providing means of access thereto and equipped with a fresh air inlet on the upstream side of the trap.

**Manhole (Manhole Chamber):** Any chamber constructed on a drain or sewer so as to provide access thereto for inspection testing or the clearance of obstruction.

**Rest Bend (Duck Foot Bend):** A bend supported in a vertical position by a foot formed at its base.

**Saddle:** A purpose made fitting, so shaped as to fit over a hole cut in a sewer or drain, and used to form connections.

**Soffit:** The highest portion of the interior of a sewer or drain at any cross-section.

**Soil Waste:** The discharge from water closets, urinals, slope sinks, stable or cowshed gullies and similar appliances.

**Soil Pipe:** Which receives the discharges from soil fitments, such as water closets urinals, and slope sinks.

**Sullage Waste Water:** Spent water from baths, wash basins kitchen sinks, and similar appliances which does not contain human or animal excreta.

**Sewer:** A closed drain carrying night soil and other water borne waste.

**Surface Water Drain:** A drain conveying surface water including storm water.

**Surface Water:** The run off from precipitation, other water that flows over surface of the ground.

**Sub Soil Water:** Water occurring naturally below the surface of the ground.

**Sludge:** The settled solid matter in semi solid condition.

**Soak Pit (Seepage Pit Soak Way) (Fig. 19.17) :** A pit through which effluent is allowed to seep or leach into the surrounding soil.

**Septic Tank (Fig. 19.15 & 19.16) :** A water tight single storied tank in which sewage is retained sufficiently long to permit sedimentation of suspended solids and partial digestion of settled sludge by anaerobic bacteria.

**Scum:** The greasy and other substances floating on the surface of sewage.

**Vent Pipe:** A pipe line installed to provide flow of air to or from a drainage system or to provide circulation of air within such system to protect trap seals from siphonage and back flow.

**Waste Water:** The discharge from wash basins, sinks and similar appliance, which does not contain human excreta.

### 19.1 GENERAL REQUIREMENTS

**19.1.1** In designing a drainage system for building(s), the aim shall be to provide a self cleansing conduit for the conveyance of soil, waste, surface or sub-surface waters and for the removal of such wastes speedily and efficiently to a sewer or other outlet, without risk of nuisance and hazard to health.

**19.1.2** The discharge of water through a domestic drain is intermittent and limited in quantity and therefore, small accumulations of solid matter are liable to form in the drains between the building and the public sewer. There is usually a gradual shifting of these deposits as discharges take place. Gradients shall be sufficient to prevent these temporary accumulations building up and blocking the drains.

**19.1.3** Normally, the sewer shall be designed for discharging three times the dry weather flow flowing half-full with a minimum self cleansing velocity of 0.75 metre per second. The approximate gradients which give this velocity for the sizes of pipes likely to be used in building drainage and the corresponding discharges when flowing half-full are given in Table 19.1. The sizes and slopes shall conform to Local Municipal Bye-laws.

**19.1.4** In cases, where it is practically not possible to conform to the minimum gradients, a flatter gradient may be used but the minimum velocity in such cases shall on no account be less than 0.61 metres per second.

**19.1.5** On the other hand, it is undesirable to employ gradients giving velocity of flow greater than 2.4 metres per second. Where it is unavoidable, cast iron pipes shall be used. The approximate gradients which give a velocity of 2.4 metres per second for the various sizes of pipes and the corresponding discharge when flowing half-full are given in Table 19.1.

**TABLE 19.1  
Gradients for Sewers**

| Diameter<br>mm | Minimum Gradient |                       | Maximum Gradient |                       |
|----------------|------------------|-----------------------|------------------|-----------------------|
|                | Gradients        | Discharge<br>cum/Min. | Gradients        | Discharge<br>cum/Min. |
| 100            | 1 in 57          | 0.18                  | 1 in 5.6         | 0.59                  |
| 150            | 1 in 100         | 0.42                  | 1 in 9.7         | 1.32                  |
| 200            | 1 in 145         | 0.73                  | 1 in 14          | 2.4                   |
| 230            | 1 in 175         | 0.93                  | 1 in 17          | 2.98                  |
| 250            | 1 in 195         | 1.10                  | 1 in 19          | 3.60                  |
| 300            | 1 in 250         | 1.70                  | 1 in 24.5        | 5.30                  |

### 19.2 PIPES AND SPECIALS

#### 19.2.1 Glazed Stone Ware Pipes and Fittings

All pipes with spigot and socket ends and fittings shall conform to class SP1 of IS 651. These shall be sound, free from visible defects such as fire cracks or hair cracks. The glaze of the pipes shall be free from crazing. The pipes shall give a sharp clear tone when struck with a light hammer. There shall be no broken blisters. The thickness of pipes shall be as given in the Table 19.2.

**TABLE 19.2**  
**Stoneware Pipes**

| <i>Internal Diameter (mm)</i> | <i>Mean Thickness of the Barrel and Socket (mm)</i> |
|-------------------------------|---|
| 100                           | 12  |
| 150                           | 15  |
| 200                           | 16  |
| 230                           | 19  |
| 250                           | 20  |
| 300                           | 25  |
| 350                           | 30  |
| 400                           | 35  |
| 450                           | 37  |

The length of pipes shall be 60, 75, 90 cm exclusive of the internal depth of the socket. The pipes shall be handled with sufficient care to avoid damage to them.

**19.2.1.1 S.W. Gully Trap (Fig. 19.2):** Gully traps shall conform to IS 651. These shall be sound, free from visible defects such as fire cracks, or hair cracks. The glaze of the traps shall be free from crazing. They shall give a sharp clear tone when struck with light hammer. There shall be no broken blisters.

Each gully trap shall have one C.I. grating of square size corresponding to the dimensions of inlet of gully trap. It will also have a water tight C.I. cover with frame inside dimensions 300 x 300 mm the cover weighing not less than 4.50 Kg and the frame not less than 2.70 Kg. The grating, cover and frame shall be of sound and good casting and shall have truly square machined seating faces.

**19.2.1.2 Laying and Jointing Stone Ware Pipes :** For all sewers and drains, glazed stoneware pipes shall be used as far as possible in preference to other types of pipes. These are suitable, particularly where acid effluents or acid sub-soil conditions are likely to be encountered.

(i) *Trenches:* Specifications described in 19.2.2.1 shall apply, as far as possible.

The trench shall be so dug that the pipe can be laid to the required alignment and at the required depth. When the pipe line is under a roadway, a minimum cover of 90 cm is recommended for adoption, but it may be modified to suit local conditions. The trench shall be excavated only so far in advance of pipe laying as specified by the Engineer-in-Charge. The trench shall be so shored and drained that the workmen may work therein safely and efficiently. The discharge of the trench dewatering pumps shall be conveyed either to drainage channels or to natural drains.

The excavation shall be carried out with manual labour or with suitable mechanical equipment as approved by the Engineer-in-Charge.

Unless otherwise specified by the Engineer-in-Charge, the width at bottom of trenches for different diameters of pipes laid at different depths shall be as given below:—

- (a) For all diameters, up to an average depth of 120 cm, width of trench in cm = diameter of pipe + 30 cm.
- (b) For all diameters for depths above 120 cm, width of trench in cm = diameter of pipe + 40 cm.
- (c) Notwithstanding (a) and (b) the total width of trench shall not be less than 75 cm for depths exceeding 90 cm.

The width of trench in the upper reaches shall be increased as described in sub-head 'Earthwork'.

- (ii) *Laying (Fig. 19.11)* : Where the pipes are laid on soft soil with maximum water table lying at invert level of the pipe, the pipes shall be bedded in cement concrete with thickness and mix as specified, projecting on each side of the pipe to the specified width of the trench (Fig. 19.11(i)). The pipes with their crown level at 1.20 m depth and less from ground shall be covered with 15 cm thick. Concrete above the crown of the pipe and sloped off to meet the outer edges of the concrete, to give a minimum thickness of 15 cm all-around the pipe (Fig. 19.11 (iii)). Pipes laid at a depth greater than 1.20 m at crown and maximum water table level rising above the invert level of pipe, shall be concreted at the sides up to the level of the centre of the pipe and sloped off from the edges to meet the pipe tangentially (Fig. 19.11(ii)).

The pipe shall be carefully laid to the alignments, levels and gradients shown on the plans and sections. Great care shall be taken to prevent sand etc. from entering the pipes. The pipes between two manholes shall be laid truly in a straight line without vertical or horizontal undulation. The pipes shall be laid with socket ends facing upstream. The body of the pipe shall for its entire length rest on an even bed of concrete and places shall be excavated in the concrete to receive the socket of the pipe.

Where pipes are not bedded on concrete, the trench floor shall be left slightly high and carefully bottomed up as pipe laying proceeds, so that the pipe barrels rest on firm and undisturbed ground. If the excavation has been carried too low, the desired levels shall be made up with concrete 1:5:10 (1 cement: 5 fine sand: 10 graded stone aggregate 40 mm nominal size) for which no extra payment shall be made.

If the floor of the trench consists of rock or very hard ground that cannot easily be excavated to smooth surface the pipe shall be laid on a levelling course of concrete as desired.

When S.W. pipes are used for storm water drainage, no concreting will normally be necessary. The cement mortar for jointing will be 1:3 (1 cement: 3 fine sand). Testing of joints will also not be done.

- (iii) *Jointing* : Tarred gasket or hemp yarn soaked in thick cement slurry shall first be placed round the spigot of each pipe and the spigot shall then be slipped home well into the socket of the pipe previously laid. The pipe shall then be adjusted and fixed in the correct position and the gasket caulked tightly home so as to fill not more than 1/4th of the total depth of the socket.

The remainder of the socket shall be filled with stiff mixture of cement mortar in the proportion of 1:1 (1 cement: 1 fine sand). When the socket is filled, a fillet shall be formed round the joint with a trowel forming an angle of 45 degree with the barrel of the pipe.

After a day's work any extraneous material shall be removed from the inside of the pipe. The newly made joints shall be cured for at least seven days.

- (iv) *Testing of Joints* : Stoneware pipes used for sewers shall be subjected to a test pressure of 2.5 m head of water at the highest point of the section under test. Before commencing test, the pipeline shall be filled with water and maintained full for 24 hours under head of 0.6 m of water. The test shall be carried out by suitably plugging the lower end of the drain and the ends of the connection if any and filling the system with water. A knuckle bend shall be temporarily jointed in at the top end and a sufficient length of vertical pipe jointed to it so as to provide the required test head, or the top may be plugged with a connection to a hose ending in a funnel which could be raised or lowered till the required head is obtained and fixed suitable for observation. The tolerance of two liters per centimeter of diameter per kilometer may be allowed during a period of 10 minutes.

If any leakage is visible, the defective part of the work shall be cut out and made good. A slight amount of sweating which is uniform may be overlooked, but excessive sweating from a particular pipe or joint shall be watched for and taken as indicating a defect to be made good.

Any joint found leaking or sweating, shall be rectified or embedded into 15 cm layer of cement concrete (1:2:4) 30 cm in length and the section retested.

- (v) *Refilling* : In cases where pipes are not bedded on concrete special care shall be taken in refilling trenches to prevent the displacement and subsequent settlement at the surface resulting in uneven street surfaces and dangers to foundations etc. The backfilling materials shall be packed by hand under and around the pipe, and rammed with a shovel and light tamper. This method of filling will be continued up to the top of pipe. The refilling shall rise evenly on both sides of the pipe continued up to 60 cm above the top of pipe so as not to disturb the pipe. No tamping should be done within 15 cm of the top of pipe.
- (vi) *Measurements* : The lengths of pipes shall be measured in running metres nearest to a cm as laid or fixed, from inside of one manhole to the inside of the other manhole. The length shall be taken along the centre line of the pipes over all fittings such as bends, junctions, etc. which shall not be measured separately.

Excavation, refilling, shoring and timbering in trenches, and cement concreting wherever required shall be measured separately under relevant items of work.

- (vii) *Rate* : The rate shall include the cost of materials and labour involved in all the operations described above excluding the cost of concrete which shall be paid for separately.

#### **19.2.1.3 Fixing S.W. Gully Trap (Fig. 19.2)**

- (i) *Excavation* : The excavation for gully traps shall be done true to dimensions and levels as indicated on plans or as directed by the Engineer-in-Charge.
- (ii) *Fixing* : The gully traps shall be fixed on cement concrete foundation 65 cm square and not less than 10 cm thick. The mix for the concrete will be 1:5:10 (1 cement: 5 fine sand: 10 graded stone aggregate 40 mm nominal size). The jointing of gully outlet to the branch drain shall be done similar to jointing of S.W. pipes described above.
- (iii) *Brick Masonry Chamber* : After fixing and testing gully and branch drain, a brick masonry chamber 300 x 300 mm (inside) in brick work of specified class in cement mortar 1:4 (1 cement: 4 fine sand) shall be built with a half brick thick brick work round the gully trap from the top of the bed concrete up to ground level. The space between the chamber walls and the trap shall be filled in with cement concrete 1:5:10 (1 cement: 5 fine sand: 10 graded stone aggregate 40 mm nominal size). The upper portion of the chamber i.e. above the top level of the trap shall be plastered inside with cement mortar 1:3 (1 cement: 3 coarse sand), finished with a floating coat of neat cement. The corners and bottom of the chamber shall be rounded off so as to slope towards the grating.

C.I. cover with frame 300 × 300 mm (inside) shall then be fixed on the top of the brick masonry with cement concrete 1:2:4 (1 cement: 2 coarse sand: 4 graded stone aggregate 20 mm nominal size) and rendered smooth. The finished top of cover shall be left about 4 cm above the adjoining ground level so as to exclude the surface water from entering the gully trap.

- (iv) *Measurements* : The work shall be enumerated. Excavation shall be measured separately under relevant item of earth work.
- (v) *Rate* : The rate shall include the cost of materials and labour involved in all the operations described above, except earth work which shall be paid for separately.

### 19.2.2 Cement Concrete Pipes (with and without Reinforcement) (Light Duty, Non-Pressure)

The pipes shall be with or without reinforcement as required and shall be of class not lesser than NP2. These shall conform to IS 458 and shall be capable of withstanding a test pressure of 0.07 MPa (7 m head). The reinforced cement concrete pipes shall be manufactured by centrifugal (or spun) process while un-reinforced cement concrete pipes by spun or pressure process. All pipes shall be true to shape, straight, perfectly sound and free from cracks and flaws. The external and internal surface of the pipes shall be smooth and hard. The pipes shall be free from defects resulting from imperfect grading of the aggregate mixing or moulding.

Concrete used for the manufacture of un-reinforced and reinforced concrete pipes and collars shall not be leaner than 1:2:4 (1 cement: 2 coarse sand: 4 graded stone aggregate). The maximum size of aggregate should not exceed one third of the thickness of the pipe or 20 mm whichever is smaller for pipes above 250 mm internal diameter. But for pipes of internal diameter 80 to 250 mm, the maximum size of aggregate should be 10mm. The reinforcement in the reinforced concrete pipes shall extend throughout the length of the pipe. The circumferential and longitudinal reinforcements shall be adequate to withstand the specified hydrostatic pressure and further bending stresses due to the weight of water when running full across a span equal to the length of pipe plus three times its own weight.

The dimensional requirements of concrete pipes are given in Appendix I.

The minimum clear cover for reinforcement in pipes and collars shall be as given in Table 19.3.

**TABLE 19.3**

| <i>Sl. No.</i> | <i>Precast concrete pipe/collar</i> | <i>Minimum clear cover, mm</i> |
|----------------|-------------------------------------|--------------------------------|
| (i)            | Barrel wall thickness               |                                |
| (a)            | Upto and including 75 mm            | 8                              |
| (b)            | Over 75 mm                          | 15                             |
| (ii)           | At spigot steps                     | 5                              |
| (iii)          | At end of longitudinal              | 5                              |

**Note :** An effective means shall be provided for maintaining the reinforcement in position and for ensuring correct cover during manufacture of the unit. Spacers for this purpose shall be of rust proof material or of steel protected against corrosion.

#### 19.2.2.1 Laying and Jointing Cement Concrete Pipes and Specials

- (i) **Trenches:** Trenches shall be as described in 18.4.4. Where the pipes are to be bedded directly on soil, the bed shall be suitably rounded to fit the lower part of the pipe, the cost for this operation being included in the rate for laying the pipe itself.
- (ii) Loading, transporting and unloading of concrete pipes shall be done with care. Handling shall be such as to avoid impact. Gradual unloading by inclined plane or by chain pulley block is recommended. All pipe sections and connections shall be inspected carefully before being laid. Broken or defective pipes or connections shall not be used. Pipes shall be lowered into the trenches carefully. Mechanical appliances may be used. Pipes shall be laid true to line and grade as specified. Laying of pipes shall proceed upgrade of a slope.
- (iii) If the pipes have spigot and socket joints, the socket ends shall face upstream. In the case of pipes with joints to be made with loose collars, the collars shall be slipped on before the next pipe is laid. Adequate and proper expansion joints shall be provided where directed.



- (iv) In case where foundation conditions are unusual such as in the proximity of trees or holes, under existing or proposed tracks manholes etc. the pipe shall be encased all-around in 15 cm thick cement concrete 1:5:10 (1 cement : 5 fine sand : 10 graded stone aggregate 40 mm nominal size) or compacted sand or gravel.
- (v) In cases where the natural foundation is inadequate the pipes shall be laid either in concrete cradle supported on proper foundations or on any other suitably designed structure. If a concrete cradle bedding is used the depth of concrete below the bottom of the pipe shall be at least 1/4th of the internal dia of the pipe subject to the min. of 10 cm and a maximum of 30 cm. The concrete shall extend up the sides of the pipe at least to a distance of 1/4th of the outside diameter of pipes 300 mm and over in dia. The pipe shall be laid in this concrete bedding before the concrete has set. Pipes laid in trenches in earth shall be bedded evenly and firmly and as far up the haunches of the pipe as to safely transmit the load expected from the backfill through the pipe to the bed. This shall be done either by excavating the bottom of the trench to fit the curve of the pipe or by compacting the earth under around the curve of the pipe to form an even bed. Necessary provision shall be made for joints wherever required.
- (vi) When the pipe is laid in a trench in rock hard clay, shale or other hard material the space below the pipe shall be excavated and replaced with an equalising bed of concrete, sand or compacted earth. In no place shall pipe be laid directly on such hard material.
- (vii) The method of bedding and laying the pipes under different conditions are illustrated in Fig. 19.9.
- (viii) When the pipes are laid completely above the ground the foundations shall be made even and sufficiently compacted to support the pipe line without any material settlement. Alternatively the pipe line shall be supported on rigid foundations at intervals. Suitable arrangements shall be made to retain the pipe line in the proper alignment, such as by shaping the top of the supports to fit the lower part of the pipe. The distance between the supports shall in no case exceed the length of the pipe. The pipe shall be supported as far as possible close to the joints. In no case shall the joints come in the centre of the span. Care shall be taken to see that super imposed loads greater than the total load equivalent to the weight of the pipe when running full shall not be permitted.

Suitably designed anchor blocks at change of direction and grades for pressure lines shall be provided where required.

- (ix) **Jointing:** Joints are generally of rigid type. Where specified flexible type joints may also be provided.
  - (a) *Rigid Spigot and Socket Joint (Fig. 19.10):* The spigot of each pipe shall be slipped home well into the socket of the pipe previously laid and adjusted in the correct position. The opening of the joint shall be filled with stiff mixture of cement mortar in the proportion of 1:2 (1 cement: 2 fine sand) which shall be rammed with caulking tool. After a day's work any extraneous material shall be removed from the inside of the pipe and the newly made joint shall be cured.
  - (b) *Rigid Collar Joint (Fig. 19.10):* The two adjoining pipes shall be butted against each other and adjusted in correct position. The collar shall then be slipped over the joint, covering equally both the pipes. The annular space shall be filled with stiff mixture of cement mortar 1:2 (1 cement: 2 fine sand) which shall be rammed with caulking fool. After a day's work any extraneous materials shall be removed from the inside of the pipe and the newly made joint shall be cured.

- (c) *Semi Flexible Spigot and Socket Joint (Fig. 19.10)*: The joint is composed of specially shaped spigot and socket ends on the concrete pipes. A rubber ring shall be placed on the spigot which shall be forced into the socket of the pipe previously laid. This compresses the rubber ring as it rolls into the annular space formed between the two surfaces of the spigot and the socket, stiff mixture of cement mortar 1:2 (1 cement: 2 fine sand) shall then be filled into the remaining annular space and rammed with a caulking tool. After day's work any extraneous materials shall be removed from the inside of the pipe and the newly made joint shall be cured.
- (d) *Semi Flexible Collar Joint: This is made up of a loose collar which covers two specially shaped pipe ends as shown in the Fig. 19.10. Each end shall be fitted with a rubber ring which when compressed between the spigot and the collar, seal the joint. Stiff mixture of cement mortar 1:2 (1 cement: 2 fine sand), shall then be filled into the remaining annular space and rammed with a caulking tool. After day's work, any extraneous material shall be removed from the inside of the pipe and the newly made joint shall be cured.*
- (e) *Internal Flush Joint (Fig. 19.10)*: This joint is generally used for culvert pipe of 60 cm dia and over. The ends of the pipe are specially shaped to form a self centering joint with an internal jointing space 1.3 cm wide the finished joint is flush with both inside and outside with the pipe wall as shown in Fig. 19.10. The jointing space is filled with cement mortar 1:2 (1 cement: 2 fine sand) mixed sufficiently dry to remain in position when forced with a trowel or rammer. After day's work, any extraneous material shall be removed from the inside of the pipe and the newly made joint shall be cured.
- (f) *External Flush Joint* : This joint is suitable for pipes which are too small for jointing from inside. This joint is composed of specially shaped pipe ends as shown in Fig. 19.10. Each end shall be butted against each other and adjusted in correct position. The jointing space shall then be filled with cement mortar 1:2 (1 cement: 2 fine sand) sufficiently dry and finished off flush. Great care shall be taken to ensure that the projecting ends are not damaged as no repairs can be readily affected from inside the pipe.
- (x) In all pressure pipe lines the recess at the end of the pipe line shall be filled with jute braiding dipped in hot bitumen or other suitable approved compound. Pipes shall be so jointed that the bitumen ring of one pipe shall set into the recess of the next pipe. The ring shall be thoroughly compressed by jacking or by any other suitable method.

The number of pipes that shall be jacked together at a time shall depend on the diameter of the pipes and the bearing capacity of the soil, for small pipes up to 25 cm diameter, six pipes can be jacked together at a time.

The quantity of jute and bitumen in the ring shall be just sufficient to fill the recess in the pipe when pressed hard by jacking or by any other suitable method. Before and during jacking care shall be taken to see that there is no offset at the joint.

- (xi) *Testing*: For pressure pipes, the completed pipeline shall be tested for pressure (Known as site test pressure) which shall not be less than the maximum pipeline operating pressure plus the calculated surge pressure, but in no case shall it exceed the hydrostatic test pressure. For non-pressure pipes the joints shall be tested as per procedure laid down under Para 19.2.1.2 (iv).

(xii) *Refilling of Trenches:* The specification described in 19.2.1.2 (v) shall apply. In case where pipes are not bedded on concrete special care shall be taken in refilling, trenches to prevent the displacement and subsequent settlement at the surface resulting in uneven street surfaces and dangers to foundations etc. The backfilling materials shall be packed by hand under and around the pipe and rammed with a shovel and light tamper. This method of filling will be continued up to the top of pipe. The refilling shall rise evenly on both sides of the pipe and continued up to 60 cm above the top of pipe so as not to disturb the pipe. No tamping shall be done within 15 cm of the top of pipe. The tamping shall become progressively heavier as the depth of the backfill increases.

(xiii) *Measurements :* The lengths of pipes shall be measured in running metres nearest to a cm as laid or fixed, from inside of one manhole to the inside of the other manhole. The length shall be taken along the centre line of the pipes over all fittings such as bends, collars, junctions, etc. which shall not be measured separately.

Excavation, refilling, shoring and timbering in trenches, and cement concreting wherever required shall be measured separately under relevant items of work.

(xiv) *Rate:* The rate shall include the cost of materials and labour involved in all the operations described above.

### 19.2.3 Cast Iron (Centrifugally Cast) Pipes and Specials

Cast iron (centrifugally cast) pipes and specials shall conform to the specifications described in 18.3.10.

### 19.2.4 Road Gully Grating (Fig. 19.13)

**19.2.4.1 Horizontal Gully Grating:** The casting of the grating and frames shall be the same as that of manhole covers described in 19.2.2.1. The gully grating cover shall be hinged to the frame to facilitate its opening for cleaning and repairs. A typical grating is shown in Fig. 19.13 & 19.14. The weight of grating shown in Figure shall be minimum 75 Kg. In case of R.C.C. horizontal gully grating it shall be in cement concrete 1:1:2 (1 cement: 1 coarse sand: 2 graded stone aggregate 20 mm nominal size) as shown in Fig. 19.13.

**19.2.4.2 Vertical Gully Grating:** The chamber shall be of brick masonry, 12 mm dia, round bar shall be fixed in cement concrete block at the bottom. The bars at the top shall be welded or riveted to M.S. flat 40×6 mm as shown in Fig. 19.14.

**19.2.4.3 Horizontal and Vertical Gully Grating:** The details of typical road gully chamber of brick masonry with horizontal and vertical grating shall be as given in Fig. 19.14.

## 19.3 MANHOLE COVERS & FRAMES

### 19.3.1 Manhole Covers

The covers and frames shall conform to IS 1726 for cast Iron and IS 12592 for pre-cast concrete covers and shall be of the following grades and types.

| Grades           | Grade Designation | Type/shape of cover   |
|------------------|-------------------|---|
| Light Duty       | LD - 2.5          | Rectangular, Square, Circular   |
| Medium Duty      | MD - 10           | Rectangular, Circular and Square (for pre-cast concrete manhole covers) |
| Heavy Duty       | HD - 20           | Circular-Square, Rectangular, (Scrapper Manhole)                        |
| Extra Heavy Duty | EHD - 35          | Circular, Square, Rectangular, (Scrapper Manhole)                       |

### **19.3.1.1 Cast Iron Manhole Covers and Frames**

- (i) Manhole covers and frame shall be manufactured from appropriate grade of grey cast iron not inferior than FG150 grade of IS 210.
- (ii) They shall be cleanly cast and shall be free from air and sand holes, cold shuts and warping.
- (iii) Covers shall have on its operative top a raised chequered design to provide for an adequate no-slip grip. The rise of chequers shall be not less than 4mm.
- (iv) Key holes, keys and lifting devices shall be provided in the manhole covered to facilitate their placement in the frames and their operative maintenance.
- (v) Manhole covers and frames shall be coated with materials having base with a black bituminous composition. The coating shall be smooth and tenacious. It shall not flow when exposed to temperature of 63°C and shall not be so brittle as to chip off at temperature of 0°C.
- (vi) Size and shape and performance requirement of manhole covers and frames shall conform to IS 1726.
- (vii) Each manhole covers and frame shall have cast on them the following information:
  - (a) Manufacturer's name or trade-mark
  - (b) Grade designation
  - (c) Date of manufacturer
  - (d) The words SWD or 'Sewer' to denote 'storm water drain' or 'sewer' respectively
  - (e) Identification marks as required by Engineer-in-Charge.
- (viii) The cover shall be gas tight and water tight.
- (ix) The sizes of covers specified shall be taken as the clear internal dimensions of the frame.
- (x) The approximate weight of the various type of manhole covers and frames shall be as per IS 1726.
- (xi) The cover shall be capable of easy opening and closing and it shall be fitted in the frame in workmanship like manner.

### **19.3.2 Pre-Cast Concrete Manhole Covers & Frames**

Pre-cast reinforced cement concrete manhole covers intended for use in sewerage and water works shall generally conform to IS 12592.

#### **19.3.2.1 Materials**

*Cement:* Cement used for the manufacture of pre-cast concrete manhole covers shall be 43 grade Portland cement conforming to IS-8112.

*Aggregates:* The aggregates used shall be clean and free from deleterious matter and shall conform to the requirements of IS -383. The aggregates shall be well graded and the nominal maximum size of coarse aggregate shall not exceed 20 mm.

*Concrete:* The mix proportions of concrete shall be determined by the manufacturer and shall be such as will produce a dense concrete without voids, honey combing etc. The minimum cement content in the concrete shall be 410 kg/m<sup>3</sup> with a maximum water cement ratio of 0.45. Concrete weaker than grade M-30 (design mix) shall not be used. Compaction of concrete shall be done by machine vibration.

### Reinforcement

- (a) The reinforcement steel shall conform to IS 1786. Reinforcement shall be clean and free from loose mill scale, loose rust, and mud, oil, grease or any other coating which may reduce or destroy the bond between the concrete and steel. A light film of rust may not be regarded as harmful but steel shall not be visibly pitted by rust.
- (b) *Fibers Steel*: The diameter/equivalent diameter of steel fibers where used, shall not be greater than 0.75 mm. The aspect ratio shall be in the range of 50 to 80. The minimum volume of fibers shall be 0.5 percent of the volume of concrete.

The reinforced concrete manhole cover and frame shall be designed in accordance with the provisions of IS 456. Clear cover to reinforcement shall not be less than 15 mm.

**19.3.2.2 Shapes and Dimensions:** Shape, dimensions and tolerance of pre-cast concrete manhole covers and frames shall conform to IS 12592. Outside dimension of cover at top shall match with corresponding frame so that the maximum clearance at top between the frame and the cover all round the periphery is not more than 5 mm and the top surface of the frame and covers, is in level within a tolerance of  $\pm 5$  mm.

For facility of removing the cover from the frame, suitable taper matching with taper given for the frame shall be provided to the periphery of the cover.

**19.3.2.3 Lifting Device:** The minimum diameter of mild steel rod used as lifting device shall be 12 mm for light and medium duty covers and 16 mm for heavy and extra heavy duty covers. The lifting device shall be protected from corrosion by hot galvanising or epoxy coating or any other suitable treatment.

**19.3.2.4 Finishing & Coating:** To prevent any possible damage from corrosion of steel the underside of the covers shall be treated with anticorrosive paint. The top surface of the covers shall be given a chequered finish.

In order to protect the edges of the covers from possible damage at the time of lifting and handling it is necessary that the manhole covers shall be cast with a protective mild steel sheet of minimum 2.5 mm thickness around the periphery of the covers. Exposed surface of mild steel sheet shall be given suitable treatment with anticorrosive paint or coating. To prevent the top outer edge of frame from possible damages, it shall be protected by 25 mm X 3 mm mild steel flat as part of the frame.

### 19.3.2.5 Physical Requirements

- (a) *General*: All units shall be sound and free from cracks and other defects which interface with the proper placing of the unit or impair the strength or performance of the units. Minor chipping at the edge/surface resulting from the customary methods of handling during delivery shall not be deemed for rejecting.
- (b) *Load Test*: The breaking load of individual units when tested in accordance with the method described in IS 12592 shall be not less than the values specified in Table 19.4.

**TABLE 19.4**

| Grade of Cover | Type                            | Load in Tonnes | Diameter of Blocks in mm |
|----------------|---------------------------------|----------------|--------------------------|
| EHD - 35       | Circular, Square or Rectangular | 35             | 300                      |
| HD - 20        | Circular, Square or Rectangular | 20             | 300                      |
| MD - 10        | Circular or Rectangular         | 10             | 300                      |
| LD - 2.5       | Rectangular, Square or Circular | 2.5            | 300                      |

**19.3.2.6 Fixing:** The frames of manhole shall be firmly embedded to correct alignment and level in RCC slab or plain concrete as the case may be on the top of masonry which shall be paid as extra unless specified otherwise.

**19.3.2.7 Measurements:** The manhole covers shall be enumerated under relevant items.

**19.3.2.8 Rates:** The rate shall include the cost of materials and labour involved in all the operation described above except fixing of frames and covers which shall be paid as extra unless specified otherwise in the item.

**19.3.2.9 Foot Rests:** Foot rests shall be of 20 mm M.S. square or round bars as specified.

#### **19.4 MANHOLES (FIG. 19.3 to 19.8)**

At every change of alignment, gradient or diameter of a drain, there shall be a manhole or inspection chamber. Bends and junctions in the drains shall be grouped together in manhole as far as possible. The maximum distance between manholes shall be 30 m.

Manholes of different types and sizes as specified shall be constructed in the sewer line at such places and to such levels and dimensions as shown in the drawings or as directed by the Engineer-in-Charge. The size specified shall indicate the inside dimensions between brick faces of the manholes.

Where the diameter of the drain is increased, the crown of the pipe shall be fixed at the same level and necessary slope given in the invert of the manhole chamber. In exceptional cases and where unavoidable, the crown of the branch sewer may be fixed at lower level but in such cases the peak flow level of the two sewers shall be kept the same.

Sewers of unequal sectional area shall not be jointed at the same invert in a manhole. The invert of the smaller sewer at its junction with main shall be at least  $\frac{2}{3}$  the diameter of the main above the invert of the main. The branch sewers shall deliver sewage in the manhole in the direction of main flow and the junction must be made with care so that flow in main is not impeded.

No drain from house fittings, e.g. gully trap or soil pipe, etc. to manhole shall normally exceed a length of 6 m unless it is unavoidable.

Manholes 90 × 80 cm are generally constructed within compound for house drainage only and near the buildings for house drainage. Manholes 1.2 m × 90 cm are generally constructed for main drainage work for depths less than 1.5 m.

Manhole 1.4 m × 90 cm is of the arched type and is generally constructed for main drainage works where depth is 1.50 m or more. The width of manholes shall be increased more than 90 cm on bends or junctions or pipes with diameter greater than 450 mm and that the benching width on either side of the channel is minimum 20 cm.

Manholes 1.4 m internal diameter are generally constructed for main drainage works where depth is 2.45 m or more as an alternative to manholes of arch type. The diameter shall be increased suitably, for pipes with diameter greater than 450 mm in the same manner as in the case of rectangular manholes.

Before deciding size of manholes, Local Municipal Bye Laws shall be consulted. As a general guide some typical type designs of manholes followed in Delhi have been shown in Fig. 19.4 to 19.7. When manholes are constructed on foot path, these shall be provided with cover of medium duty casting and when built within the width of the road under vehicular traffic, these shall be provided with cover of heavy duty casting.

##### **19.4.1 Excavation**

The excavation for manhole shall be true to dimensions and levels shown on the plans or as directed by the Engineer-in-Charge.



#### 19.4.2 Bed Concrete

The manhole shall be built on a bed of cement concrete 1:4:8 (1 cement: 4 coarse sand: 8 graded stone aggregate 40 mm nominal size) unless required by local authorities. The thickness of the bed concrete shall be 20 cm for manholes up to 4.25 m depth and 30 cm for depths beyond 4.25 m unless otherwise specified or directed by the Engineer-in-Charge. In bad ground, special foundations as suitable shall be provided.

#### 19.4.3 Brick Work

The brick work shall be with class 75 bricks in cement mortar 1:4 (1 cement: 4 coarse sand). The external joints of the brick masonry shall be finished smooth, and the joints of the pipes with the masonry shall be made perfectly leak proof. For arched type and circular manholes, brick masonry in arches and arching over the pipes shall be in cement mortar 1:3 (1 cement: 3 fine sand). In the case of manholes of circular type the excess shaft shall be corbelled inwardly on three sides at the top to reduce its size to the cover frame to be fitted.

The walls shall be built of one brick thickness for depths up to 4.25 m. Below a depth of 4.25 m in ordinary subsoil the wall thickness shall be increased to one and half brick and at 9.75 m below ground two brick thick walls shall be built.

#### 19.4.4 Plaster and Pointing

The walls of the manholes shall be plastered inside with 12 mm thick cement plaster 1:3 (1 cement: 3 coarse sand) finished smooth. In the case of arched type manhole the walls of the manhole shall be plastered inside all-around only up to the crown level, and flush pointed for the shaft with cement mortar 1:2 (1 cement: 2 fine sand). Where the saturated soil is met with, also the external surface of the walls of the manhole shall be plastered with 12 mm thick cement plaster 1:3 (1 cement: 3 coarse sand) finished smooth up to 30 cm above the highest sub-soil water level with the approval of the Engineer-in-Charge. The plaster shall further be water proofed with addition of approved water proofing compound in a quantity as per manufacturer's specifications. In case Local Authorities/Bye Laws specify richer specifications, the same shall be adopted.

For earth work excavation, bed concrete brick work, plaster and pointing, R.C.C. work and refilling of earth, respective specifications shall be followed.

#### 19.4.5 Benching

The channels and benching shall be done in cement concrete 1:2:4 (1 cement: 2 coarse sand: 4 graded stone aggregate 20 mm nominal size) and rendered smooth with neat cement. The depth of channels and benching shall be as given in Table 19.5.

#### 19.4.6 Foot Rests (Fig. 19.8)

All manholes deeper than 0.8 m shall be provided with M.S. foot rests. These shall be embedded 20 cm deep in 20 x 20 x 10 cm blocks of cement concrete 1:3:6 (1 cement: 3 coarse sand 6 graded stone aggregate 20 mm nominal size). The concrete block with M.S. foot rest placed in its centre shall be cast in situ along with the masonry and surface finished with 12 mm thick cement plaster 1:3 (1 cement: 3 coarse sand) finished smooth.

**TABLE 19.5**

| <i>Sizes of drain<br/>(mm)</i> | <i>Top of channel at the centre above<br/>bed concrete<br/>(cm)</i> | <i>Depth of benching at side walls above<br/>bed concrete<br/>(cm)</i> |
|--------------------------------|---|--|
| 100                            | 15  | 20   |
| 150                            | 20  | 30   |
| 200                            | 25  | 35   |
| 250                            | 30  | 40   |
| 300                            | 35  | 45   |
| 350                            | 40  | 50   |
| 400                            | 45  | 55   |
| 450                            | 50  | 60   |

Foot rests which shall be of 20 × 20 Sq. M.S. bars as shown in Fig. 19.8 shall be fixed 40 cm apart vertically and staggered laterally and shall project 10 cm beyond the surface of the wall. The top foot rest shall be 45 cm below the manhole cover.

Foot rests shall be painted with coal tar, the portion embedded in the cement concrete block being painted with thick cement slurry before fixing.

#### **19.4.7 Manhole Covers and Frames**

The frame of manhole shall be firmly embedded to correct alignment and levels in R.C.C. slab or plain concrete as the case may be on the top of the masonry. After completion of the work, manhole covers shall be sealed by means of thick grease.

#### **19.4.8 Measurements**

Manholes shall be enumerated under relevant items. The depth of the manhole shall be reckoned from the top level of C.I. cover to the invert level of channel. The depth shall be measured correct to a cm. The extra depth shall be measured and paid as extra over the specified depth.

#### **19.4.9 Rate**

The rate shall include the cost of materials and labour involved in all the operations described above but excludes the cost of (i) excavation, (ii) M.S. foot rests and (iii) 12 mm thick cement plaster with water proofing material applied at the external surface of the manhole if required. These items shall be paid for separately under relevant items of work.

Payment for extra depths of manholes shall be made separately under relevant items of work.

### **19.5 DROP CONNECTION (FIG. 19.8)**

**19.5.0** In cases where branch pipe sewer enters the manhole of main pipe sewer at a higher level than the main sewer, a drop connection shall be provided. The work shall be carried out as per Fig. 19.8. S.C.I. pipes and special conforming to IS 1729 shall be of the same size as that of the branch pipe sewer.

For 150 and 250 mm main line, if the difference in level between the water line (peak flow level) and the invert level of the branch line is less than 60 cm, a drop connection may be provided with in the manhole by giving suitable ramp. If the difference in level is more than 60 cm, the drop shall be provided externally.

The main lines up to 350 mm dia, are designed for half depth of flow, from 350 mm to 900 mm for 2/3 depth of flow and beyond 900 mm for 3/4 depth of flow.

#### **19.5.1 Excavation**

The excavation shall be done for the drop connection at the place where the branch line meets the manhole. The excavation shall be carried up to the bed concrete of the manhole and to the full width of the branch line.

#### **19.5.2 Laying**

At the end of branch sewer line S.C.I. cross shall be fixed to the line which shall be extended through the wall of the manhole by a horizontal piece of S.C.I. pipe to form an inspection or cleaning eye. The open end shall be provided with chain and lid. The S.C.I. drop pipe shall be connected to the cross at the top and to the S.C.I. bend at the bottom. The bend shall be extended through the wall of the manhole by a piece of C.I. pipe which shall discharge into the channel. Necessary channel shall be made with cement concrete 1:2:4 (1 cement: 2 coarse sand: 4 graded stone aggregate 20 mm nominal size) and finished smooth to connect the main channel. The joint between



S.C.I. pipe and fittings shall be lead caulked as described in 18.5.3. The joint between S.C.I. cross and S.W. branch line shall be made with cement mortar 1:1 (1 cement: 1 fine sand). The exposed portion of the drop connection shall be encased all-around with minimum 15 cm thick concrete 1:5:10 (1 cement: 5 fine sand: 10 graded stone aggregate 40 mm nominal size) and cured. For encasing the concrete around the drop connection, the necessary centering and shuttering shall be provided. The holes made in the walls of the manhole shall be made good with brick work in cement mortar 1:4 (1 cement: 4 coarse sand) and plastered with cement mortar 1:3 (1 cement: 3 coarse sand) on the inside of the manhole wall. The excavated earth shall be back filled in the trench in level with the original ground level.

**19.5.3 Measurements**

Drop connection shall be enumerated. The depths beyond 60 cm shall be measured in running metres correct to a cm under relevant items.

**19.5.4 Rate**

The rate shall include the cost of labour and materials involved in all the operations described above but excluding the cost of excavations and refilling.

**19.6 OPEN SURFACE DRAIN (FIG. 19.12)**

The open drains shall be of the size, as specified in the item and laid to such gradients and in such locations as may be shown in the relevant drawing or as directed by the Engineer-in-Charge.

The size of the drain as specified shall be the width of the drain at the top, measured between the masonry walls. The drain shall be given, as far as possible, uniform slope from the starting point to the discharge point.

The average depths of the various sizes of drains shall be as follows:—

| <i>Drain size</i> | <i>Depth</i> |
|-------------------|--------------|
| 10 cm             | 20 cm        |
| 15 cm             | 20 cm        |
| 25 cm             | 30 cm        |

**19.6.1 Measurements**

The drains shall be measured in running metres, correct to a cm.

**19.6.2 Rate**

The rate shall include the cost of labour and materials required for all the operations described above, suitable deduction or extra payment, per cm basis shall be made in case there is a variation in average depths from those stated above.

**19.7 ROAD GULLY CHAMBER WITH GRATING**

**19.7.1 Road Gully Chamber with Horizontal Grating (Fig. 19.14)**

The chamber shall be of brick masonry of specified class and shall have a C.I. grating with frame fixed in 15 cm thick cement concrete 1:2:4 (1 cement: 2 coarse sand: 4 graded stone aggregate 20 mm nominal size) at the top. The size of the chamber shall be taken as the clear internal dimensions of the C.I. frame. The chamber shall have a connection pipe, the length of which in metre between the road gully chamber and the manhole of the drain shall not be less than one by forty (1/40) times the nominal diameter of pipe in mm (i.e. for 150 mm connection pipe, length shall not be less than 3.7 m and for 250 mm connection pipe length shall not be less than 6.25 m). The chamber shall be built at the location fixed by the Engineer-in-Charge. Generally the spacing of the chambers shall be 18 to 36 m depending upon the grading of the road channel and the area of the drainage. R.C.C. gully grating shall be fixed in cement mortar 1:2 (1 cement: 2 coarse sand) as shown in Fig. 19.13.

**19.7.2 Road Gully Chamber with Vertical Grating (Fig. 19.14)**

The chamber shall be of brick masonry 12 mm dia round bar shall be fixed in cement concrete block at the bottom. The bars at the top shall be welded or riveted to M.S. flat 40 × 6 mm as shown in Fig. 19.14. The specifications shall be same as described in 19.7.1.

### **19.7.3 Road Gully Chamber with Horizontal and Vertical Grating**

The details of typical road gully chamber of brick masonry shall be same as shown in Fig. 19.14.

### **19.7.4 Measurements**

Road gully chambers shall be enumerated.

### **19.7.5 Rate**

The rate shall include the cost of materials and labour involved in all the operations described above except the cost of excavation and connection pipes.

## **19.8 BRICK MASONRY GULLY TRAP (FIG. 19.2)**

The internal size of the trap shall be 80 × 40 × 46 cm. The height shall be measured from the top of the floor to the top of the cover. 40 mm thick stone baffles shall be fixed 50 mm deep in masonry with cement mortar 1:4 (1 cement: 4 fine sand), as shown in the Fig. 19.2. The connection of open surface, drain with a soak pit shall be invariably through a grease trap.

### **19.8.1 Measurements**

Grease traps shall be enumerated.

### **19.8.2 Rate**

The rate shall include the cost of labour and materials required for all the operations described above.

## **19.9 SEPTIC TANK (FIG. 19.15 & 19.16)**

In unsewered area, every house shall have arrangements for its sewage being treated in septic tank, effluent from which should be given secondary treatment either in a biological filter or on the land, or in a sub-surface disposal system.

Surface and sub-soil water should be excluded from finding way into the septic tank. Waste water may be passed into the septic tank provided the tank and the means for effluent disposal are designed to cope up with this extra liquid. Depending on the location of the water table and the nature of the strata, the type of disposal for the effluent from the septic tank shall be decided.

### **19.9.1 Dimensions**

Septic tanks shall have minimum width of 75 cm, minimum depth of one metre below water level and a minimum liquid capacity of the one cubic metre. Length of tanks shall be 2 to 4 times the width. Suitable sizes of septic tanks for use of 5, 10, 15, 20 and 50 persons based on certain assumptions are given in Appendix II.

### **19.9.2 Cover and Frame**

Every septic tank shall be provided with C.I. cover of adequate strength. The cover and frames shall be 500 mm dia. (M.D.) minimum or 610 mm × 455 mm (LD). The specification for frames and cover given in 19.3.1 shall apply.

### **19.9.3 Ventilating Pipe**

Every septic tank shall be provided with C.I. ventilating pipe of at least 50 mm diameter. The top of the pipe shall be provided with a suitable cage of mosquito proof wire mesh.

The ventilating pipe shall extend to a height which would cause no smell nuisance to any building in the area. Generally the ventilating pipe may extend to a height of about 2 m, when the septic tank is at least 15 m away from the nearest building and to a height of 2 m. above the top of the building when it is located closer than 15 metres. The ventilating pipe may also be connected to the normal soil ventilating system of the building where so desired.

#### **19.9.4 Disposal of Sludge**

The sludge from septic tanks may be delivered into covered pit or into a suitable vehicle for removal from the site. Spreading of sludge on the ground in the vicinity shall not be allowed.

#### **19.9.5 Testing**

Before the tank is commissioned for use, it shall be tested for water-tightness by filling it with water and allowing it to stand for 24 hours. It shall then be topped up, if necessary, and allowed to stand for a further period of 24 hours during which time the fall in the level of the water shall not be more than 1.5 cm.

#### **19.9.6 Commissioning of Septic Tank**

The tank shall be filled with water to its outlet level before the sewage is let into the tank. It shall, preferably, be seeded with small quantities of well digested sludge obtained from septic tanks or sludge digestion tanks. In the absence of digested sludge a small quantity of decaying organic matter, such as digested cow-dung, may be introduced.

#### **19.9.7 Sub-Surface Absorption System**

The effluent from septic tank shall be disposed of by soak pit or dispersion trench depending on the position of the sub-soil water level, soil and sub-soil conditions and the size of the installation.

#### **19.9.8 Measurements**

Septic tank shall be enumerated.

#### **19.9.9 Rate**

The rate shall include the cost of materials and labour involved in all the operation, except Sub-Surface absorption system which shall be paid for separately.

### **19.10 SOAK PITS 2.5 M DIA × 3 M DEEP (FIG. 19.17)**

#### **19.10.1 Construction**

The earth excavation shall be carried out to the exact dimensions as shown in the figure. In the soak pit shall be constructed a honey-comb dry brick shaft 45 x 45 cm and 292.5 cm high. Round the shaft and within the radius of 60 cm shall be placed well burnt brick bats. Brick ballast of size from 50 to 80 mm nominal size shall be packed round the brick bats up to the radius of 90 cm. The remaining portion shall be filled with brick ballast of 40 mm nominal size. The construction of shaft and filling of the bats and the ballast shall progress simultaneously.

#### **19.10.2 Cover and Drain**

Over the filling shall be placed single matting which shall be covered with minimum layer of 7.5 cm earth. The shaft shall be covered with 7.5 cm thick stone or R.C.C. slab 10 cm wide and 10 cm deep brick edging with bricks of class designation 75 shall be provided round the pit. The connection of the open surface drain to the soak pit shall be made by means of 100 mm diameter S.W. pipe with open joints.

#### **19.10.3 Measurements**

Soak pit shall be enumerated.

#### **19.10.4 Rate**

Rate shall include the cost of labour and material involved in all the operations described above.

## **19.11 SOAK PIT 1.2 × 1.2 × 1.2 M**

### **19.11.1 Construction**

The earth excavation shall conform to the general specifications for earth work. After the excavation is complete the soak pit shall be filled with brick bats. The brick bats shall be from properly burnt bricks. 10 cm wide and 10 cm deep brick edging with bricks of class designation 75 shall be provided round the soak pit.

### **19.11.2 Measurements**

Soak pits shall be enumerated.

### **19.11.3 Rate**

Rate shall include the cost of labour and materials involved in all the operations.

## **19.12 DISPERSION TRENCH (FIG. 19.18)**

It shall be provided when the sub-soil water level is within 180 cm from the ground level. Dispersion trenches are not recommended in areas where fibrous roots of trees or vegetation are likely to penetrate the system and cause blockages.

### **19.12.1 Construction**

Dispersion trenches shall be 50 to 100 cm deep and 30 to 100 cm wide, excavated to a slight gradient and shall be provided with 15 to 25 cm of washed gravel or crushed stones. Open jointed pipes placed inside the trench shall be made of unglazed earthenware clay or concrete and shall have minimum internal diameter of 75 to 100 mm. Each dispersion trench should not be longer than 30 m and trenches should not be placed closer than 1.8 m.

The covering for the pipes on the top shall be with coarse aggregate of uniform size to a depth of approximately 15 cm. The aggregate above this level may be graded with aggregate 12 to 15 mm to prevent ingress of top soil while the free flow of water is no way retarded. The trench may be covered with about 30 cm of ordinary soil to form a mound and turned over. The finished top surface may be kept at least 15 cm above ground level to prevent direct flooding of the trench during rains.

### **19.12.2 Measurements**

The length of dispersion trench shall be measured in running metres nearest to a cm.

### **19.12.3 Rate**

The rate shall include the cost of materials and labour involved in all the operations described above.

## **19.13 DESLUDGING OF SEPTIC TANKS**

Septic tanks shall be desludged periodically, the intervals of desludging, depending upon the design of the septic tanks and the capacity in relation to its users. Desludging may be done when the sludge level reaches a predetermined level. A portion of the sludge may be left in the tank to seed the fresh deposits.

Desludging shall preferably be carried out by hydrostatic head or by using a portable pump. Manual handling of sludge shall be discouraged.

## **19.14 DISMANTLING OF OLD S.W. PIPES**

The specification specified in clause 15.3.16 shall be applicable.

## **19.15 6 MM THICK PLASTIC ENCAPSULATED M.S. FOOT REST**

**19.15.1** All manholes deeper than 0.8 m shall be provided with foot rests. These shall be embedded 13.8 cm deep in 30x20x15 cm blocks of cement concrete 1:3:6 (1 cement: 3 coarse sand 6 graded stone aggregate 20 mm nominal size). The concrete block with foot rest placed in its centre shall be cast in situ along with the masonry and surface finished with 12 mm thick cement plaster 1:3 (1 cement: 3 coarse sand) finished smooth.

Foot rests which shall be of 6 mm thick plastic encapsulated as per IS:10910 on 12 mm dia steel bar as shown in Fig. 19.19 shall be fixed 40 cm apart vertically and staggered laterally and shall project 12.5 cm beyond the surface of the wall. The top foot rest shall be 45 cm below the manhole cover.

1. Minimum 6 mm thick Polypropylene and its copolymers conforming to IS-10910 shall be moulded around a 12 mm dia steel bar.
2. Overall minimum length shall be of 263 mm and width as 165 mm (U shape 691 mm) with minimum 112 mm space between protruded legs having a 2 mm tread on top surface by ribbing or chequering besides necessary and adequate anchoring projections on tail length of 138 mm as per standard drawing and suitable to with stand the bend test and chemical resistance test as per specifications and having manufacture's permanent identification mark to be visible even after fixing.

#### **19.15.2 Measurements**

The foot-rest shall be enumerated under the relevant item.

#### **19.15.3 Rate**

The rate shall include the cost of labour and material involved in all the operations described above.

#### **19.16 REPLACEMENT OF M.S. FOOT RESTS IN MANHOLES**

The specification specified in clause 19.4.6 shall be applicable.

#### **19.17 RAISING OF MANHOLE COVER AND FRAME SLAB**

##### **19.17.1 General**

##### **Removal of RCC Cover and frame**

Shall be removed carefully and stacked properly as per direction of Engineer-in-charge.

##### **Dismantling of RCC Slab**

Dismantling of RCC slab shall conform to the specifications described in para 15.3.11.

##### **Brick Works**

Brick work shall conform to the specifications described in para 19.4.3

##### **Plaster and pointing**

Plaster and pointing shall conform to the specifications described in para 19.4.4.

##### **Frame Work (centering & shuttering)**

Frame Work (centering & shuttering) shall conform to the specifications described in para 5.2

##### **RCC Work**

RCC Work shall conform to the specifications described in para 5.4

##### **Placing of Covers and Frames**

Placing of Covers and Frames shall conform to the specifications described in para 19.4.7.

#### **19.17.2 Measurements**

Raising of Manhole shall be enumerated under relevant items.

#### **19.17.3 Rate**

The rate shall include the cost of materials and labour involved in all the operations described above but excludes the cost of (i) Reinforcement and (ii) The raising depth of the manhole to be paid separately.

### **19.18 INSPECTION CHAMBER (FIG.19.20 to 19.22 )**

**19.18.1** At every change of alignment, gradient or diameter of drain, there shall be an inspection chamber. Bends and junctions in the drain shall be grouped together in an inspection chamber as far as possible. The maximum distance between chambers shall be 30m.

Inspection chambers of different types and sizes as specified shall be constructed in the drainage line at such places and to such levels and dimensions as shown in the drawings or as directed by the Engineer-in Charge. The size specified shall indicate the inside dimensions between brick faces of the inspection chamber.

Where the diameter of the drain is increased, the crown of the pipe shall be fixed at the same level and necessary slope given in the invert of the inspection chamber. In exceptional cases and where unavoidable, the crown of the branch drainage may be fixed at a lower level but in such cases the peak flow level of the two drainages shall be kept the same.

Drainage of unequal sectional area shall not be jointed at the same invert in an inspection chamber. The invert of the smaller drainage at its junction with main shall be at least 2/3 the diameter of the main above the invert of the main. The branch drainage shall deliver drainage in the inspection chamber in the direction of main flow and the junction must be made with care so that flow in main is not impeded.

Inspection chamber of 455 × 610 mm and 45 cm deep for single pipe line, 500 × 700 mm and 45 cm deep for one or two inlets and 600 × 850 mm and 45 cm deep for three or more inlets are generally constructed for drainage line.

#### **19.18.2 Excavation**

The excavation for inspection chamber shall be true to dimensions and levels shown on the plans or as directed by the Engineer-in-Charge.

#### **19.18.3 Bed Concrete**

The inspection chambers shall be built on a bed of cement concrete 1:5:10 (1 cement: 5 coarse sand: 10 graded stone aggregate 40 mm nominal size) unless required by local authorities. The thickness of the bed concrete shall be 15 cm unless otherwise specified or directed by the Engineer-in-Charge and 40 mm thick cement concrete 1:2:4 (1 cement: 4 coarse sand: 4 grade stone aggregate 40 mm nominal size).

#### **19.18.4 Brick Work**

The brick work shall be with class 75 bricks in one brick thickness in cement mortar 1:4 (1 cement: 4 coarse sand). The external joints of the brick masonry shall be finished smooth, and the joints of the pipes with the masonry shall be made perfectly leak proof.

#### **19.18.5 Plaster and Pointing**

The walls of the inspection chambers shall be plastered inside including bed with 12 mm thick cement plaster 1:3 (1 cement: 3 coarse sand) finished smooth.

For earth work excavation, bed concrete, brick work, plaster and pointing, R.C.C. work and refilling of earth, respective specifications shall be followed.

#### **19.18.6 Inspection Chamber Covers and Frames**

The frame of inspection chambers shall be firmly embedded to correct alignment and levels in R.C.C. slab or plain concrete as the case may be on the top of the masonry. After completion of the work, inspection chamber covers shall be sealed by means of thick grease.

### 19.18.7 Measurements

Inspection chambers shall be enumerated under relevant items. The depth of the inspection chambers shall be reckoned from the top level of C.I. cover to the invert level. The depth shall be measured correct to a cm. The extra depth shall be measured and paid as extra over the specified depth.

### 19.18.8 Rate

The rate shall include the cost of materials and labour involved in all the operations described above but excludes the cost of (i) excavation, (ii) 12 mm thick cement plaster with water proofing material applied at the external surface of the inspection chambers if required (iii) 40 mm thick cement concrete 1:2:4 (1 cement: 2 coarse sand: 4 grade stone aggregate 40 mm nominal size). These items shall be paid for separately under relevant items of work. Payment for extra depths of inspection chambers shall be made separately under relevant items of work.

### 19.19. NON PRESSURE NP-3 CLASS (MEDIUM DUTY)/ NP-4 CLASS (HEAVY DUTY) R.C.C. PIPES

**19.19.1** The pipes shall be with reinforcement as required and shall be of class not lesser than NP2. These shall conform to IS 458 and shall be capable of withstanding a test pressure of 0.07 MPa (7 m head). The reinforced cement concrete pipes shall be manufactured by centrifugal (or spun) process or vibrated casting process. All pipes shall be true to shape, straight, perfectly sound and free from cracks and flaws. The external and internal surface of the pipes shall be smooth and hard. The pipes shall be free from defects resulting from imperfect grading of the aggregate mixing or moulding.

Concrete used for the manufacture of reinforced concrete pipes and collars shall be as per design mix. The concrete quality (concrete mix, maximum water-cement ratio, minimum cement content. etc) shall be as per IS 456 for at least very severe environment exposure condition with minimum cement content 260 kg/m<sup>3</sup>. The maximum size of aggregate should not exceed one third of the thickness of the pipe or 20 mm whichever is smaller for pipes above 250 mm internal diameter. But for pipes of internal diameter 80 to 250 mm, the maximum size of aggregate should be 10mm. The reinforcement in the reinforced concrete pipes shall extend throughout the length of the pipe. The circumferential and longitudinal reinforcements shall be adequate to withstand the specified hydrostatic pressure and further bending stresses due to the weight of water when running full across a span equal to the length of pipe plus three times its own weight.

The **Design/** dimensional requirements of concrete pipes are given in Appendix I A (collar for NP2 pipe) and I B (for NP-2 pipe), Appendix I C (Collar for NP-3 & NP-4 pipe ), Appendix I D and 1 E (for NP-3 pipe), Appendix I F and I G (for NP-4 pipe).

The minimum clear cover for reinforcement in pipes and collars shall be as given in Table 19.6.

**TABLE 19.6**

| Sl . No. | Precast concrete pipe/collar | Minimum clear cover, mm |
|----------|------------------------------|-------------------------|
| (i)      | Barrel wall thickness        |                         |
|          | (a) Upto and including 75 mm | 8                       |
|          | (b) Over 75 mm               | 15                      |
| (ii)     | At spigot steps              | 5                       |
| (iii)    | At end of longitudinal       | 5                       |

**Note :** An effective means shall be provided for maintaining the reinforcement in position and for ensuring correct cover during manufacture of the unit. Spacers for this purpose shall be of rust proof material or of steel protected against corrosion.



## **19.19.2 Laying and Jointing Cement Concrete Pipes and Specials**

### **19.19.2.1 Trenches:**

- (i) Trenches shall be as described in 18.4.4. Where the pipes are to be bedded directly on soil, the bed shall be suitably rounded to fit the lower part of the pipe, the cost for this operation being included in the rate for laying the pipe itself.
- (ii) Loading, transporting and unloading of concrete pipes shall be done with care. Handling shall be such as to avoid impact. Gradual unloading by inclined plane or by chain pulley block is recommended. All pipe sections and connections shall be inspected carefully before being laid. Broken or defective pipes or connections shall not be used. Pipes shall be lowered into the trenches carefully. Mechanical appliances may be used. Pipes shall be laid true to line and grade as specified. Laying of pipes shall proceed upgrade of a slope.
- (iii) If the pipes have spigot and socket joints, the socket ends shall face upstream. In the case of pipes with joints to be made with loose collars, the collars shall be slipped on before the next pipe is laid. Adequate and proper expansion joints shall be provided where directed.
- (iv) In case where foundation conditions are unusual such as in the proximity of trees or holes, under existing or proposed tracks manholes etc. the pipe shall be encased all-around in 15 cm thick cement concrete 1:5:10 (1 cement : 5 fine sand : 10 graded stone aggregate 40 mm nominal size) or compacted sand or gravel.
- (v) In cases where the natural foundation is inadequate the pipes shall be laid either in concrete cradle supported on proper foundations or on any other suitably designed structure. If a concrete cradle bedding is used the depth of concrete below the bottom of the pipe shall be at least 1/4th of the internal dia of the pipe subject to the min. of 10 cm and a maximum of 30 cm. The concrete shall extend up the sides of the pipe at least to a distance of 1/4th of the outside diameter of pipes 300 mm and over in dia. The pipe shall be laid in this concrete bedding before the concrete has set. Pipes laid in trenches in earth shall be bedded evenly and firmly and as far up the haunches of the pipe as to safely transmit the load expected from the backfill through the pipe to the bed. This shall be done either by excavating the bottom of the trench to fit the curve of the pipe or by compacting the earth under around the curve of the pipe to form an even bed. Necessary provision shall be made for joints wherever required.
- (vi) When the pipe is laid in a trench in rock hard clay, shale or other hard material the space below the pipe shall be excavated and replaced with an equalising bed of concrete, sand or compacted earth. In no place shall pipe be laid directly on such hard material.
- (vii) The method of bedding and laying the pipes under different conditions are illustrated in Fig. 19.9.
- (viii) When the pipes are laid completely above the ground the foundations shall be made even and sufficiently compacted to support the pipe line without any material settlement. Alternatively the pipe line shall be supported on rigid foundations at intervals. Suitable arrangements shall be made to retain the pipe line in the proper alignment, such as by shaping the top of the supports to fit the lower part of the pipe. The distance between the supports shall in no case exceed the length of the pipe. The pipe shall be supported as far as possible close to the joints. In no case shall the joints come in the centre of the span. Care shall be taken to see that super imposed loads greater than the total load equivalent to the weight of the pipe when running full shall not be permitted. Suitably designed anchor blocks at change of direction and grades for pressure lines shall be provided where required.



### 19.19.2.2 Jointing:

Joints are generally of rigid type. Where specified flexible type joints may also be provided.

- (a) Rigid Spigot and Socket Joint (Fig. 19.10): The spigot of each pipe shall be slipped home well into the socket of the pipe previously laid and adjusted in the correct position. The opening of the joint shall be filled with stiff mixture of cement mortar in the proportion of 1:2 (1 cement: 2 fine sand) which shall be rammed with caulking tool. After a day's work any extraneous material shall be removed from the inside of the pipe and the newly made joint shall be cured.
- (b) Rigid Collar Joint (Fig. 19.10): The two adjoining pipes shall be butted against each other and adjusted in correct position. The collar shall then be slipped over the joint, covering equally both the pipes. The annular space shall be filled with stiff mixture of cement mortar 1:2 (1 cement: 2 fine sand) which shall be rammed with caulking tool. After a day's work any extraneous materials shall be removed from the inside of the pipe and the newly made joint shall be cured.
- (c) Semi Flexible Spigot and Socket Joint (Fig. 19.10): The joint is composed of specially shaped spigot and socket ends on the concrete pipes. A rubber ring shall be placed on the spigot which shall be forced into the socket of the pipe previously laid. This compresses the rubber ring as it rolls into the annular space formed between the two surfaces of the spigot and the socket, stiff mixture of cement mortar 1:2 (1 cement: 2 fine sand) shall then be filled into the remaining annular space and rammed with a caulking tool. After day's work any extraneous materials shall be removed from the inside of the pipe and the newly made joint shall be cured.
- (d) Semi Flexible Collar Joint: This is made up of a loose collar which covers two specially shaped pipe ends as shown in the Fig. 19.10. Each end shall be fitted with a rubber ring which when compressed between the spigot and the collar, seal the joint. Stiff mixture of cement mortar 1:2 (1 cement: 2 fine sand), shall then be filled into the remaining annular space and rammed with a caulking tool. After day's work, any extraneous material shall be removed from the inside of the pipe and the newly made joint shall be cured.
- (e) Internal Flush Joint (Fig. 19.10): This joint is generally used for culvert pipe of 60 cm dia and over. The ends of the pipe are specially shaped to form a self centering joint with an internal jointing space 1.3 cm wide the finished joint is flush with both inside and outside with the pipe wall as shown in Fig. 19.10. The jointing space is filled with cement mortar 1:2 (1 cement: 2 fine sand) mixed sufficiently dry to remain in position when forced with a trowel or rammer. After day's work, any extraneous material shall be removed from the inside of the pipe and the newly made joint shall be cured.
- (f) External Flush Joint : This joint is suitable for pipes which are too small for jointing from inside. This joint is composed of specially shaped pipe ends as shown in Fig. 19.10. Each end shall be butted against each other and adjusted in correct position. The jointing space shall then be filled with cement mortar 1:2 (1 cement: 2 fine sand) sufficiently dry and finished off flush. Great care shall be taken to ensure that the projecting ends are not damaged as no repairs can be readily affected from inside the pipe.

**19.19.2.3** In all pressure pipe lines the recess at the end of the pipe line shall be filled with jute braiding dipped in hot bitumen or other suitable approved compound. Pipes shall be so jointed that the bitumen ring of one pipe shall set into the recess of the next pipe. The ring shall be thoroughly compressed by jacking or by any other suitable method.

The number of pipes that shall be jacked together at a time shall depend on the diameter of the pipes and the bearing capacity of the soil, for small pipes up to 25 cm diameter, six pipes can be jacked together at a time.

The quantity of jute and bitumen in the ring shall be just sufficient to fill the recess in the pipe when pressed hard by jacking or by any other suitable method. Before and during jacking care shall be taken to see that there is no offset at the joint.

**19.19.2.4 Testing:** For pressure pipes, the completed pipeline shall be tested for pressure (Known as site test pressure) which shall not be less than the maximum pipeline operating pressure plus the calculated surge pressure, but in no case shall it exceed the hydrostatic test pressure. For non pressure pipes the joints shall be tested as per procedure laid down under Para 19.2.1.2 (iv).

**19.19.2.5 Refilling of Trenches:**

The specification described in 19.2.1.2 (v) shall apply. In case where pipes are not bedded on concrete special care shall be taken in refilling, trenches to prevent the displacement and subsequent settlement at the surface resulting in uneven street surfaces and dangers to foundations etc. The backfilling materials shall be packed by hand under and around the pipe and rammed with a shovel and light tamper. This method of filling will be continued up to the top of pipe. The refilling shall rise evenly on both sides of the pipe and continued up to 60 cm above the top of pipe so as not to disturb the pipe. No tamping shall be done within 15 cm of the top of pipe. The tamping shall become progressively heavier as the depth of the backfill increases.

**19.19.3 Measurements**

The lengths of pipes shall be measured in running metres nearest to a cm as laid or fixed, from inside of one manhole to the inside of the other manhole. The length shall be taken along the centre line of the pipes over all fittings such as bends, collars, junctions, etc. which shall not be measured separately.

Excavation, refilling, shoring and timbering in trenches, and cement concreting wherever required shall be measured separately under relevant items of work.

**19.19.4 Rate:**

The rate shall include the cost of materials and labour involved in all the operations described above.

**A: DIMENSIONAL REQUIREMENT OF CLASS NP2-REINFORCED CONCRETE LIGHT DUTY,  
NON PRESSURE PIPES & COLLAR  
(Clause 19.2.2)**

| Nominal<br>Internal<br>Diameter<br>of Pipe | Barrel Wall<br>Thickness<br>of pipe | Collar Dimensions            |                      |                   | Reinforcements in Collar                           |                     |                               |
|--|-------------------------------------|------------------------------|----------------------|-------------------|--|---------------------|-------------------------------|
|  |                                     | Minimum<br>Caulking<br>Space | Minimum<br>Thickness | Minimum<br>Length | Longitudinal, Mild<br>steel or Hard Drawn<br>Steel |                     | Spiral Hard<br>Drawn<br>Steel |
|  |                                     |                              |                      |                   | Minimum<br>Number                                  | Weight<br>Kg/Collar |                               |
| mm   | mm                                  | mm                           | mm                   | mm                | (6)  | (7)                 | (8)                           |
| (1)  | (2)                                 | (3)                          | (4)                  | (5)               | (6)  | (7)                 | (8)                           |
| 80   | 25                                  | 13                           | 25                   | 150               | 6  | 0.08                | 0.07                          |
| 100  | 25                                  | 13                           | 25                   | 150               | 6  | 0.08                | 0.08                          |
| 150  | 25                                  | 13                           | 25                   | 150               | 6  | 0.08                | 0.10                          |
| 200  | 25                                  | 13                           | 25                   | 150               | 6  | 0.08                | 0.12                          |
| 225  | 25                                  | 13                           | 25                   | 150               | 6  | 0.08                | 0.14                          |
| 250  | 25                                  | 13                           | 25                   | 150               | 6  | 0.08                | 0.16                          |
| 300  | 30                                  | 16                           | 30                   | 150               | 8  | 0.11                | 0.22                          |
| 350  | 32                                  | 16                           | 32                   | 150               | 8  | 0.11                | 0.25                          |
| 400  | 32                                  | 16                           | 32                   | 150               | 8  | 0.11                | 0.27                          |
| 450  | 35                                  | 19                           | 35                   | 200               | 8  | 0.15                | 0.40                          |
| 500  | 35                                  | 19                           | 35                   | 200               | 8  | 0.15                | 0.60                          |
| 600  | 45                                  | 19                           | 40                   | 200               | 8  | 0.15                | 0.70                          |
| 700  | 50                                  | 19                           | 40                   | 200               | 8  | 0.23                | 1.05                          |
| 800  | 50                                  | 19                           | 45                   | 200               | 8  | 0.23                | 1.85                          |
| 900  | 55                                  | 19                           | 50                   | 200               | 8  | 0.23                | 2.05                          |
| 1000                                       | 60                                  | 19                           | 55                   | 200               | 8  | 0.33                | 2.25                          |
| 1100                                       | 65                                  | 19                           | 60                   | 200               | 8  | 0.33                | 3.09                          |
| 1200                                       | 70                                  | 19                           | 65                   | 200               | 8  | 0.33                | 4.11                          |
| 1400                                       | 75                                  | 19                           | 75                   | 200               | 12   | 0.50                | 5.08                          |
| 1600                                       | 80                                  | 19                           | 80                   | 200               | 12 or 8+8  | 0.67                | 6.55                          |
| 1800                                       | 90                                  | 19                           | 90                   | 200               | 12 or 8+8  | 0.67                | 9.00                          |
| 2000                                       | 100                                 | 19                           | 100                  | 200               | 12+12  | 1.00                | 12.15                         |
| 2200                                       | 110                                 | 19                           | 110                  | 200               | 12+12  | 1.00                | 13.30                         |

**Note:**

1. If the mild steel is used for spiral reinforcement, the weight specified under col. 7 shall be increased by a factor 140/25.
2. Soft grade mild steel wire may be used as reinforcement for collars of pipes of nominal internal diameter up to 250 mm only, by increasing the weight by a factor 140/84. Where only soft grade mild steel wire is used for making collar cages, the weight of reinforcement shall be total weight or col. 6 and 7 multiplied by 140/84. This is allowed as a process requirement.
3. Internal diameter of collar to suit the actual diameter of pipes with minimum caulking space as given in col. 2

**B: REINFORCED CONCRETE PRESSURE PIPES CLASS P1 TESTED TO 20 m HEAD, CLASS P2 TESTED TO 40 m HEAD AND CLASS P3 TESTED TO 60 m HEAD**

| Internal diameter<br>of pipes<br>(mm) | Barrel dimension        |                         |                         |
|---------------------------------------|-------------------------|-------------------------|-------------------------|
|                                       | <i>Class P1</i><br>(mm) | <i>Class P2</i><br>(mm) | <i>Class P3</i><br>(mm) |
| 80                                    | 25                      | 25                      | 25                      |
| 100                                   | 25                      | 25                      | 25                      |
| 150                                   | 25                      | 25                      | 25                      |
| 200                                   | 25                      | 30                      | 35                      |
| 225                                   | 25                      | 30                      | 35                      |
| 250                                   | 25                      | 30                      | 35                      |
| 300                                   | 30                      | 40                      | 45                      |
| 350                                   | 32                      | 45                      | 55                      |
| 400                                   | 32                      | 50                      | 60                      |
| 450                                   | 35                      | 50                      | 70                      |
| 500                                   | 35                      | 55                      | 75                      |
| 600                                   | 40                      | 65                      | 90                      |
| 700                                   | 40                      | 70                      | 105                     |
| 800                                   | 45                      | 80                      | 120                     |
| 900                                   | 50                      | 90                      | -                       |
| 1000                                  | 55                      | 100                     | -                       |
| 1100                                  | 60                      | -                       | -                       |
| 1200                                  | 65                      | -                       | -                       |

**Notes :**

1. The effective length of barrel shall be 2 m up to 250 mm nominal diameter pipes and 2.5, 3.0, 3.5 or 4.0 m for pipes above 250 mm.
2. Collar dimensions will be same as specified for class NP2 pipes.

**C: Table 21 DESIGN REQUIREMENT OF REINFORCED CONCRETE COLLAR FOR PIPE OF CLASS NP-2 (Clause 19.19)**

*( Clause 6.3 and 8.1 of IS 458:2003)*

| Nominal Internal Diameter of Pipe | Collar Dimensions      |                   |                | Reinforcements in Collar                     |                     |                         |
|-----------------------------------|------------------------|-------------------|----------------|--|---------------------|-------------------------|
|                                   | Minimum Caulking Space | Minimum Thickness | Minimum Length | Longitudinal, Mild steel or Hard Drawn Steel |                     | Spiral Hard Drawn Steel |
| mm                                | mm                     | mm                | mm             | Minimum Number                               | Weight<br>Kg/Collar | Kg/Collar               |
| (1)                               | (3)                    | (4)               | (5)            | (6)  | (7)                 | (8)                     |
| 80                                | 13                     | 25                | 150            | 6  | 0.08                | 0.07                    |
| 100                               | 13                     | 25                | 150            | 6  | 0.08                | 0.08                    |
| 150                               | 13                     | 25                | 150            | 6  | 0.08                | 0.10                    |
| 200                               | 13                     | 25                | 150            | 6  | 0.08                | 0.12                    |
| 225                               | 13                     | 25                | 150            | 6  | 0.08                | 0.14                    |
| 250                               | 13                     | 25                | 150            | 6  | 0.08                | 0.16                    |
| 300                               | 16                     | 30                | 150            | 8  | 0.11                | 0.22                    |
| 350                               | 16                     | 32                | 150            | 8  | 0.11                | 0.25                    |
| 400                               | 16                     | 32                | 150            | 8  | 0.11                | 0.27                    |
| 450                               | 19                     | 35                | 200            | 8  | 0.15                | 0.40                    |
| 500                               | 19                     | 35                | 200            | 8  | 0.15                | 0.60                    |
| 600                               | 19                     | 40                | 200            | 8  | 0.15                | 0.70                    |
| 700                               | 19                     | 40                | 200            | 8  | 0.23                | 1.05                    |
| 800                               | 19                     | 45                | 200            | 8  | 0.23                | 1.85                    |
| 900                               | 19                     | 50                | 200            | 8  | 0.23                | 2.05                    |
| 1000                              | 19                     | 55                | 200            | 8  | 0.33                | 2.25                    |
| 1100                              | 19                     | 60                | 200            | 8  | 0.33                | 3.09                    |
| 1200                              | 19                     | 65                | 200            | 8  | 0.33                | 4.11                    |
| 1400                              | 19                     | 75                | 200            | 12   | 0.50                | 5.08                    |
| 1600                              | 19                     | 80                | 200            | 12 or 8+8                                    | 0.67                | 6.55                    |
| 1800                              | 19                     | 90                | 200            | 12 or 8+8                                    | 0.67                | 9.00                    |
| 2000                              | 19                     | 100               | 200            | 12+12  | 1.00                | 12.15                   |
| 2200                              | 19                     | 110               | 200            | 12+12  | 1.00                | 13.30                   |

**Note:**

1. If the mild steel is used for spiral reinforcement, the weight specified under col. 7 shall be increased by a factor 140/125.
2. Soft grade mild steel wire may be used as reinforcement for collars of pipes of nominal internal diameter up to 250 mm only, by increasing the weight by a factor 140/84. Where only soft grade mild steel wire is used for making collar cages, the weight of reinforcement shall be total weight or col. 6 and 7 multiplied by 140/84. This is allowed as a process requirement.
3. Internal diameter of collar to suit the actual diameter of pipes with minimum caulking space as given in col. 2

**D: Table 2 Design and Strength Test Requirements of Concrete Pipes of Class NP2-Reinforced Concrete, Light Duty, Non-pressure Pipes (Clause 19.19)****(Clauses 6.1.1, 6.1.2.1, 6.1.3, 6.2.2, 7.3.2, 8.1 and Table 20 of IS 458:2003)**

| Internal Diameter of Pipes | Barred wall Thickness | Reinforcements                               |                 |                         | Strength Test requirements for Three Edge Bearing Test. |                 |
|----------------------------|-----------------------|--|-----------------|-------------------------|---|-----------------|
|                            |                       | Longitudinal, Mild Steel or Hard Drawn Steel |                 | Spiral Hard Drawn Steel | Load to Produce 0.25 mm Crack                           | Ultimate Load   |
| mm                         | mm                    | Minimum Number                               | Kg/linear metre | kg/linear metre         | kN/linear metre   | kN/linear metre |
| (1)                        | (2)                   | (3)  | (4)             | (5)                     | (6)   | (7)             |
| 80                         | 25                    | 6  | 0.59            | 0.16                    | 10.05   | 15.08           |
| 100                        | 25                    | 6  | 0.59            | 0.18                    | 10.05   | 15.08           |
| 150                        | 25                    | 6  | 0.59            | 0.24                    | 10.79   | 16.19           |
| 200                        | 25                    | 6  | 0.59            | 0.38                    | 11.77   | 17.66           |
| 225                        | 25                    | 6  | 0.59            | 0.46                    | 12.26   | 18.39           |
| 250                        | 25                    | 6  | 0.59            | 0.58                    | 12.55   | 18.83           |
| 300                        | 30                    | 8  | 0.78            | 0.79                    | 13.48   | 20.22           |
| 350                        | 32                    | 8  | 0.78            | 1.13                    | 14.46   | 21.69           |
| 400                        | 32                    | 8  | 0.78            | 1.49                    | 15.45   | 23.18           |
| 450                        | 35                    | 8  | 0.78            | 1.97                    | 16.18   | 24.27           |
| 500                        | 35                    | 8  | 0.78            | 2.46                    | 17.16   | 25.74           |
| 600                        | 45                    | 8  | 0.78            | 3.47                    | 18.88   | 28.32           |
| 700                        | 50                    | 8  | 1.22            | 4.60                    | 20.35   | 30.53           |
| 800                        | 50                    | 8  | 1.22            | 6.71                    | 21.57   | 32.36           |
| 900                        | 55                    | 8  | 1.22            | 9.25                    | 22.80   | 34.20           |
| 1000                       | 60                    | 8  | 1.76            | 10.69                   | 24.27   | 36.41           |
| 1100                       | 65                    | 8  | 1.76            | 12.74                   | 25.50   | 38.25           |
| 1200                       | 70                    | 8  | 1.76            | 15.47                   | 26.97   | 40.46           |
| 1400                       | 75                    | 12   | 2.64            | 20.57                   | 29.42   | 44.13           |
| 1600                       | 80                    | 12 or 8+8                                    | 3.52            | 25.40                   | 32.12   | 48.18           |
| 1800                       | 90                    | 12 or 8+8                                    | 3.52            | 32.74                   | 35.06   | 52.59           |
| 2000                       | 100                   | 12+12  | 5.28            | 45.14                   | 37.76   | 56.64           |
| 2200                       | 110                   | 12+12  | 5.28            | 56.37                   | 40.21   | 60.32           |

**NOTES**

1. If mild steel is used for spiral reinforcement, the weight specified under col. 5 shall be increased to 140/125.
2. Soft grade mild steel wire for spirals may be used for pipes of internal diameters 80 mm, 100 mm and 150 mm only by increasing weight to 140/84.
3. The longitudinal reinforcement given in this table is valid for pipes up to 25m effective length for internal diameter of pipe up to 250mm up to 3m effective length for higher diameter pipe.
4. Total mass of longitudinal reinforcement shall be calculated by multiplying the values given in col. 4 by the length of the pipe and then deducting for the cover length provided at the two ends.

E: Table 22 Design Requirements of Reinforced Concrete Collars for Pipes of Class NP3 and NP4

(Clauses 6.3 and 8.1 of IS 458:2003)

| Nominal Internal Diameter of pipe | Collar Dimensions      |                   |                | Reinforcements                               |                  |                         |
|-----------------------------------|------------------------|-------------------|----------------|--|------------------|-------------------------|
|                                   | Minimum caulking Space | Minimum Thickness | Minimum Length | Longitudinal, Mild Steel or Hard Drawn Steel |                  | Spiral Hard Drawn Steel |
| mm<br>(1)                         | mm<br>(2)              | mm<br>(3)         | mm<br>(4)      | Nos<br>(5)                                   | Kg/collar<br>(6) | Kg/collar<br>(7)        |
| 90                                | 13                     | 25                | 150            | 6  | 0.08             | 0.07                    |
| 100                               | 13                     | 25                | 150            | 6  | 0.08             | 0.08                    |
| 150                               | 13                     | 25                | 150            | 6  | 0.08             | 0.10                    |
| 200                               | 13                     | 25                | 150            | 6  | 0.08             | 0.12                    |
| 225                               | 13                     | 25                | 150            | 6  | 0.08             | 0.14                    |
| 250                               | 13                     | 25                | 150            | 6  | 0.08             | 0.16                    |
| 300                               | 16                     | 30                | 150            | 8  | 0.11             | 0.22                    |
| 350                               | 19                     | 35                | 200            | 8  | 0.15             | 0.40                    |
| 400                               | 19                     | 35                | 200            | 8  | 0.15             | 0.50                    |
| 450                               | 19                     | 35                | 200            | 8  | 0.15             | 0.60                    |
| 500                               | 19                     | 40                | 200            | 8  | 0.15             | 0.70                    |
| 600                               | 19                     | 40                | 200            | 8  | 0.23             | 1.05                    |
| 700                               | 19                     | 45                | 200            | 8  | 0.23             | 1.85                    |
| 800                               | 19                     | 50                | 200            | 8  | 0.23             | 2.05                    |
| 900                               | 19                     | 55                | 200            | 8  | 0.33             | 2.25                    |
| 1000                              | 19                     | 60                | 200            | 8  | 0.33             | 3.09                    |
| 1100                              | 19                     | 65                | 200            | 8  | 0.33             | 4.11                    |
| 1200                              | 19                     | 75                | 200            | 12   | 0.50             | 5.08                    |
| 1400                              | 19                     | 80                | 200            | 12 or 8+8                                    | 0.67             | 6.55                    |
| 1600                              | 19                     | 90                | 200            | 12 or 8+8                                    | 0.67             | 9.00                    |
| 1800                              | 19                     | 100               | 200            | 12 +12                                       | 1.00             | 12.15                   |
| 2000                              | 19                     | 110               | 200            | 12 +12                                       | 1.00             | 13.30                   |

**F: Table 3 Design and Strength Test Requirements of Concrete Pipes of Class NP3-Reinforced Concrete, Medium Duty, Non-pressure Pipes**

(Clauses 6.1.1, 6.1.2, 6.1.3, 6.2.2, 7.3.2, 8.1 and Table 20 of IS 458:2003)

| Internal Diameter of Pipes | Barred wall Thickness | Reinforcements                               |                 |                         | Strength Test requirements for Three Edge Bearing Test. |                 |
|----------------------------|-----------------------|--|-----------------|-------------------------|---|-----------------|
|                            |                       | Longitudinal, Mild Steel or Hard Drawn Steel |                 | Spiral Hard Drawn Steel | Load to Produce 0.25 mm Crack                           | Ultimate Load   |
| mm                         | mm                    | Minimum Number                               | kg/linear metre | kg/linear metre         | kN/linear metre   | kN/linear metre |
| (1)                        | (2)                   | (3)  | (4)             | (5)                     | (6)   | (7)             |
| 80                         | 25                    | 6  | 0.59            | 0.16                    | 13.00   | 19.50           |
| 100                        | 25                    | 6  | 0.59            | 0.22                    | 13.00   | 19.50           |
| 150                        | 25                    | 6  | 0.59            | 0.46                    | 13.70   | 20.55           |
| 200                        | 30                    | 6  | 0.59            | 0.81                    | 14.50   | 21.75           |
| 225                        | 30                    | 6  | 0.59            | 1.03                    | 14.80   | 22.20           |
| 250                        | 30                    | 6  | 0.59            | 1.24                    | 15.00   | 22.50           |
| 300                        | 40                    | 8  | 0.78            | 1.80                    | 15.50   | 23.25           |
| 350                        | 75                    | 8  | 0.78            | 2.95                    | 16.77   | 25.16           |
| 400                        | 75                    | 8  | 0.78            | 3.30                    | 19.16   | 28.74           |
| 450                        | 75                    | 8  | 0.78            | 3.79                    | 21.56   | 32.34           |
| 500                        | 75                    | 8  | 0.78            | 4.82                    | 23.95   | 35.93           |
| 600                        | 85                    | 8 or 6+6                                     | 1.18            | 7.01                    | 28.74   | 43.11           |
| 700                        | 85                    | 8 or 6+6                                     | 1.18            | 10.27                   | 33.53   | 50.30           |
| 800                        | 95                    | 8 or 6+6                                     | 2.66            | 13.04                   | 38.32   | 57.48           |
| 900                        | 100                   | 6+6  | 2.66            | 18.30                   | 43.11   | 64.67           |
| 1000                       | 115                   | 6+6  | 2.66            | 21.52                   | 47.90   | 71.85           |
| 1100                       | 115                   | 6+6  | 2.66            | 27.99                   | 52.69   | 79.00           |
| 1200                       | 120                   | 8+8  | 3.55            | 33.57                   | 57.48   | 86.22           |
| 1400                       | 135                   | 8+8  | 3.55            | 46.21                   | 67.06   | 100.60          |
| 1600                       | 140                   | 8+8  | 3.55            | 65.40                   | 76.64   | 114.96          |
| 1800                       | 150                   | 12+12  | 9.36            | 87.10                   | 86.22   | 129.33          |
| 2000                       | 170                   | 12+12  | 9.36            | 97.90                   | 95.80   | 143.70          |
| 2200                       | 185                   | 12+12  | 9.36            | 133.30                  | 105.38  | 158.07          |
| 2400                       | 200                   | 12+12  | 14.88           | 146.61                  | 114.96  | 172.44          |
| 2600                       | 215                   | 12+12  | 14.88           | 175.76                  | 124.54  | 186.81          |

**NOTES**

1. If mild steel is used for spiral reinforcement, the weight specified under col 5 shall be increased to 140/125.
2. The longitudinal reinforcement given in this table is valid for pipes up to 25m effective length for internal diameter of pipe up to 250 mm and up to 3m effective length for higher diameter pipes.
3. Total mass of longitudinal reinforcement Shall be calculated by multiplying the values given in col 4 by the length of the pipe and then deducting for the cover length provided at the two ends.
4. Concrete for pipes shall have a minimum compressive strength of 35 N/mm<sup>2</sup> at 28 days



**G: Table 5 Design and Strength Test Requirements of Concrete Pipes of Class NP3-Reinforced Concrete, Medium Duty, Non-pressure Pipes made by Vibrated Casting Process**

(Clauses 5.5.1, 6.1.1, 6.1.2.1, 6.1.3, 6.2.2, 7.3.2, 8.1 and Table 20 of IS 458:2003)

| Internal Diameter of Pipes | Minimum Barred Thickness | Reinforcements                               |                 |                         | Strength Test requirements for Three Edge Bearing Test. |                 |
|----------------------------|--------------------------|--|-----------------|-------------------------|---|-----------------|
|                            |                          | Longitudinal, Mild Steel or Hard Drawn Steel |                 | Spiral Hard Drawn Steel | Load to Produce 0.25 mm Crack                           | Ultimate Load   |
| mm                         | mm                       | Minimum Number                               | Kg/linear metre | kg/linear metre         | kN/linear metre   | kN/linear metre |
| (1)                        | (2)                      | (3)  | (4)             | (5)                     | (6)   | (7)             |
| 300                        | 50                       | 8  | 0.78            | 1.53                    | 15.50   | 23.25           |
| 350                        | 55                       | 8  | 0.78            | 1.58                    | 16.77   | 25.16           |
| 400                        | 60                       | 8  | 0.78            | 1.60                    | 19.16   | 28.74           |
| 450                        | 65                       | 8  | 0.78            | 1.90                    | 21.56   | 32.34           |
| 500                        | 70                       | 8  | 0.78            | 2.00                    | 23.95   | 35.93           |
| 600                        | 75                       | 8 or 6+6                                     | 1.18            | 2.20                    | 28.74   | 43.11           |
| 700                        | 85                       | 8 or 6+6                                     | 1.18            | 4.87                    | 33.53   | 50.30           |
| 800                        | 95                       | 8 or 6+6                                     | 2.66            | 6.87                    | 38.32   | 57.48           |
| 900                        | 100                      | 6+6  | 2.66            | 11.55                   | 43.11   | 64.67           |
| 1000                       | 115                      | 6+6  | 2.66            | 15.70                   | 47.90   | 71.85           |
| 1100                       | 120                      | 6+6  | 2.66            | 19.61                   | 52.69   | 79.00           |
| 1200                       | 125                      | 8+8  | 3.55            | 21.25                   | 57.48   | 86.22           |
| 1400                       | 140                      | 8+8  | 3.55            | 30.00                   | 67.06   | 100.60          |
| 1600                       | 165                      | 8+8  | 3.55            | 50.63                   | 76.64   | 114.96          |
| 1800                       | 180                      | 12+12  | 9.36            | 64.19                   | 86.22   | 129.33          |
| 2000                       | 190                      | 12+12  | 9.36            | 83.12                   | 95.80   | 143.70          |
| 2200                       | 210                      | 12+12  | 9.36            | 105.53                  | 105.40  | 158.07          |
| 2400                       | 225                      | 12+12  | 14.88           | 133.30                  | 115.00  | 172.44          |

NOTE — Concrete for pipes shall have a minimum compressive strength of 35 N/mm<sup>2</sup> at 28 days

**H: Table 6 Design and Strength Test Requirements of Concrete Pipes of Class NP4-Reinforced Concrete, Medium Duty, Non-pressure Pipes**

(Clauses 6.1.1, 6.1.2, 6.1.3, 6.2.2, 7.3.2, 8.1 and Table 20 of IS 458:2003)

| Internal Diameter of Pipes | Barred wall Thickness | Reinforcements                               |                 |                         | Strength Test requirements for Three Edge Bearing Test. |                 |
|----------------------------|-----------------------|--|-----------------|-------------------------|---|-----------------|
|                            |                       | Longitudinal, Mild Steel or Hard Drawn Steel |                 | Spiral Hard Drawn Steel | Load to Produce 0.25 mm Crack                           | Ultimate Load   |
| mm                         | mm                    | Minimum Number                               | kg/linear metre | kg/linear metre         | kN/linear metre   | kN/linear metre |
| (1)                        | (2)                   | (3)  | (4)             | (5)                     | (6)   | (7)             |
| 80                         | 25                    | 6  | 0.59            | 0.24                    | 22.10   | 33.15           |
| 100                        | 25                    | 6  | 0.59            | 0.36                    | 22.10   | 33.15           |
| 150                        | 25                    | 6  | 0.59            | 0.74                    | 22.30   | 34.95           |
| 200                        | 30                    | 6  | 0.59            | 1.30                    | 24.60   | 36.90           |
| 225                        | 30                    | 6  | 0.59            | 1.64                    | 25.20   | 37.80           |
| 250                        | 30                    | 6  | 0.59            | 1.98                    | 25.50   | 38.25           |
| 300                        | 40                    | 8  | 0.78            | 2.71                    | 26.40   | 39.60           |
| 350                        | 75                    | 8  | 0.78            | 3.14                    | 29.80   | 44.70           |
| 400                        | 75                    | 8  | 0.78            | 3.52                    | 33.90   | 50.90           |
| 450                        | 75                    | 8  | 0.78            | 3.88                    | 36.90   | 55.30           |
| 500                        | 75                    | 8  | 0.78            | 5.96                    | 40.00   | 61.20           |
| 600                        | 85                    | 8 or 6+6                                     | 2.34            | 9.63                    | 46.30   | 69.40           |
| 700                        | 85                    | 8 or 6+6                                     | 3.44            | 14.33                   | 52.20   | 78.30           |
| 800                        | 95                    | 8 or 6+6                                     | 3.44            | 21.20                   | 59.30   | 79.10           |
| 900                        | 100                   | 6+6  | 3.34            | 27.13                   | 66.30   | 99.40           |
| 1000                       | 115                   | 8+8  | 6.04            | 35.48                   | 72.60   | 108.90          |
| 1100                       | 115                   | 8+8  | 6.04            | 43.76                   | 80.40   | 120.60          |
| 1200                       | 120                   | 8+8  | 6.04            | 53.07                   | 88.30   | 132.40          |
| 1400                       | 135                   | 8+8  | 9.36            | 77.62                   | 104.20  | 156.40          |
| 1600                       | 140                   | 12+12  | 9.36            | 108.97                  | 119.60  | 179.50          |
| 1800                       | 150                   | 12+12  | 14.88           | 150.22                  | 135.30  | 203.00          |
| 2000                       | 170                   | 12+12  | 14.88           | 151.79                  | 135.30  | 203.00          |
| 2200                       | 185                   | 12+12  | 14.88           | 160.90                  | 142.20  | 213.30          |
| 2400                       | 200                   | 12+12  | 14.88           | 216.96                  | 155.00  | 232.50          |
| 2600                       | 215                   | 12+12  | 14.88           | 258.93                  | 166.70  | 250.00          |

#### NOTES

1. If mild Steel is used for spiral reinforcement, the weight specified under col 5 shall be increased to 140/125.
2. The longitudinal reinforcement given in this table is valid for pipes up to 25m effective length for internal diameter of pipe up to 250 mm and 3 m effective length for higher diameter pipes.
3. The total mass of longitudinal reinforcement shall be calculated by multiplying the values given in col 4 by the length of the pipe and then deducting for the cover length provided at the two ends.
4. Concrete for pipes shall have a minimum compressive strength of 35 N/mm<sup>2</sup> at 28 days.

**I: Table 8 Design and Strength Test Requirements of Concrete Pipes of Class NP4-Reinforced Concrete, Heavy Duty, Non-pressure Pipes made by Vibrated Casting Process**

(Clauses 5.5.1, 6.1.1, 6.1.2.1, 6.1.3, 6.2.2, 7.3.2, 8.1 and Table 20 of IS 458:2003)

| Internal Diameter of Pipes | Barred wall Thickness | Reinforcements                               |                 |                         | Strength Test requirements for Three Edge Bearing Test. |                 |
|----------------------------|-----------------------|--|-----------------|-------------------------|---|-----------------|
|                            |                       | Longitudinal, Mild Steel or Hard Drawn Steel |                 | Spiral Hard Drawn Steel | Load to Produce 0.25 mm Crack                           | Ultimate Load   |
| mm                         | mm                    | Minimum Number                               | Kg/linear metre | kg/linear metre         | kN/linear metre   | kN/linear metre |
| (1)                        | (2)                   | (3)  | (4)             | (5)                     | (6)   | (7)             |
| 300                        | 50                    | 8  | 0.78            | 1.53                    | 26.40   | 38.60           |
| 350                        | 55                    | 8  | 0.78            | 1.61                    | 29.80   | 44.70           |
| 400                        | 60                    | 8  | 0.78            | 1.97                    | 33.90   | 50.90           |
| 450                        | 65                    | 8  | 0.78            | 3.36                    | 36.90   | 55.30           |
| 500                        | 70                    | 8  | 0.78            | 5.56                    | 40.00   | 61.20           |
| 600                        | 75                    | 8 or 6+6                                     | 2.34            | 8.50                    | 46.30   | 69.40           |
| 700                        | 85                    | 8 or 6+6                                     | 3.44            | 12.78                   | 52.20   | 78.30           |
| 800                        | 95                    | 8 or 6+6                                     | 3.44            | 16.72                   | 59.30   | 89.10           |
| 900                        | 100                   | 6+6  | 3.44            | 20.92                   | 66.30   | 99.40           |
| 1000                       | 115                   | 8+8  | 6.04            | 26.70                   | 72.60   | 108.90          |
| 1100                       | 120                   | 8+8  | 6.04            | 35.60                   | 80.40   | 120.60          |
| 1200                       | 125                   | 8+8  | 6.04            | 42.42                   | 88.30   | 132.40          |
| 1400                       | 140                   | 8+8  | 9.36            | 53.39                   | 104.20  | 156.40          |
| 1600                       | 165                   | 12+12  | 9.36            | 79.92                   | 119.60  | 179.50          |
| 1800                       | 180                   | 12+12  | 14.88           | 85.75                   | 135.30  | 203.00          |
| 2000                       | 190                   | 12+12  | 14.88           | 108.00                  | 135.30  | 203.00          |

NOTES: - Concrete for pipe shall have a minimum compressive strength of 35 N/mm<sup>2</sup> at 28 days

**Marking**

The following information shall be clearly marked on each pipe/collar:

- Indication of the source of manufacture.
- Class and Size of pipe/collar.
- The words 'SPUN PIPE' or 'VIBRATED CAST PIPE (UNREINFORCED)' or 'VIBRATED CAST PIPE (REINFORCED)' as may be applicable, for pipes; and
- Date of manufacture

The above information shall be clearly marked on outside only for pipes up to and including 350 mm internal diameter, and both outside and inside for pipes above 350 mm internal diameter. The information shall be clearly marked only on the outside for collars.

'Each pipe/collar may also be marked with the Standard Mark'

The Number of tests and criteria for conformity shall be as given in table 22 of IS 458:2003  
**Table 22 Scale of Sampling and Permissible number of Defectives.**

(Clauses 11.1.3, 11.2.1.1 and 11.2.2 of IS 458:2003)

| No. of Pipes in the Lot | For Requirement Under Clauses 8 and 9 of IS 458:2003 |                                  | Sample Size for Test Under clause 10.2 of IS 458:2003 (Excluding Ultimate Load Test) |
|-------------------------|--|----------------------------------|--|
|                         | Sample Size  | Permissible Number or Defectives |  |
| (1)                     | (2)  | (3)                              | (4)  |
| Up to 50                | 8  | 0                                | 2  |
| 51 to 100               | 13   | 1                                | 3  |
| 101 to 300              | 20   | 2                                | 5  |
| 301 to 500              | 32   | 3                                | 7  |
| 501 and above           | 50   | 5                                | 10   |

The Lot shall be declared as conforming to these requirements if the number of defectives found in the sample does not exceed the number of defectives given in col. 3 of Table 22.

**Tolerances: (As per IS 458:2003 Para 8.2)**

The following tolerances shall be permitted:

| Sl. No. | Dimensions                                     | Tolerances                     |
|---------|--|--------------------------------|
| (i)     | Overall length                                 | ± 1 percent of standard length |
| (ii)    | Internal diameter of pipes:                    |                                |
|         | (a) Up to and including 300                    | ± 3 mm                         |
|         | (b) Over 300 mm and up to and including 600 mm | ± 5 mm                         |
|         | (c) Over 600 mm                                | ± 10 mm                        |
| (iii)   | Barrel wall thickness:                         |                                |
|         | (a) Up to and including 30 mm                  | +2 mm<br>-1 mm                 |
|         | (b) Over 30 mm up to and including 50 mm       | +3 mm<br>-1.5 mm               |
|         | (c) Over 50 mm up to and including 65 mm       | +4 mm<br>-2 mm                 |
|         | (d) Over 65 mm up to and including 80 mm       | +5 mm<br>-2.5 mm               |
|         | (e) Over 80 mm up to and including 95 mm       | +6 mm<br>-3 mm                 |
|         | (f) Over 95 mm                                 | +7 mm<br>-3.5 mm               |

**Note-** In case of pipes with flexible rubber ring joints, the tolerance on thickness near the ends will have to be reduced. Near the rubber ring joints, the tolerance on thickness shall be as given in tables 13 to 19 of IS 458:2003 in case of pipes manufactured by spinning process and as given in table 15 and table 16 of IS 458:2003 in case of pipes manufactured by vibrated casting process.

**RECOMMENDED SIZES OF SEPTIC TANKS***(Clause 19.9)***RECOMMENDED SIZES OF SEPTIC TANKS FOR 5-20 USERS**

| No of users | Length<br>(m) | Breath<br>(m) | Liquid depth (cleaning interval of) |               |
|-------------|---------------|---------------|-------------------------------------|---------------|
|             |               |               | 1 year<br>(m)                       | 2 year<br>(m) |
| 05          | 1.5           | 0.75          | 1.0                                 | 1.05          |
| 10          | 2.0           | 0.90          | 1.0                                 | 1.40          |
| 15          | 2.0           | 0.90          | 1.3                                 | 2.00          |
| 20          | 2.3           | 1.10          | 1.3                                 | 1.80          |

**Notes :**

1. The capacities are recommended on the assumption that discharges from only WC will be treated in the septic tank.
2. A provision of 300 mm should be made for free board.
3. The sizes of septic tanks are based on certain assumptions, while choosing the size of septic tank exact calculation shall be made.

**RECOMMENDED SIZES OF SEPTIC TANKS FOR RESIDENTIAL COLONIES**

| No of users | Length<br>(m) | Breath<br>(m) | Liquid depth (cleaning interval of) |               |
|-------------|---------------|---------------|-------------------------------------|---------------|
|             |               |               | 1 year<br>(m)                       | 2 year<br>(m) |
| 050         | 5.0           | 2.0           | 1.0                                 | 1.24          |
| 100         | 7.5           | 2.65          | 1.0                                 | 1.24          |
| 150         | 10.0          | 3.0           | 1.0                                 | 1.24          |
| 200         | 12.0          | 3.3           | 1.0                                 | 1.24          |
| 300         | 15.0          | 4.0           | 1.0                                 | 1.24          |

**Notes :**

1. A provision of 300 mm should be made for free board.
2. The sizes of the septic tank are based on certain assumptions while choosing the size of septic tank, exact calculation shall be made.
3. For population over 100, the tank may be divided into independent parallel chambers for ease of maintenance and cleaning.

**RECOMMENDED SIZES OF SEPTIC TANKS FOR HOSTEL AND BOARDING SCHOOLS**

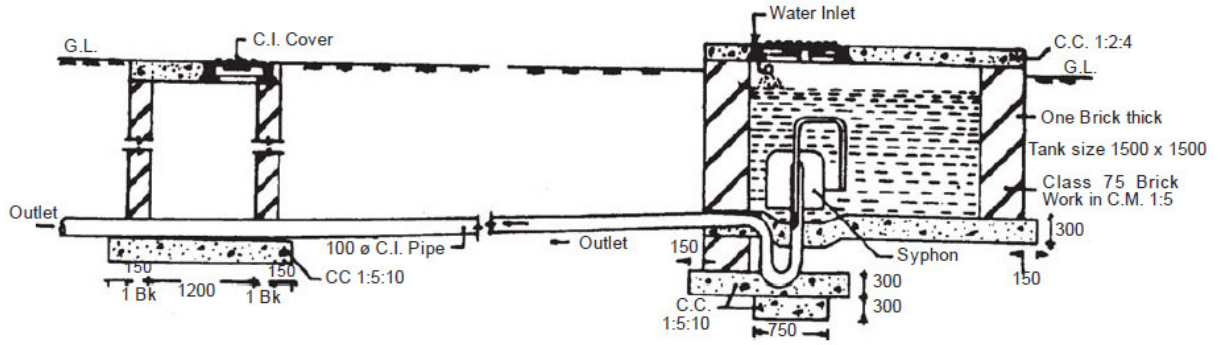
| No of users | Length<br>(m) | Breath<br>(m) | Liquid depth (D) for stated intervals of sludge withdrawal |                       |
|-------------|---------------|---------------|--|-----------------------|
|             |               |               | Once in a year<br>(m)                                      | Once in 2 year<br>(m) |
| 50          | 5.0           | 1.6           | 1.3  | 1.4                   |
| 100         | 5.7           | 2.1           | 1.4  | 1.7                   |
| 150         | 7.7           | 2.4           | 1.4  | 1.7                   |
| 200         | 8.9           | 2.7           | 1.4  | 1.7                   |
| 300         | 10.7          | 3.3           | 1.4  | 1.7                   |

**Notes :**

1. A provision of 300 mm should be made for free board.
2. The sizes of the septic tank are based on certain assumptions while choosing the size of septic tank exact calculation shall be made.
3. For population over 100, the tank may be divided into independent parallel chambers for ease of maintenance and cleaning.

# FLUSHING TANK

Sub Head : Drainage  
Clause : 19.0

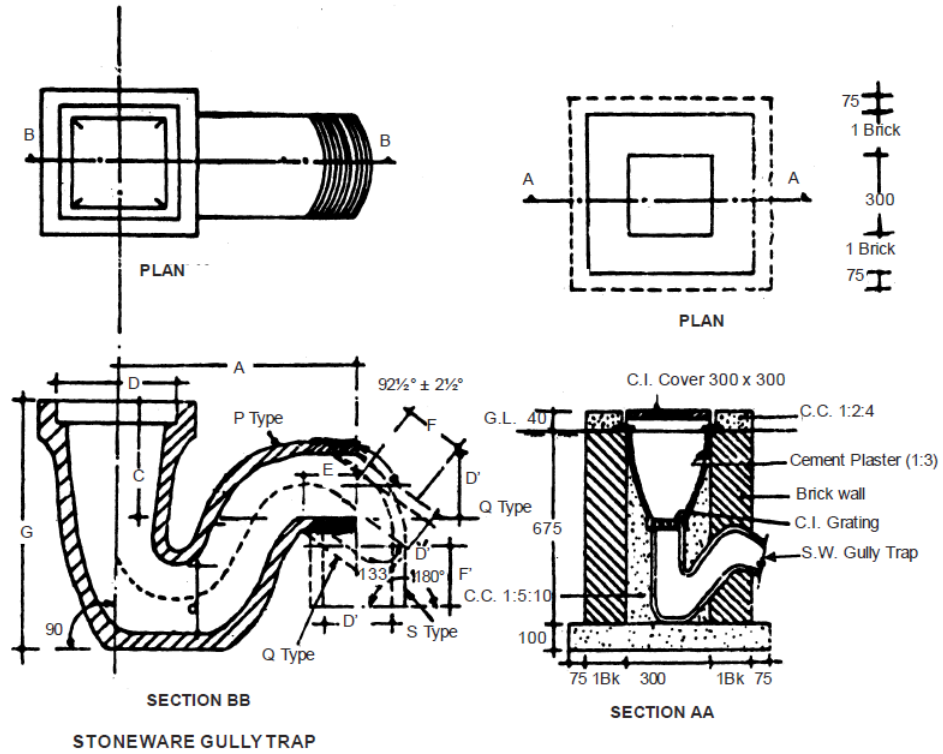


Drawing Not to Scale  
All Dimensions are in mm

Fig. 19.1 : Flushing Tank

# GULLY TRAP

Sub Head : Drainage  
Clause : 19.8



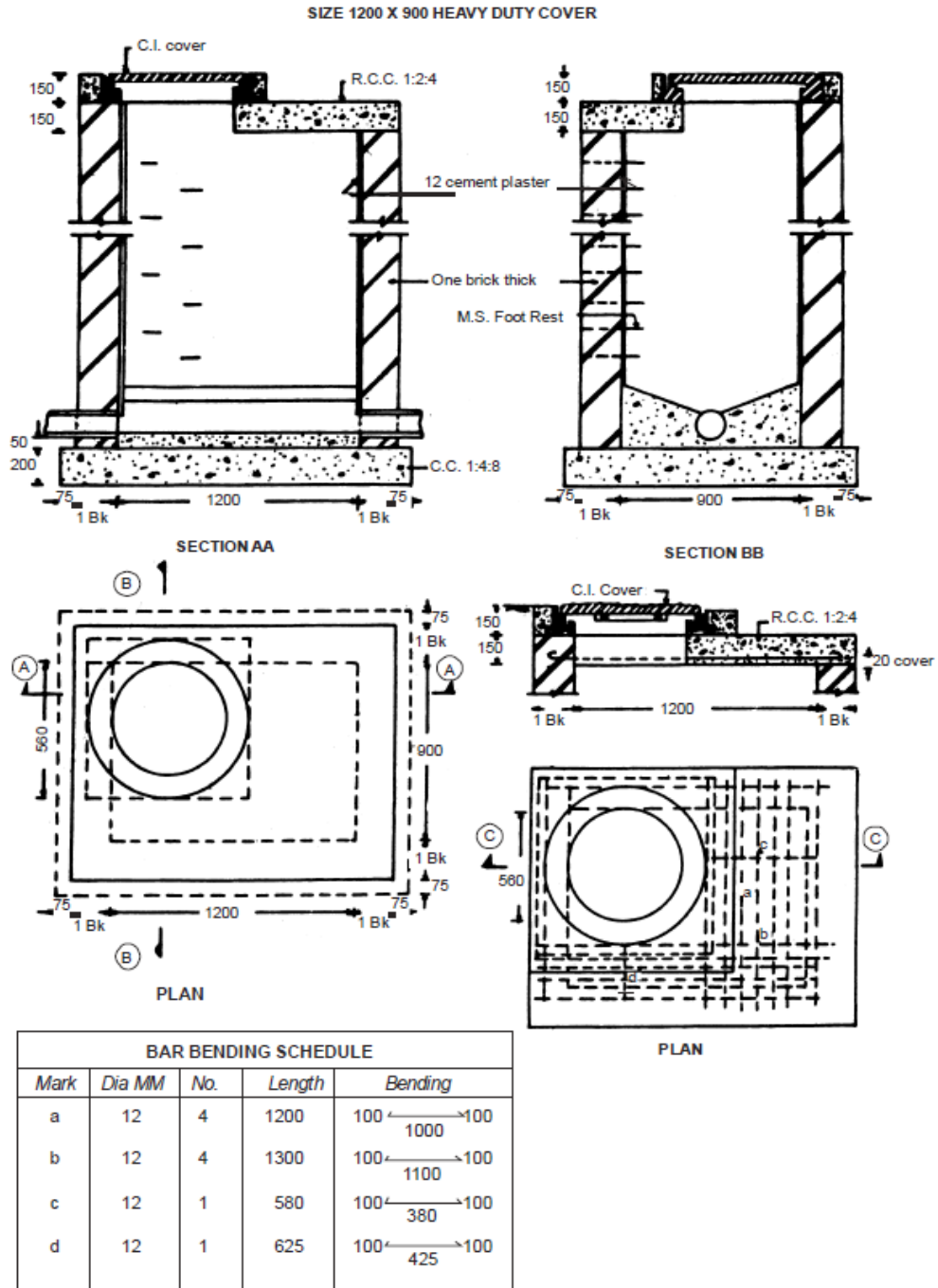
| Type | Size    | A   | C   | d   | D   | D'  | E  | F  | F'  | G   |
|------|---------|-----|-----|-----|-----|-----|----|----|-----|-----|
| P    | 100x100 | 305 | 175 | 100 | 100 | 100 | 65 | -  | -   | 330 |
|      | 125x100 | 265 | 165 | 100 | 125 | 100 | 60 | -  | -   | 345 |
|      | 150x100 | 330 | 165 | 100 | 150 | 100 | 75 | -  | -   | 346 |
|      | 180x100 | 320 | 200 | 100 | 180 | 100 | 65 | -  | -   | 380 |
| Q    | 180x150 | 405 | 270 | 150 | 180 | 150 | 75 | -  | -   | 520 |
|      | 125x100 | 330 | 165 | 100 | 125 | 100 | -  | 80 | -   | 345 |
| S    | 125x100 | 290 | 165 | 100 | 125 | 100 | -  | -  | 100 | 345 |
|      | 150x100 | 330 | 165 | 100 | 150 | 100 | -  | -  | 115 | 346 |
|      | 180x150 | 445 | 275 | 150 | 180 | 150 | -  | -  | 125 | 520 |

Drawing Not to Scale  
All Dimensions are in mm

Fig. 19.2 : Gully Trap

# MANHOLE

Sub Head : Drainage  
Clause : 19.4



Drawing Not to Scale  
All Dimensions are in mm

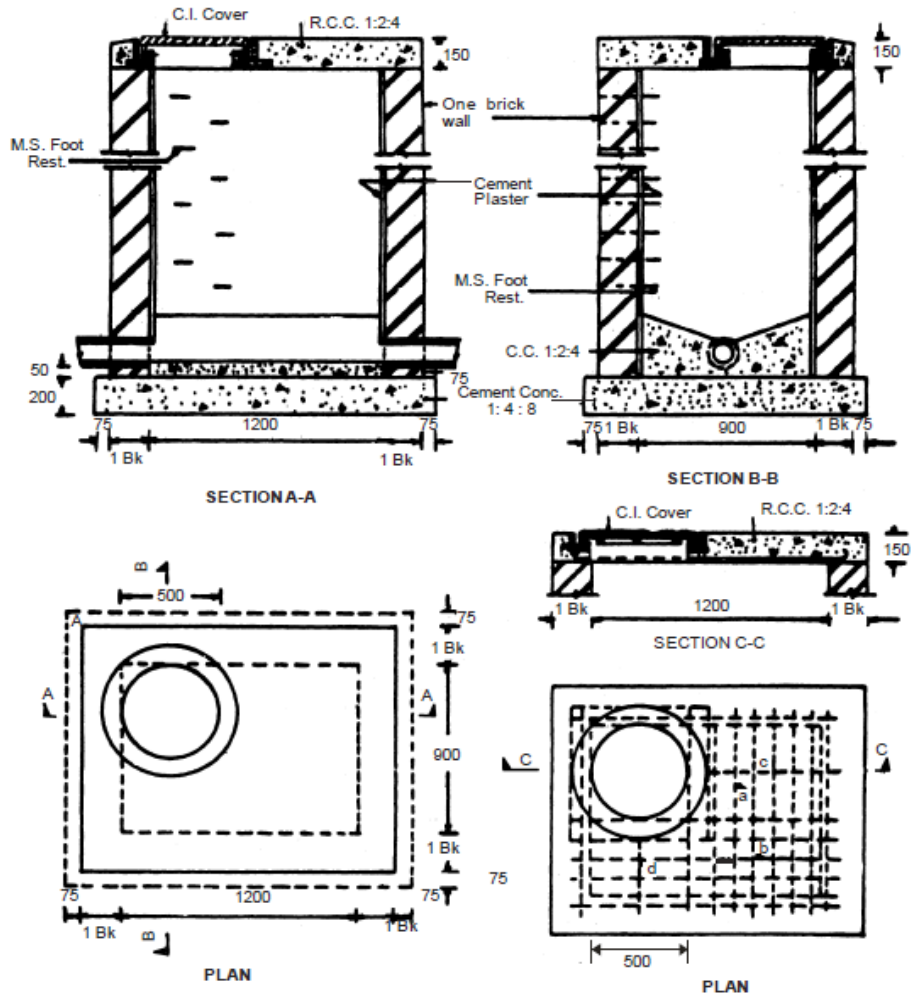
Fig. 19.3 : Manhole



# MANHOLE (Contd.)

Sub Head : Drainage  
Clause : 19.4

SIZE 1200 X 900 WITH MEDIUM DUTY COVER



| BAR BENDING SCHEDULE |        |     |        |   |
|----------------------|--------|-----|--------|---|
| Mark                 | Dia MM | No. | Length | Bending                                 |
| a                    | 12     | 6   | 1300   | 100 $\leftarrow$ 1100 $\rightarrow$ 100 |
| b                    | 12     | 6   | 1800   | 100 $\leftarrow$ 1400 $\rightarrow$ 100 |
| c                    | 12     | 1   | 980    | 100 $\leftarrow$ 780 $\rightarrow$ 100  |
| d                    | 12     | 1   | 680    | 100 $\leftarrow$ 480 $\rightarrow$ 100  |

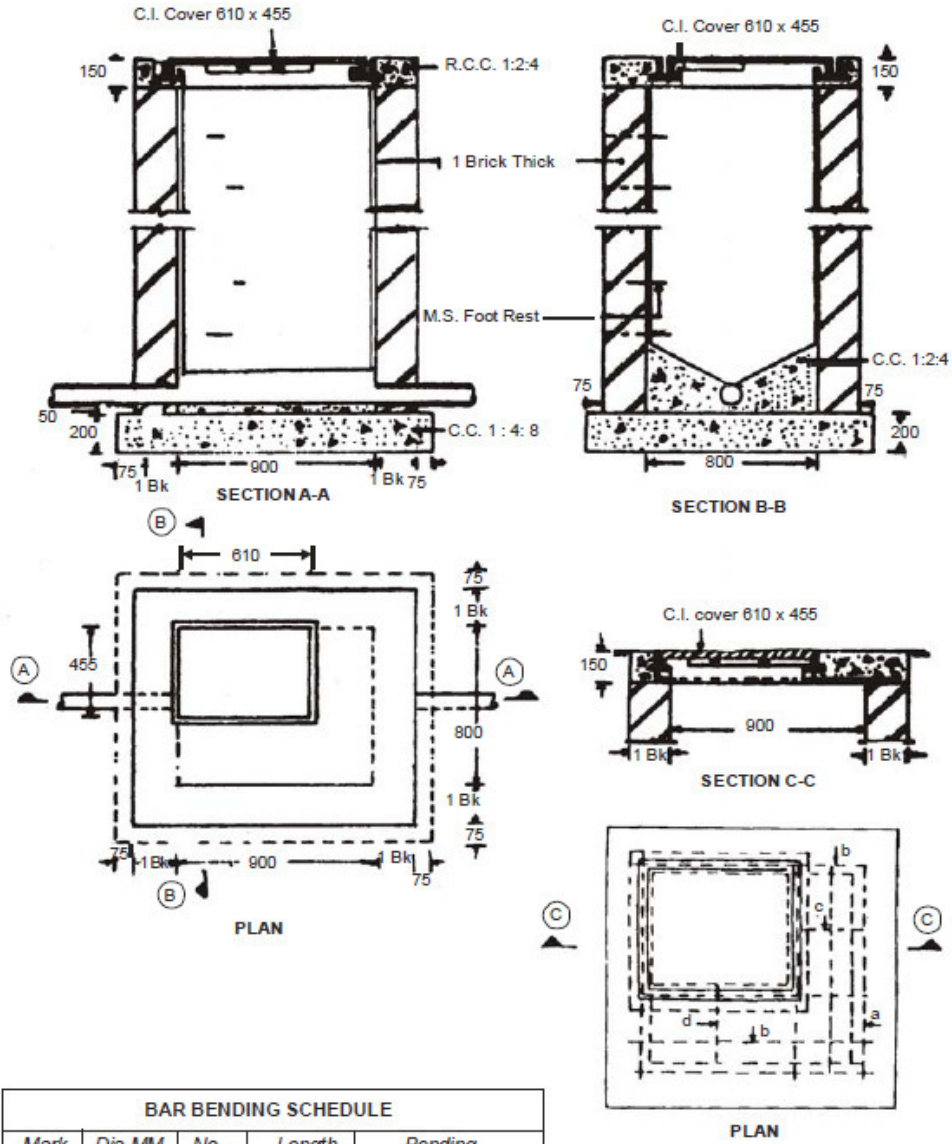
Drawing Not to Scale  
All Dimensions are in mm

Fig. 19.4 : Manhole (Contd.)

# MANHOLE (Contd.)

Sub Head : Drainage  
 Clause : 19.4

SIZE 900 X 800 WITH LIGHT DUTY COVER



| BAR BENDING SCHEDULE |        |     |        |                  |
|----------------------|--------|-----|--------|------------------|
| Mark                 | Dia MM | No. | Length | Bending          |
| a                    | 12     | 4   | 1200   | 100 ↔ 1000 ↔ 100 |
| b                    | 12     | 4   | 1300   | 100 ↔ 1100 ↔ 100 |
| c                    | 12     | 4   | 580    | 100 ↔ 380 ↔ 100  |
| d                    | 12     | 4   | 625    | 100 ↔ 425 ↔ 100  |

Drawing Not to Scale  
 All Dimensions are in mm

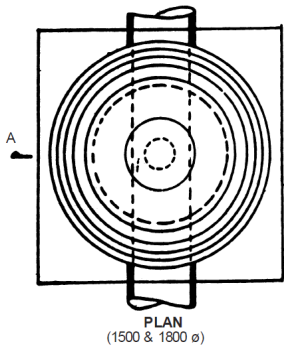
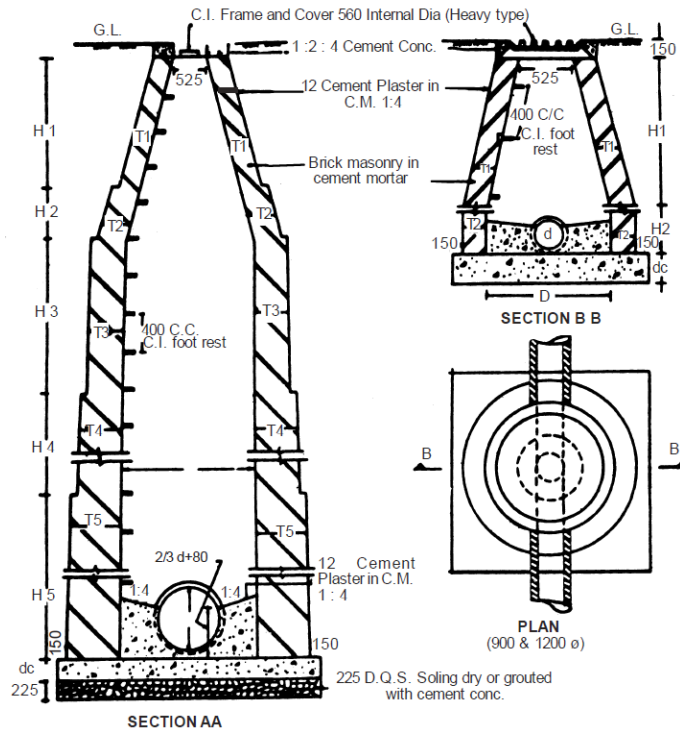
Fig. 19.5 : Manhole (Contd.)



# MANHOLE (Contd.)

Sub Head : Drainage  
Clause : 19.4

MUNICIPAL CORPORATION DELHI DESIGN



H- Height of wall  
T - Thickness of wall  
D - Dia of manhole  
d - Dia of pile  
dc - Depth of bed Conc.

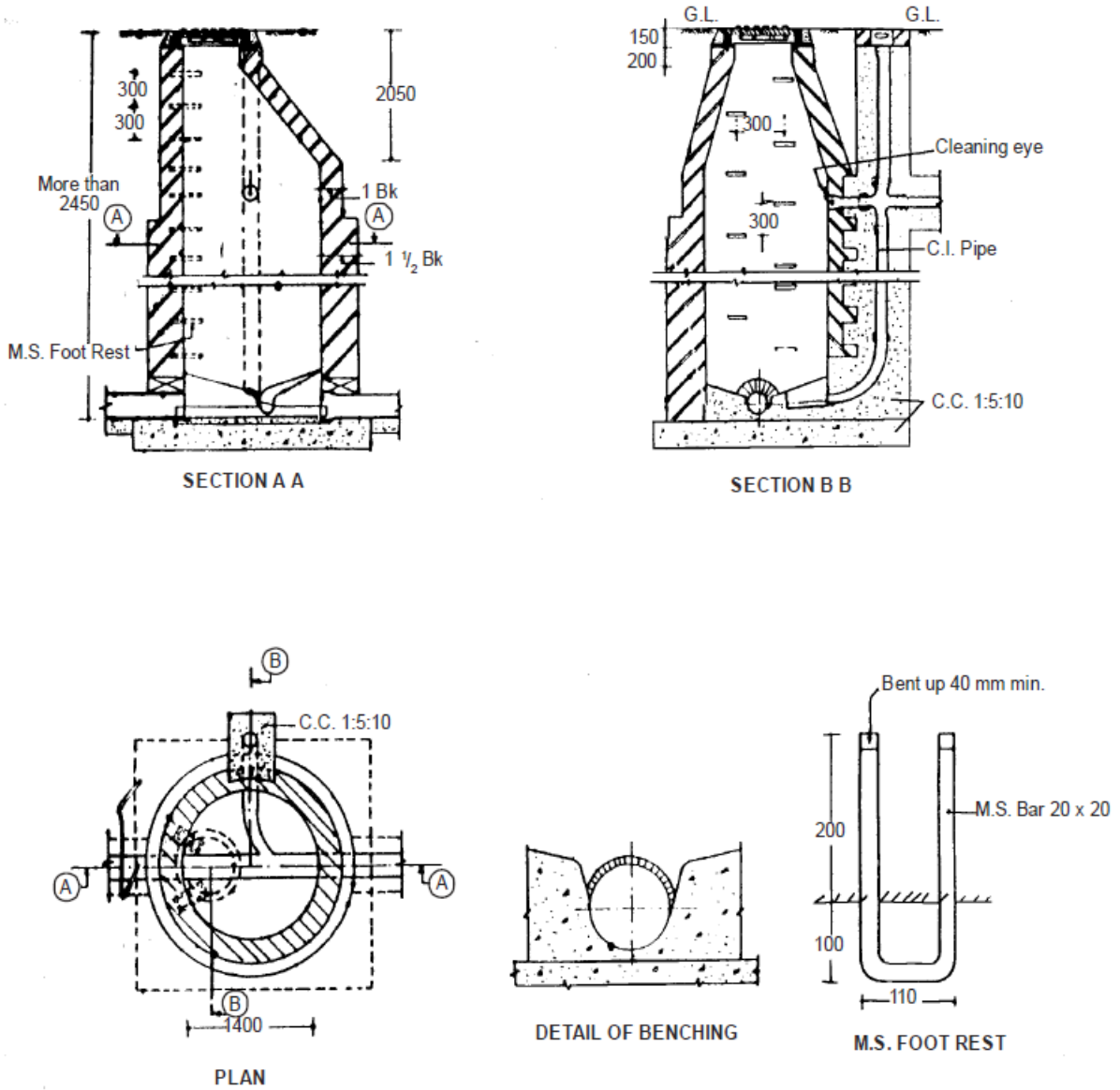
| Dia of manhole | H1   | H2<br>Depth<br>Variable<br>up to 750 | H3   | H4   | H5<br>Depth<br>variable<br>up to<br>4000 | T1   | T2   | T3   | T4   | T5  | Bed<br>Conc<br>dc | Remarks  |
|----------------|------|--------------------------------------|------|------|--|------|------|------|------|-----|-------------------|--|
| 900            | 750  | -                                    | -    | -    | -  | 1 BK | 1 BK | -    | -    | -   | 226               | The soling will be provided where the site Engineer will feel necessary. |
| 1200           | 1350 | -do-                                 | -    | -    | -  | 1 BK | 1 BK | -    | -    | -   | 300               |  |
| 1500           | 1950 | 750                                  | 2100 | 4050 | -do-                                     | 1 BK | 1½Bk | -    | -    | -   | 300               |  |
| 1800           | 1950 | 750                                  | 2250 | 4050 | -do-                                     | 1Bk  | 1½Bk | 2 Bk | 2½Bk | 3Bk | 300               |  |

Drawing Not to Scale  
All Dimensions are in mm

Fig. 19.7 : Manhole (Contd.)

# MANHOLE (With Drop Connections)

**Sub Head : Drainage**  
**Clause : 19.4 & 19.5**

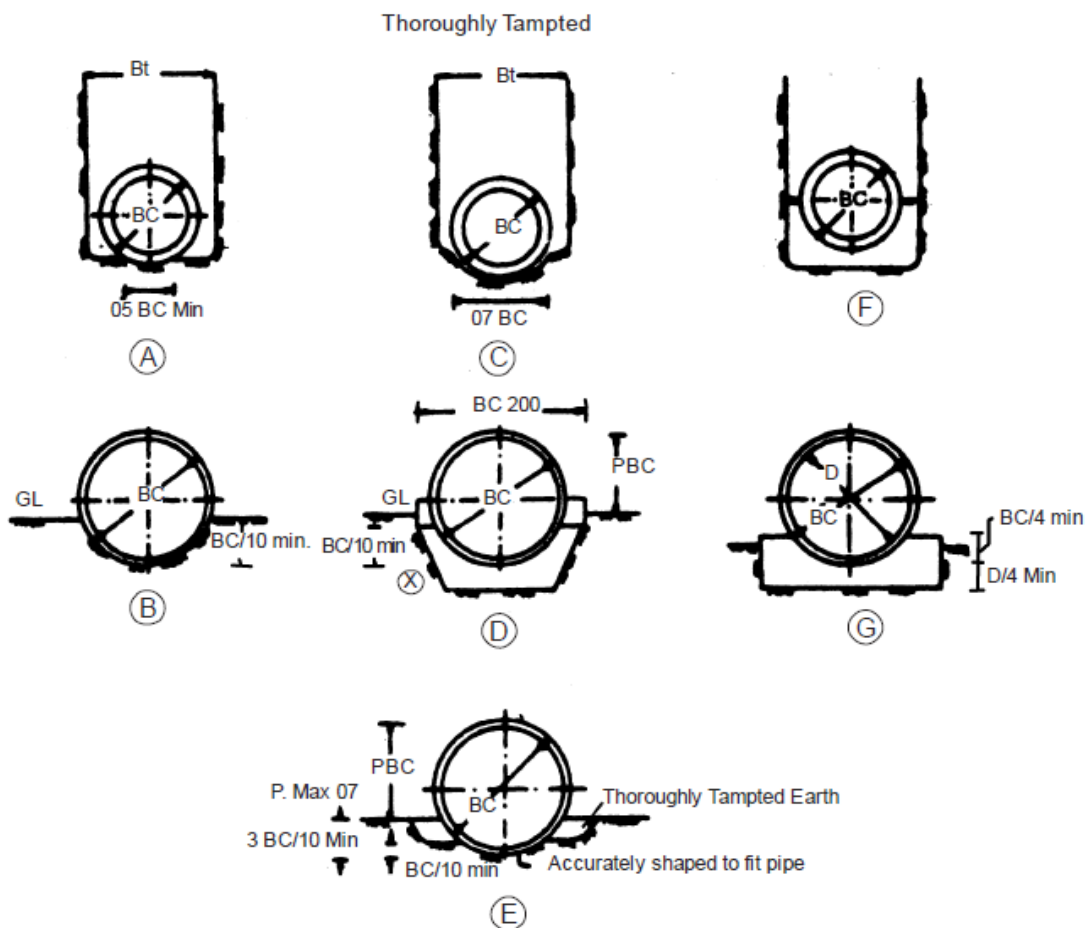


Drawing Not to Scale  
All Dimensions are in mm

**Fig. 19.8 : Manhole (With Drop Connections)**

## BEDDING OF PIPES

Sub Head : Drainage  
Clause : 19.2.2.1



- D = Internal Diameter
- BC = Horizontal Breadth Outside of the Pipes in metres (i.e., external diameter in case of a circular pipe)
- Bt = Horizontal Width of Trench immediately below the top of the pipe in metres
- H = Height of fill above top of pipe in metres
- (X) = Min 200 for 'H' < 5000 when 'H' > 5000, 10 for every 250 of 'H'.

| Fig. | Bedding         | Load Factor |
|------|-----------------|-------------|
| (A)  | Ordinary        | 1.5         |
| (B)  | -do-            | -           |
| (C)  | First Class     | 1.9         |
| (D)  | -do-            | -           |
| (E)  | -do-            | -           |
| (F)  | Concrete Cradle | 2.25 to 3.4 |
| (G)  | -do-            | -           |

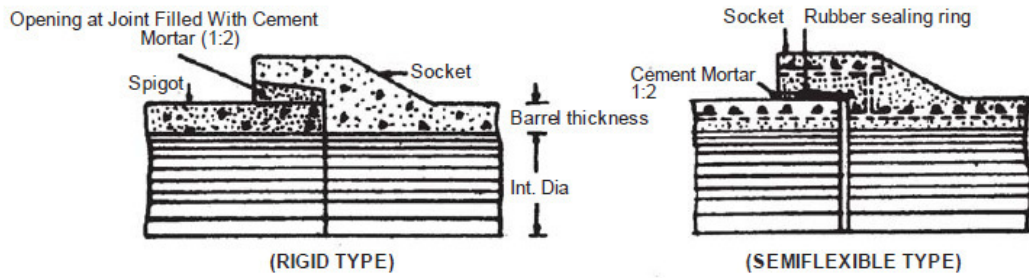
Drawing Not to Scale  
All Dimensions are in mm

**Fig. 19.9 : Bedding of Pipes**

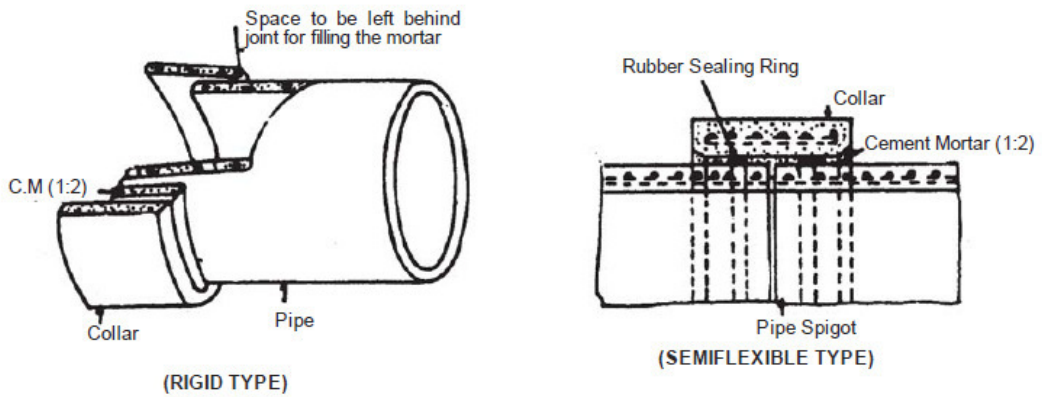


# JOINTS OF CONCRETE PIPES

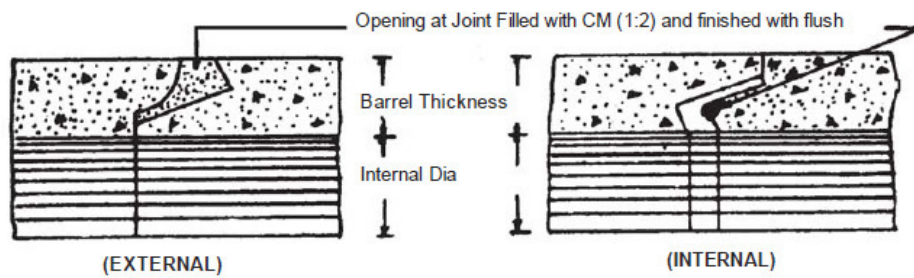
Sub Head : Drainage  
 Clause : 19.2.2.1



## SPIGOT & SOCKET JOINTS



## COLLAR JOINTS



## FLUSH JOINTS

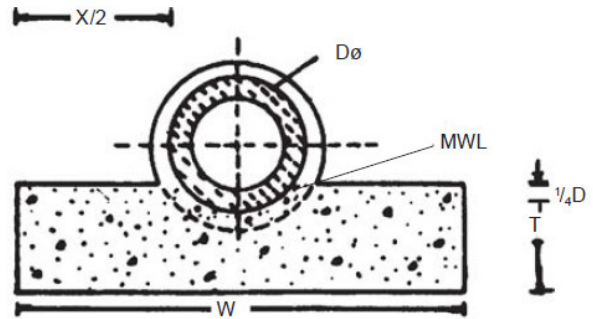
Drawing Not to Scale

Fig. 19.10 : Joints of Concrete Pipes

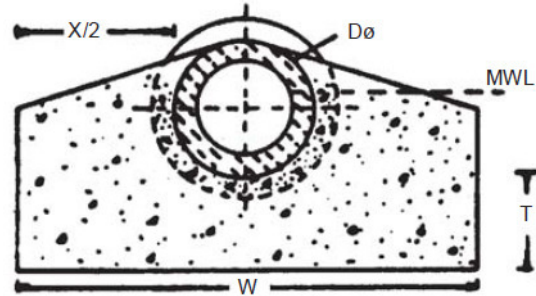
## BEDDING/ENCASING STONEWARE PIPES

Sub Head : Drainage  
Clause : 19.2.1

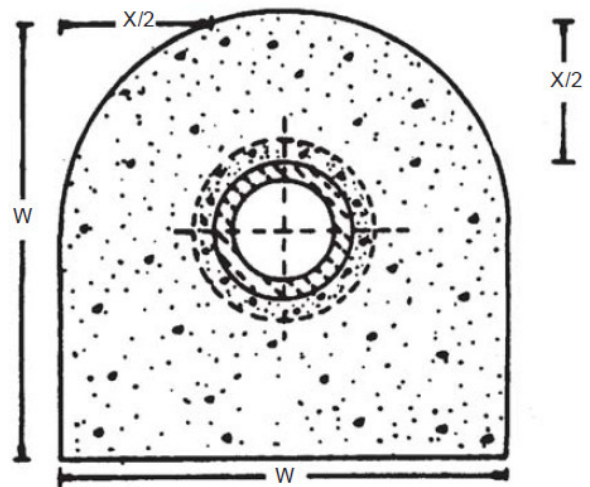
(i) CONCRETE BEDDING



(ii) CONCRETE UPTO HAUNCHES



(iii) CONCRETE ALLROUND



- W =  $D+X$ , Where D is the External Diametre of the pipe  
 X = 300 up to Trench Depth of 1200  
     = 400 Trench Depth more than 1200  
 T = 100 for pipes under 150,  $1/4^{th}$  Internal dia subjected to a min. of 150mm and max. 300 mm for pipes more than 150 Dia  
 MWL = Maximum water level

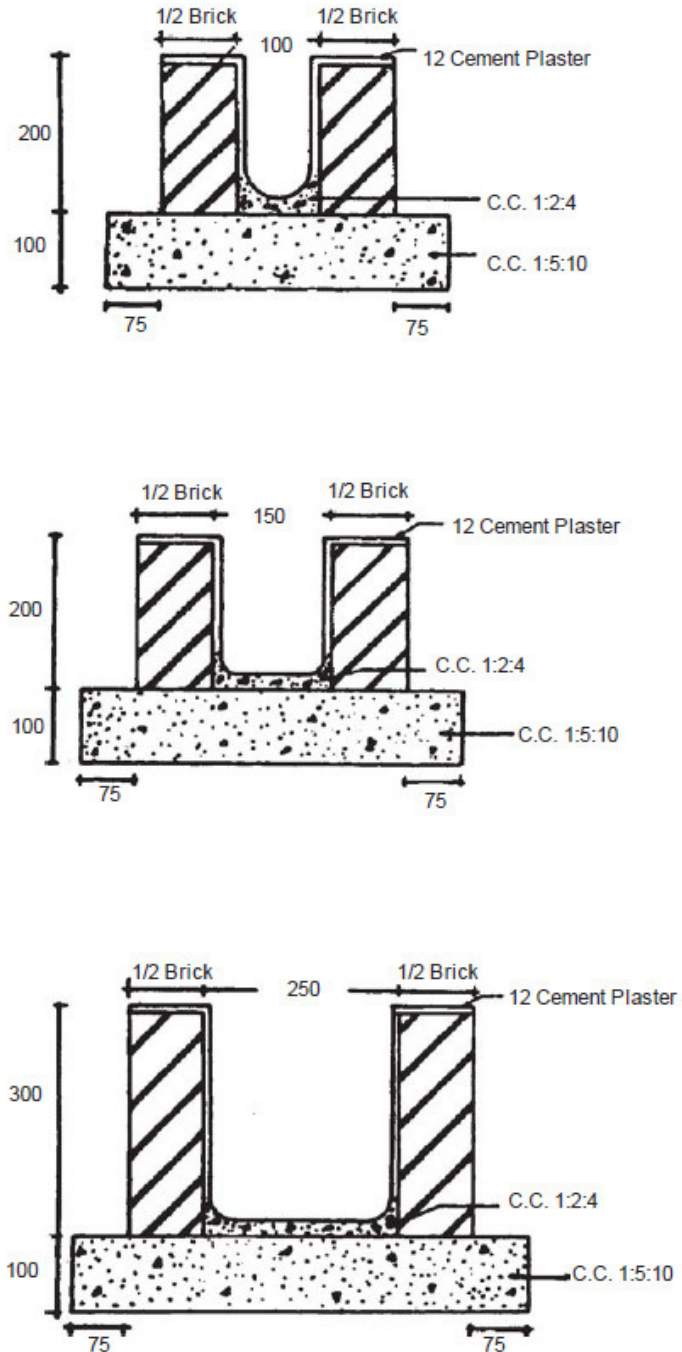
Drawing Not to Scale  
All Dimensions are in mm

**Fig. 19.11: Bedding/Encasing Stoneware Pipes**



# BRICK MASONRY OPEN SURFACE DRAINS

Sub Head : Drainage  
Clause : 19.6

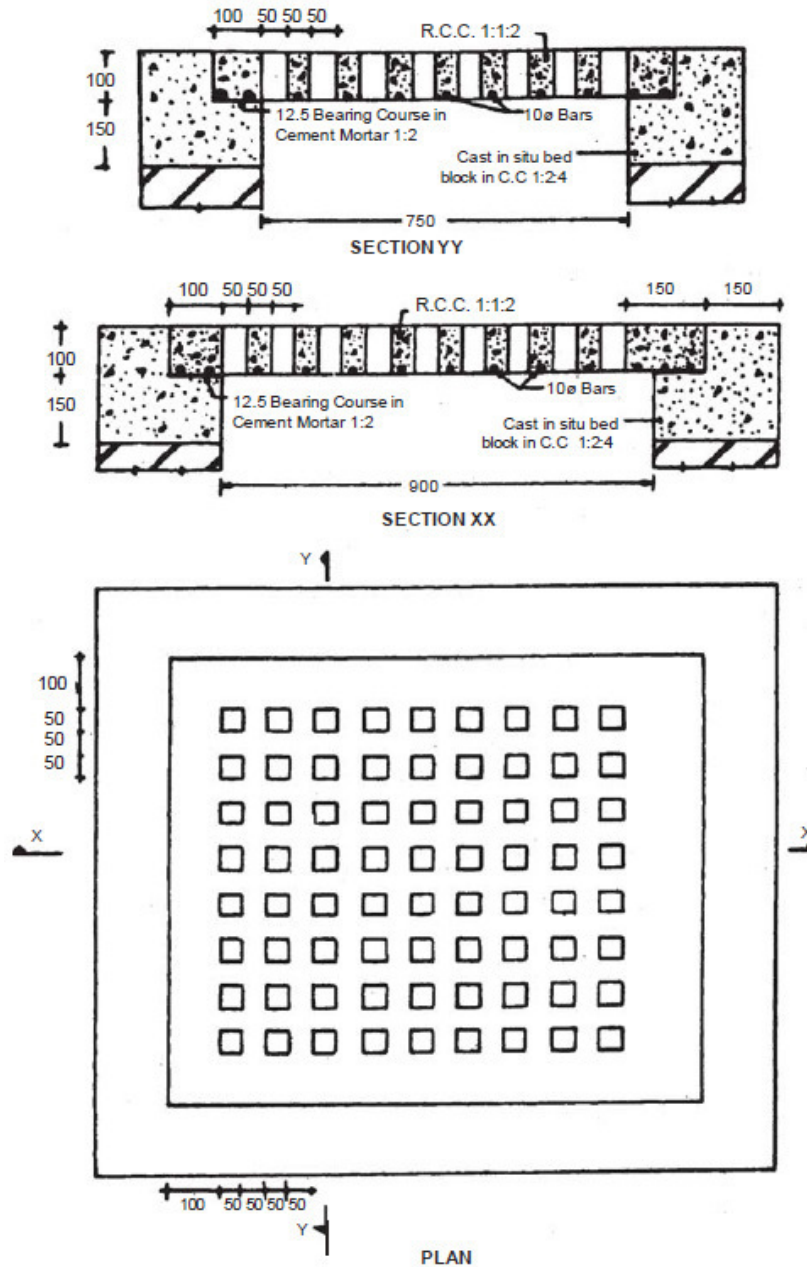


Drawing Not to Scale  
All Dimensions are in mm

Fig. 19.12 : Brick Masonry Open Surface Drains

## R.C.C ROAD GULLY GRATING

Sub Head : Drainage  
Clause : 19.2.4 & 19.7.1

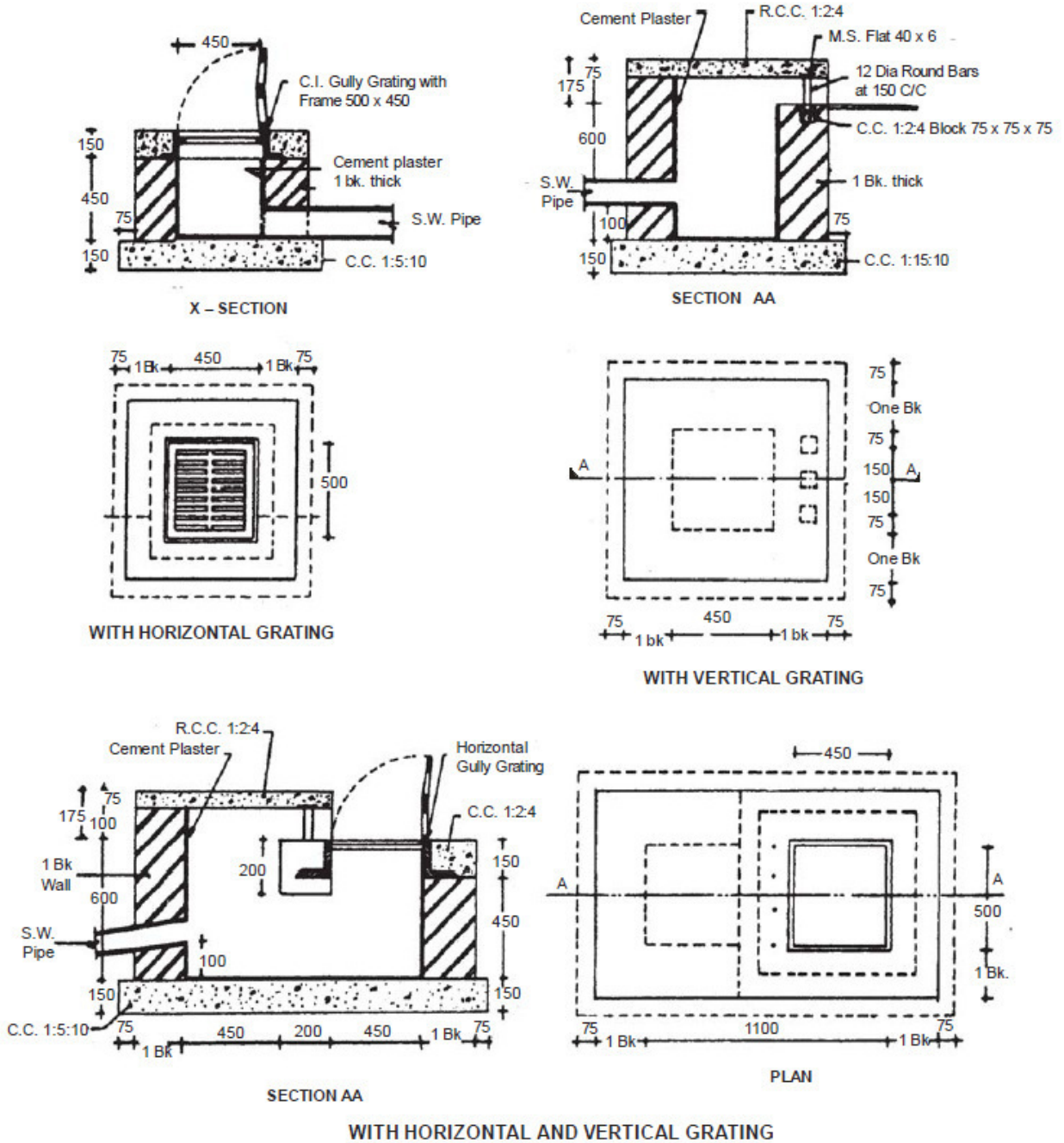


1. Drg. Not to Scale
2. All Dimensions are in mm
3. Clear Cover over Reinforcement shall be 20 mm
4. The Slab Covers shall Cast in R.C.C. 1:1:2
5. The R.C.C.. Cover shall be Properly Cured

Fig. 19.13: R.C.C. Road Gully Grating

# R.C.C. ROAD GULLY CHAMBER

Sub Head : Drainage  
Clause : 19.7

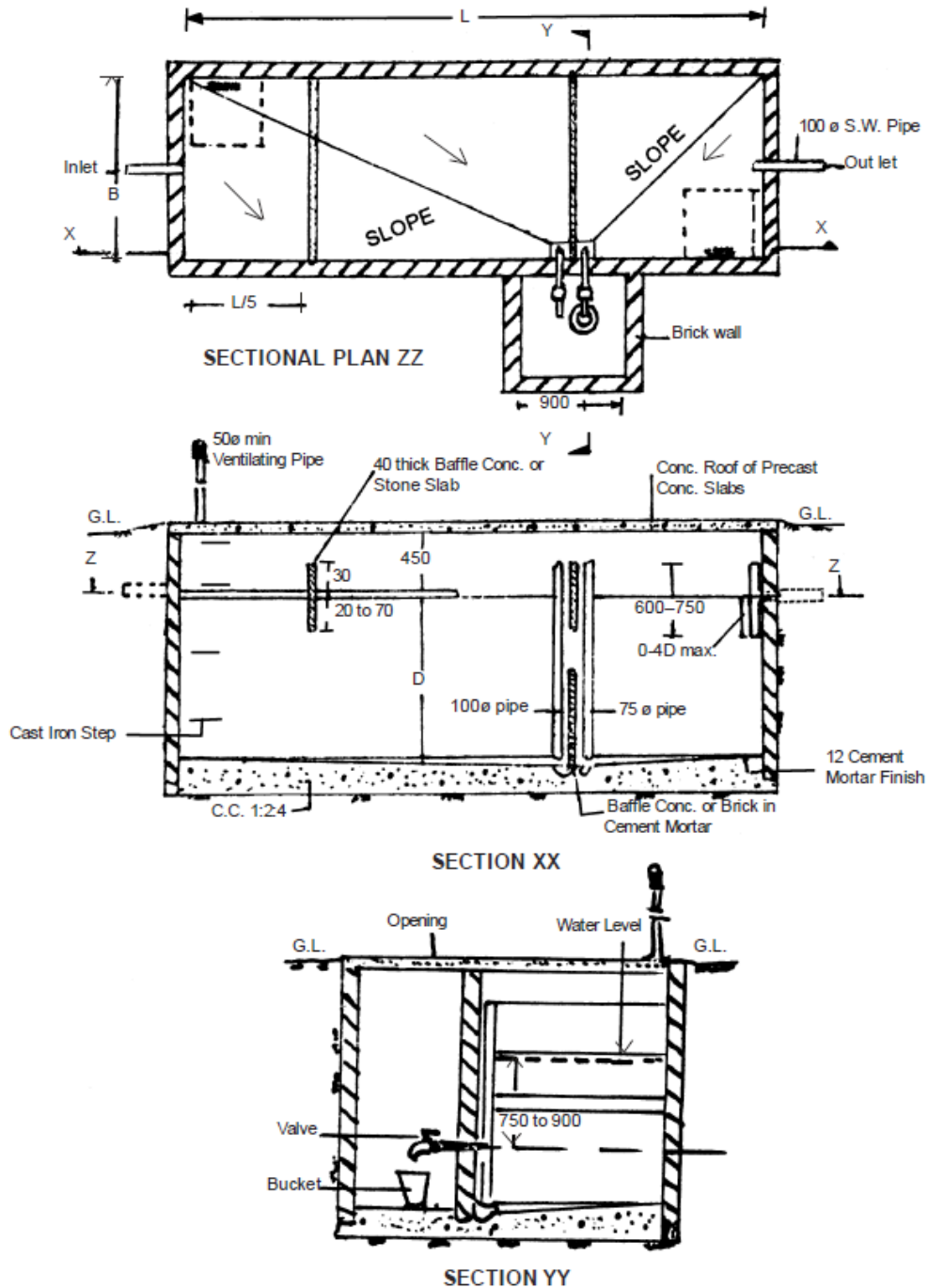


Drawing Not to Scale  
All Dimensions are in mm

Fig. 19.14 : Road Gully Chamber

# SEPTIC TANK

Sub Head : Drainage  
Clause : 19.9

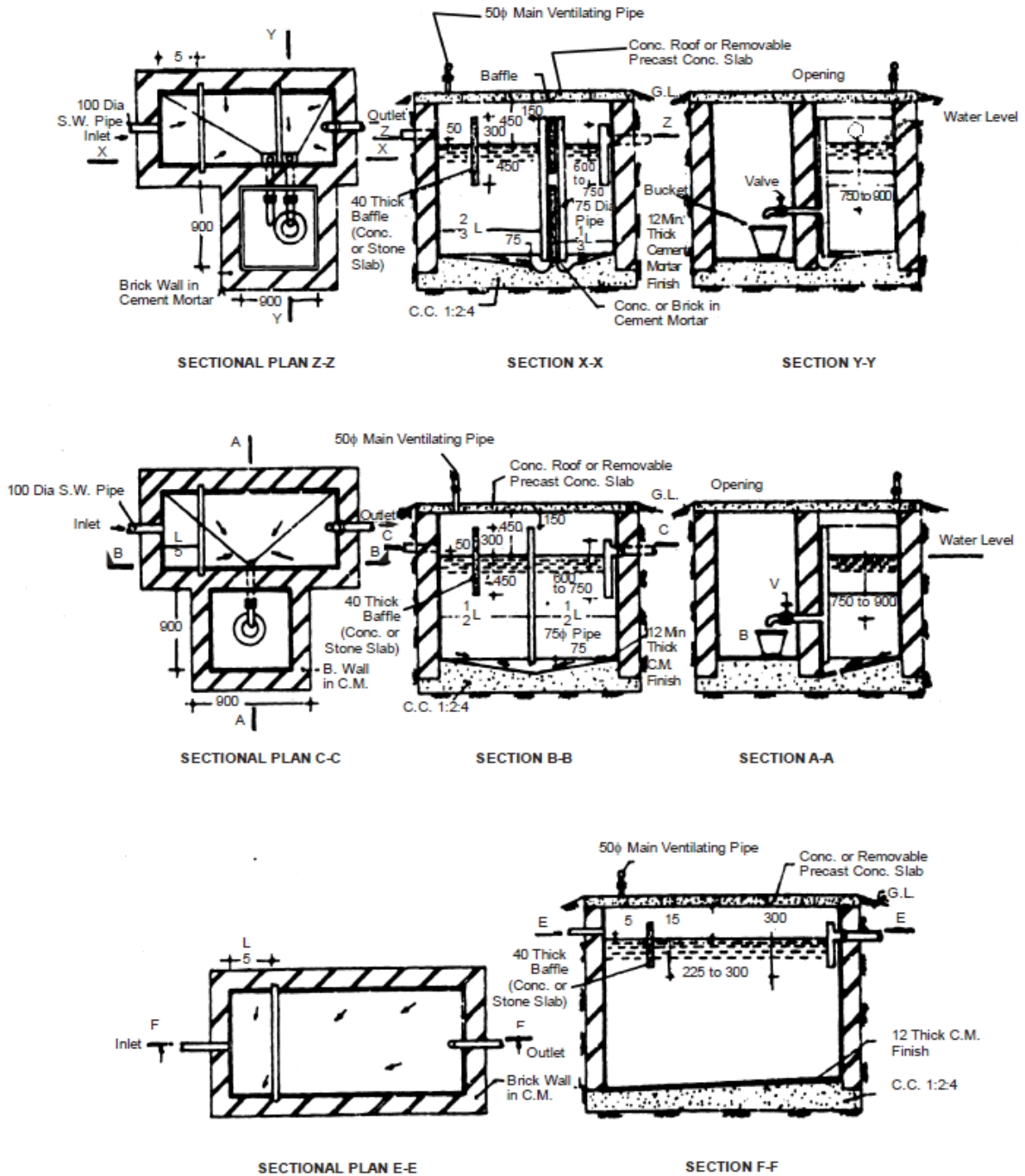


Drawing Not to Scale  
All Dimensions are in mm

Fig. 19.15 : Septic Tank

# SEPTIC TANK (Contd.)

Sub Head : Drainage  
Clause : 19.9



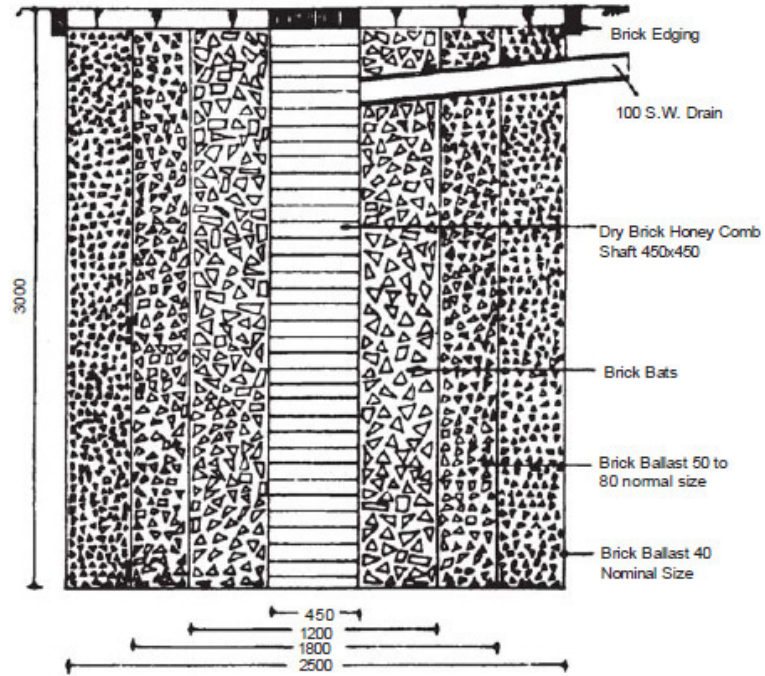
Drawing Not to Scale  
All Dimensions are in mm

Fig. 19.16 : Septic Tank (Contd.)

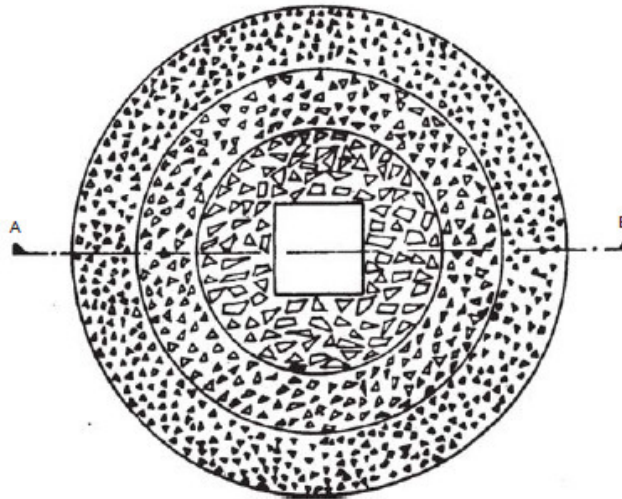


# SOAK PIT

Sub Head : Drainage  
Clause : 19.10



SECTION AB



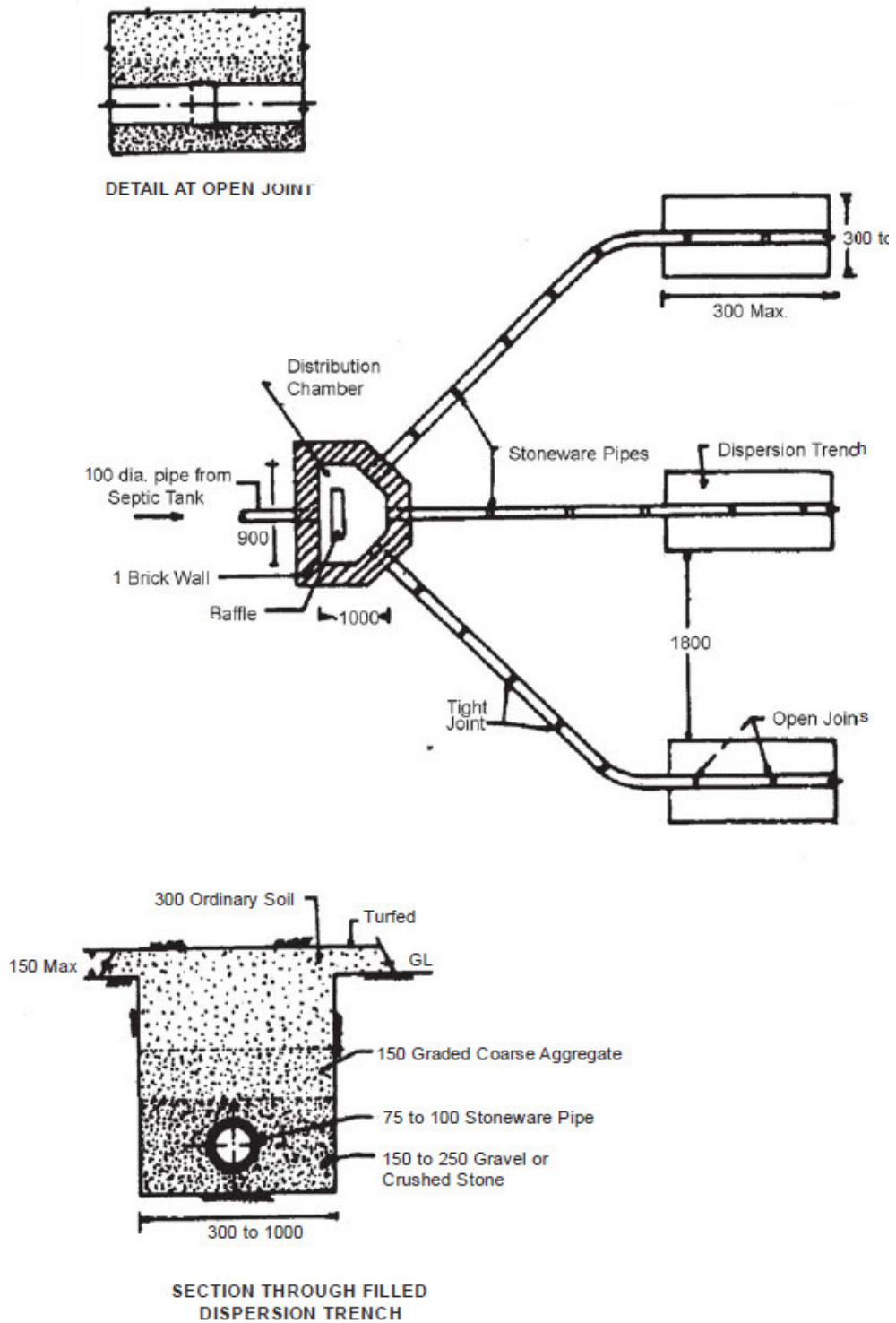
PLAN

Drawing Not to Scale  
All Dimensions are in mm

Fig. 19.17 : Soak Pit

# DISPERSION TRENCH

Sub Head : Drainage  
 Clause : 19.12

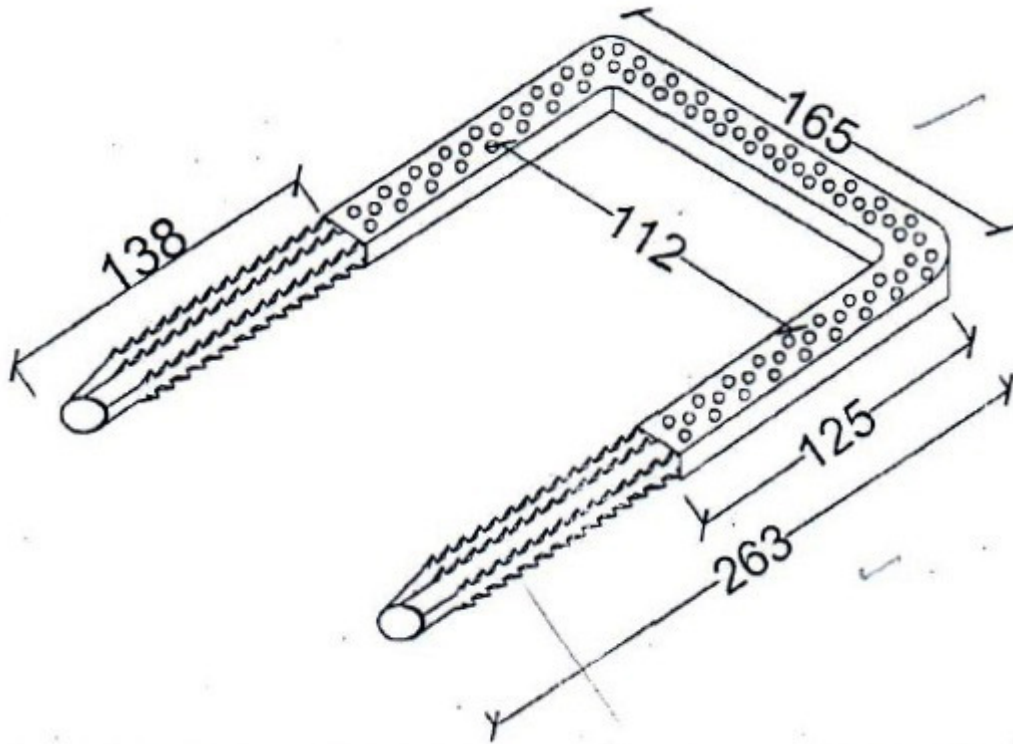


Drawing Not to Scale  
 All Dimensions are in mm

Fig. 19.18 : Dispersion Trench

**6MM THICK PLASTIC ENCAPSULATED M.S. FOOTREST AS PER IS:10910**

**Sub Head: Drainage  
Clause: 19.15**



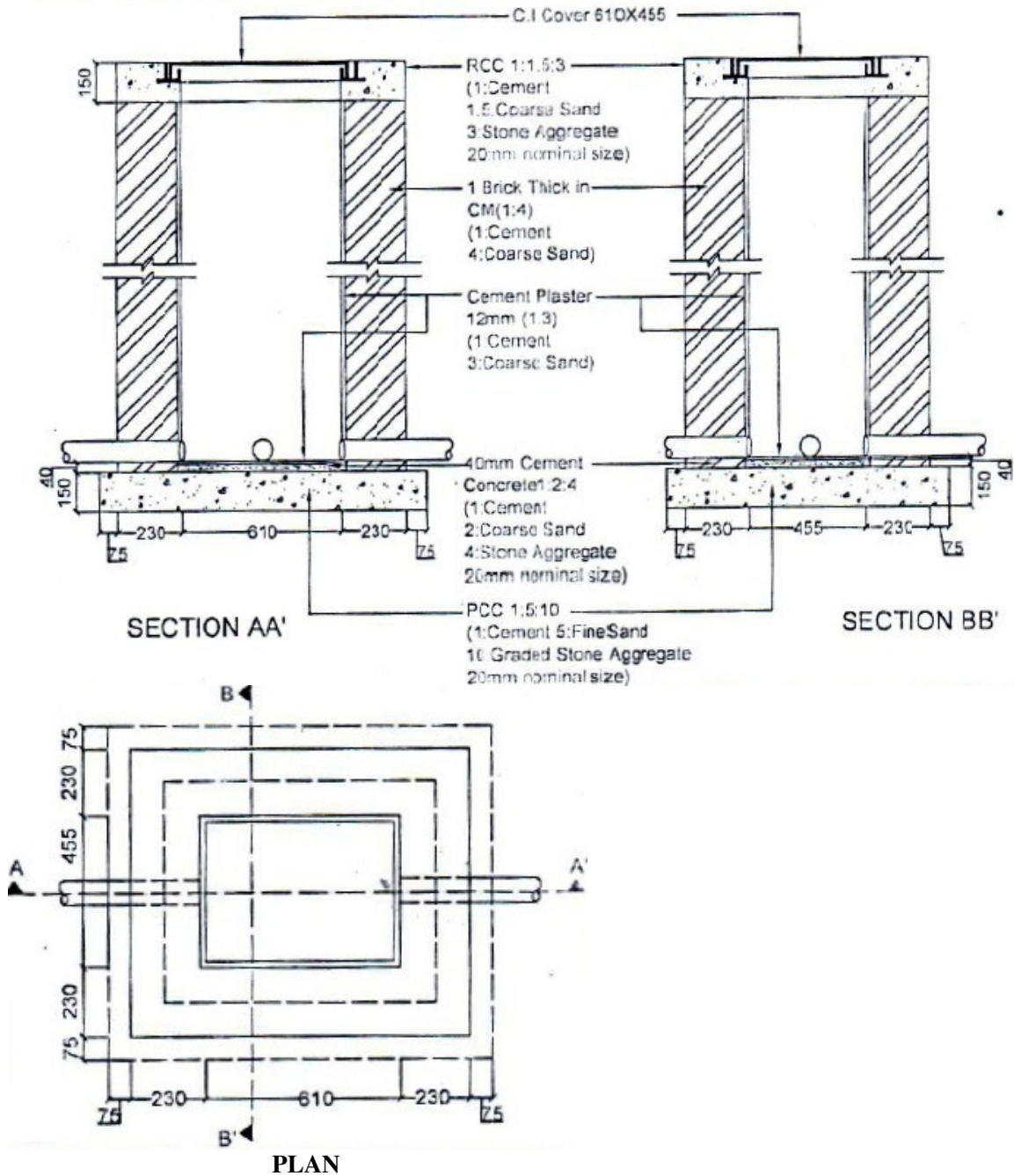
NOTE: ALL DIMENSIONS ARE IN MM  
DRAWING NOT TO SCALE

**Fig.19.19 6mm thick Plastic Encapsulated M.S. Footrest as per IS:10910**



## CHAMBER DETAILS 610X455 with Light Duty Cover

**Sub Head: Drainage  
Clause:19.18**



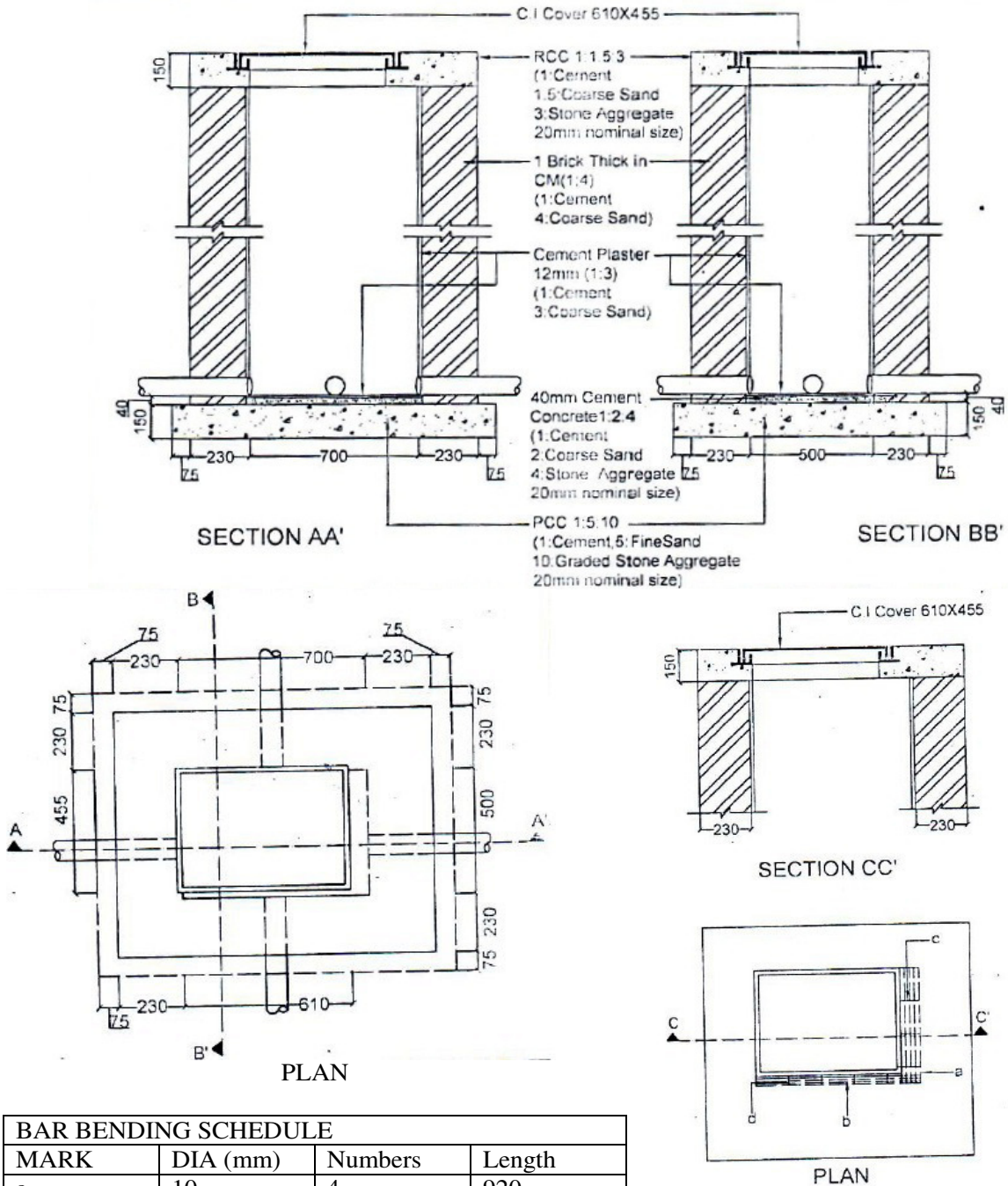
NOTE: ALL DIMENSIONS ARE IN MM  
DRAWING NOT TO SCALE

**Fig. 19.20 610X455 with Light Duty Cover**

# CHAMBER DETAILS

## 700X500 with Medium Duty Cover

Sub Head: Drainage  
Clause:19.18



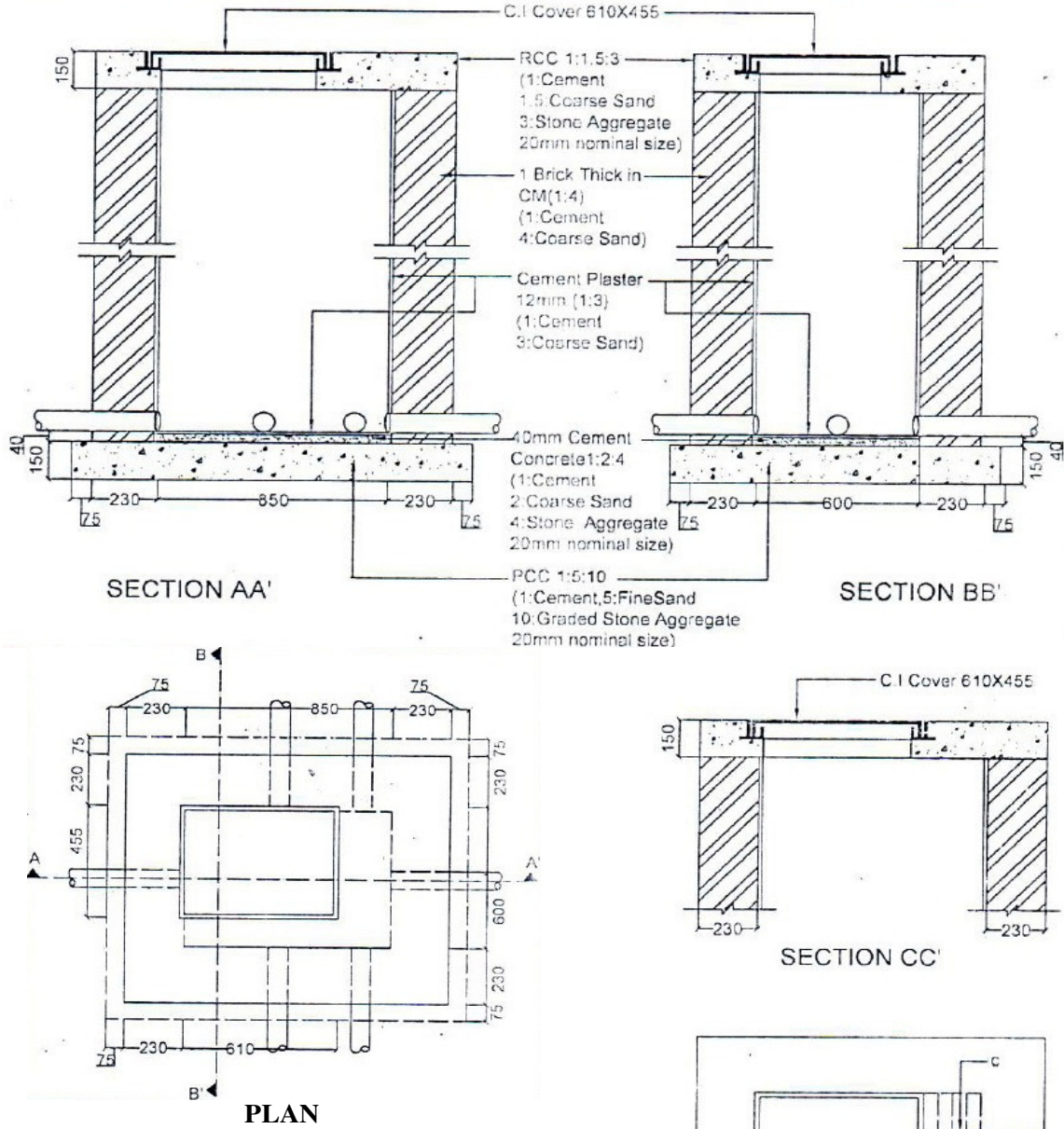
| BAR BENDING SCHEDULE |          |         |        |
|----------------------|----------|---------|--------|
| MARK                 | DIA (mm) | Numbers | Length |
| a                    | 10       | 4       | 920    |
| b                    | 10       | 3       | 1120   |
| c                    | 10       | 6       | 280    |
| d                    | 10       | 8       | 230    |

NOTE: ALL DIMENSIONS ARE IN MM  
DRAWING NOT TO SCALE

**Fig. 19.21 700X500 with Medium Duty Cover**

# CHAMBER DETAILS 850X600 with Medium Duty Cover

**Sub Head: Drainage  
Clause:19.18**



| BAR BENDING SCHEDULE |          |         |        |
|----------------------|----------|---------|--------|
| MARK                 | DIA (mm) | Numbers | Length |
| a                    | 10       | 5       | 1020   |
| b                    | 10       | 4       | 1270   |
| c                    | 10       | 6       | 430    |
| d                    | 10       | 7       | 330    |

NOTE: ALL DIMENSIONS ARE IN MM  
DRAWING NOT TO SCALE

**Fig.19.22 850X600 with Medium Duty Cover**

**SUB HEAD : 20.0**

**PILE WORK**



## CONTENTS

| <i>Clause No.</i>             | <i>Brief Description</i>   | <i>Page No.</i> |
|-------------------------------|--|-----------------|
|                               | List of Bureau of Indian Standards (BIS) Codes   | 1079            |
| 20.0                          | Terminology  | 1080            |
| 20.1                          | Driven Cast-in-situ Reinforced Concrete Piles  | 1081            |
| 20.2                          | Bored Cast-in-situ Reinforced Concrete Piles   | 1088            |
| 20.3                          | Under-reamed RCC Piles   | 1090            |
| 20.4                          | Driven Pre-cast RCC Piles  | 1097            |
| 20.5                          | Load Test on Piles   | 1104            |
| Appendix A                    | Basic Properties of Drilling Mud (Bentonite)   | 1108            |
| Appendix B                    | Equipments for Under-reamed Piles<br>(Manual Construction)                                 | 1109            |
| Appendix C                    | Pile Frame   | 1110            |
| Appendix D                    | Pile Boring Equipment-General Requirement  | 1111            |
| Appendix E                    | Cyclic Load Test Method  | 1116            |
| Appendix F                    | Pile Driving Hammer  | 1118            |
| Fig. 20.1                     | Different Types of Pile Shoes  | 1082            |
| Fig. 20.2                     | Pedestal Piles   | 1095            |
| Fig. 20.3                     | Cap for Two Piles (Typical)  | 1096            |
| Fig. 20.3.8<br>Grade Beams    | Section of interior beam in expansive soils<br>Section Of Exterior Beam In Expansive Soils | 1097            |
| Fig. D1<br>(Clause<br>20.2.2) | Pile boring equipment- general requirement   | 1112            |
| Fig. D-2                      | Sludge pump (shell)  | 1114            |
| Fig. D-3                      | Bailer   | 1114            |





### LIST OF BUREAU OF INDIAN STANDARD CODES

| <i>S. No.</i> | <i>BIS. No.</i>         | <i>Subject</i>   |
|---------------|-------------------------|--|
| 1.            | IS-1200 (Part 23)       | Method of measurement of building and Civil Engineering Works - Piling.                          |
| 2.            | IS-2911 (Part 1/Sec. 1) | Code of practice for Design and Construction of pile foundation. Driven cast-in-situ piles.      |
| 3.            | IS-2911 (Part 1/Sec. 2) | Code of practice of Design and Construction of pile foundation. Bored Cast-in-situ piles.        |
| 4.            | IS-2911 (Part 1/Sec. 3) | Code of practice for Design and Construction of pile foundation. Driven pre-cast concrete piles. |
| 5.            | IS-2911 (Part 1/Sec. 4) | Code of practice for Design and Construction of pile foundation. Bored pre-cast concrete piles.  |
| 6.            | IS-2911 (Part 3)        | Code of practice for Design and Construction of pile foundation. Under reamed piles.             |
| 7.            | IS-2911 (Part 4)        | Code of practice for design and Construction of pile foundation. Load test on piles.             |
| 8.            | IS-5112                 | Safety Code for piling and other deep foundations.   |
| 9.            | IS-6426                 | Specification for pile driving hammer.   |
| 10.           | IS-6427                 | Glossary of terms relating to pile driving.  |
| 11.           | IS-6428                 | Specification for pile frame.  |
| 12.           | IS-9716                 | Guide for lateral dynamic load test on piles.  |
| 13.           | IS-14362                | Pile boring equipments. General requirements.  |



## 20.0 PILE WORK

### 20.0 TERMINOLOGY

**Allowable Load:** It is load which is applied to a pile after taking into account its ultimate load capacity, pile spacing, Overall bearing capacity of the ground, the allowable settlement, negative skin friction including reversal of loads.

**Bearing Pile:** A pile formed in the ground for transmitting load of a structure to the soil by the resistance developed at its tips and or along its surface. It is either vertical or batter pile. It may be 'End bearing pile' or friction pile if it supports the load primarily along the surface.

**Board Compaction Pile:** It is bored cast- in-situ with or without bulb. In this compaction of surrounding ground and freshly filled concrete in pile, bore is simultaneously achieved by suitable method. A pile with a bulb is called a "under-reamed bored compaction pile". Under-reamed pile with more than one bulb is called Multi-under-reamed pile.

**Constant Rate of Penetration (CRP) Test:** The ultimate bearing capacity of preliminary piles and piles which are not used as working piles.

**Constant Rate of Uplift (CRU) Test:** The ultimate capacity in tension of preliminary piles and piles which are not used as working piles.

**Cut of Level:** It is the level where the installed pile is cut off to support the pile caps or beams.

**Datum Bar:** A rigid bar placed on immovable supports.

**Draft Bolt:** A metal rod driven into hole bored in timber, the hole being smaller in diameter than the rod.

**Drop of Stroke:** The distance through which the driving weight is allowed to fall for driving the piles.

**Factor of Safety:** It is the ratio of the ultimate load capacity of a pile to the safe load of a pile.

**Follower Tube:** A tube which is used following the main casing tube and it requires to be extended further. The inner diameter of the follower tube should be the same as the inner diameter of casing. The follower tube shall preferably be an outside guide and should be water tight when driven in water-bearing strata or soft clays.

**Initial Test:** This test is carried out with a view to determine ultimate load capacity and safe load capacity.

**Raker or Batter Pile:** The pile which is installed at an angle to the vertical. Raker piles are normally provided where vertical piles cannot resist the required applied horizontal forces. The maximum rake to be permitted in piles shall not exceed –

1 in 8 for cast-in-situ piles of large diameter viz. 750 mm dia., and above.

1 in 5 for smaller dia. cast-on-situ piles.

1 in 4 pre-cast piles.

**Routine Test:** It is carried out with a view to check whether pile is capable of taking the working load assigned to it.

**Safe Load:** It is the load arrived at by applying a factor of safety to the ultimate load capacity of the pile.

**Set:** The net distance by which the pile penetrates in the ground due to stated number of blows of the hammer.

**Spliced Pile:** A pile composed of two or more lengths secured together, end to end to form one pile.

**Test Pile:** A pile which is selected for load testing and which is subsequently loaded for that purpose. This pile may form working pile itself if subjected to a routine load test with up to one and half time the safe load.

**Total displacement (Gross):** The total movement of the pile under a given load.

**Total Elastic Displacement:** This is the magnitude of the displacement of the pile due to rebound caused at the top after removal of given test load. This comprises two components as follows:

- (a) Elastic displacement of the soil participating in load transfer; and
- (b) Elastic displacement of the pile shaft.

**Trial Piles:** These are installed initially to assess the load carrying capacity, it is either tested to ultimate bearing capacity or twice the estimated safe load.

**Ultimate Load Capacity:** The maximum load which a pile can carry before failure of ground (when the soil fails by shear) or failure of pile materials.

**Working Load:** It is a load assigned to a pile as per design.

**Working Pile:** It is a pile forming part of foundation of a structural system.

## **20.1 DRIVEN CAST-IN-SITU REINFORCED CEMENT CONCRETE PILES**

### **20.1.1 General**

Cast -in-situ piles shall be installed by driving a metal casing with a shoe at the tip and displacing the material laterally. Driven cast-in -situ pile is formed by driving a casing, permanent or temporary and subsequently filling the hole with plain or reinforced concrete.

### **20.1.2 Equipment**

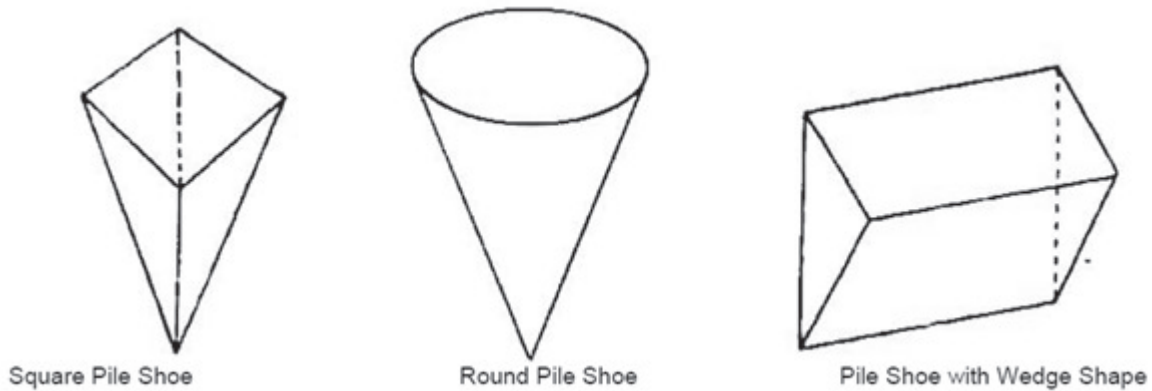
The equipment and accessories used for driven cast-in-situ piles shall depend on type of sub-soil strata, ground water conditions, type of founding material and penetration etc.

Commonly used plants are as per Appendix 'F' and few more are given below:

**Dolly:** A cushion of hardwood or some suitable material placed on the top of the casing to receive the blows of the hammer

**Kentledge:** Dead weight used for applying a test load to a pile.

**Shoe:** Pile Shoe should be of material as specified in the item. The pile shoes may be either cast iron or mild steel. Cast iron pile shoes shall be made from chill hardened iron as used for making grey iron casting conforming to IS 210. The chilled iron point shall be free from blow holes and other surface defects. Cast steel piles shoe shall be of steel conforming to IS 2644. Straps or other fastenings to cast pile shoes shall be of steel conforming to IS 1079 and shall be cast into the point to form an integral part of shoe. Different types of pile shoes are shown in Fig. 20.1



**Fig. 20.1: Different Types of Pile Shoes**

**Drop Hammer (or Monkey):** Hammer, ram or monkey raised by a winch and allowed to fall under gravity.

**Single or Double Acting Hammer:** A hammer operated by steam compressed air or internal combustion, the energy of its blows being derived mainly from source of motive power and not from gravity along.

**Pile Frame (or Pile Rig):** A movable steel structure for driving piles in the correct position and alignment by means of a hammer operating in the guides or (leaders) of the frame.

### 20.1.3 Pile Driving

**20.1.3.1 Installation of Piles:** Installation of piles shall be as accurate as possible and as per design and drawings. The **verticality** or the required batter should be correctly maintained. Particular care shall be taken in respect of installing either single pile or piles in two pile groups.

#### 20.1.3.2 Deviation /Tolerance

- (i) The deviation/tolerance should be as per IS 2911 (Part 1/Sec.1). The piles should not deviate more than 75 mm or  $D/4$  whichever is less (75 mm or  $D/10$  whichever is more in case of piles having diameter more than 600 mm) from their designed position at the working level.
- (ii) In case of a single pile under a column, the positional deviation should not be more than 50 mm or  $D/4$  whichever is less (100 mm in case of piles having diameter more than 600 mm). Greater tolerance may be prescribed for piles driven over water and for raking piles.

**20.1.3.3 Sequence of Installation:** Normal sequence of installation of pile group is from the centre to the periphery of the group or from one side to the other. Particular care shall be taken to avoid damaging the already cast pile while driving a fresh tube nearby before the concrete has sufficiently set. The possibility of the pile getting damaged is more in compact soils than in loose soils.

#### 20.1.3.4 Driving a Group of Friction Piles

- (i) The skin friction increases considerably when the pile bore is driven in the loose sand as the pile tends to compact the sand. Therefore in such cases the order of installation shall be altered so that a compact block is not created where driving further pile bore will not be possible. Similar precaution will have to be taken where stiff clay or compact sand layers will have to be penetrated.
- (ii) However driving the pile bore from centre outwards or commencing at a particular selected edge or even working across the group the problem pointed out in Para (I) above can be avoided.
- (iii) In case of very soft soil it is advisable to start driving the bore hole from outside to inside so that the soil gets restrained from flowing out during operation.

#### **20.1.3.5 Procedure of Pile Driving**

- (i) Driven cast-in-situ concrete piles are installed by driving a metal casing with a shoe at the tip/toe and displacing the material laterally.
- (ii) These piles may be cast in metal shells which may remain permanently in place or the casing may be withdrawn which may be termed as uncased driven cast-in-situ cement concrete piles.
- (iii) The metal casing shall be of sufficient thickness and strength to hold in original form and show no harmful distortion when the adjacent casing is driven and the driving core if any is withdrawn.
- (iv) Driven cast-in-situ concrete piles shall be installed using a properly designed detachable shoe at the bottom of the casing.
- (v) Any liner or bore hole; which is temporarily located and shows partial collapse that would affect the load carrying capacity of the pile, shall be rejected or repaired as directed by the Engineer-in-Charge.

**20.1.3.6** A proper record of pile driving and other details such as depth driven, sequence of installation in a group, cut off level/working level shall be mentioned in sequence of occurrence worksheet for the inspection of Engineer-in-charge.

#### **20.1.4 Jetting**

- (i) Driving of pile may be assisted by preboring holes or by the use of jets or both subject to the approval of the Engineer-in-charge. These may be used essentially to achieve the minimum penetration shown on the drawings where such penetration is not reached under normal conditions of driving. The diameter of the hole shall; not be greater than the diagonal dimension of the pile less 100 mm.
- (ii) The maximum depth of the preboring shall be such that the specified set (or less) is obtained when the toe of the pile is at founding level. Preboring shall be as approved by the Engineer-in-charge and shall not extend beyond one metre above the founding level and the pile shall be driven to at least one metre below the prebored hole. To ensure that the pile is properly supported laterally in the hole, any space remaining around the pile at the ground level after driving is finished shall be backfilled with approved granular material.
- (iii) When the water jetting is used at least two jets shall be attached to the pile symmetrically. The volume and pressure of water at the outlet nozzles shall be sufficient to freely erode material adjacent to the toe of the pile. The maximum depth of jetting shall be such that the specified set is obtained when the toe of the pile is at founding level. Jetting shall cease as directed by the Engineer-in-Charge and shall not proceed beyond one metre above the founding level and the pile shall be driven at least one metre below the prebored hole.
- (iv) To avoid very hard driving and vibration in materials such as sand, jetting of piles by means of water may be carried out in such a manner as not to impair the bearing capacity of piles already in place, the stability of the soil or the safety of any adjoining buildings. Details of arrangement for jetting shall be got approved from the Engineer-in-Charge in advance.
- (v) If large quantities of water are used for jetting it may be necessary to make provision for collection of water when it comes to the ground surface so that the stability of the piling plant is not endangered by the softening of the ground. Jetting shall be stopped before completing the driving which shall always be finished by ordinary methods. Jetting shall be stopped if there is any tendency for the pile tips to be drawn towards the pile already driven owing to the disturbance to the ground.

### 20.1.5 Reinforcement

- (i) The design of reinforcing cage varies depending upon the driving and installation conditions, the nature of the sub-soil and the nature of load to be transmitted by the shaft, axial or otherwise. The minimum area of longitudinal reinforcement of any type or grade within the pile shaft shall be 0.4 per cent of the sectional area calculated on the basis of the outside area of the casings of the shaft.
- (ii) The curtailment of reinforcement along the depth of the pile, in general, depends on the type of loading and sub-soil strata. In case of piles subjected to compressive load only, the designed quantity of reinforcement may be curtailed at appropriate level according to design requirements. For piles subjected to uplift load, lateral load & moments, separately or with compressive loads, it may be necessary to provide reinforcement to the full depth of the pile. In soft clays or loose sands, or where there is likelihood of danger to green concrete due to driving of adjacent piles, the reinforcement should be provided up to full pile depth, regardless of whether or not it is required from uplift & lateral load considerations. However, in all cases, the minimum reinforcement specified in Para (i) above should be provided in full length of the pile.
- (iii) Piles shall always be reinforced with a minimum amount of reinforcement as dowels keeping the minimum bond length into the pile shaft below its cut-off level, and with adequate projection into the pile cap, irrespective of design requirements.

**Note:** In some cases the cage may lift at bottom or at the laps during withdrawal of casing. This can be minimized by making the reinforcement “U” shaped at the bottom and up to well secured joints. Also the lifting 5 percent of the length should be considered not to affect the quality of pile.

- (iv) Clear cover to all main reinforcement in pile shaft shall be not less than 50 mm and shall be maintained by suitable spacers. The laterals of reinforcing cage may be in the form of links or spirals. The diameter and spacing of the same is chosen to impart adequate rigidity of the reinforcing cage during the handling and installation. The minimum diameter of links or spirals shall be 6 mm and the spacing of the links or spirals shall be not less than 150 mm. The minimum clear depth distance between two adjacent main reinforcement should normally be 100 mm for full depth of the cage.
- (v) The reinforcing cage should be left with adequate protruding length above the cut off level for proper embedment in the pile cap. Prior to the lowering of reinforcement cage into the pile shaft, the shaft shall be cleaned of all loose materials.
- (vi) Reinforcement in the form of cage shall be assembled with additional support, such as spreader forks and lacings; necessary to form a rigid cage hoops, links, or helical reinforcement has to fit closely around the main longitudinal bars and shall be tied by binding wire of approved quality. The ends of the binding wire shall be turned into the interior of the pile. Reinforcement shall be placed and maintained in correct position. The reinforcements shall be joined wherever necessary by welding and the procedure of welding be followed as described in IS 2751.

### 20.1.6 Concrete

**20.1.6.1 Cement :** Cement shall be as specified in agreement item or as specified under sub-head 3.0 of CPWD Specifications. However, high alumina cement shall not be used.

**20.1.6.2 Water:** Water to be used for concreting shall be as specified under sub-head 3.0 of CPWD Specifications.

**20.1.6.3 Fine Aggregate:** Fine aggregate to be used for concreting shall be as specified under sub-head 3.0 of CPWD Specifications.

**20.1.6.4 Coarse Aggregate:** For tremie concreting, coarse aggregate having nominal size more than 20 mm should not be used. Natural rounded shingle of appropriate size may also be used as coarse aggregate. It helps to give high slump with less water cement ratio.

**20.1.6.5 Chemical Admixtures:** Admixtures to be used in the concrete shall be as per IS 9103.

**20.1.6.6 Concrete Grades to be adopted**

- (i) Concreting of piles shall be done only with design mix of appropriate grade with weigh batching of constituents. The grade of concrete to be kept as per nomenclature of the item.
- (ii) Only concrete Grade M-25 and/or higher grades shall be used for concreting the piles. The exact grade of concrete to be used shall mainly depend upon the nature of work and the general design consideration. However, Concrete Grade M-15 and Grade M-20 shall not be used for concreting piles under any circumstances, even with weigh batching. The minimum cement content shall be 400 kg/m<sup>3</sup> in all conditions. **Even though cement content can be reduced by use of properly designed mixes or admixtures, but the cement content should not be less than 350 kg/cum.**
- (iii) When concreting under water or drilling mud 10 per cent additional cement over the minimum cement content for the particular grade shall be used.

**20.1.6.7 Workability of Concrete:** The minimum slump shall be 100 mm when the concrete for the piles is being vibrated and when the concrete is not vibrated the maximum permitted slump **should be 150mm to 180mm at the time of pouring.** The degree of workability in both the cases is considered as very high.

**20.1.6.8 Placing of Concrete**

- (i) Before commencement of pouring of concrete, it shall be ensured that there is no ingress of water in the casing tubes from bottom. Further, adequate control during withdrawal of the casing tube is essential so as to maintain sufficient head of concrete inside the casing tube at all stages of withdrawal.
- (ii) Wherever practicable concrete should be placed in a clean dry hole where concrete is placed in dry hole and when casing is present, the top 3 m pile shall be compacted using internal vibrators. The concrete should invariably be poured through a tremie, with a funnel so that the flow is directed and concrete can be deposited in the hole without segregation. Care shall be taken during concreting to prevent as far as possible the segregation of the ingredients. The displacement or distortion of reinforcement during concreting and also while extracting the tube shall be avoided.
- (iii) Where the casing is withdrawn from cohesive soils for the formation of cast-in-situ pile, the concreting should be done with necessary precautions to minimize the softening of the soil by excess water. Where mud flow conditions exist, the casing of cast-in-situ piles shall not be allowed to be withdrawn.
- (iv) The concrete shall be self compacting and shall not get mixed with soil, excess water, or other extraneous matter. Special care shall be taken in silt clays and other soils with tendency to squeeze into newly deposited concrete and cause necking. Sufficient head of green concrete shall be maintained to prevent inflow of soil or water into concrete. The placing of concrete shall be continuous process from the toe level to the top of pile to prevent segregation, a tube of tremie pipe as appropriate shall be used to place concrete in all piles. To ensure compaction by hydraulic static heads, rate of placing concrete in the pile shaft shall not be less than 6 m (length of pile) per hour.



- (v) The diameter of the finished pile shall not be less than specified and a continuous record shall be kept by the Engineer as to the volume of concrete placed in relation to the length of pile cast. After each pile has been cast and any empty pile hole remaining shall be protected and back filled as soon as possible with approved material.
- (vi) The minimum embedment of cast-in-situ concrete piles into pile cap shall be 150 mm. Any defective concrete at the head of the completed pile shall be cut away and made good with new concrete. The clear cover between the bottom reinforcement in pile cap from top of pile shall not be less than 30 mm. The reinforcement in the pile shall be exposed for full anchorage length to permit it to be adequately bonded into the pile cap. Exposing such length shall be done carefully to avoid damaging the rest of the pile. In cases where the pile cap is to be laid on ground a leveling course with cement concrete of Grade M-15 and of 100 mm thickness shall be provided.
- (vii) Normally concreting of piles should be uninterrupted. In exceptional case of interruption of concreting, but which can be resumed within 1 or 2 hours, the tremie shall not be taken out of the concrete. Instead it shall be raised and lowered slowly from time to time to prevent the concrete around the pipe from setting. Concreting should be resumed by introducing a little richer concrete with a slump of about 200 mm for each displacement of the partly set concrete. If the concreting cannot be resumed before final set of concrete already laid, the pile so cast may be rejected.
- (viii) In case of withdrawal of tremie out of concrete, either accidentally or to removed a choke in the tremie, the tremie may be re-introduced to prevent impregnation of laitance scum lying on the top of the concrete already deposited in the bore. The tremie shall be gently lowered on to the old concrete with very little penetration initially. A vermiculite plug should be introduced in the tremie. Fresh concrete of slump between 150 mm and 175 mm should be filled in the tremie which will push the plug forward and swill emerges out of the tremie displacing the laitance/scum. The tremie will be pushed further in steps masking fresh concrete sweep away laitance scum in its way. When the tremie is buried by about 60 to 100 cms, concreting may be resumed.
- (ix) The top of concrete in a pile shall be brought above the cut-off level to permit removal of all laitance and weak concrete before capping and to ensure good concrete at the cut-off level for proper embedment into the pile cap.
- (x) Where cut-off level is less than 1.5 metres below the working level concrete shall be cast to a minimum of 300 mm above cut-off level. For each additional 0.3 m increase in cut-off level below the working level additional coverage of 50 mm minimum shall be allowed. Higher allowance may be necessary depending on the length of the pile. When concrete is placed by tremie method concrete shall be cast to the piling platform level to permit overflow of concrete for visual inspection or to a minimum of one metre above cut off level. In the circumstances where cut-off level is below ground water level the need to maintain pressure on the unset concrete equal to or greater than water pressure should be observed and accordingly length of extra concrete above cut-off level shall be determined.

#### **20.1.6.9 Placing Concrete under Water**

- (i) Before concreting under water, the bottom of the hole shall be cleared of drilling mud and all soft loose materials very carefully. In case a hole is bored with use of drilling mud, concreting should not be taken up when the specific gravity of bottom slurry is more than 1.2. The drilling mud should be maintained at 1.5 m above the ground water level. Concreting under water for cast-in-situ concrete piles may be done either with the use of tremie method or by the use of approved method specialty designed to permit under water placement of concrete. General requirements and precautions for concreting under water are as follows:
  - (a) The concreting of pile must be completed in one continuous operation. Also for bored holes, the finishing of the bore, cleaning of the bore, lowering of reinforcement cage and concreting of pile for full length must be accomplished in one continuous operation without any stoppage.
  - (b) The concrete should be coherent, rich in cement with high slump & restricted water cement ratio.

- (c) The tremie pipe will have to be large enough with due regard to the size of the aggregate. For 30 mm aggregate the tremie pipe should be of diameter not less than 150 mm and for larger aggregate, larger diameter of tremie pipe may be necessary.
- (d) The first charge of concrete should be placed with a sliding plug pushed down the tube ahead of it to prevent mixing of water and concrete.
- (e) The tremie pipe should always penetrate well into the concrete with an adequate margin of safety against accidental withdrawal if the pipe is surged to discharge the concrete.
- (f) The pile should be concentrated wholly by tremie and the method of deposition should not be changed part way up the pile to prevent the laitance from being entrapped within the pile.
- (g) All tremie tubes should be scrupulously cleaned after use.

When concreting is carried out under water a temporary casing should be installed to the full depth of the bore hole or 2 m into non collapsible stratum, so that fragments of ground cannot drop from the sides of the hole into the concrete as it is placed. The temporary casing may not be required except near the top when concreting under drilling mud.

### 20.1.7 Testing of Concrete

**20.1.7.1** The concrete for the piles shall be sampled in accordance with the norms specified in IS 456.

The frequency of sampling is given in Table 20.1.

**TABLE 20.1**

| <i>Quantity of Concrete in the Work m<sup>3</sup></i> | <i>Number of Samples</i>   |
|---|--|
| 1-5   | 1  |
| 6-15  | 2  |
| 16-30   | 3  |
| 31-50   | 4  |
| 51 and above  | 4 plus one additional sample for each additional 50m <sup>3</sup> or part thereof. |

**Notes:**

- (i) At least one sample shall be taken from each shift.
- (ii) Where concrete is produced as continuous production unit, such as ready mix concrete plant. The frequency of sampling may be agreed upon mutually by suppliers and purchasers.

**20.1.7.2 Test Specimen:** Three test specimens shall be made for each sample for testing at 28 days. Additional samples may be required for various purposes such as to determine the strength of concrete at 7 days or to determine the duration of curing, or check the testing error, additional sample may also be required for testing samples cured by accelerated methods as described in IS 9103. The specimen shall be tested as described in IS 516.

**20.1.7.3 Test Results of Samples:** The test results of the samples shall be the average of the strength of three specimens. The individual variation should not be more than  $\pm 15\%$  percent of the average strength. If the variation is more, the test result of the sample is invalid.



### **20.1.8 Curing**

As per IS 456 – 2000, exposed surfaces of concrete shall be kept continuously in a damp or wet condition by ponding or by covering with a layer of sacking, canvas, Hessian or similar materials and kept constantly wet for at least 10 days from the date of placing concrete. The period of curing shall not be less than 14 days for concrete exposed to dry and hot weather conditions.

### **20.1.9 Defective Pile**

- (i) In case defective piles are formed they shall be removed or left in place whichever is convenient without affecting performance of the adjacent piles or cap as a whole. Additional piles shall be provided to replace them as directed.
- (ii) Any deviation from the designed location alignment or load capacity of any pile shall be noted and adequate measures taken well before concreting of the pile cap and plinth beam, if the deviations are beyond permissible limit.
- (iii) During chipping of the pile, top manual chipping may be permitted after three days of pile casting pneumatic tools for chipping shall not be used before seven days after pile casting.
- (iv) After concreting the actual quantity of concrete shall be compared with average obtained from observations actually made in the case of a few piles initially cast. If the actual quantity is found to be considerably less, special investigations shall be conducted and appropriate measures taken.

### **20.1.10 Ready Mix Concrete (RMC)**

Alternatively, the contractor can be allowed to use Ready Mix Concrete (RMC) with the permission of Engineer-in- Charge, provided that the manufacturer assures that for RMC supplied for the particular work contains the minimum cement content and it is in conformity of approved design mix. The manufacturer of RMC has also to agree to the sampling and testing procedure as specified under clause 20.1.7 or alternatively he can propose his own sampling and testing procedure which should in turn be approved by the Engineer-in -Charge. Normally, RMC supplied to site are mixed with certain admixtures which enables the concrete to be used within 3 hours of supply at site. In case RMC supplied is not consumed within 3 hours of supply the quantity of RMC remaining unused beyond 3 hours shall be rejected and removed from site.

### **20.1.11 Measurement**

Dimension shall be measured nearest to a cm. Measurement of length on completion shall be along the axis of pile and shall be measured from top of shoe to the bottom of pile cap. No allowance shall be made for bulking, shrinkage, cut off tolerance, wastage and hiring of tools and equipment for excavating driving etc.

### **20.1.12 Rate**

The rate includes the cost of materials and labour involved in all the operations described above including pile embedded in pile cap, except soil investigation, reinforcement, pile cap and grade beam.

## **20.2 BORED CAST-IN-SITU REINFORCED CONCRETE PILES**

### **20.2.1 General**

The piles are formed within the ground by excavating or boring a pile within it with or without the use of temporary casing and subsequently filling it with plain or reinforced concrete. When the casing is left permanently it is termed as cased pile and when the casing is taken out it is termed as uncased pile.

## 20.2.2 Equipment

The equipment and accessories used for bored cast-in-situ piles shall depend on subsoil strata, ground water conditions, type of founding material and penetration etc.

General requirements of boring equipment are as per Appendix 'D'. The equipment is applicable for bored piles without the use of bentonite.

**20.2.2.1** Boring operation shall be done by rotary percussion type drilling rigs using direct mud circulation or reverse mud circulation methods to bail out the cuttings or as specified. In soft clays and loose sand, bailer and chisel method should be used with caution to avoid the effect of suction. Rope operated grabbing tool Kelly mounted hydraulically operated grab are also used. This method of advancing the hole avoids suction. The size of cutting tool shall be as per [IS 2911 (Part I Section 2)] and not less than the diameter of pile by more than 75 mm.

**20.2.2.2** Use of drilling mud is stabilizing sides of bore hole where specified shall have properties as defined in Appendix A.

Permanent casing where specified shall be used to avoid aggressive action of water.

## 20.2.3 Boring for installing Pile

**20.2.3.1 Installation of Piles** : As described under clause 20.1.3.1

**20.2.3.2 Deviation and Tolerance** : As described under clause 20.1.3.2.

### 20.2.3.3 Procedure of Driving Pile Bore

- (i) Bored cast-in-situ concrete piles are installed by making a bore into the ground and removing out the material.
- (ii) The ground shall be roughly leveled and position of pile marked. The boring shall be done with or without the use of temporary casing. The sides of bore hole; shall be stabilized with the aid of temporary casing or with the aid of drilling mud of suitable consistency.
- (iii) The equipment and accessories shall depend upon the type of bored pile chosen for the job, consideration of sub-soil strata, ground water condition, type of founding material. Boring operation normally are done by rotary or percussion type drilling rigs using direct mud circulation on reverse mud tool shall be as detailed in IS 2911 (Part 1/Sec.2).
- (iv) In case permanent/temporary casing is not used then bored pile is stabilised with drilling fluid. Bentonite supplied to site shall conform to IS 2720 (Part V). A certificate shall be obtained by the contractor from the manufacturer showing properties of each consignment and should be submitted to the Engineer-in-charge. Bentonite shall be mixed thoroughly with fresh clean water to make a suspension which will maintain the stability of the pile excavation for the period necessary to place concrete and complete construction. The temperature of the water used in mixing the bentonite suspension and when supplied to bore hole shall not be lower than 5°C. Consistency of the drilling fluid suspension and when controlled throughout the boring as well as in concreting operations in order to keep the hole stabilized as well as to avoid concrete getting mixed up with thick suspension of mud.

Frequency and methods of testing drilling fluid shall be as specified and the test results shall be as specified in IS 2720 (Part V).

- (v) Bored cast-in-situ piles in soils which are stable may often be installed with a small casing length at the top. A minimum of 2.0 m length of top of bore shall; invariably be provided with casing to ensure against loose soil falling in to drilling mud, or a suitable steel casing. The casing may be left in place permanently especially in cases where the aggressive action of the ground water is to be avoided, or in the cases of piles built in water or in cases where significant length of piles could be exposed due to scour.

- (vi) For bored cast-in-situ piles, casing/liner shall be driven open ended with a pile driving hammer capable of achieving penetration of the liner to the length shown on the drawing or as directed by the Engineer-in-charge. Materials inside the casing shall be removed progressively by air lift, grap or percussion equipment or other approved means.
- (vii) Where bored cast-in-situ piles are used in soils liable to inflow, the bottom of the casing shall be kept low enough in advance of the boring tool; to prevent the entry of soil into the casing, thus presenting the formation of settlements in the adjoining ground. The water level in the casing should generally be maintained at the natural ground water level for the same reasons. The joints of the casing shall be made as tight as possible to minimize inflow of water or leakage of slurry during concreting.
- (viii) Boring shall be carried out using rotary or percussion type equipment. Unless otherwise directed by the Engineer-in-charge the diameter of the bore holes shall be not more than the inside diameter of the liner.
- (ix) After the boring has reached the required depth, the steel reinforcement shall be lowered in position maintaining the specified size of cover on all sides. The bore shall then be flushed with bentonite slurry and concreting shall be taken up exactly as described under clause 20.1.6.8.

**20.2.3.4** A proper record of pile driving and other details such as sequence of installation of piles, dimension of piles, depth bored, time taken for concreting etc. shall be maintained in sequence of occurrence at site as per clause 20.1.3.6.

While drilling mud is used, the specific gravity of fresh supply and contaminated mud in the hole before concreting is taken up shall be recorded for first ten piles and subsequently at interval of 10 piles or as specified.

#### **20.2.4 Reinforcement**

As specified under clause 20.1.5.

#### **20.2.5 Concrete**

As specified under clause 20.1.6.

#### **20.2.6 Ready Mix Concrete**

As specified under clause 20.1.10.

#### **20.2.7 Measurement**

Dimensions shall be measured nearest to a cm. Measurement of length on completion shall be along the axis of pile and shall be measured up to the bottom of pile cap. No allowance shall be made for bulking, shrinkage, cut off tolerance, wastage and hiring of tools, equipment for excavating, driving etc.

#### **20.2.8 Rate**

The rate includes the cost of material and labour involved in all the operations described above including pile embedded in pile cap except reinforcement, pile cap and grade beam.

### **20.3 UNDER-REAMED RCC PILES**

#### **20.3.1 General**

- (i) Under-reamed piles are bored cast-in-situ and bored compaction concrete types having one or more bulbs formed by suitably enlarging the bore hole for the pile stem. With the provision of bulb(s) substantial bearing or anchorage is available.

- (ii) These piles find application in widely varying situations in different types of soils where foundation are required to be taken down to a certain depth in view of considerations like the following requirements :
  - (a) To avoid the undesirable effect of seasonal moisture changes as in expansive soils.
  - (b) To reach firm strata.
  - (c) To obtain adequate capacity for downward, upward and lateral loads and moments
  - (d) To take foundations below scour level.
- (iii) When the ground consists of expansive soil e.g. black cotton soil, the bulb of the under ream pile provides anchorage against uplift due to swelling pressure apart from the increased bearing capacity.
- (iv) In case of filled up or otherwise weak strata overlying the firm strata, enlarged base in the form of under-reamed bulb in firm strata provides larger bearing area and piles of greater bearing capacity can be made.
- (v) In loose to medium pervious sandy silty strata, bored compaction piles can be used as the process of compaction increases the loads bearing capacity of the piles.
- (vi) Under- reamed piles may also be used under situations where the vibration and noise caused during construction of piles are to be avoided. The provision of bulb(s) is of special advantage in under reamed piles to resist uplift and they can be used as anchors.

### 20.3.2 Pile Grouping

- (i) For bored cast in situ under-reamed piles at usual spacing of 2 Du (**DU is bulb diameter**), the group capacity will be equal to the safe load of individual pile multiplied by the number of piles in the group. For piles at spacing of 1.5 Du the safe load assigned per pile in a group should be reduced by 10 per cent.
- (ii) In under-reamed compaction piles, at the usual spacing of 1.5 Du, the group capacity will be equal to the safe load on individual pile multiplied by the number of piles in the group.  
**Note:** In order-reamed compaction piles, the capacity of the group may be more than given in Para (i) above on account of compaction effect.
- (iii) In non-expansive soils, when the cap of the pile group is cast directly on a reasonably firm stratum it may additionally contribute towards the bearing capacity of the group.
- (iv) In load bearing walls piles should generally be provided under all wall junctions to avoid point loads on beams. Position of intermediate piles is then decided by keeping door openings fall in between two piles as far as possible.

### 20.3.3 Equipment and Other Accessories

- (i) The selection of equipment and accessories will depend upon the type of under-reamed piles, site conditions and nature of strata. Also it will depend on economic considerations and availability of manually or power operated equipment.
- (ii) A typical list of equipment for manual construction is given in Appendix B.
- (iii) Bore holes may be may be made by earth augers. In case of manual boring, an auger boring guide shall be used to keep bores vertical or to desired inclination and in position. After the bore is made to the required depth, enlarging of the base shall be carried out by means of an under-reaming tool.
- (iv) In ground with higher water table having unstable pile bores, boring and under-reaming may be carried out using suitable drilling mud. General guidelines for bentonite drilling mud are given in Appendix 'A'. In normally met soil strata, drilling mud can be poured from top while boring and under-reaming can be done by normal spiral earth auger and under-reamer.

- (v) The level of drilling mud should always be about one meter above water table or the level at which caving-in occurs. In case of very unstable strata with excessive caving-in continuous circulation of drilling mud using suitable pumping equipment and tripod, etc along with modified auger and under-reamer may be used.
- (vi) Some times permeable strata overlying a rim clayey stratum may be cased and normal boring and under-reaming operation may be carried out in clayey stratum.
- (vii) To avoid irregular shape and widening of bore hole in very loose strata at top a casing pipe of suitable length may be used temporarily during boring and concreting.
- (viii) For improved control over the inclination of batter/raker piles a tripod hoist with fixed pulley should be used for lowering in of under-reaming tools.
- (ix) For placing concrete in bore holes full of drilling mud or sub-soil water tremie pipe of not less than 150 mm diameter with flap valve at the bottom should be used.
- (x) For batter/raked under-reamed piles the reinforcement cage should be placed guiding it by a chute or any other suitable method. If concreting is not done by tremie, it should be done by chute.
- (xi) In under-reamed compaction piles, suitable device should be used for guiding the movement of drop weight and specified core assembly for its vertical driving for operating the drop weight and specified core assembly for its vertical driving for operating the drop weights of adequate capacity, suitable winch with hoisting attachment should be used.

#### **20.3.4 Pile Boring**

- (i) Under-reamed piles may be constructed by selecting suitable installation techniques at given site depending on sub-soil strata conditions and type of under-reamed piles and number of bulbs.
- (ii) In construction with equipment suggested under Appendix 'B' initially boring guide is fixed with its lower frame leveled for making desired angular adjustment for piles at batter/rake. Boring is done up to required depth and under-reaming is completed.
- (iii) In order to achieve proper under-reamed bulb, the depth of bore hole should be checked before starting under reaming. It should also be checked during under-reaming and any extra soil at the bottom of bore hole; removed by auger before reinserting the under-reaming tool.
- (iv) The completion of desired under-reamed bulb is ascertained by
  - (a) The vertical movement of the handle and
  - (b) When no further soil is cut.
- (v) In double or multi under-reamed piles, boring is first completed to the depth to the first (top) under-ream only and after completing the under-reaming boring is extended further for the second under-ream and the process is repeated.

##### **20.3.4.1 Control of Alignment**

- (i) The piles shall be installed as correctly as possible at the correct location and truly vertical (or at the specified batter/inclination). Great care shall be exercised in respect of single pile or piles in two pile groups under a column.
- (ii) As a guide for vertical piles a deviation of 1.5 per cent and for raker piles a deviation of four percent shall not normally be exceeded. In special cases, a closer tolerance may be necessary.

- (iii) Piles shall not deviate more than 75 mm or one quarter the stem diameter, whichever is less (75 mm or  $D/10$  whichever is more in case of piles having diameter more than 600 mm) from the designed position at the working level.
- (iv) In case of single pile under a column the positional deviation should not be more than 50 mm or one quarter of the stem diameter whichever is less (100 mm in case of piles having diameter more than 600 mm).
- (v) For piles where cut-off is at substantial depths, the design should provide for worst combination of the above tolerances in position and inclination.
- (vi) In case of piles deviating beyond these limits corrective measures where necessary may be taken in the form of increasing pile size, provision of extras reinforcement in the pile, redesign of pile cap and pile ties. If the resulting eccentricity cannot be taken care of by the above measures, the piles should be replaced or supplemented by; one more additional piles.

### 20.3.5 Reinforcement in Piles

- (i) The provision of reinforcement will depend on nature and magnitude of loads, nature of strata and method of installation. It should be adequate for vertical loads, lateral load and moments acting individually or in combination. It may be curtailed at appropriate depths only under the advice of the structural engineer. However, provision of reinforcement shall be as specified in drawing.
- (ii) The minimum area of longitudinal reinforcement (any type or grade) within the pile shaft should be 0.4 per cent of the sectional area calculated on the basis of outside area of shaft or casing if used.
- (iii) Reinforcement is to be provided in the full length irrespective of any other considerations and is further subject to condition that a minimum number of three 10 mm dia mild steel or three 8 mm dia high strength steel bars shall be provided. The transverse reinforcement as circular stirrups shall not be less than 6 mm dia. Mild steel bars at a spacing of not more than the stem diameter or 30 cm, whichever is less.
- (iv) For under reamed compaction piles, a minimum number of four 12 mm diameter mild steel or four 10 mm diameter high strength steel bars shall be provided.
- (v) For piles of lengths exceeding 5 m and or 37.5 cm diameter, a minimum number of six 12 mm diameter HSD bars shall be provided.
- (vi) For piles exceeding 40 cm diameter a minimum number of six 12 mm diameter high strength steel bars shall be provided.
- (vii) The circular stirrups for piles of length exceeding 5 m and diameter exceeding 37.5 cm shall be bars of 8 mm diameter.
- (viii) For piles subject to uplift loads, adequate reinforcement shall be provided to take full up lift which shall not be curtailed at any stage.
- (ix) For piles up to 30 cm diameter, if concreting is done by tremie, equivalent amount of steel placed centrally, may be provided at sides.
- (x) The minimum clear cover over longitudinal reinforcement shall be 50 mm. In aggressive environment of sulphates etc. it may be increased to 75 mm.

### 20.3.6 Concrete

**20.3.6.1 Materials :** Cement, water, fine aggregate, coarse aggregate and chemical admixtures etc. as described under clause 20.1.6.



**20.3.6.2 Concrete grades to be adopted :** Same as described under clause 20.1.6.6.

**20.3.6.3 Workability of Concrete :** Same as described under clause 20.1.6.7.

**20.3.6.4 Placing of Concrete**

- (i) Same as Para (i) to (x) under clause 20.1.6.8.
- (ii) Concreting shall be done as soon as possible after completing the pile bore. The bore hole full of drilling mud should not be left un-concreted for more than 12 to 24 hours depending upon the stability of the bore hole.
- (iii) For placing concrete in pile bores, a funnel should be used and method of concreting should be such the entire volume of the pile before is filled up without formation of voids and/or mixing of soil and drilling fluid in concrete.
- (iv) In empty bore holes for under-reamed piles a small quantity of concrete is poured to give about 100 mm layer of concrete at bottom. Reinforcement is lowered next and positioned correctly. Then concrete is poured to fill the bore hole. Care should be taken that soil is not scrapped from side if rodding is done for compaction. Vibrators shall not be used.
- (v) If water is confined up to the bucket length portion at the toe & seepage is low, the water should be bailed out and concreting should be done as prescribed in Para (iv) above.
- (vi) In case the pile bore is stabilized with drilling mud or by maintaining water head within the bore hole, the bottom of bore hole shall be carefully cleaned by flushing it with fresh drilling mud and pile bore will be checked for its depth immediately before concreting.
- (vii) Concreting shall be done by tremie method. The tremie should have a valve at bottom and lowered with valve closed at the start and filled up with concrete. The valve is then opened so permit the flow of concrete which permits upward displacement of drilling mud.
- (viii) The pouring should be continuous and tremie is gradually lifted up such that the tremie pipe opening remains always in the concrete. At the final stage the quantity of concrete in tremie should be enough so that on final withdrawal some concrete spills over the ground.  
**Note:**
  - (1) The concrete should be coherent, rich in cement (not less than 350 kg/m<sup>3</sup>) and slump not less than 150 mm.
  - (2) The tremie pipe should always penetrate well into the concrete with an adequate margin of safety against accidental withdrawal if the pipe is surged to discharge the concrete.
- (ix) In inclined piles, concreting should be done through a chute or by tremie method.
- (x) For under-reamed bored compaction piles, the pile bore is first filled up without placing any reinforcement. Concreting is done as prescribed in paras (iv) depending upon the situation. Soon after the specified core assembly shall be driven and extra concrete shall be poured in simultaneously to keep the concrete up to ground level. If hollow driving pipe is used in core assembly the pipe shall be withdrawn after filling it with fresh concrete which will be left behind.

**20.3.6.5 Estimation of Concrete Quantity**

- (i) The extra quantity required for each bored cast-in-situ under-reamed bulb of 2.5 times the stem diameter may be taken equal to a stem length of 4 to 4.5 times its diameter, depending upon the nature of strata and other site conditions. The volume of concrete actually placed shall be observed in the case of quantities of the concrete and cement for the subsequent piles.
- (ii) For under-reamed compaction piles the amount of concrete used is about 1.2 times of the under-reamed cast-in-situ piles.

**Note:** If the estimates of concrete consumption are on the volume of the bore holes and not on the basis of concrete quantity actually consumed, the concrete used may be found lesser than estimated and cement consumption may work out to be less.

**20.3.6.6 Placing Concrete under Water** : As described under clause 20.1.6.9.

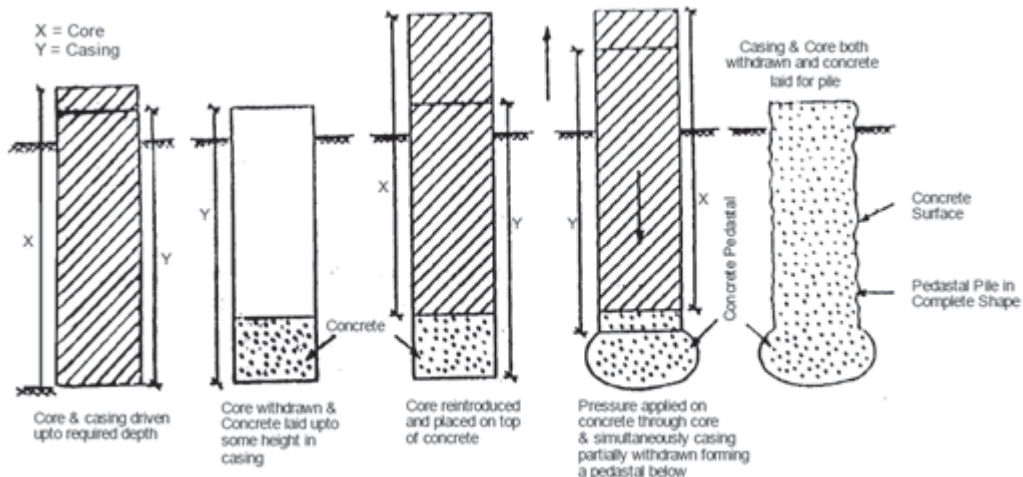
**20.3.6.7 Testing Works Concrete** : As described under clause 20.1.7.

**20.3.6.8 Curing** : As described under clause 20.1.8.

**20.3.6.9 Ready Mix Concrete (RMC)** : As described under clause 20.1.10.

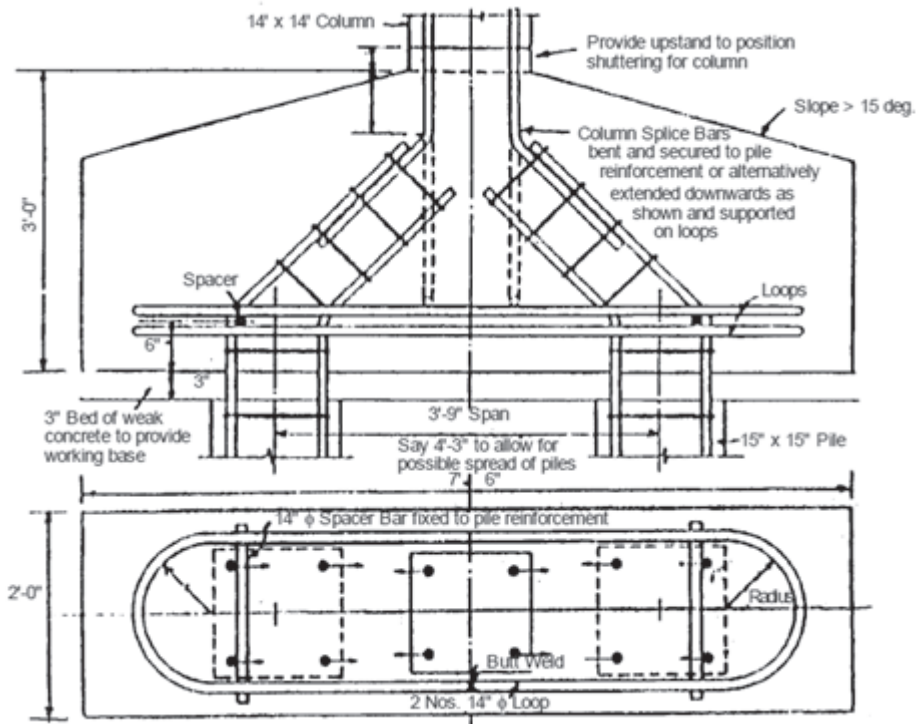
**20.3.7 Pile Cap (Fig. 20.2 and 20.3)**

- (i) Pipe cap are generally designed considering pile reaction as either concentrated loads or distributed loads. The depth of pile cap should be adequate for the shear, diagonal tension and it should also provide the necessary anchorage of reinforcement both for the column and the pile.
- (ii) The pile caps may be designed by assuming that the load from column or pedestal is dispersed at  $45^\circ$  from the top of the cap up to the mid depth of the pile cap from the based of the column or pedestal. The reaction from piles may also to be taken to be distributed at  $45^\circ$  from the edge of the pile, up to the mid depth of the pile cap on this basis, the maximum bending moment and shear forces should be worked out at critical sections.
- (iii) Full dimension of the cap shall be taken as width to analyse the section for bending and shear in respective direction. Method of analysis and allowable stresses may be according to IS 456.
- (iv) The clear overhang of the pile cap beyond the outermost pile in the group shall normally be 100 to 150 mm depending upon the size of the pile.
- (v) The cap is generally cast over a 75 mm thick leveling course of concrete. The clear cover for the main reinforcement of cap slab shall be not less than 75 mm.
- (vi) The pile should project 50 mm into the cap concrete. The design of grade beams if used shall be as given in IS 2911 (Part III).



**Fig. 20.2 : Pedestal Piles**

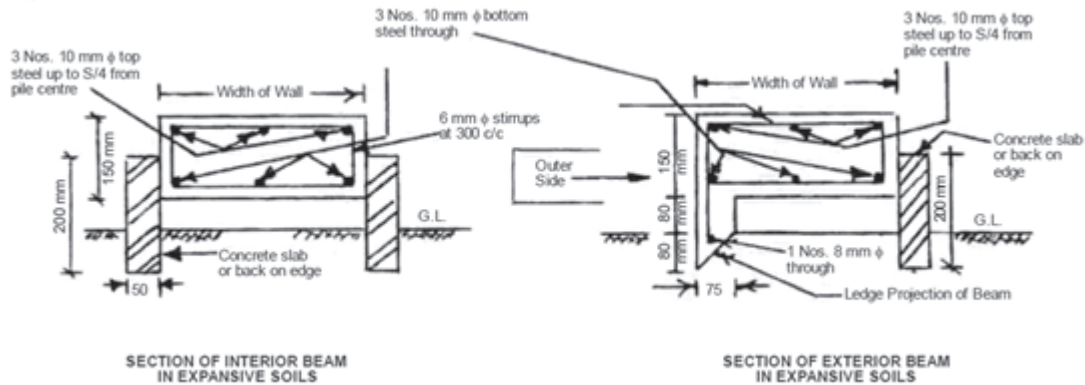




**Fig. 20.3 : Cap for Two Piles (Typical)**

### 20.3.8 Grade Beams

- (i) The grade beams supporting the walls; shall be designed taking due account of arching effect due masonry above beam. The beam with masonry due to composite action behaves as a deep beam.
- (ii) The minimum overall depth of grade beams shall be 150 mm. The reinforcement at bottom should be kept continuous in all the beams and an equal amount may be provided at top to a distance of quart span both ways from the pile centre.
- (iii) The longitudinal reinforcement both at bottom and top should not be less than three bars of 10 m diameter mild steel (or equivalent deformed steel).
- (iv) Stirrups of 6 mm diameter bars should be at 300 mm spacing which should be reduced to 100 m at the door openings near the wall edge to a distance of three times he depth of beam. No shear connectors are necessary in wall.
- (v) In expansive soil the grade beam shall be kept a minimum of 80 mm clear off the ground. In other soils, the beams may rest on ground over a leveling concrete course of about 80 mm as shown. In this case part load may be considered to be borne by ground and it may be accounted for; in the design of piles. However, the beams should be designed as usual.
- (vi) In case of exterior beams over piles in expansive soils a ledge projection of 75 mm thickness an extending 80 mm into ground as shown shall be provided on outer side beam. Typical sections of internal and external beams are shown below.



## 20.4 DRIVEN PRECAST R.C.C. PILES

### 20.4.1 General

Driven Precast Concrete Pile is a pile constructed in a casting yard and subsequently driven in the ground with or without jetting, or other technique like preboring (depending on the conditions of soil) when the pile has attained sufficient strength. By driving, the subsoil is displaced and remain in direct contact with the pile. These piles find wide application particularly for structures such as wharves, etc. to act as a free standing pile above the soil/water level or where conditions are unfavorable for use of cast-in-situ piles.

### 20.4.2 Reinforcement

- (i) The longitudinal reinforcement of specified grade and size shall be provided in the pre-cast concrete piles, for the entire length. All the longitudinal bars shall be of same length and should fit tightly in the pile shoe if the same is provided.
- (ii) Extra bars for supporting the longitudinal steel shall be provided, to resist the local bending moments but the same should be detailed in the drawings prominently so that the sudden discontinuity can be avoided. The non provision of the extra bars may lead to cracks in the pile during heavy driving.
- (iii) As per IS 2911 (Part1/Sec.3) the area of main longitudinal reinforcement shall not be less than the percentages of cross sectional area of the piles as detailed below:
  - (a) Piles with a length 30 times the least dimension: 1.25 per cent
  - (b) Piles with a length **30** to 40 times the least dimension: 1.5 per cent
  - (c) Piles with a length more than 40 times the least dimension: 2 per cent
- (iv) The lateral reinforcements, which are normally in the form of **links or spirals** of not less than **8mm** diameter TMT bars, has its own particular importance in resisting the driving stresses induced in the pile. The volume of lateral reinforcement shall not be less than the following:
  - (a) At both ends of the pile for a distance of 3 times the least width – not less than 0.6 per cent of the gross volume of pile.
  - (b) At central portions of the pile – not less than 0.2 per cent of the gross volume of pile.
- (v) The spacing of the lateral ties in a pile shall be so arranged that the concrete should have free flow around the reinforcements. The gradual transition of close spacing of lateral reinforcements near the ends to the increased spacing in the central portions of the piles should be accommodated by gradually increasing the spacing of the ties in a length of 3 times the least width of the pile.

- (vi) The cover to reinforcement should be provided to longitudinal bars. In normal conditions the cover thickness to be provided is 50 mm and in case the piles are exposed to sea water or water having other corrosive contents the minimum thickness of cover shall be 75 mm.  
**Note:** Where the concrete of pile is liable to attack of sulphates, chlorides present in ground water a minimum cover thickness of 75 mm shall be provided. In addition, the piles may be coated with some suitable material.
- (vii) Each longitudinal bar shall be in one length as far as possible, also preferably the full length bar shall be used. However, in unavoidable cases if the bars are to be joined, they shall be done by butt welding duly staggering the joints.
- (viii) The hoops or links that are to be tied to longitudinal reinforcement shall be tied with the specified type of binding wire and the free ends of the wire shall be turned into the interior of the pile.
- (ix) Preferably the hoop or link reinforcement shall be welded to the longitudinal bars so as to achieve a tight fitting.
- (x) Temporary or permanent spreader forks spaced at 1.5 m shall be used to keep the longitudinal bar in proper position and spacing.
- (xi) Before concreting, the reinforcements shall be checked by Engineer-in-charge who shall ensure that the reinforcements are tied as per approved design and drawing and shall ascertain that the tying is perfect.

#### **20.4.3 Equipment and Ancillaries**

- (i) The selection of equipment mostly depends upon the hardness of the strata. For deriving the size and weight of the pile to be handled, the most important point is the location of work.
- (ii) Generally, the following equipments are necessary for the installation of piles:
  - (a) Movable steel or timber structure duly designed to handle the pitching and driving the piles to the correct position and alignment.
  - (b) Tackles to handle piles from casting/stacking yard.
  - (c) To prevent the head of the pile from being damaged during drilling operation and to distribute the blow over the cross section of the head of the pile. A temporary steel driving cap, normally termed as 'Drive cap' is placed on the top of the pile.
  - (d) A pad, block or packing of hard wood or some suitable resilient material normally termed as "Dolly" is fixed to the upper portion of the cap (helmet) for preventing the shock from hammer on the head of the pile.
  - (e) A single acting" or "double acting" hammer is used depending on whether the hammer is allowed to fall under gravity along or is operated with the source of motive power to derive the energy.
  - (f) Sometimes it so happens that the piles are to be driven below the pile frame leaders, with the result the hammer may not be in a position to reach the pile. Under such circumstances a removable extension piece known as "follower" or "long dolly" is used to transmit the hammer blows over the pile head.
  - (g) When a particular type of soil strata is met with, the driving conditions may require equipments for jetting/pre-boring for installation of piles.
  - (h) When the piles are to be driven in rock, coarse gravel, clay with cobbles, or other soils, which may damage the tip of the pile, flat or coaxial shoes made out of steel or cast iron shall be provided at the tip of the pile.

- (i) While driving a pile in a uniform clayey soil or sandy soil no advantage can be derived by tapering the tip of the pile hence no shoe need be provided for the tip of the pile while driving piles in such soils.
- (j) When jetting is to be undertaken a jet tube may be cast into the pile by connecting the same to the pile shoe which is normally provided with jet holes. It is not advisable to provide a central which is likely to be choked.
- (k) The best results can be achieved by providing four holes in four directions. However, providing two holes in opposite direction may also serve the purpose.
- (l) Alternatively, two or more jet pies may be attached to the sides of the pile. The pile may get off loaded if proper balanced arrangement of jet is not made.

#### **20.4.4 Concrete**

**20.4.4.1 Materials:** Cement, water, fine and coarse aggregate, chemical admixtures etc. As described under clauses 20.1.6.

**20.4.4.2 Concrete Grades to be Adopted:** Same as described under clause 20.1.6.6

**20.4.4.3 Workability of Concrete:** The degree of workability in this case is “low” as the concrete is placed where the section is not heavily reinforced, also the concrete in the pile is vibrated with both internal as well as external vibrators, and therefore minimum slump should be 25 mm to 50 mm.

#### **20.4.4.4 Form-Work/Mould**

- (i) Only steel moulds manufactured out of sturdy steel sections and sheets to cast the required size of the pile are to be used. Timber moulds shall not be permitted, under any circumstances.
- (ii) The mould shall sustain the stresses generated due to the use of immersion/plate vibrators and some time even form vibrator, depending upon the size and strength of the pile to be cast.
- (ii) The manufacturing of the mould shall be so simple that the sides could be opened within 16 to 24 hours of casting by simply loosening the bolts without damaging the edges of the pile.
- (iv) Fixing supports for the sides of the mould shall be done from outside and no use of through bolts through the concrete shall be permitted to support the opposite sides of the mould.
- (v) Proper mechanism shall be introduced to fix the sides to the top of the casting platform so that the plate from vibrators can be operated without disturbing the mould.
- (vi) In case of square piles provision for forming chamfers of the pile for the corners shall be made in the mould itself.
- (vii) The mould should be such that when the pile is demoulded all the surfaces of the pile except the side from which the concrete is laid should get form finish. No rendering or finishing shall be permitted on any surface of the concrete after demoulding.
- (viii) Piles whose surfaces are plastered or rendered, edges repaired etc. shall be rejected and removed from site.
- (ix) After every casting, when the sides of the mould are opened the same shall be cleaned nicely and form oil manufactured by reputed company shall be applied over the surface before the mould is adjusted for filling the concrete, for next pile. The normal practice of applying grease mixed with diesel or waste oil instead of the form-oil shall not be permitted.

#### **20.4.5 Casting Concrete Piles (Pre-casting)**

- (i) The casting yard shall be so constructed that the piles that are cast can be lifted directly from their beds and transported to the storing yard with minimum handling and avoiding any damage to the pile.
- (ii) The casting yard shall have well drained surface so that the water used for curing the already cast piles do not accumulate on the yard inconveniencing the working on subsequent piles.
- (iii) The size of the casting platform shall be large enough to accommodate the minimum number of piles to be cast for full 11 days depending upon the proposed progress of work per day, as a pile once cast cannot be lifted from the casting bed till the expiry of ten days, therefore no piles can be cast on these spaces till the piles more than 10 days old are shifted.
- (iv) The casting yard shall be well covered not only from top but also from sides to avoid the direct sun-rays falling on the piles that are under set. The pile should also be protected from rain and wind.
- (v) Before taking up actual concreting, the moulds to be concreted for full days work shall be fixed in position and preferably moulds for concreting on the subsequent day shall also be kept ready in advance.
- (vi) If the contractor is permitted to start concrete with lesser number of moulds than that can be cast within a day, the action will prompt the contractor to open the sides of moulds already cast prematurely to continue concreting for the full day, which is not desirable as the quality of the concrete will be hampered.
- (vii) The inner faces of the mould shall be cleaned; form-oil of approved brand and manufacture shall be applied.
- (viii) The reinforcements shall be lowered carefully in the mould and fixed in position with proper cover blocks and spacers on all surfaces.
- (ix) On getting formal approval of the Engineer-in-charge for the fixing of form-work in position and on getting the pre-measurements of the reinforcements recorded, concreting with specified grade shall be taken up. The slump should be checked frequently and constant w/c ratio shall be maintained.
- (x) The piles should be cast from end to end, using immersion, form vibrators, avoiding over vibration. Proper care should be taken to see that the concrete is packed in the mould and consolidated. When the mould is full the top surface of concrete shall be neatly troweled and finished smooth.
- (xi) Proper precaution shall be taken to ensure that the vibration from the adjoining work does not affect the previously placed concrete for piles during setting period.
- (xii) On completing the concreting for a particular pile the following information shall be engraved (not painted) on each pile.
  - (1) Date of casting.
  - (2) Grade of concrete used.
  - (3) No. of lot.

The lot No. will help to locate the exact position where the particular pile has to be used.

#### **20.4.6 Testing Works Complete**

As prescribed under clause 20.1.7.

#### **20.4.7 Ready Mix Concrete**

As prescribed under clause 20.1.10.

#### **20.4.8 Curing**

- (i) Provision for curing as given under clause 20.1.8 shall be followed in addition.
- (ii) The piles shall not be lifted from the casting bed for a minimum period of 10 days from the date of casting.
- (iii) When the piles are shifted to stacking yard after the expiry of ten days, where the piles will have to be kept for a period of 28 days from the date of casting, the piles in stacks shall be covered with sacks so that the piles do not come in contact with sun rays till they attain full strength.
- (iv) Lastly, the most important factors affecting the time of curing are the method of curing, weather during hardening, probable hardness of driving and the method of lifting and pitching.
- (v) The Engineer-in-charge may fix up the exact period of curing for a particular project considering all the factors mentioned in Para (iv) above.

#### **20.4.9 Storing and Handling**

- (i) After the expiry of 10 days from the date of casting, the piles are to be removed from the casting bed and shifted to the stacking yard where the piles shall be kept for a further period of 18 days i.e. 28 days after casting and later till they are carried for driving.
- (ii) The piles shall be stored on a firm ground which will not liable for unequal subsidence or settlement under the weight of the stack of piles.
- (iii) Timber sections of suitable size shall be placed over the level ground to stack the piles on top. The spacing between the timber sections shall be so adjusted that the piles are not subjected to undue bending stresses, while in stack.
- (iv) Spaces shall be left around the piles in the stack so that they can be lifted without difficulty and necessary piles can be cured beyond 10 days.
- (v) The order of stacking the piles shall be such that the older piles can be withdrawn without disturbing the newly placed piles. Separate stacks shall be provided for the piles of different lengths.
- (vi) If ordered by the Engineer-in-Charge or if weather conditions so require arrangements for curing the piles for further period shall be made when the piles are stored in the stack.
- (vii) Care shall be taken to see that the piles are not damaged or cracked at the time of lifting, handling transportation, etc.
- (viii) While transporting the piles from the stocking yard to the site, the piles shall be supported at approximate lifting holes provided for the purpose. In case during transportation if the piles are to be unloaded temporarily they shall be placed on trestles or blocks located at the lifting points.

#### **20.4.10 Driving Piles**

- (i) Though from the consideration of maintaining the time schedule and economy in construction, the pre-cast concrete piles have to be driven without any possible delay, still it shall be kept in mind that the piles chosen for driving should be thoroughly cured and are sufficiently hard. To achieve this proper schedule shall be followed, in the operations of casting, curing, stacking and transportation of piles to site.



- (ii) The heads of the pre-cast concrete piles to be driven shall be protected with packing of resilient material against the possible damage due to the use of heavy hammers. Care shall be taken to see that packing is evenly spread and placed securely. On top of the packing a helmet should be placed and provided with a dolly of hardwood or any suitable material not thicker than the width of the pile.
- (iii) The failure in the pile may occur by compression or tension when the blow of the hammer generates the stress waves which traverse the length of the pile. Failure due to compressive stresses mostly occurs at the heads. Head stresses are independent of ground conditions and mainly depend upon the weight of the hammer, its drop and the stiffness of the head cushion.
- (iv) By using heaviest hammer and softest packing the maximum set for a given stress is obtained. The drop of the hammer however should; be adjusted to suit the allowable stress in the concrete.
- (v) Optimum driving conditions can be maintained only by regular replacement of packing materials as prescribed in Para (ii) above, since the stiffness in head packing materials increases with repeated use.
- (vi) Only in cases of exceptionally hard driving, where theoretically the compressive stresses of toe can reach twice the head stresses, failure in lower portions of the pile can occur. In practice, however, this rarely occurs as the compressive stresses to a great extent tend to be uniform over the considerable length of the pile.
- (vii) Due to reflection of compressive wave to "free end", the longitudinal tension is caused in the pile. This situation arises at a time when the ground resistance is low and/or when the hammer rebounds due to head conditions mainly because of the use of hard packing and light hammer. In addition, an unsupported long pile negotiating a hard stratum will be subjected to transverse or flexural vibrations in the pile in case the blow from the hammer becomes non-axial or if the pile is not restrained to reduce the effect of a long pile.
- (viii) For driving a pile; any type of hammer can be used provided the pile penetrates to the prescribed depth or attain the specific resistance without getting damaged.
- (ix) The hammer, helmets, dolly and the pile below should be co-axial and should sit perfectly one over the other. However, the heaviest possible hammer should preferably be used and the stroke should be so managed so as not to damage the pile.
- (x) The choice of hammer mainly depends upon whether the pile is to be driven to a given resistance or to a given depth.
- (xi) Normally, for a single acting or a drop hammer the stroke should be limited to 1.2 m but 1.0 m is preferable. Shorter stroke may be used in cases where there is a danger of damaging the pile, a few examples of which are described below:
  - (a) Hard surface has to be penetrated in the early stages when a long pile has to be driven.
  - (b) When there is a soft ground up to a considerable depth, a large penetration is achieved at each blow.
  - (c) The pile suddenly reaches refusal when it meets with rock or other virtually impenetrable soil.
- (xii) If a satisfactory set is achieved for ten consecutive blows with an appropriate hammer and drop the method of driving should be repeated with caution and long continued driving. However, after the pile has almost ceased to penetrate the driving should be stopped especially when the hammer with moderate weight is used.
- (xiii) Sometimes it so happens that the rate of penetration suddenly changes without any satisfactory reasoning or soil conditions. Under such circumstances the pile driving should not be continued till real problem is investigated and remedy thought over.

#### **20.4.10.1 Jetting with Driving Pile**

- (i) The jetting operation is effective only in the cohesion less soils such as sand, gravel and fine grained soils with very less percentage of clay. The jetting will be ineffective in clay soils.
- (ii) The main purpose of jetting is to minimize or almost eliminate the resistance at the toe and last the same time the frictional resistance along the surface of the pile shaft also gets reduced.
- (iii) Very hard driving and vibrations can be avoided when the toe resistance is eliminated and also the rate of penetration is increased considerably when compared to the normal driving methods without jetting.
- (iv) Jetting operations shall be carried out only when specifically ordered by the Engineer-in-Charge. Jetting shall be carried in a manner that the stability of soil and the bearing capacity of piles already driven is not in any way impaired. Similarly, the safety of the adjoining structures shall be taken into consideration.
- (v) For effective jetting the quantity of water required is directly related to the cross sectional area of the piles (including external jet pipes). In dense cohesion less soils the quantity of water up to 2 litres per minutes per sq.cm. of pile cross section may be required. Less quantity of water may be needed in loosely compacted soils.
- (vi) The water pressure to be maintained is between 5.6 kgf/cm<sup>2</sup> to 10.6 kgf/cm<sup>2</sup> or more. In case large quantities of water are used the draining arrangement for the water that emerges on the ground shall have to be made otherwise the stagnant water may soften the ground endangering the piling equipment resting above.
- (vii) To minimize the risk of blockages, the nozzle should not be positioned at the point of the toe. The arrangement of jets should be balanced to ascertain the penetration of the pile vertically. It is advisable to surge down an independent pile or two pipes may be attached to the opposite sides of the pile for effective jetting operation.
- (viii) The pile shall be allowed to enter the ground gradually after operating the water under the weight of pile and the hammer. Acceptable verticality may be achieved by use of rigid leaders, duly controlling the rate of penetration with a pile winch.
- (ix) On achieving maximum apparent penetration with light driving by the method prescribed above and when the water jets are running the further penetration may be attained in the cohesion less soils. The piles shall be driven to the final position or set when the jetting is complete.
- (x) Before closing the driving operation, the jetting should be stopped and the driving shall be continued by ordinary driving methods. If due to the ground disturbances, the pile tips tend to be drawn towards the piles already driven, jetting should be stopped immediately.
- (xi) The correct working of jets should be tested before the work on driving the pile is commenced. If the pile is not provided with as "built in jet arrangement" independent jet pipes down the outside the pile can be used and to achieve the best result jets working on several faces of the pile can be practical which will also assist maintaining the verticality.

#### **20.4.10.2 Stripping Pile Heads**

- (i) Stripping of pile shall be done in such a manner that a minimum 50 mm length of pile projects into the pile cap. Sufficient length of reinforcement from the pile shall be exposed for embedding the same inside the pile cap.
- (ii) The stripping operation or exposing the reinforcement of the pile shall be done very carefully without damaging the pile proper. In case any portion of the concrete cracks, the defective portion shall be cut and the portion repaired with new concrete joining properly with old concrete.



### **20.4.10.3 Lengthening Piles**

- (i) Sometimes the length of a pile has to be increased either before or during driving; this can be done by casing additional concrete over the old pile. In such cases the original head of the pile is cut to expose minimum 200 mm length of bar.
- (ii) The exposed steel should be cleaned properly and shall be held in firm position, while full penetration butt welding is done.
- (iii) In case the conditions on site are not favorable to attempt butt welding, a minimum length of 40 d (40 times the diameter of main bar) of the original pile shall be exposed and the new steel should be overlapped over the exposed steel. The overlap shall be spot welded.
- (iv) On completion of welding/overlapping the reinforcement and tying the spirals, for the extended length of reinforcements the extras portion of the pile can be concreted thus extending the original pile.

### **20.4.11 Risen Piles**

- (i) Sometimes due to ground heave there is a possibility that piles already driven to the final depth may start rising when adjacent piles are being driven; such rising shall be noted at frequent intervals till driving on adjacent piles is in progress.
- (ii) On completion of driving the adjacent piles, the piles that are risen shall again be driven back either to their original level or up to a point of resistance.

### **20.4.12 Pile Cap**

As per clause 20.3.7.

### **20.4.13 Grade Beam**

As per clause 20.3.8.

### **20.4.14 Measurement**

Dimension shall be measured nearest to a cm. Measurement of length on completion shall be along the axis of pile and shall be measured from top of shoe to the bottom of pile cap No allowance shall be made for bulking, shrinkage, cut off tolerance, wastage and hiring of tools, equipment for excavating and driving etc.

### **20.4.15 Rate**

The rate includes the cost of materials and labour involved in all the operations described above including pile embedded in pile cap, centering, shuttering except reinforcement, pile cap and grade beam.

## **20.5 LOAD TEST ON PILES**

### **20.5.1 General**

The bearing capacity of a single or group of piles shall be determined from test loading. It is most direct method for determining safe load on pile and it is more reliable on account of its being in-situ test. The load test on a concrete pile shall not be carried out earlier than 28 days of its casting. Initial test shall be carried on test pile which is not used as working pile and Routine tests shall be carried out as a check on working pile. Routine test shall be one-half percent to two percent of total number of piles or as specified, applicable to vertical and lateral load. Load Test shall generally conform to provision made in IS 2911 (Part IV) which provides guidelines for determination of safe loads and conducting of different types of tests.

### 20.5.2 Types of loadings/tests

- (i) Vertical Load Test (Compression)
- (ii) Cyclic Vertical Load Test
- (iii) Lateral Load Test

### 20.5.3 Vertical Load Test

**20.5.3.1 General:** Compression load shall be applied to the pile top by means of a hydraulic jack against suitable load frame which is capable of providing reaction and settlement is recorded by suitable dial gauges. The contractor shall apprise of Engineer-in-Charge before test is conducted.

**20.5.3.2 Preparation of Pile Head:** Pile head shall be chipped off to horizontal plane, projecting steel shall be cut or bent and top finished smooth and leveled with plaster of Paris or similar synthetic material as specified to give a plane surface which is normal to the axis of the pile. A bearing plate with a hole at the centers shall be placed on the head of pile for the jacks to rest.

**20.5.3.3 Loading Platform:** A proper loading platform is installed as specified. Contractor shall ensure that when the hydraulic jack and load measuring devices are mounted on pile head the whole system will be stable on the maximum specified load. For single pile two dial gauges shall be fixed to the pile and bear on surfaces on reference frame. The dial gauges shall be placed in diametrically opposite positions and be equidistant from the pile axis. Four dial gauges are used for groups, having 0.01 mm sensitivity. The arrangement shall be approved by the Engineer-in-charge.

**20.5.3.4 Application of Load:** The test is carried out by applying a series of downward incremental load (20 per cent of safe loads on pile). In this method application of increment of test load and taking of measurement or displacement in each stage is maintained till the rate of displacement is either 0.1 mm in first 30 minutes or 0.2 mm in first one hour or 2 hours, whichever occurs first. The test load shall be maintained for 24 hours. This method is applicable for both initial and routine test. For testing of raker piles the loading shall be along its axis. Safe load on single pile for initial test is least of following:

- (i) Two-thirds of the final load at which the total displacement attains a value of 12 mm unless otherwise stated **based on type of structure**, in such case the safe load should be corresponding to total displacement permissible.
- (ii) 50 per cent of the final load at which the total displacement equal 10 per cent of pile diameter and 7.5 per cent of bulb diameter in case of under-reamed piles.

Routine test shall be carried for a test load of one and half times the working load, maximum settlement not to exceed 12 mm or as stated.

Safe load on group of piles for initial test shall be least of the two

- (i) Final load at which total displacement is 25 mm or as stated based on type of structure.
- (ii) Two-thirds of final load at which the total displacement is 40 mm.

Routine test shall be carried for a test load equal to not less than working load, the maximum settlement not to exceed 25 mm.

**20.5.3.5 Maintained Load Method:** This is applicable for both initial and routine test. In this method application of increment of test load and taking of measurement or displacement in each stage of loading is maintained till rate of displacement of the pile top is either 0.1 mm in first 30 minutes or 0.2 mm in first one hour or till 2 hours, whichever occurs first. If the limit of permissible displacement as given in 20.5.3.4 is not exceeded, testing of pile is not required to be continued further. The test load shall be maintained for 24 hours.

Pile test data such as load, displacement and time shall be recorded in suitable prescribed tabular form. Results can be presented by suitable curves.

Test shall be carried out in proper manner and to the entire satisfaction of the Engineer- in- charge. After the test is completed the test cap shall be dismantled and pile surface shall be resorted to original shape.

**20.5.3.6 Measurement:** Each completed test shall be enumerated for initial test, routine test separately.

**20.5.3.7 Rate:** The rate includes the cost of labour, material and all the operations described above such as preparatory work including installation of loading platform, applying load, preparing pile head for load test, trimming of pile head etc. complete.

#### **20.5.4 Cyclic Vertical Load Testing**

**20.5.4.1 General:** This process shall be used in case of initial test to find out separately skin friction and point bearing load on single piles of uniform diameter in conformity of provisions of IS Code 2911 (Part 4) for conducting of the test.

**20.5.4.2 Preparatory Pile Head:** As per clause 20.5.3.2.

**20.5.4.3 Loading Platform:** As per clause 20.5.3.3

**20.5.4.4 Application of Load:** Relevant provision as per clause 20.5.3.4 shall be applicable. The test may be continued up to 50 per cent over the safe load.

**20.5.4.5** Test procedure given in Appendix E shall be followed.

Test shall be carried out in proper manner and to the entire satisfaction of the Engineer-in-charge.

After the test is completed, the test cap shall be dismantled and pile surface shall be restored to original shape.

**20.5.4.6 Measurement:** Each completed test shall be enumerated for different load ranges.

**20.5.4.7 Rate:** The rate includes the cost of labour, materials and all the operations described above such as preparatory work, trimming of pile head etc. complete.

#### **20.5.5 Lateral Load Testing**

**20.5.5.1 Load Platform:** A proper loading platform shall be installed as specified. Hydraulic jack is mounted with gauge between two piles or pile groups under test. Dial gauge tips shall rest on central portion of glass plate fixed on the side of pile.

**20.5.5.2 Application of Load:** Full load imposed by the jack shall be taken as lateral resistance on each pile or group. Load should be applied in increments of about 20 per cent of the estimated safe load. The next increment shall be applied after the rate of displacement is approximately equal to 0.1 mm per 30 minutes.

**20.5.5.3** The safe lateral load on pile; is least of the following:

- (i) Fifty per cent of the final load at which total displacement increases to 12 mm.
- (ii) Final load when total displacement is 5 mm.
- (iii) Load corresponding to any other specified displacement as per **performance** requirement.

Pile group shall be tested as per actual conditions as far as possible.

**20.5.5.4 Displacements:** Displacement is read by at least two dial gauges of 0.1 mm sensitivity spaced at 30 cm and kept horizontally one above the other and displacement is interpolated at cut off level. One dial gauge placed diametrically opposite to jack shall directly measure displacement. Where, it is not possible to locate one of the dial gauges in the line of the jack axes, then two dial gauges may be kept at a distance of 30 cm at a suitable height and the displacement interpolated at load point from similar triangles.

**Note:** One of the methods of keeping dial gauge on pile surface is to chip off uneven concrete on the side of the pile and to fix a piece of glass 20 to 30 mm square. The dial gauge tips shall rest on the central portion of the glass plate.

Arrangement and test procedure shall be duly approved by the Engineer-in-Charge.

**20.5.5.5 Measurement:** Each completed test shall be enumerated for different load ranges.

**20.5.5.6 Rate:** The rate includes the costs of labour, materials and all the operations described above.

**BASIC PROPERTIES OF DRILLING MUD (BENTONITE)**

*[Clause 20.2.2.2 & 20.3.3 (iv)]*

**A- 1 Properties**

**A-1.1** The bentonite suspension used in bore holes is basically clay of montmorillonite group having exchangeable sodium cat ions. Because of the presence of sodium cat-ions, bentonite on dispersion will break down into small plate like particles having a negative charge on the surfaces and positive charge on the edges. When the dispersion is left to stand undisturbed, the particles become oriented building up a mechanical structure at its own. This mechanical structure held by electrical bond is observable as a jelly like mass or jell material. When jelly is agitated, the weak electrical bonds are broken and the dispersion becomes fluid.

**A-2 Functions**

**A-2.2** In the case of granular soil, the bentonite suspension penetrates into the sides under positive pressure and after a while forms a jelly. The bentonite suspension gets deposited on the sides of the hole not penetrate into the soil, but deposits only a thin film on the surface of the hole. Under such condition, stability is derived from the hydrostatic head of the suspensions.

**A-3 Specification**

**A-3.1** The bentonite suspension used for pilling work shall satisfy the following requirements:

The liquid limit of bentonite when tested in accordance with IS 2720 (Part V) **1985** shall be **400 percent or more.**

- (a)
- (b) The sand content of the bentonite powder shall not be greater than 7 per cent.  
**Note:** The purpose of limiting the sand content is mainly to control and reduce the wear and tear of the pumping equipment.
- (c) Bentonite solution should be made by mixing it with fresh water using pump for circulation. The density of the bentonite solution should be **between 1.03 to 1.10 gm/ml.**
- (d) The mash viscosity when tested by a Marsh cone should be **between 30 and 60 stoke.**
- (e) The swelling index as measured by the swelled volume after 12 hours in abundant quantity of water shall be at least 2 times its dry volume.
- (f) The pH value of the bentonite suspension shall **be between 9 and 11.5**

**EQUIPMENTS FOR UNDER-REAMED PILES (MANUAL CONSTRUCTION)**

*(Clause 20.3.3)*

**B-1 Equipment**

**B-1.1** Normally the following equipment will be required in manual operation:

- (a) An auger;
- (b) An under-reamer;
- (c) A boring guide; and
- (d) Accessories like spare extensions, cutting tool, concreting funnel etc.

**B-1.1.1** For the piles of size larger than 30 cm and for larger depths additional equipment required will be portable tripod hoist with a manually operated winch.

**B-1.1.2** For piles in high ground water table and unstable soil conditions, boring and under-reaming shall be carried out with bentonite slurry using suitable equipment. Tremie pipe shall be used for concreting

- (a) Drop weight for driving the core assembly, and
- (b) Pipe or solid core.

## PILE FRAME

### Scope

Specification for pile frame shall be in conformity to the one laid in IS 6428. Contractor shall use the proper height of pile frame and which is able to take the weight of hammer safely.

Standard size of pile frame will assist the user in determining the type and size of frame. Damaged pile frame which cannot be used for want of spares shall be replaced with sound one.

### Size

The size of pile frame shall be designated by its height and the weight of the hammer and the pile it can take.

The pile frame shall be as per the sizes given in table below:

| S.No | Size | Height of Pile Frame | Weight of hammer | Weight of pile (Any Type) max |
|------|------|----------------------|------------------|-------------------------------|
| 1    | I    | 7.5                  | 1.5              | 3                             |
| 2    | II   | 10.5                 | 3                | 6                             |
| 3    | III  | 15                   | 5                | 10                            |
| 4    | IV   | 20                   | 6                | 12                            |
| 5    | V    | 25                   | 6                | 12                            |

**Extension Panels:** All pile frames shall be capable of being fixed with extension panels of 1.5, 3 and 4.5 m height without reduction in weight capacity.

**Performance:** Pile frames with or without extension panels shall be capable of placing piles at the maximum backward rake in 1 in 5 and the maximum forward rake 1 in 10.

**PILE BORING EQUIPMENT- GENERAL REQUIREMENT**  
**(Clause 20.2.2)**

**Scope**

Specification for pile boring equipment shall be as per IS 14362. Constructions of bored piles require careful selection of boring equipment. Choice of appropriate equipment will depend upon subsoil conditions, diameter of pile, their depths and other specific requirements of any particular work. Details of equipment and proposed methods of driving the pile shall be submitted by the tenderer for scrutiny and approval by the competent authority

Equipment described herein refers to construction of bored piles on land and without the user of bentonite. The standard nominal diameter of piles shall be 450 mm, 500 mm, 600 mm and the like.

**Materials**

All materials used in the construction of pile boring equipment shall conform to the requirement of relevant Indian Standard IS 800 'Code of Practice' for general construction in steel.

**Pile Boring Equipment****General**

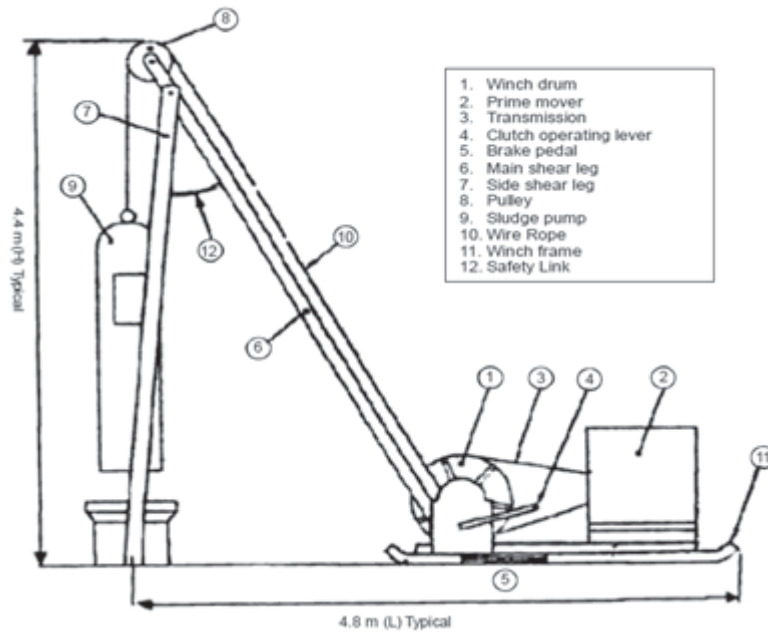
The various items comprising pile boring equipment are:

- (a) Winch
- (b) Derrick
- (c) Boring/chiseling tools
- (d) Temporary casings
- (e) Tremie arrangements, and
- (f) Accessories

A typical piling winch consists of the following components as shown below in Fig. D1

- (a) Winch drum,
- (b) Prime mover,
- (c) Transmission system,
- (d) Clutch system,
- (e) Brake system,
- (f) Winch





**Fig. D1**

**Winch Drum:** This standard capacities (drum rope pull) of the winch drum shall be 5 t. And the drum meter shall not be less than 20 times the diameter of the wire ropes used.

**Prime Mover:** The prime mover shall usually be a diesel engine of the air cooled type or an electric motor. A suitable reduction gear shall also be provided.

**Transmission:** The transmission system shall be one of the following :

- (a) Geared drive
- (b) Chain drive, and
- (c) Belt drive (flat belt or V-belt)

The transmission system shall be provided with suitable guard cover.

**Clutch System:** The clutch system shall consist of a clutch wheel and friction plate(s) or a Friction cone operated by a lever.

**Brake System:** This shall consist of a brake band connected with the foot brake pedal or brake handle for hand operation.

**Winch Frame:** A typical winch frame shall be made from structural steel section and shall be either truck -mounted crawler-mounted or skid-mounted. A proper stabilizer shall be provided to transmit the load to the ground smoothly.

### **Derrick**

**General:** The standard derrick shall consist of the following components:

- (a) Main shear leg,
- (b) Side shear leg,

- (c) Shear leg base,
- (d) Pulley, and
- (e) Safety link.

The hoisting capacity of the derrick shall be at least equal to the maximum drum rope pull and preferably more by 25%.

**Main Shear Leg:** The main shear leg shall be a box section fabricated according to IS 800-1984 either from two mild steel angle sections or two channel sections. The box section shall have minimum dimensions of 125 mm<sup>2</sup> and the minimum length of the leg shall be 5.6 m.

**Side Shear Legs:** The two sides shear legs shall have a minimum box section of 100 mm<sup>2</sup>. One of the two side legs shall be provided with suitable mild steel rings spaced 0.3 m apart up to the top. These legs shall be placed part at as distance of minimum of 3 m.

**Shear Leg Base:** These shall consist of a steel plate welded to the base of the leg. Additional plates shall be welded on all four sides of the leg for up to 15 mm above the bottom of the leg.

**Pulley:** The pulley shall be usually provided at the top of the main shear-leg and it shall have a diameter at least 20 times the diameter of the wire-rope used. The pulley shall have a suitable guard and shall be properly lubricated.

**Safety Link:** An interconnected steel -chain shall be provided near the top of the derrick so as to preclude any accidental increase in the distances between the legs.

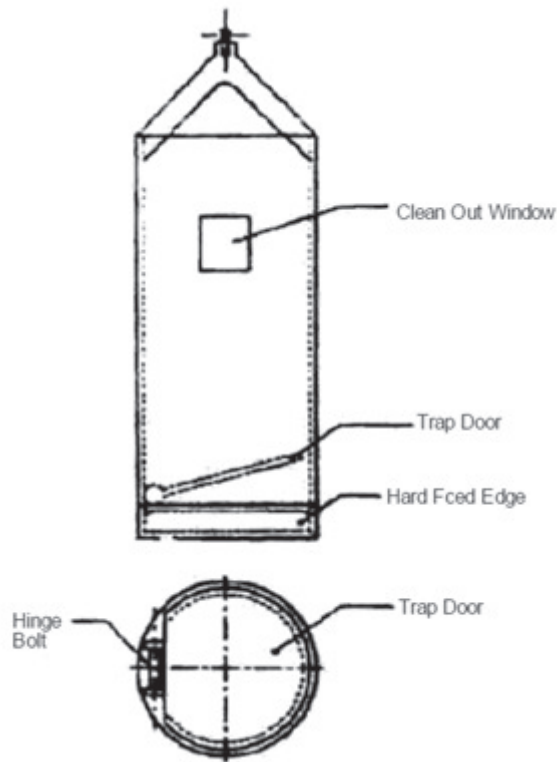
#### **Boring/Chiseling Tools**

The various tools shall be as follows:

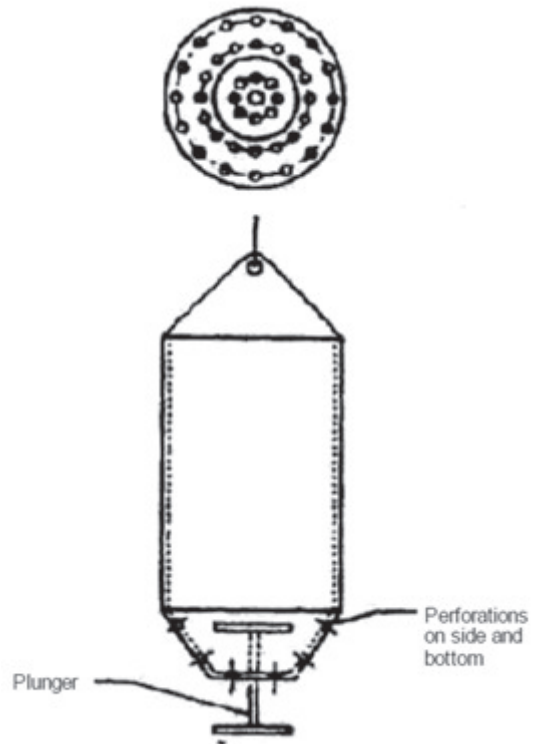
- (a) Sludge pump,
- (b) Bailers,
- (c) Chisels,
- (d) Casings,
- (e) Casing extractor plate,
- (f) Casing extractor bar,
- (g) Casing drive bar, and
- (h) Tiller

**Sludge Pump:** Boring shall be usually advanced by using a sludge pump (also called shell) as shown in Fig. D-2. Weight of the sludge pump shall vary with the diameter but normally minimum weight shall be 7.5 kN. Sludge pump is a hollow cylindrical steel body with a cutting shoe at the bottom and a lifting hook at its top. It has a hinged trap door immediately above the bottom cutting edge and it has an opening (window) near the top for muck removal. Above this window, lead or steel or concrete may be added to increase the weight of the sludge pump for effective boring.

**Bailer:** The bailer (see Fig. D -3) is used for removal of water or slush from the bore hole. It is made up of a hollow steel cylinder with a lifting hook at the top and a truncated base plate with perforation at the bottom. There is a plunger passing through a central hole of the base plate which acts as a plug valve. This plunger is about 20 cm long and has about 15 cm diameter steel plates welded at its top and bottom. This closes the central hole in the base plate of the plunger and thus retains the slush material for removal.



**Fig. D-2 : SLUDGE PUMP (SHELL)**



**Fig. D-3 : BAILER**

**Chisels:** Hard strata during boring shall be broken by chisels. The chisels shall be made of solid round bar with hard faced edged at the bottom. The chisel shall weigh at least 7.5 KN for 450 mm 12.5 KN for 500 and 600 mm piles.

**Casing:** These shall be made from 16 mm thick plates and the standard length shall be 1.5 m. The casings shall be threaded on both sides and suitable collar shall be used to protect the threads.

**Casing Extractor Plate:** A steel plate of suitable size shall be used for the extraction casing after the boring operation is complete.

**Casing Extractor Bar:** This shall be a round of about 75 mm diameter. It shall be passed through the holes on the sides of the casing and through the extractor plate, to enable extraction of casing.

**Casing Drive Bar:** This shall have a cross-section of at least 75 mm<sup>2</sup> and shall be used to drive the casing.

**Tiller:** This gadget shall be used to rotate the casing manually, whenever necessary.

#### **Temporary Casing**

This shall consist of the following.

The casing collar shall be attached at the casing top to take the blows during casing driving.

The main casing shall be made from 16 mm thick steel and shall be threaded at one end.

The casing shall be provided with a cutting edge at the bottom to facilitate driving.

**Tremie Arrangements**

The tremie arrangements shall include the Following:

- (a) Concrete hopper
- (b) Hopper plug
- (c) Tremie pipe
- (d) Holding clamp and
- (e) Hoisting plug.

**Accessories**

Accessories shall include the following:

- (a) Concrete placer
- (b) Wheel barrow
- (c) Measuring chain
- (d) Bailers
- (e) Crowbars
- (f) Dog-clamps with pins
- (g) Steel measuring tape; and
- (h) Mucking shovel.

**CYCLIC LOAD TEST METHOD**  
(*Clause 20.5.4.5*)

**E-1 Method**

**E-1.1** Alternate loading and unloading shall be carried out at each stage as in 20.5.3.5 and each loading stage shall be maintained as in 20.5.5.2 and each unloading stage shall be maintained for at least 15 minutes and the subsequent elastic rebound in the pile should be measured accurately by dial gauges as in 20.5.5.5. The test may be continued up to 50 per cent over the safe load.

**E-2 Analysis of Results for Frictional Resistance****E-2.1 Graphical Method**

**E-2.1.1** Assuming that there is no compression in the pile, plot a graph relating total elastic recovery and load at the pile top.

**E-2.1.3** Draw a straight line parallel to the straight portion of curve I to divide the load into two parts and thereby obtained approximate values of point resistance and skin friction.

**E-2.1.4** From the approximate value of skin friction, and knowing the loads of top of pile, compute the elastic compression of the pile corresponding to these loads, by the following formula:

$$= \frac{(T-F/2)L}{AE}$$

Where

= Elastic compression of pile in cm, T = Load on pile top in kgf,

F = Frictional resistance in kgf, L = Length of the pile in cm,

A = Cross-sectional area of the pile in cm<sup>2</sup>, and

E = Modulus of elasticity of the pile material in kgf/cm<sup>3</sup>

(The value should normally be measured from an exposed portion of pile stem by means of compress meter during the load test itself.)

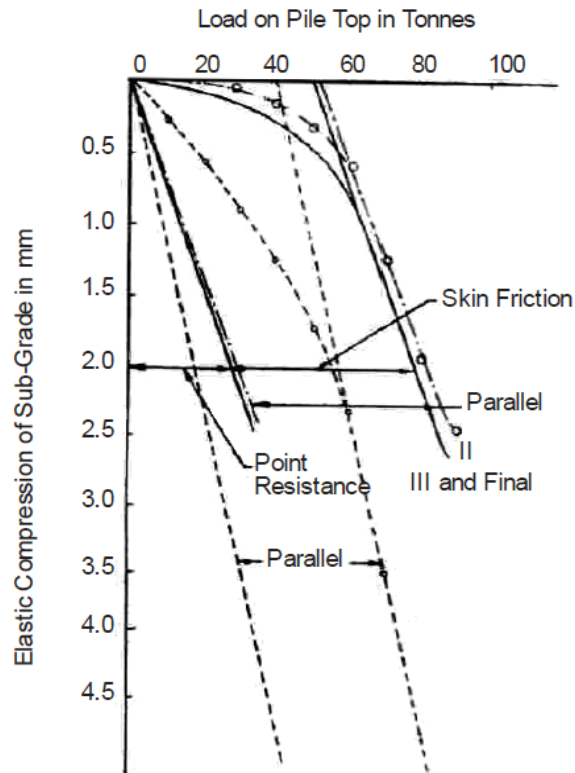
**E-2.1.5** Obtain values of the elastic compression of the sub grade by subtracting the elastic compression of the pile from the total elastic recovery of pile, and plot the graph relating these new values the negative value shall be ignored until the value is positive.

**E-2.1.6** Repeat the procedures given in E-2.1.3 to obtain new values of skin friction.

**E-2.1.7** The process of further approximations covered in E-2.1.6 may be repeated further to any desired extent, but usually the third curve would give sufficiently accurate values for skin friction for practical purposes.

## E-2.2 Analytical Method

### Analysis of Cyclic Load Test Data for Separation of Skin Friction and Point Resistance.



**E-2.2.1** From straight line portion of curve calculate the value of constant from the equation.

$$m = \frac{s - (T/AE)L}{T}$$

Where

$m$  = A constant;

$\Delta_s$  = Change in total elastic settlement of pile

$\Delta T$  = Change in applied load =  $(T_b - T_a)$  in kgf

$L$  = length of pile in cm;

$A$  = cross-sectional area of pile in  $\text{cm}^2$

$E$  = elastic modulus of the material of pile in  $\text{kgf/cm}^2$

$T$  = Load on pile top in kgf.

**E-2.2.2** Calculate the corrected settlement for different load increment by equation (2)

$$S = mT$$

Where

$S$  = Corrected settlement in cm, and

$T$  = Total load on pile top in kgf.

**E-2.2.3** Knowing value of  $m$  and  $S$  compute skin friction and point bearing by solving simultaneous equation (3) and (4).

$$T = P + F$$

$$S = mP + \frac{(T-F)L}{AE}$$

Where

$P$  = point bearing in kgf, and

$F$  = skin friction in kgf.

## PILE DRIVING HAMMER (Clause 20.1.2)

### Scope

Specifications for driving hammer shall be in conformity to the one laid in IS 6426. Driving hammer of standard weight and strokes of different types be used.

The object should be to keep weights of hammers to a limited range and standardize weight interval and stroke to facilitate their use with piling rig & piling attachments of different plants.

Piles may be driven with any type of hammer, provided they penetrate to the prescribed depth or attain to ensure a final penetration of not more than 5 mm per blow.

### Classification

It is preferable to employ the heaviest hammer practicable and to limit the stroke, so as not to damage the pile. Pile hammers shall be classified as given in the Table below:

| Table No. | Classification of Pile Driving Hammers |                         |
|-----------|--|-------------------------|
| S. No.    | Class                                  | Weight Kg               |
| (1)       | (2)                                    | (3)                     |
| (i)       | Light Hammers                          | Up to 500               |
| (ii)      | Medium Hammers                         | Over 500 and up to 2500 |
| (iii)     | Heavy Hammers                          | Over 2500               |

### Sizes

The recommended sizes (weight of ram or striking part) and stroke of different types shall be as given in Table below:

**TABLE**  
**Sizes (Weight of Ram or the Striking Part) and Stroke of Different Types of Hammers**

| S.No. | Type of Hammers  | Light (upto 500 kg)   | Medium<br>9Over 500 up to 2500 kg)   | Heavy (Over<br>2500 kg)   |
|-------|--|---|--|---|
| (1)   | (2)  | (3)   | (4)  | (5)   |
| 1     | Drop Hammer  | 250 to 500 kg at multiples of 125   | 750 to 2500 kg at multiples of 250   | 2750 to 4500 kg at multiples of 250                                 |
| 2     | Single acting capable of working on steam or air at 5.5 kg/cm <sup>2</sup> at the hammer | (a) 25 to 100 kg at multiples of 25 kg at maximum stroke of 20 cm<br>(b) 100 to 500 kg at multiples of 100 kg at maximum stroke of 40 cm. | 750 to 2500 kg at multiples of 250, at maximum stroke of 90 cm.            | 3000 to 7500 kg at multiples of 500 kg at maximum stroke at 120 cm. |
| 3     | Double acting capable of working on steam or air at 5.5 kg/cm <sup>2</sup> at the hammer | (a) 25 to 100 kg at multiples of 25 kg at maximum stroke of 20 cm<br>(b) 100 to 500 kg at multiples of 100 kg at maximum stroke of 25 cm. | 750 to 2500 kg at multiples of 500, at maximum stroke of 45 cm.            |   |
| 4     | Diesel Hammer  | 500 kg at maximum stroke of 250 cm  | Over 500 up to 2500 kg at multiples of 500 kg at maximum stroke of 250 cm. |   |

**SUB HEAD : 21.0**

**ALUMINIUM WORK**





## CONTENTS

| <i>Clause No.</i> | <i>Brief Description</i>                                       | <i>Page No.</i> |
|-------------------|--|-----------------|
|                   | List of Bureau of Indian Standards (BIS) Codes                 | 1125            |
| 21.0              | Terminology  | 1126            |
| 21.1              | Aluminium  | 1127            |
| 21.2              | Paneling Material  | 1128            |
| 21.3              | EPDM Gaskets   | 1132            |
| 21.4              | Sealant  | 1132            |
| 21.5              | Reflective Glass   | 1133            |
| 21.6              | Door, Window, Ventilator and Partition Frames                  | 1134            |
| 21.7              | Door, Windows and Ventilator Shutters                          | 1135            |
| 21.8              | Fittings   | 1153            |
| 21.9              | Louvers  | 1153            |
| 21.10             | Hermetically Sealed Unit                                       | 1153            |
| 21.11             | Brass Lock   | 1154            |
| 21.12             | Machine moulded Aluminium covering over expansion              | 1154            |
| 21.13             | Anodised Aluminium Grill                                       | 1155            |
| 21.14             | 12mm Thick Frameless Toughened Glass Door Shutter              | 1156            |
| 21.15             | Non Sag Elastomeric Polyurethane Sealant                       | 1157            |
| Fig. 21.1         | Terminology for Aluminium Doors, Windows and Ventilators       | 1135            |
| Fig. 21.2         | Types and Size of Aluminium Doors, Windows and Ventilators     | 1136            |
| Fig. 21.3         | Extruded Aluminium Sections for Doors, Windows and Ventilators | 1137            |

|            |   |      |
|------------|---|------|
| Fig. 21.4  | Location of Parts of Aluminium Doors, Windows and Ventilators for which Details are Shown | 1140 |
| Fig 21.5   | Mullion with Fixed Glass on one Side and Side Hung on Other Side                          | 1141 |
| Fig 21.6   | Mullion with Side Hung Shutter Both Sides   | 1141 |
| Fig 21.7   | Coupling Section Extruded for Coupling Windows Side by Side                               | 1141 |
| Fig 21.8   | Detail Through Bottom of Top-Hung Ventilator  | 1141 |
| Fig 21.9   | Coupling Section Extruded having Weather Bar Fitted with Ventilators on top of Windows    | 1141 |
| Fig 21.10  | Weather Bar over Extruded Opening Shutter with Fixed Light Above                          | 1142 |
| Fig 21.11  | Detail of Aluminium Double Shutter Door   | 1142 |
| Fig. 21.12 | Typical Projecting Type Hinge for Side-Hung Shutters                                      | 1143 |
| Fig. 21.13 | Typical Non-Projecting Type Hinge for Side-Hung Shutters                                  | 1144 |
| Fig. 21.14 | Illustration Showing Working Principle of Friction Stay                                   | 1144 |
| Fig. 21.15 | A Typical Handle for Side-Hung Shutter  | 1145 |
| Fig. 21.16 | Position of Handle Plates in Relation to Heights of 'HS' Type Windows                     | 1145 |
| Fig. 21.17 | A Typical Peg-Stay for Side-Hung Shutters and Top-Hung Ventilators                        | 1145 |
| Fig. 21.18 | Detail Through Jamb Showing Turnbuckle  | 1146 |
| Fig. 21.19 | Typical Rotor Operator for Side-Hung Shutters Fitted with Fly Screens                     | 1146 |
| Fig. 21.20 | Detail of Horizontal Centre-Hung Ventilator   | 1147 |
| Fig. 21.21 | Spring Catch for Centre-Hung Ventilator   | 1147 |
| Fig. 21.22 | Cord Eye and Pulley Arrangement for Centre-Hung Ventilator                                | 1147 |

|            |  |      |
|------------|--|------|
| Fig. 21.23 | Typical Projecting Type Hinge for Door                                       | 1148 |
| Fig. 21.24 | Typical Non-Projecting Type Hinge for Door                                   | 1148 |
| Fig. 21.25 | Typical Door Handle  | 1149 |
| Fig. 21.26 | Typical Vertical Bolt for Double Shutter Door                                | 1149 |
| Fig. 21.27 | Typical Three-Way Bolting Device for Doors                                   | 1150 |
| Fig. 21.28 | Coupling Section Extruded for Coupling Door to Window or Side Light          | 1150 |
| Fig. 21.29 | Chart Showing Approximate Position of Fixing Holes and Number of Fixing Lugs | 1151 |



### LIST OF BUREAU OF INDIAN STANDARD (BIS) CODES

| <i>S. No.</i> | <i>BIS. No.</i> | <i>Subject</i>  |
|---------------|-----------------|---|
| 1.            | IS 733          | Wrought Aluminium and Aluminium Alloys, Bars, Rods and Sections (For General Engineering Purposes) -Specification                 |
| 2.            | IS 737          | Wrought Aluminium and Aluminium alloy sheet and strip for general engineering purposes -Specification                             |
| 3.            | IS 1285         | Wrought Aluminium and Aluminium Alloy, Extruded Round Tube and Hollow sections (For General Engineering Purposes) - Specification |
| 4.            | IS 1868         | Anodic coating on Aluminium and its Alloys-Specification  |
| 5.            | IS 1948         | Specification for Aluminium Doors, Windows and Ventilators  |
| 6.            | IS 3908         | Specification for Aluminium equal leg angles  |
| 7.            | IS 3909         | Specification for Aluminium unequal leg angles  |
| 8.            | IS 3965         | Dimensions for wrought Aluminium and Aluminium Alloys bars, rods and sections.  |
| 9.            | IS 5523         | Method of testing anodic coating on aluminium and its alloys.   |
| 10.           | IS 6012         | Measurement of coating thickness by Eddy Current Method   |
| 11.           | IS 6315         | Floor springs (Hydraulically regulated) for heavy doors-Specifications  |
| 12.           | IS 6477         | Dimensions of extruded hollow section and tolerances  |
| 13.           | IS 12823        | Wood products- Pre-laminated particle board -Specifications.  |
| 14.           | IS 14900        | Transparent Float glass- Specifications.  |

## 21.0 ALUMINIUM WORK

### 21.0 TERMINOLOGY

#### **Bar**

Any solid section, other than round, with at least one dimension of 10 mm or more.

#### **Rod**

Any round solid section with a diameter of 10 mm or greater.

#### **Extruded Round Tube**

A circular hollow extrusion of uniform wall thickness not subjected to cold drawing.

#### **Hollow Section**

An extruded shape other than round tube, the cross section of which completely encloses a void or voids and which is not subject to cold drawing.

#### **Anodized Aluminium**

Aluminium with an anodic coating, produced by an electrolytic oxidation process, in which the surface of the aluminium is covered with a coating, generally an oxide, to give protective and decorative properties.

#### **Pre-laminated Particle Board**

A particle board laminated on both surface by synthetic impregnated base papers under the influence of heat and pressure with finished foil under the pressure or pressure and heat depending on type of binder used.

#### **Floor Spring (Hydraulically Regulated)**

A device used to close the door so as to slow down its speed before it reaches its closed position.

#### **Single Action Floor Spring (Hydraulically Regulated)**

A device used to close the door in one direction only so as to slow down its speed before it reaches to its closed position.

#### **Double Action Floor Spring (Hydraulically Regulated)**

A device used to close the door in both directions so as to slow down its speed before it reaches its closed position.

#### **Shoe**

The device fixed to the bottom of the door leaf in order to hoist it to the floor spring.

#### **Top Centre Pivot**

The device to secure the upper portion of the door leaf and the door frame above.

#### **Right Hand Floor Spring**

A floor spring suitable for use on an anticlockwise door; an anticlockwise door is one which when viewed from above, rotates in anticlockwise direction about its hinge while opening.

#### **Left Hand Floor Spring**

The floor spring suitable for use on clockwise door a clockwise door is one which, when viewed from above, rotates in clockwise direction about its hinge while opening.

#### **Sash**

It is a complete window unit whether fixed or open type.

## **Composite Window**

Window unit having two or more sashes joined together with one or more coupling members.

## **Centre – Hung Ventilator**

A ventilator horizontally pivoted at the centre on both sides. Top half opens inwards and bottom half opens outwards.

## **21.1 ALUMINIUM**

### **21.1.1 Aluminium Sections**

Aluminium sections used for fixed/openable windows, ventilators, partitions, frame work & doors etc. shall be suitable for use to meet architectural designs to relevant works and shall be subject to approval of the Engineer-in- Charge for technical, structural, functional and visual considerations. The aluminium extruded sections shall conform to IS 733 and IS 1285 for chemical composition and mechanical properties. The stainless steel screws shall be of grade AISI 304.

The permissible dimensional tolerances of the extruded sections shall be as per IS 6477 and shall be such as not to impair the proper and smooth functioning/operation and appearance of door and windows.

Aluminium glazed doors, windows etc. shall be of sizes, sections and details as shown in the drawings. The details shown in the drawings may be varied slightly to suit the standards adopted by the manufacturers of the aluminium work, with the approval of Engineer-in-Charge. Before proceeding with any fabrication work, the contractor shall prepare and submit, complete fabrication and installation drawings for each type of glazing doors, windows, ventilators and partition etc. for the approval of the Engineer-in- Charge. If the sections are varied, the contractor shall obtain prior approval of Engineer-in-Charge and nothing extra shall be paid on this account.

### **21.1.2 Anodising**

Standard aluminium extrusion sections are manufactured in various sizes and shapes in wide range of solid and hollow profiles with different functional shapes for architectural, structural glazing, curtain walls, doors, window & ventilators and various other purposes. The anodizing of these products is required to be done before the fabrication work by anodizing/electro coating plants which ensures uniform coating in uniform colour and shades. The extrusions are anodized up to 30 micron in different colours. The anodized extrusions are tested regularly under strict quality control adhering to Indian Standard.

### **21.1.3 Powder Coating**

**21.1.3.1 Material:** The powder used for powder coating shall be Epoxy/polyester powder of make approved by the Engineer- in-Charge. The contractor shall give detailed programme for powder coating in advance, to facilitate the inspection by Engineer-in-Charge or his authorized representative.

**21.1.3.2 Pre-treatment:** Each aluminium alloy extrusion or performed section shall be thoroughly cleaned by alkaline or acidic solutions under the conditions specified by chemical conversion coating supplier and then rinsed. A chemical conversion coating shall be applied by treatment with a solution containing essentially chromate ions or chromate and phosphate ions as the active components as applicable. The amount of the conversion coating deposited depends on the type used by the conversion coating chemical supplier. The conversion coating shall be thoroughly rinsed either with the solution specified by the conversion coating chemical supplier or with de-mineralized water and then dried at the temperature for the time specified by the conversion coating chemical supplier. The contractor shall submit the detail specifications and application procedure for application of conversion coating for approval of Engineer- in-Charge. The metal surface after the conversion coating pretreatment and prior to the application of the coating shall be free from dust or powdery deposits.



**21.1.3.3 Process:** The polyester powder shall be applied by electrostatic powder spray method. Before start of powder coating the contractor shall submit detail specification for application of polyester powder from manufacturer of the polyester powder for approval of Engineer-in-Charge. The powder coating shall be applied as per the specification approved by Engineer-in-Charge.

**21.1.3.4 Thickness:** The thickness of the finished polyester powder coating measured by micron meter shall not be less than 50 micron nor more than 120 micron at any point.

**21.1.3.5 Performance Requirements for the Finish**

- (i) *Surface appearance:* The finish on significant surfaces shall show no scratches when illuminated and is examined at an oblique angle, no blisters, craters; pinholes or scratches shall be visible from a distance of about 1 m. There shall not be any visible variation in the colour of finished surfaces of different sections and between the colours of different surfaces of same section.
- (ii) *Adhesion:* When a coated test piece is tested using a spacing of 2 mm between each of the six parallel cuts (the cut is made through the full depth of powder coating so that metal surface is visible) and a piece of adhesive tape, approximately 25 mm x 150 mm approved by the Engineer-in-Charge is applied firmly to the cut area and then removed rapidly by pulling at right angles to the test area, no pieces of the finish other than debris from the cutting operation shall be removed from the surface of the finish.

**21.1.3.6 Protection of Powder Coated / Anodizing Finish :** It is mandatory that all aluminium members shall be wrapped with self adhesive non-staining PVC tape, approved by Engineer-in-Charge.

**21.1.3.7 Measurement:** All the aluminium sections including snap beading fixed in place shall be measured in running meter along the outer periphery of composite section correct to a millimeter. The weight calculated on the basis of actual average (average of five samples) weight of composite section in kilogram correct to the second place of decimal shall be taken for payment. (Weight shall be taken after anodizing). The weight of cleat shall be added for payment. Neither any deduction nor anything extra shall be paid for skew cuts.

**21.1.3.8 Rate:** The rate shall include the cost of all the materials, labours involved in all the operations as described in nomenclature of item and particular specification.

**21.2 PANELING MATERIAL**

**21.2.1 Pre-laminated Particle Board**

A particles board laminated on both surfaces by synthetic resin impregnated base papers under heat and pressure. Pre -laminated particle boards shall be of two grades, namely, Grade I and II corresponding to IS 3087 & 12823. Each of the grades specified shall be of four types, namely, Types-I, II, III, and IV classified by the surface abrasion characteristics specified in Table 21.1. The grade and types of pre-laminated particle board shall be represented by symbols as follows:

| <i>Grade</i> | <i>Type</i> | <i>Designation</i> |
|--------------|-------------|--------------------|
| Grade 1      | Type I      | PLB-11             |
|              | Type II     | PLB-12             |
|              | Type III    | PLB-13             |
|              | Type IV     | PLB-14             |
| Grade 1      | Type I      | PLB-21             |
|              | Type II     | PLB-22             |
|              | Type III    | PLB-23             |
|              | Type IV     | PLB-24             |

**TABLE 21.1**  
**Physical and Mechanical Properties**  
(Para 21.2.1)

| Sl. No. | Properties   | Flat Pressed Three Layer, Multilayer and Graded |          |
|---------|--|---|----------|
|         |  | Grade-I   | Grade-II |
| (i)     | Density variation (Max.) Percent                                   | ± 10  | ± 10     |
| (ii)    | Water absorption (Max )  |   |          |
|         | (a) 2 hours  | 7.0   | 15.0     |
|         | (b) 24 hours   | 15.0  | 30.0     |
| (iii)   | Thickness swelling (Max.), percent, 2 hours                        | 5.0   | 8.0      |
| (iv)    | Modulus of rupture (Min) N/mm <sup>2</sup>                         |   |          |
|         | (a) Up to 20 mm thickness  | 15.0  | 11.0     |
|         | (b) Above 20 mm thickness  | 12.5  | 11.0     |
| (v)     | Tensile strength perpendicular to surface (Min.) N/m <sup>2</sup>  |   |          |
|         | (a) Up to 20 mm thickness  | 0.45  | 0.3      |
|         | (b) Above 20 mm thickness  | 0.4   | 0.3      |
| (vi)    | Tensile strength perpendicular to surface (Min.) N/mm <sup>2</sup> |   |          |
|         | (a) After cyclic test*   | 0.2   | -        |
|         | (b) After accelerated water resistance test**                      | 0.15  | -        |
| (vii)   | Screw withdrawal strength (Min.), N:                               |   |          |
|         | (a) Face   | 1250  | 1250     |
|         | (b) Edge   | 850   | 750      |
| (viii)  | Abrasion resistance (Min.) in number of revolutions                |   |          |
|         | (a) Type I   | 450   | 450      |
|         | (b) Type II  | 250   | 250      |
|         | (c) Type III   | 80  | 80       |

\* *Cyclic Test* : Specimen are immersed in water at 27±2° C for a period of 72 hours, followed by drying in air at 27 ± 2° C for 24 hours and then heating in dry air at 70° C for 72 hours. Three such cycles are to be followed and then specimens are tested for tensile strength perpendicular to the surface.

\*\* *Accelerated Water Resistance Test*: Specimens are immersed in water at 27±2° C and water is brought to boiling and kept at boiling temperature for two hours. Specimens are then cooled in water to 27±2° C and tested for tensile strength perpendicular to the surface.

**21.2.1.1 Particle Board:** Synthetic resin bonded flat pressed three layers, multilayer and graded particle board defined in IS 3087 having superfine surface shall be used for production of prelaminated particle board. For ECO Marks the particle board shall also conform to the requirements of ECO Mark specified in IS 3087.

**21.2.1.2 Impregnated Base Paper:** Printed or plain coloured absorbent base paper having a weight of 60 -140 g/m<sup>2</sup> impregnated in a suitable synthetic resin and dried to a volatile content of 4-8 per cent shall be used for pre-lamination on both surfaces of particle board.

**21.2.1.3 Impregnated Overlay:** An absorbent tissue, paper having a weight of 18-40 g/m<sup>2</sup> impregnated in a suitable synthetic resin and dried to a volatile content of 4-8 per cent shall be used for the manufacture of pre-laminated particle board.

**21.2.1.4 Manufacture:** Particle boards having superfine and closed surface with high face strength and steep density gradient across the thickness is used for making prelaminated particle boards. Impregnated base papers rich in a synthetic resin are placed on either side of the particle board and the assembly is taken inside a short cycle single opening lamination press or a multi day light press. Under heat and pressure the resin flows and forms a permanent bond with particle board.

The top surface of impregnated paper comes in contact with special surface chromium plates or steel caul plates and takes the impression of surface finish of these cauls. Hot boards are extracted out of the short cycle press and cooled in air, whereas cooling of boards is done inside the press in multiday light type. Care should be taken to keep cycle times low in the press to avoid heat penetration to the centre of the board edge.

The impregnated overlay paper may be used by placing it over the impregnated base paper (IBP) on one surface while using a normal IBP on the other surface and pressure. The impregnated overlay becomes transparent after pressing. Such boards are used for high surface abrasion application.

In case of finished foil particle boards, the finished foil is pasted on both surfaces of particle board after spreading suitable synthetic glue on board's surface and passing the assembly in a roller press or a flat press under the influence of pressure and/or heat depending on the type of binder used.

**21.2.1.5 Finish:** The finish of the paper overlaid board depends on the surface of caul plates used. Common surface finishes in use are glossy, matt textured (soft, Swede, wood pore and leather), etc. The surface finish of the foil finished boards depends on the original finish of the foil used.

**21.2.1.6 Dimensions and Tolerances:** Dimensions and tolerances shall conform to IS 12049.

**21.2.1.7 Testing:** One sample for every 100 sqm. or part thereof shall be taken and testing done as per IS 12823. For quantity less than 100 sqm, the test certificate from manufacturer shall be relied upon. The Engineer-in-charge may ask for testing even if the quantity is less than 100 sqm.

## 21.2.2 Aluminium Sheet

**21.2.2.1 Aluminium Sheets** for use as panels shall be 1.25 mm thick aluminium alloy sheet conforming to IS 737. Aluminium alloy sheet for use in general paneling work shall be of types and thickness as specified and conforming to the requirement of IS 737. Aluminium sheets shall be of approved make and manufacturer. Aluminium panel may be prefabricated units manufactured on modular or non-modular dimension.

**21.2.2.2 Fixing:** The required size of panel, keeping sufficient margin to be inserted inside the section, shall be cut to correct size and fixed firmly in the frame with CP brass or aluminium or stainless steel screws of star headed, counter sunk and matching size groove. Joints sealed with epoxy resin or silicon sealant to make the unit water proof.

## 21.2.3 Float Glass

**21.2.3.1** The glass shall be clear float glass and should be approved by the Engineer in Charge. It shall be clear, float transparent and free from cracks subject to allowable defects. The float glass shall conform to the IS 14900.

**21.2.3.2 Thickness :** The thickness of float glass shall depend on the size of panel. The tolerance in thickness shall be as under:

**TABLE 21.2**

| Nominal Thickness (in mm ) | Tolerance (in mm ) |
|----------------------------|--------------------|
| 4.0                        | ± 0.3              |
| 5.0                        | ± 0.3              |
| 6.0                        | ± 0.3              |
| 8.0                        | ± 0.6              |

**21.2.3.3 Allowable Defects:** The allowable defects shall be as per Table 21.3 below:

**TABLE 21.3**

| Sl. No. | Defects                                | Central  | Outer | Remarks                       |
|---------|--|--|-------|-------------------------------|
| 1.      | Gaseous inclusion. Max size, mm        | 3.0  | 6.0   | Separated by at least 30.0 cm |
| 2.      | Opaque gaseous inclusion. Max size. mm | 3.0  | 6.0   | Separated by at least 60.0 cm |
| 3.      | Knots, dirt and stones, Max size. mm   | 1.0  | 1.0   | Separated by at least 30.0 cm |
| 4.      | Scratches, Rubs and Crush              | Faint  | Light | Separated by at least 30.0 cm |
| 5.      | Bow, percent. Max                      | 0.5  | 0.5   | See 21.2.4.3                  |
| 6.      | Reams, Strings and lines               | Light  | Light | See 21.2.4.4                  |
| 7.      | Waviness                               | Nil  | Nil   | See 21.2.4.5                  |
| 8.      | Sulphur stains                         | Nil  | Nil   |                               |
| 9.      | Corner breakage and chip               | Not more than nominal thickness of float glass |       |                               |

**21.2.3.4 Allowable Cluster of Defects:** The allowable cluster of defects mentioned under Sl. No. 1, 2 & 3 of Table 21.3 shall be as per IS 14900.

#### 21.2.4 Tests

**21.2.4.1 Thickness:** The thickness of float glass shall be measured with micrometers or a caliper which is graduated to 0.01 mm or with a measuring instrument having an equivalent capacity.

**21.2.4.2 Scratches, Rubs and Crush :** Place the sample of float glass in a vertical position approximately 50 cm from the viewer's position and look through it using either day light without direct sunlight or a background light suitable for observing each type of defect.

| Intensity of Scratches, Rubs, Crush | Intensity Distance Limit                            |
|-------------------------------------|---|
| Faint                               | Shall not be detectable beyond 50 cm                |
| Light                               | Detectable between 50-100 cm and not beyond 100 cm. |

**21.2.4.3 Bow :** Depending on the side on which bow is present, stand the sample vertically on a wooden plank. Stretch a thread edge to edge. Measure the longest perpendicular. Distance from the thread to the surface of float glass facing the thread and express it as percentage of the length of float glass from edge along the thread.

**21.2.4.4 Reams, Strings and Lines :** Focus a light projector with a 500 W lamp and an objective lens with an approximate 5 cm aperture and about 30 cm focal length on a flat white projection screen placed about 760 cm from the light source in a dark room. Place the float glass in a vertical position parallel to the screen between the light and the screen. Move the glass slowly towards the screen with a vertical oscillating motion. The shadowgraph read out is the distance at which the distortion just blends with the general shadow of the glass on the screen.

**TABLE 21.4**

| Intensity of Reams, Strings and Lines | Intensity Distance Limit |
|---------------------------------------|--------------------------|
| Light                                 | 7.5 cm                   |
| Medium                                | 5.0 cm                   |
| Heavy                                 | 2.5 cm                   |

**21.2.4.5 Perspective Distortion:** When tested as per test procedure described below it shall not give distorted vision of straight stripe pattern.

### Test Procedure for Perspective Distortion

Perspective distortion shall be examined by looking through the specimen glass which may be placed at about 4.5 m distance in such a direction that the incident angle to it is 50 degree (4 mm or above) and by observing a screen set up perpendicularly to the line of vision about 4.5 m further ahead of the specimen over the total width of about middle part of the specimen from the horizontal direction. The specimen glass shall be kept with the drawn direction at manufacture vertical and, on the surface of the screen, the strip pattern of white and black parallel straight lines of 25 mm width and inclined 45 degrees from the vertical shall be provided and its surface shall be luster less.

### 21.3 EPDM- GASKETS

The EPDM Gaskets shall be of size and profile as shown in drawings and as called for, to render the glazing, doors, windows, ventilators etc. air and water tight. Samples of gaskets shall be submitted for approval and the EPDM gasket approved by Engineer- in- Charge shall only be used. The contractor shall submit documentary proof of using the above material in the work to the entire satisfaction of Engineer-in-Charge.

The EPDM gasket shall meet the requirements as given in Table 21.5 below:

**TABLE 21.5**

| Sl. No. | Description                           | Standard Follow | Specification     |
|---------|---------------------------------------|-----------------|-------------------|
| 1       | Tensile strength Kg.f/cm <sup>2</sup> | ASTM-D 412      | 70 Min.           |
| 2       | Elongation at break %                 | ASTM-D 412      | 250 Min.          |
| 3       | Modulus 100% Kgf/cm <sup>2</sup>      | ASTM-D 412      | 22 Min.           |
| 4       | Compression set % at 0° CC 22 Hrs.    | ASTM-D 395      | 50 Max.           |
| 5       | Ozone resistance                      | ASTM-D 1149     | No visible cracks |

### 21.4 SEALANT

**21.4.1** The sealants of approved grade and colour shall only be used. The silicone for perimeter joints (between Aluminium section and RCC/Stone masonry) shall be of make approved by the Engineer in Charge.

#### 21.4.2 Method of Application

**Surface Preparation :** Clean all joints and glazing pockets by removing all foreign matter and contaminants such as grease, oil, dust, water, frost, surface dirt, old sealants or glazing compounds and protective coatings.

#### 21.4.3 Masking

Areas adjacent to joints shall be masked to ensure neat sealant lines. Masking tape shall not be allowed to touch clean surfaces to which the silicone sealant is to adhere. Tooling shall be completed in one continuous stroke immediately after sealant application and before a skin forms and masking shall be removed immediately after tooling.

#### 21.4.4 Application

Install backer rod of appropriate size and apply silicone sealant in a continuous operation using a positive pressure adequate to properly fill and seal the joint. The silicone sealant shall be tooled with light pressure to spread the sealant against backing material and the joint surfaces before a skin forms. A tool with convex profile shall be used to keep the sealant within the joint. Soap or water shall not be used as a tooling aid. Remove masking tape as soon as silicone joint is tooled.

**Tolerance:** A tolerance of + 3 mm shall be allowed in the width of silicone joints. The depth of the joints at throat shall not be less than 6 mm.

## 21.5 REFLECTIVE GLASS

### 21.5.1 Definitions

- (i) **Shading Coefficient:** The shading coefficient is the ratio of total solar transmittance to the transmittance through 3.2 mm (1/8") clear glass. Windows with low shading coefficient values improve comfort for building, lower the total cooling load of the building and help smooth out of the difference in cooling loads between perimeter & core zones.
- (ii) **Luminous Efficacy Constant (Ke)** indicates a windows relative performance in rejecting solar heat-while transmitting day light. It is the ratio of the visible transmittance to the shading coefficient; clear glass which lets in roughly equal amounts of visible light and solar near-infrared energy has a Ke close to 1.0. The solar radiation contains about 50% invisible near-infrared & ultra violet light. Therefore, a perfectly selective glazing, which would all allow visible light pass through while blocking all of the invisible near-infrared & ultraviolet light, would have Ke of about 2.0.
- (iii) **Resistance to Heat Conduction (R-value):** It is a measure of resistance to heat flow that occurs because of temperature difference between the two sides of the windows. The inverse of R-value is termed as U-value.

### 21.5.2 Reflective Glass

This is an ordinary float glass with a metallic coat to reduce solar heat. Clear glass transmits most of the sunlight that shines upon it, and most of the solar heat as well; the metallic coated glass i.e. reflective glass has better shading coefficients because they reflect rather than absorb infrared energy. However, most of reflective glazing blocks day light more than solar heat.

**21.5.2.1 Types of Coatings:** There are two types of reflective glass, Pyrolytic (Hard) coated and vacuum (soft) coated.

- (i) **Pyrolytic :** It is a coating applied during glass manufacture. The coating is fused into the glass at 1200°C.
- (ii) **Vacuum Coated Glass:** It involves the deposition of metal particles on the glass surface by a chain reaction in a vacuum vessel. It is often called a soft coat; because the coating is more susceptible to damage than hard coat glass. Where toughening of product is required, the product must be toughened first & then vacuum coated. Vacuum coated products have better shading coefficient values than pyrolytic products.

**21.5.2.2 Performance of Reflective Glass:** The performance of reflective glass 6 mm of nominal thickness is given below:

| Sl. No. | Parameter   | Threshold Ratio In %age |
|---------|---|-------------------------|
| 1       | Visible Light<br>- Transmittance (%)<br>- Reflectance (%)       | 15-46<br>12-24          |
| 2       | Total Solar Energy:<br>- Transmittance (%)<br>- Reflectance (%) | 16-24<br>8-12           |
| 3       | Ultra Violet Rays:<br>- Transmittance (%)                       | 2-10                    |
| 4       | U-Value<br>- Summer<br>- Winter                                 | 0.58<br>0.45            |
| 5       | Shading Coefficient   | 0.25-0.35               |

**21.5.2.3 Testing:** The reflective glass shall be tested for the followings:

- (i) **Physical/Field Test:** In a true reflective glass, when a pointed pencil is placed, then tip of pencil (physical) & image should coincide.
- (ii) **Lab. Test:** In the lab, the reflective glass shall be tested for the parameter specified in 21.5.2.2 above.

**21.5.2.4** Fixing of glass shall be done as specified.



## **21.6 DOOR, WINDOW, VENTILATOR AND PARTITION FRAMES**

### **21.6.1 Frame Work**

First of all the shop drawings for each type of doors/windows/ventilators etc. shall be prepared by using suitable sections based on architectural drawings, adequate to meet the requirement/specifications and by taking into consideration varying profiles of aluminium sections being extruded by approved manufacturers. The shop drawings shall show full size sections of glazed doors, windows, ventilators etc. The shop drawings shall also show the details of fittings and joints. Before start of the work, all the shop drawings shall be got approved from the Engineer-in-Charge.

Actual measurement of openings left at site for different type of door/window etc. shall be taken. The fabrication of the individual door/windows/ventilators etc. shall be done as per the actual sizes of the opening left at site. The frames shall be truly rectangular and flat with regular shape corners fabricated to true right angles. The frames shall be fabricated out of section which have been cut to length, mitered and jointed mechanically using appropriate machines. Mitered joints shall be corner crimped or fixed with self tapping stainless steel screws using extruded aluminium cleats of required length and profile. All aluminium work shall provide for replacing damaged/broken glass panes without having to remove or damage any member of exterior finishing material.

### **21.6.2 Fixing of Frames**

The holes in concrete/masonry/wood/any other members for fixing anchor bolts/fasteners/screws shall be drilled with an appropriate electric drill. Windows/doors/ventilators etc. shall be placed in correct final position in the opening and fixed to Sal wood backing using stainless steel screws of star headed, counter sunk and matching size groove. of required size at spacing not more than 250 mm c/c or dash fastener. All joints shall be sealed with approved silicone sealants.

In the case of composite windows and doors, the different units are to be assembled first. The assembled composite units shall be checked for line, level and plumb before final fixing is done. Engineer -in-Charge in his sole discretion may allow the units to be assembled in their final location if the situation so warrants. Snap beadings and EPDM gasket shall be fixed as per the detail shown in the shop drawings.

Where aluminium comes into contact with stone masonry, brick work, concrete, plaster or dissimilar metal, it shall be coated with an approved insulation lacquer, paint or plastic tape to ensure that electrochemical corrosion is avoided. Insulation material shall be trimmed off to a clean flush line on completion.

The contractor shall be responsible for the doors, windows etc. being set straight, plumb, level and for their satisfactory operation after fixing is complete.

### **21.6.3 Measurements**

All the aluminium sections including snap beadings fixed in place shall be measured in running meter along the outer periphery of composite section correct to a millimeter. The weight calculated on the basis of actual average (average of five samples) weight of composite section in kilogram correct to the second place of decimal shall be taken for payment (weight shall be taken after anodizing). The weight of cleat shall be added for payment. Neither any deduction nor anything extra shall be paid for skew cuts.

### **21.6.4 Rate**

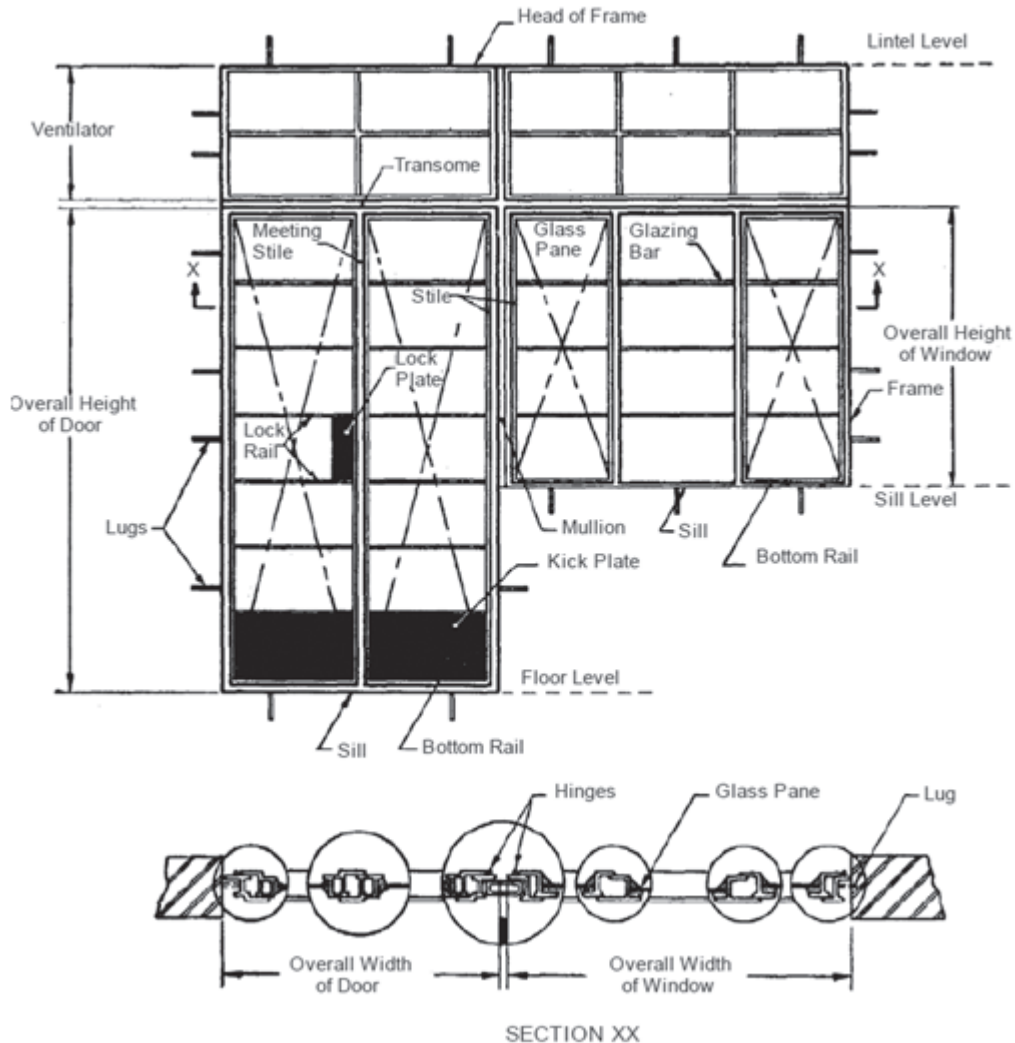
The rate shall include the cost of all the materials, labour involved in all the operations as described in nomenclature of item and particular specification.

## 21.7 DOOR, WINDOWS AND VENTILATOR SHUTTERS

Material, fabrication and dimensions of aluminium doors, windows and ventilators manufactured from extruded aluminium alloy sections of standard sizes and designs complete with fittings, ready for being fixed into the building shall be as per IS 1948.

### 21.7.1 Terminology

The components of doors, windows and ventilators shall be defined as in Figure 21.1 below.

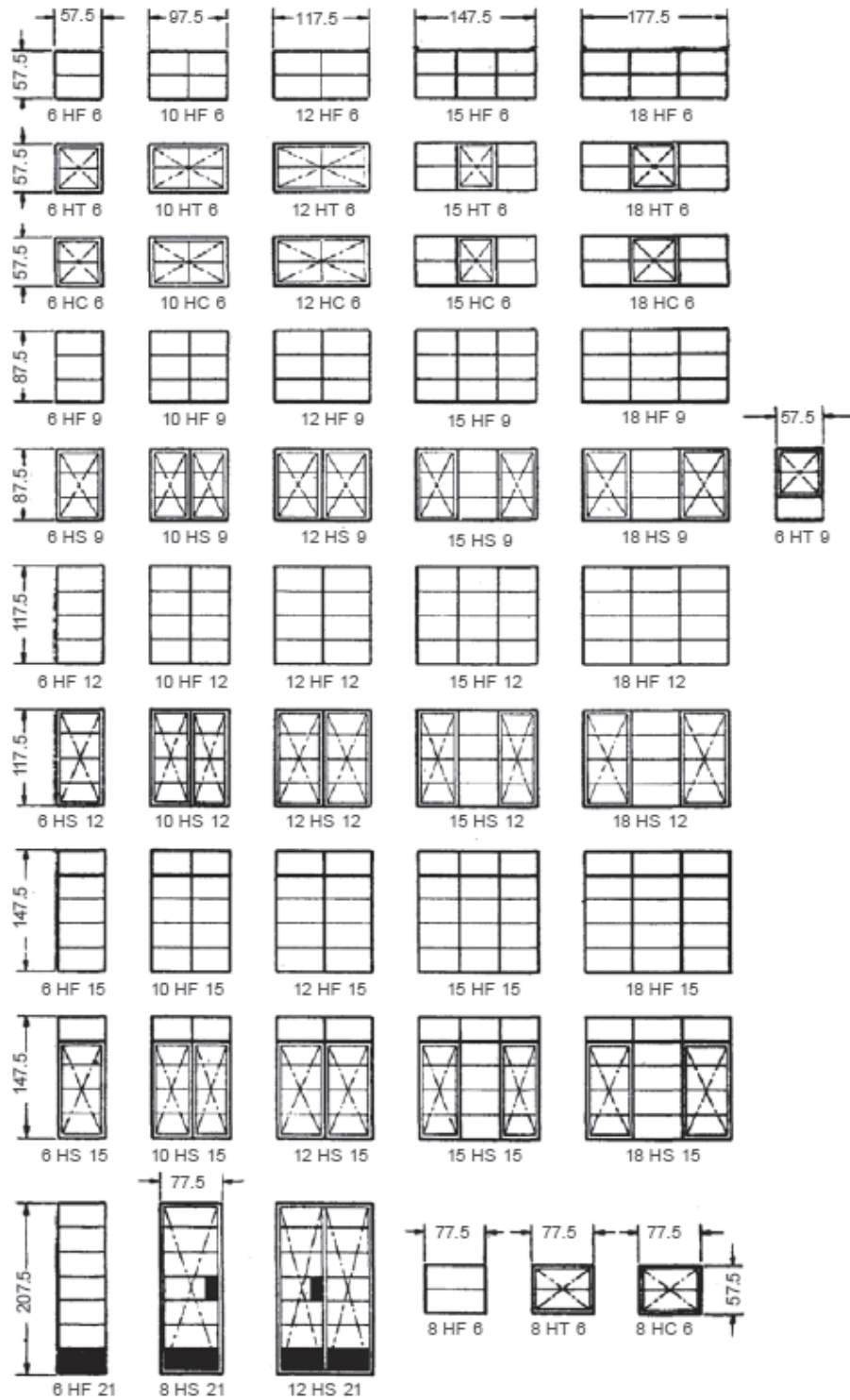


**Fig. 21.1 : Terminology for Aluminium Doors, Windows and Ventilators**

### 21.7.2 Standard Sizes, Tolerances and Designations

The types and the overall sizes of aluminium doors, windows and ventilators shall be as given in Figure 21.2. Their sizes are derived after allowing 1.25 mm clearances on all the four sides for the purpose of fitting the doors, windows and ventilators into modular openings.





**Note : 1.** Windows without horizontal glazing bars shall be designated by 'N' in place of 'H' in the range shown.

**Note : 2.** Doors and side lights shall only be coupled with 12 module (117.5 cm) high windows.  
All dimensions in centimetres

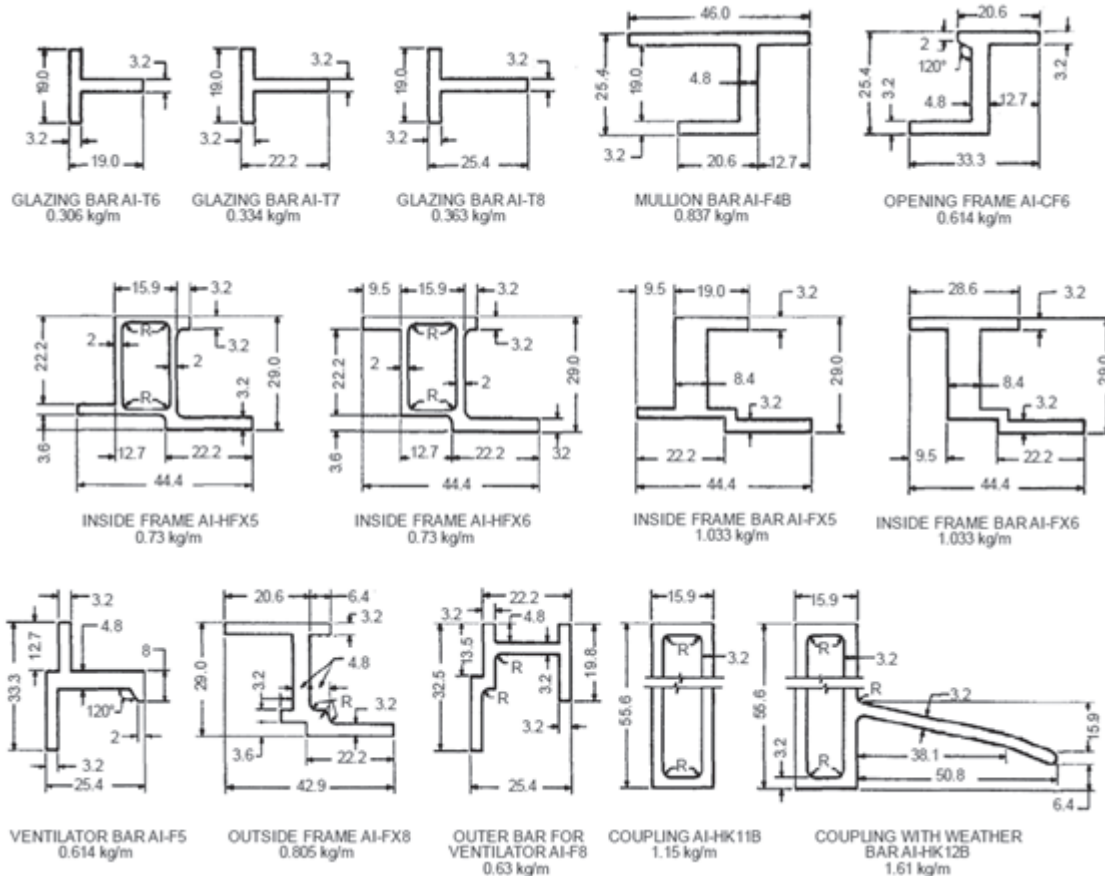
**Fig. 21.2 : Types and Size of Aluminium Doors, Windows and Ventilators**

### 21.7.3 Tolerances

The sizes for doors, windows and ventilators frames shall not vary by more than  $\pm 1.5$  mm.

### 21.7.4 Material

Aluminium alloy extruded sections used in the manufacture of extruded window sections shall conform to IS 733. Hollow aluminium alloy sections used shall conform to IS 1285. Dimension and weight per metre run of the extruded sections shall be as given in Figure 21.3.



Note 1 : All radii R = 1.6 mm

Note 2 : The weights of sections per metre length as indicated are nominal.

All dimensions in millimeters

**Fig. 21.3 : Extruded Aluminium Sections for Doors, Windows and Ventilators**

### 21.7.5 Glass Panes

Glass panes shall weigh at least  $7.5 \text{ kg/m}^2$  and shall be free from flaws, specks or bubbles. All panes shall have properly squared corners and straight edges. The sizes of glass panes for use in doors, windows and ventilators shall be as given in Table 21.6.

### 21.7.6 Screws

Screws threads of machine screws used in the fabrication of aluminium doors, windows and ventilators shall conform to IS 1362.

**TABLE 21.6**  
**Glass Sizes (Clearance Allowed)**  
*(Clause 21.7.5)*

| <i>Designation</i>                  | <i>Quantity</i>      | <i>Glass size Width X Height cm</i>                        |
|-------------------------------------|----------------------|--|
| <b>No Glazing Bar Fixed Type</b>    |                      |  |
| 6NF6                                | 1                    | 53.0 x 53.0  |
| 10NF6                               | 2                    | 45.0 x 53.0  |
| 12NF6                               | 2                    | 55.0 x 53.0  |
| 15NF6                               | {2<br>{1             | 45.0 x 53.0<br>47.5 x 53.0                                 |
| 18NF6                               | {2<br>{1             | 55.0 x 53.0<br>57.5 x 53.0                                 |
| 6NF9                                | 1                    | 53.0 x 83.0  |
| 10NF9                               | 2                    | 45.0 x 83.0  |
| 12NF9                               | 2                    | 55.0 x 83.0  |
| 15NF9                               | {2<br>{1             | 45.0 x 83.0<br>47.5 x 83.0                                 |
| 18NF9                               | {2<br>{1             | 55.0 x 83.0<br>57.5 x 83.0                                 |
| 6NF12                               | 1                    | 53.0 x 113.0   |
| 10NF12                              | 2                    | 45.0 x 113.0   |
| 12NF12                              | 2                    | 55.0 x 113.0   |
| 15NF12                              | {2<br>{1             | 45.0 x 113.0<br>47.5 x 113.0                               |
| 18NF12                              | {2<br>{1             | 55.0 x 113.0<br>57.5 x 113.0                               |
| 6NF15                               | {1<br>{1             | 53.0 x 27.0<br>53.0 x 113.0                                |
| 10NF15                              | {2<br>{2             | {45.0 x 27.0<br>{45.0 x 113.0                              |
| 12NF15                              | {2<br>{2             | 55.0 x 27.0<br>55.0 x 113.0                                |
| 15NF15                              | {2<br>{1<br>{2<br>{1 | 45.0 x 27.0<br>47.5 x 27.0<br>45.0 x 113.0<br>47.5 x 113.0 |
| 18NF15                              | {2<br>{1<br>{2<br>{1 | 55.0 x 27.0<br>57.5 x 27.0<br>55.0 x 113.0<br>57.5 x 113.0 |
| 8NF6                                | 1                    | 73.0 x 53.0  |
| 6NF21                               | {1<br>{1<br>{1       | 53.0 x 84.5<br>53.0 x 27.5<br>53.0 x 56.0                  |
| <b>No Glazing Bar Top-Hung Type</b> |                      |  |
| 6NT6                                | 1                    | 50.0 x 50.0  |
| 10NT6                               | 2                    | 44.5 x 50.0  |
| 12NT6                               | 2                    | 54.5 x 50.0  |
| 15NT6                               | {2<br>{1             | 45.0 x 53.0<br>45.5 x 50.0                                 |
| 18NT6                               | {2<br>{1             | 55.0 x 53.0<br>54.5 x 50.0                                 |
| 8NT6                                | 1                    | 70.0 x 50.0  |
| 6NT9                                | {1<br>{1             | 50.0 x 51.5<br>53.0 x 27.5                                 |

| <i>Designation</i>                     | <i>Quantity</i>      | <i>Glass size Width X Height cm</i>                        |
|--|----------------------|--|
| <b>No Glazing Bar Centre-Hung Type</b> |                      |  |
| 6NC6                                   | 1                    | 46.0 x 46.0  |
| 10NC6                                  | 2                    | 42.5 x 46.0  |
| 12NC6                                  | 2                    | 52.5 x 46.0  |
| 15NC6                                  | {2<br>{1             | 45.0 x 53.0<br>43.5 x 46.0                                 |
| 18NC6                                  | {2<br>{1             | 55.0 x 53.0<br>53.5 x 46.0                                 |
| 8NC6                                   | 1                    | 66.0 x 46.0  |
| <b>No Glazing Bar Side-Hung Type</b>   |                      |  |
| 6NS9                                   | 1                    | 50.0 x 80.0  |
| 10NS9                                  | 2                    | 43.5 x 80.0  |
| 12NS9                                  | 2                    | 52.5 x 80.0  |
| 15NS9                                  | {2<br>{1             | 43.5 x 80.0<br>47.5 x 83.0                                 |
| 18NS9                                  | {2<br>{1             | 52.5 x 80.0<br>57.5 x 83.0                                 |
| 6NS12                                  | 1                    | 50.0 x 110.0   |
| 10NS12                                 | 2                    | 43.5 x 110.0   |
| 12NS12                                 | 2                    | 52.5 x 110.0   |
| 15NS12                                 | {2<br>{1             | 43.5 x 110.0<br>47.5 x 113.0                               |
| 18NS12                                 | {2<br>{1             | 53.0 x 27.0<br>50.0 x 110.0                                |
| 6NS15                                  | {1<br>{1             | 53.0 x 27.0<br>50.0 x 110.0                                |
| 10NS15                                 | {2<br>{2             | 45.0 x 27.0<br>43.5 x 110.0                                |
| 12NS15                                 | {2<br>{2             | 55.0 x 27.0<br>52.5 x 110.0                                |
| 15NS15                                 | {2<br>{1<br>{2<br>{1 | 45.0 x 27.0<br>47.5 x 27.0<br>43.5 x 110.0<br>47.5 x 113.0 |
| 18NS15                                 | {2<br>{1<br>{2<br>{1 | 55.0 x 27.0<br>57.5 x 27.0<br>52.5 x 110.0<br>57.5 x 113.0 |
| 8NS21                                  | {1<br>{1<br>{1       | 66.0 x 81.0<br>56.0 x 27.5<br>66.0 x 56.0                  |
| 12NS21                                 | {2<br>{2<br>{1<br>{1 | 50.5 x 81.0<br>50.5 x 56.0<br>50.5 x 27.5<br>40.5 x 27.5   |

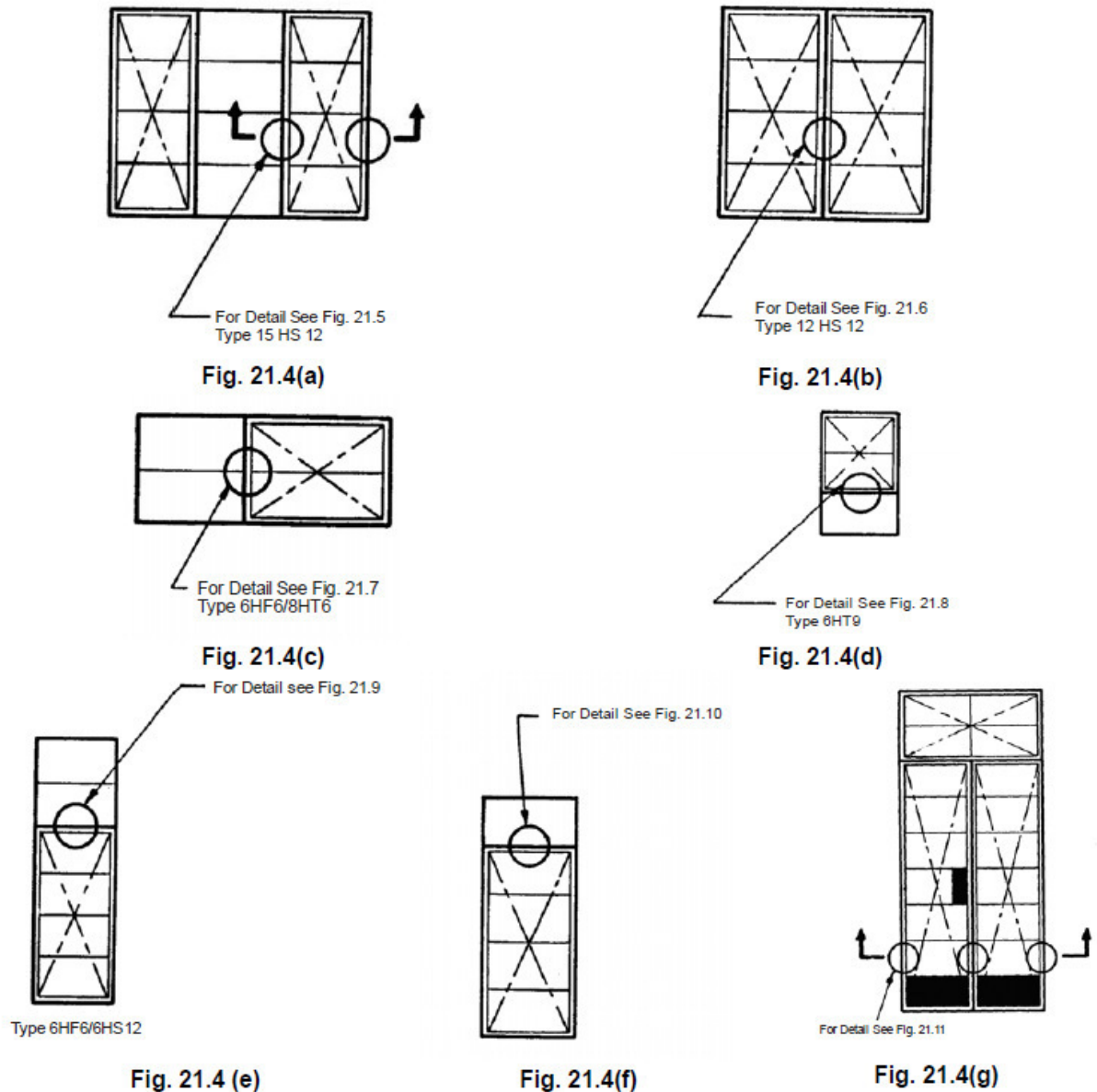
| Designation                                 | Quantity          | Glass size Width X Height cm                             |
|---|-------------------|--|
| <b>Horizontal Glazing Bar Fixed Type</b>    |                   |  |
| 6HF6  | 2                 | 53.0 x 26.0  |
| 10HF6                                       | 4                 | 45.0 x 26.0  |
| 12HF6                                       | 4                 | 55.0 x 26.0  |
| 15HF6                                       | {4<br>2           | 45.0 x 26.0<br>47.5 x 26.0                               |
| 18HF6                                       | {4<br>2           | 55.0 x 26.0<br>57.5 x 26.0                               |
| 6HF9  | {2<br>1           | 53.0 x 27.5<br>53.0 x 26.0                               |
| 10HF9                                       | {4<br>2           | 45.0 x 27.5<br>45.0 x 26.0                               |
| 12HF9                                       | {4<br>2           | 55.0 x 27.5<br>55.0 x 26.0                               |
| 15HF9                                       | {4<br>2<br>2<br>1 | 45.0 x 27.5<br>45.0 x 26.0<br>47.5 x 27.5<br>47.5 x 26.0 |
| 18HF9                                       | {4<br>2<br>2<br>1 | 55.0 x 27.5<br>55.0 x 26.0<br>57.5 x 27.5<br>57.5 x 26.0 |
| 6HF12                                       | 4                 | 53.0 x 27.5  |
| 10HF12                                      | 8                 | 45.0 x 27.5  |
| 12HF12                                      | 8                 | 55.0 x 27.5  |
| 15HF12                                      | {8<br>4           | 45.0 x 27.5<br>47.5 x 27.5                               |
| 18HF12                                      | {8<br>4           | 55.0 x 27.5<br>57.5 x 27.5                               |
| 6HF15                                       | {1<br>4           | 53.0 x 27.0<br>53.0 x 27.5                               |
| 10HF15                                      | {2<br>8           | 45.0 x 27.0<br>45.0 x 27.5                               |
| 12HF15                                      | {2<br>8           | 55.0 x 27.0<br>55.0 x 27.5                               |
| 15HF15                                      | {2<br>1<br>8<br>4 | 45.0 x 27.0<br>47.5 x 27.0<br>45.0 x 27.5<br>47.5 x 27.5 |
| 18HF15                                      | {2<br>1<br>8<br>4 | 55.0 x 27.0<br>57.5 x 27.0<br>55.0 x 27.5<br>57.5 x 27.5 |
| 8HF6  | 2                 | 73.0 x 26.0  |
| 6HF21                                       | 6                 | 53.0 x 27.5  |
| <b>Horizontal Glazing Bar Top-Hung Type</b> |                   |  |
| 6HT6  | 2                 | 50.0 x 24.5  |
| 10HT6                                       | 4                 | 44.5 x 24.5  |
| 12HT6                                       | 4                 | 54.5 x 24.5  |
| 15HT6                                       | {4<br>2           | 45.0 x 26.0<br>44.5 x 24.5                               |
| 18HT6                                       | {4<br>2           | 55.0 x 26.0<br>54.5 x 24.5                               |
| 6HT9  | {1<br>1<br>1      | 50.0 x 26.0<br>50.0 x 24.5<br>53.0 x 27.5                |
| 8HT6  | 2                 | 70.0 x 24.5  |

| Designation                                    | Quantity          | Glass size Width X Height cm                             |
|--|-------------------|--|
| <b>Horizontal Glazing Bar Centre-Hung Type</b> |                   |  |
| 6HC6   | 2                 | 46.0 x 22.5  |
| 10HC6  | 4                 | 42.5 x 22.5  |
| 12HC6  | 4                 | 52.5 x 22.5  |
| 15HC6  | {4<br>2           | 45.0 x 26.0<br>43.5 x 22.5                               |
| 18HC6  | {4<br>2           | 55.0 x 26.0<br>53.5 x 22.5                               |
| 8HC6   | 2                 | 66.0 x 22.5  |
| <b>Horizontal Glazing Bar Side-Hung Type</b>   |                   |  |
| 6HS9   | 3                 | 50.0 x 26.0  |
| 10HS9  | 6                 | 43.5 x 26.0  |
| 12HS9  | 6                 | 52.5 x 26.0  |
| 15HS9  | {6<br>2<br>1      | 43.5 x 26.0<br>47.5 x 27.5<br>47.5 x 26.0                |
| 18HS9  | {6<br>2<br>1      | 52.5 x 26.0<br>57.5 x 27.5<br>57.5 x 26.0                |
| 6HS12  | {2<br>2           | 50.0 x 26.0<br>50.0 x 27.5                               |
| 10HS12   | {4<br>4           | 43.5 x 26.0<br>43.5 x 27.5                               |
| 12HS12   | {4<br>4           | 52.5 x 26.0<br>52.5 x 27.5                               |
| 15HS12   | {4<br>4<br>4      | 43.5 x 26.0<br>43.5 x 27.5<br>47.5 x 27.5                |
| 18HS12   | {4<br>4<br>4      | 52.5 x 26.0<br>52.5 x 27.5<br>57.5 x 27.5                |
| 6HS15  | {1<br>2<br>2      | 53.0 x 27.0<br>50.0 x 26.0<br>50.0 x 27.5                |
| 10HS15   | {2<br>4<br>4      | 45.0 x 27.0<br>43.5 x 26.0<br>43.5 x 27.5                |
| 12HS15   | {2<br>4<br>4      | 55.0 x 27.0<br>52.5 x 26.0<br>52.5 x 27.5                |
| 15HS15   | {2<br>1<br>4<br>4 | 45.0 x 27.0<br>47.5 x 27.0<br>43.5 x 26.0<br>43.5 x 27.5 |
| 18HS15   | {2<br>1<br>4<br>4 | 55.0 x 27.0<br>57.5 x 27.0<br>52.5 x 26.0<br>52.5 x 27.5 |
| 8HS21  | {1<br>4<br>1      | 66.0 x 24.0<br>66.0 x 27.5<br>56.0 x 27.5                |
| 12HS21   | {2<br>9<br>1      | 50.5 x 24.0<br>50.5 x 27.5<br>40.5 x 27.5                |

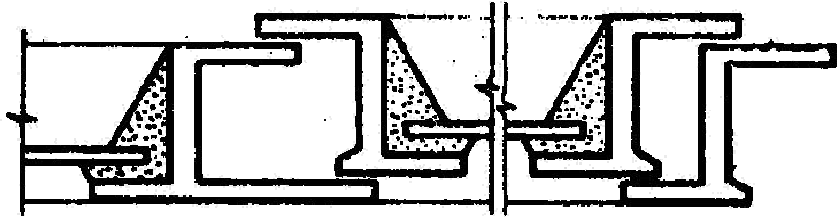
### 21.7.7 Fabrication

**Frames:** Frames shall be square and flat, the corners of the frame being fabricated to a true right angle. Both the fixed and opening frames shall be constructed of sections which have been cut to length, mitered and welded at the corners. Where hollow sections are used with welded joints, argon-arc welding or flash butt welding shall be employed (gas welding or brazing not to be done). Subdividing bars of units shall be tenoned and riveted into the frame.

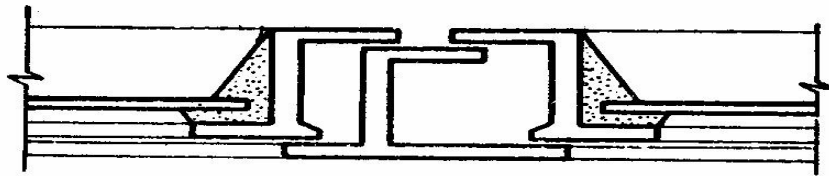
The location of the parts and details of construction of the doors, windows and ventilators are indicated in Fig. 21.4 to 21.11.



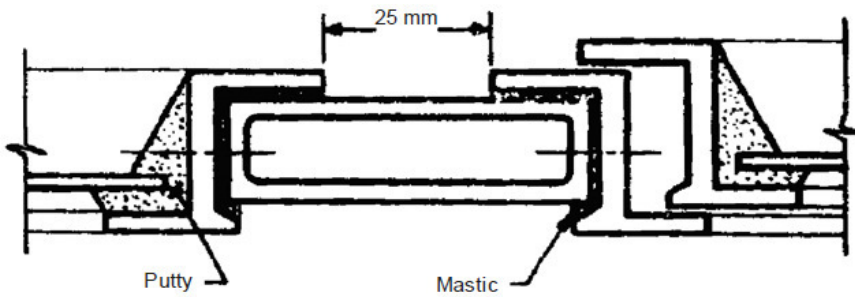
**Fig. 21.4 : Location of Parts of Aluminium Doors, Windows and Ventilators for which Details are Shown**



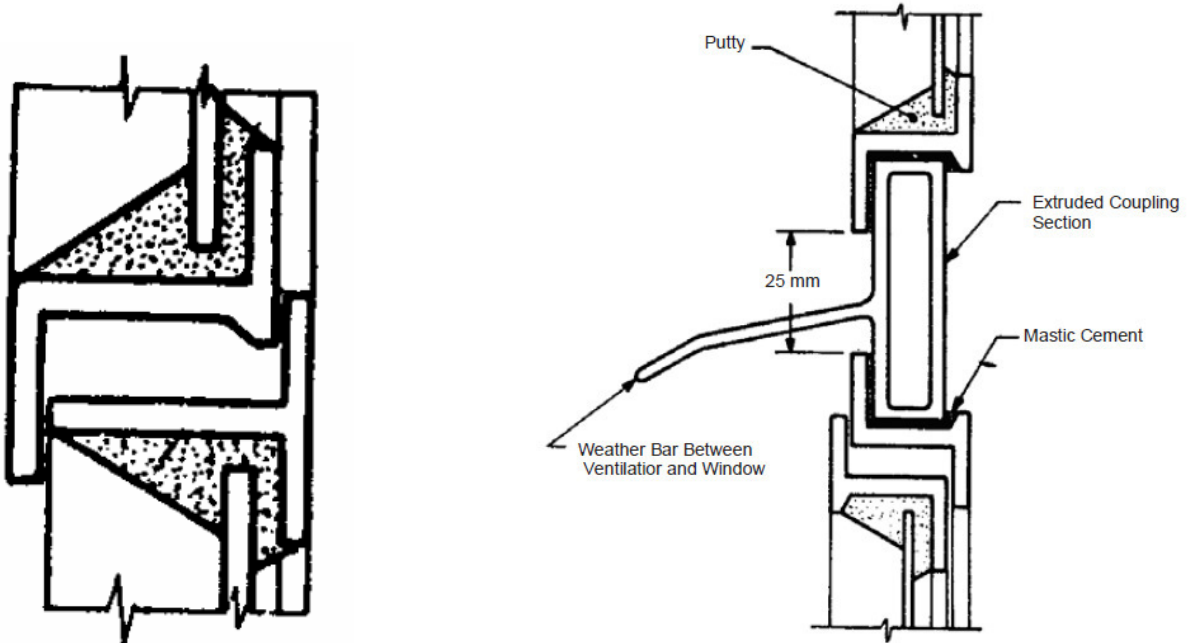
**Fig 21.5 : Mullion with Fixed Glass on one Side and Side Hung on Other Side**



**Fig 21.6 : Mullion with Side Hung Shutter Both Sides**



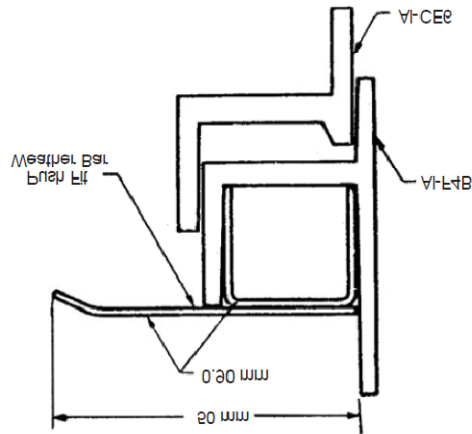
**Fig 21.7 : Coupling Section Extruded for Coupling Windows Side by Side**



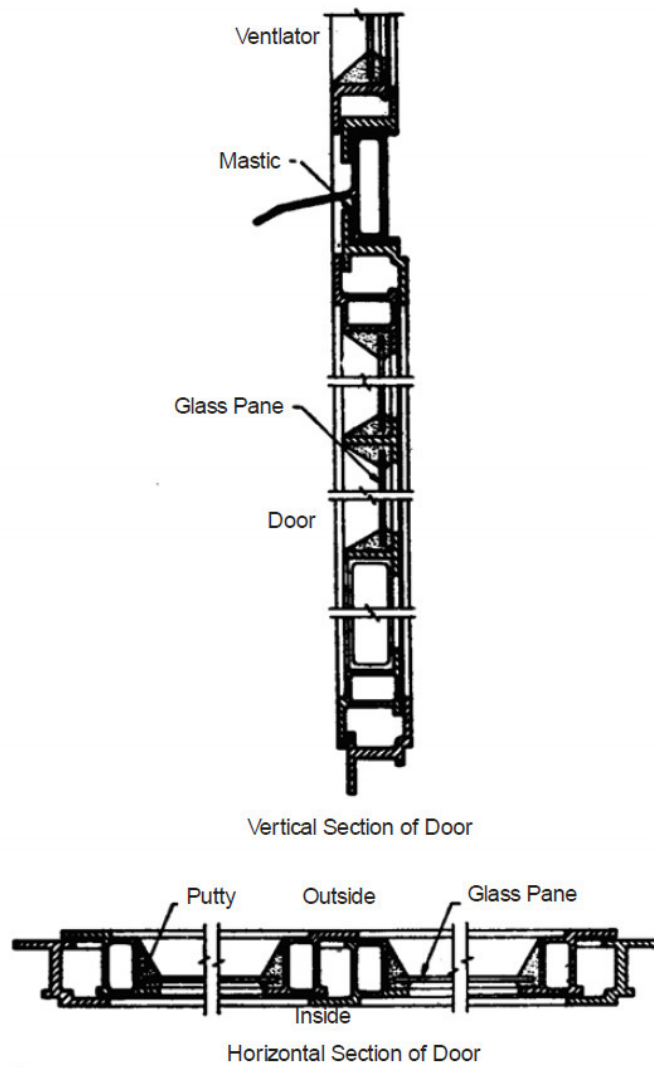
**Fig 21.8 : Detail Through Bottom of Top-Hung Ventilator**

**Fig 21.9 : Coupling Section Extruded having Weather Bar Fitted with Ventilators on top of Windows**





**Fig 21.10 : Weather Bar over Extruded Opening Shutter with Fixed Light Above**



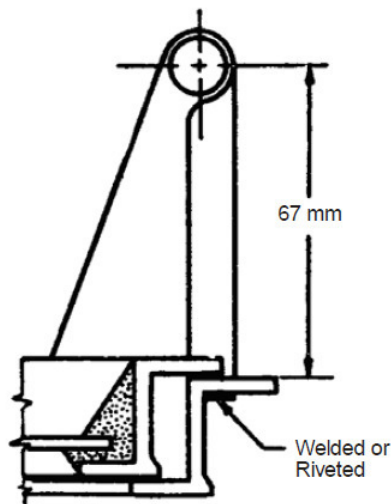
**Fig 21.11 : Detail of Aluminium Double Shutter Door**

### 21.7.8 Side-hung Shutters

For fixing aluminium alloy hinges, slots shall be cut in the fixed frame and the hinges inserted inside and may be riveted to the frame. The hinges shall normally be of the projecting type 67 mm wide (Fig. 21.12). The aluminium alloy for cast hinges shall conform to IS Designation A-5-M of IS 617. Specification for Aluminium and Aluminium Alloy Ingots and Castings for General Engineering Purpose and for extruded section of hinges to IS Designation HE10-WP or HE30-WP of IS 733. The pins for hinges shall be of stainless steel of non-magnetic type or aluminium alloy HR30. Irrespective of hinges being anodized or not, the aluminium alloy pins shall be anodized to a minimum film thickness of 0.025 mm shall be sealed with oil, wax or lanolin. Non- projecting types of hinges may also be used where ever required. (Fig. 21.13).

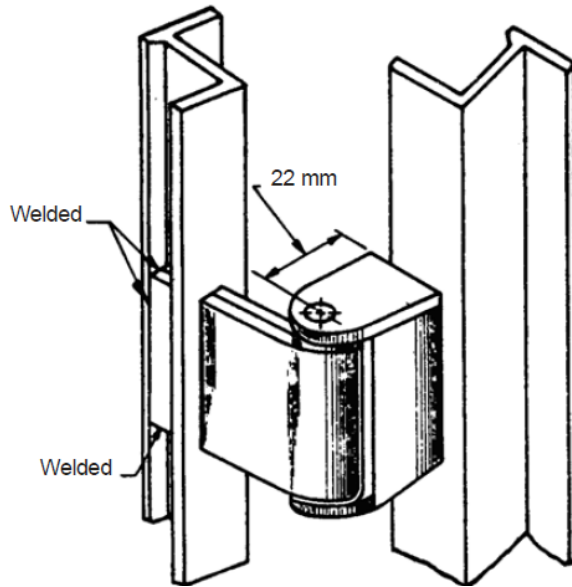
Frictions hinges may be provided for side-hung shutter windows, in which case peg stay may not be required. The working principle of the friction hinges is illustrated in Fig. 21.14.

The handle for side- hung shutters shall be of cast aluminium conforming to IS Designation A-5-M of IS 617 and mounted on a handle plate welded or riveted to the opening frame in such a way that it could be fixed before the shutter is glazed. The handle should have anodized finish with minimum anodic film thickness of 0.015 mm. The handle shall have a two points nose which shall engage with an aluminium striking plate on the fixed frame in a slightly open position as well as in a fast position (Fig. 21.15). The height of the handles in each type of side-hung shutters shall be fixed in approximate position as indicated in Fig. 21.16.

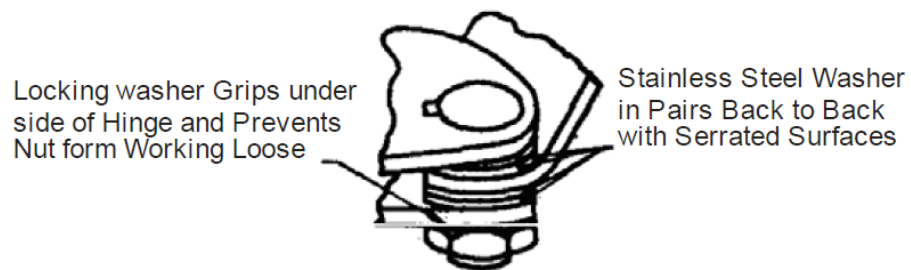


**Fig. 21.12 : Typical Projecting Type Hinge for Side-Hung Shutters**

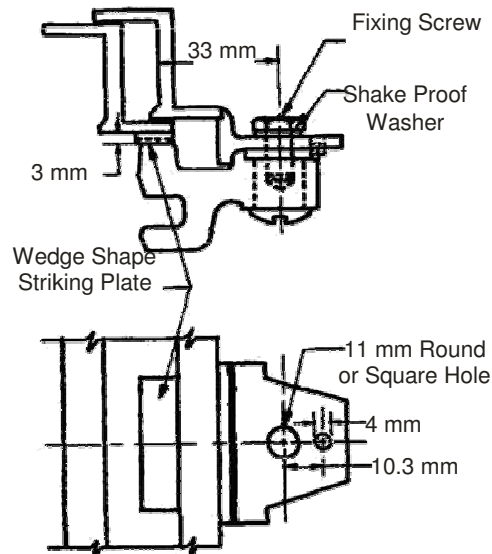




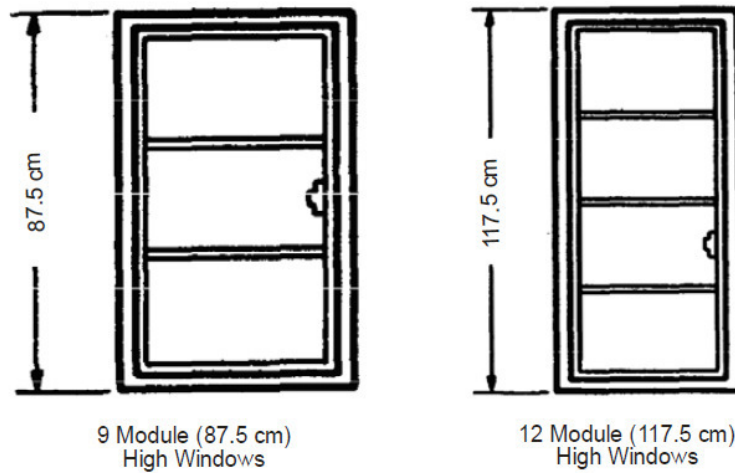
**Fig. 21.13 : Typical Non-Projecting Type Hinge for Side-Hung Shutters**



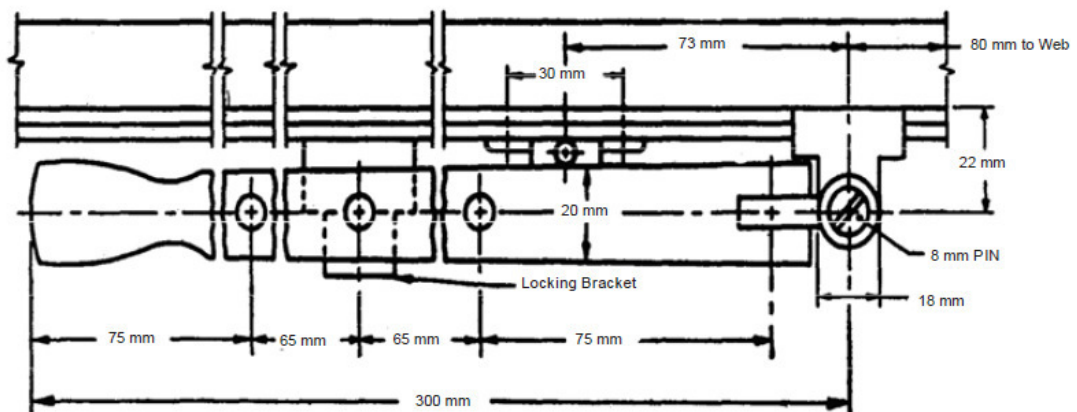
**Fig. 21.14 : Illustration Showing Working Principle of Friction Stay**



**Fig. 21.15 : A Typical Handle for Side-Hung Shutter**



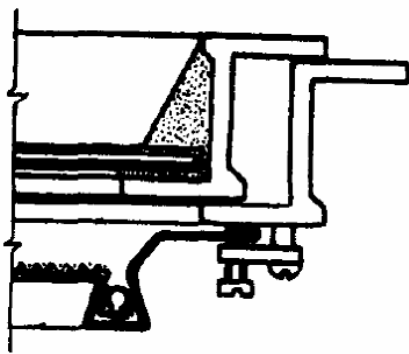
**Fig. 21.16: Position of Handle Plates in Relation to Heights of 'HS' Type Windows**



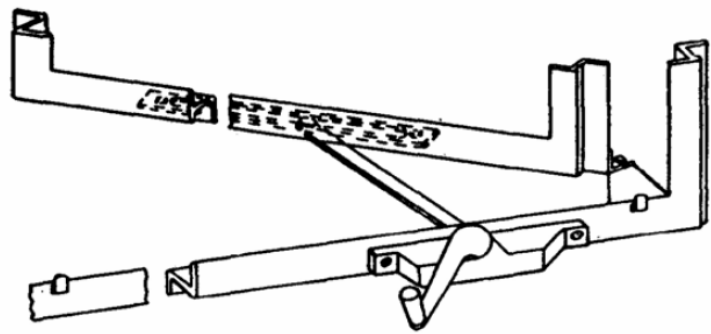
**Fig. 21.17 : A Typical Peg-Stay for Side-Hung Shutters and Top-Hung Ventilators**

The peg stay shall be either of cast aluminium conforming to IS 617 or folded from IS Designation NS4 aluminium alloy sheet conforming to IS:737 specification for wrought aluminium and aluminium alloys, Sheet and strip. It shall be 300 mm long, complete with peg and locking brackets (Fig. 21.17). The stay shall have holes for keeping the shutter open in three different positions. The peg and locking bracket shall be riveted or welded to the fixed frame.

Alternatively, and if specifically required by the purchaser, side- hung shutters may be fitted with an internal removable fly screen of 0.375 mm wire and equivalent to IS Sieve 100 in a 0.900 mm aluminium alloy sheet conforming to IS Designation NS3-1/2H of IS 737 applied to the outer frame of the shutter by case or extruded aluminium alloy turn-buckle at the jambs (Fig. 21.18) and by aluminium or plated bronze shoes at the sill to allow of the screen being readily removed, and with a rotor operator at the sill to permit the operation of the shutter through an angle of 90° (Fig. 21.19). On fly-screened shutters the peg stay is omitted and the normal handle shall be replaced by a locking handle to hold the shutter in the fast position.



**Fig. 21.18 : Detail Through Jamb Showing Turnbuckle**



**Fig. 21.19 : Typical Rotor Operator for Side-Hung Shutters Fitted with Fly Screens**

### 21.7.9 Top-Hung Ventilators

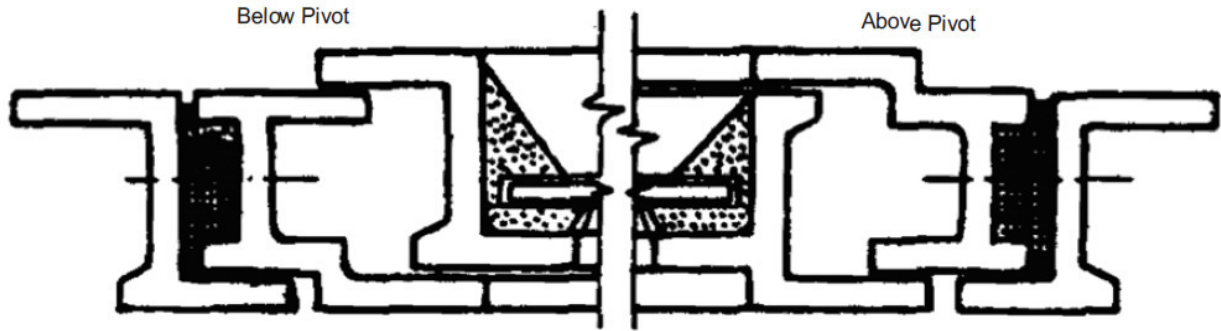
The aluminium hinges for top- hung ventilators shall be either cast or fabricated out of extruded sections and shall be riveted to the fixed rail after cutting a slot in it. The aluminium alloy for cast hinges shall conform to IS Designation A-5-M of IS 617 and the extruded section of hinge to IS Designation HE10-WP or HE30\_WP of IS 733

The pegs stay shall be 300 mm long as in side-hung shutter (Fig. 21.17). The locking bracket shall be fixed to the fixed frame.

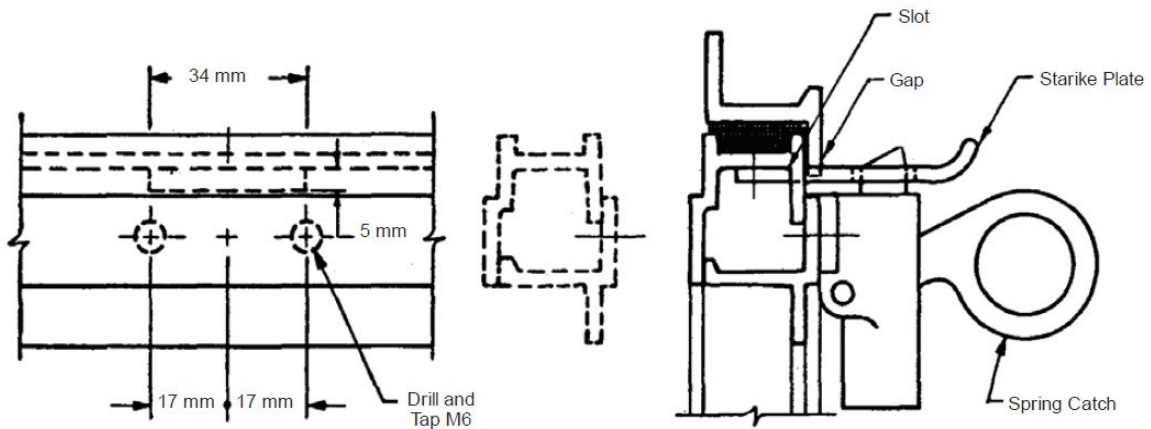
### 21.7.10 Centre-Hung Ventilators (Fig.21.20)

Centre hung ventilators shall be hung on two pairs of cup pivots of aluminium alloy to IS Designation NS-4 of IS 737 and IS Designation A-5- M of IS 617 or on brass or bronze cup pivots which should be either chromium or cadmium plated and riveted to the inner and outer frames of the ventilators to permit the ventilator to swing through an angle of approximately 85°. The opening portion of the ventilator shall be so balanced that it remains open at any desired angle under normal weather condition.

Cast aluminium conforming to IS Designation A-5-M of IS 617 or bronze which shall be either chromium-plated or cadmium-plated spring catch shall be fitted in the centre of the top bar of the ventilators for the operation of the ventilator. This spring catch shall be secured to the frame and shall close into aluminium catch plate riveted or welded to the outside of the outer ventilator frame bar (Fig. 21.21).

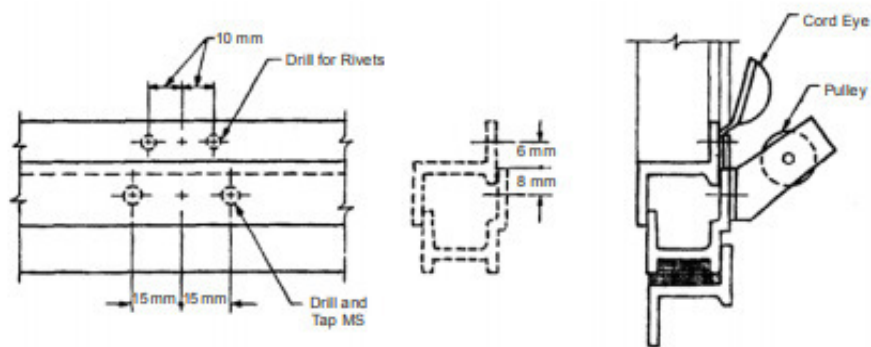


**Fig. 21.20 : Detail of Horizontal Centre-Hung Ventilator**



**Fig. 21.21: Spring Catch for Centre-Hung Ventilator**

Aluminium or cadmium plated brass cord pulley -wheel in an aluminium bracket shall be fitted at the sill of the ventilator with aluminium or galvanized or cadmium plated steel screw or, alternatively, welded together with an aluminium cord eye riveted or welded to the bottom inner frame bar of the ventilator in a position corresponding to that of pulley (Fig. 21.22).



**Fig. 21.22 : Cord Eye and Pulley Arrangement for Centre-Hung Ventilator**

### 21.7.11 Doors

The outer fixed frame shall be of section A1-FX8. The shutter frame shall be of either hollow sections A1-HFX5 and A1-HFX6 (Fig. 21.3 and Fig. 21.11).

The kick panels shall be of 1.25 mm aluminium alloy sheet conforming to IS Designation NS3-1/2H of IS 737 specification for Wrought Aluminium and Aluminium Alloys, Sheet and strip and shall be screwed to the frame and the glazing bar.

**Hinges** –Cast of extruded aluminium alloy hinges for doors shall be of the same type as in the windows but of larger size. The hinges shall normally be of the 50 mm projecting type (Fig. 21.23). Non-projecting type of hinges may also be used (Fig. 21.24).

The handle for doors may be of the design indicated in Fig. 21.25.

A suitable lock for the door operable either from inside or outside shall be provided.

**Note:** From the point of view of security, the lock which is operable from only one side is better and in the case of such locks, a bolt shall be provided to make them inoperable from the other side.

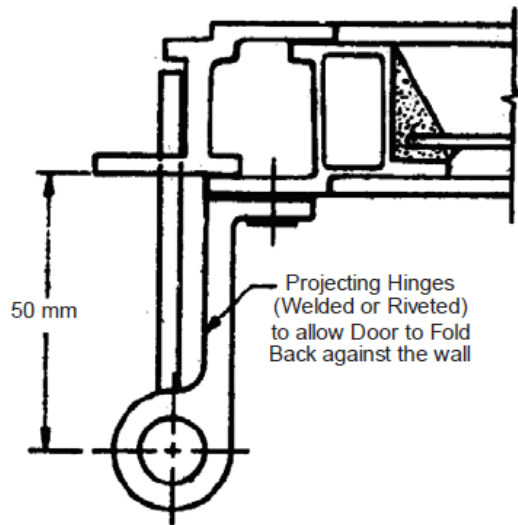


Fig. 21.23 : Typical Projecting Type Hinge for Door

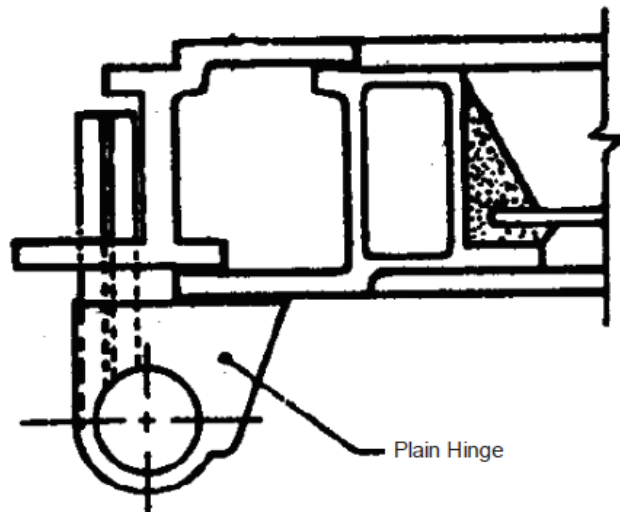
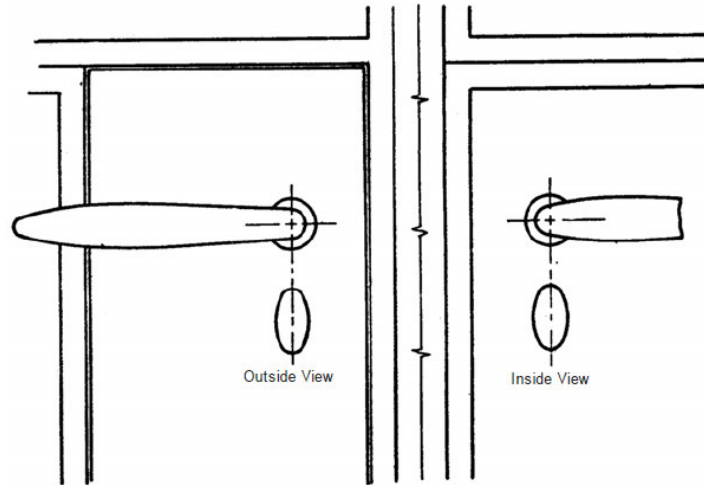


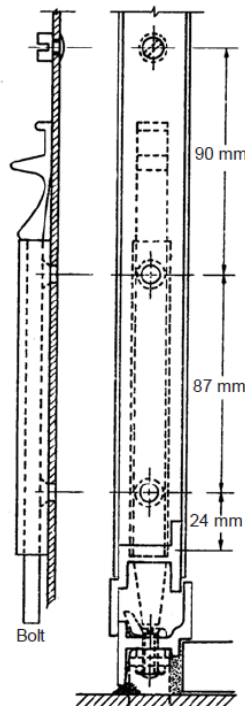
Fig. 21.24 : Typical Non-Projecting Type Hinge for Door



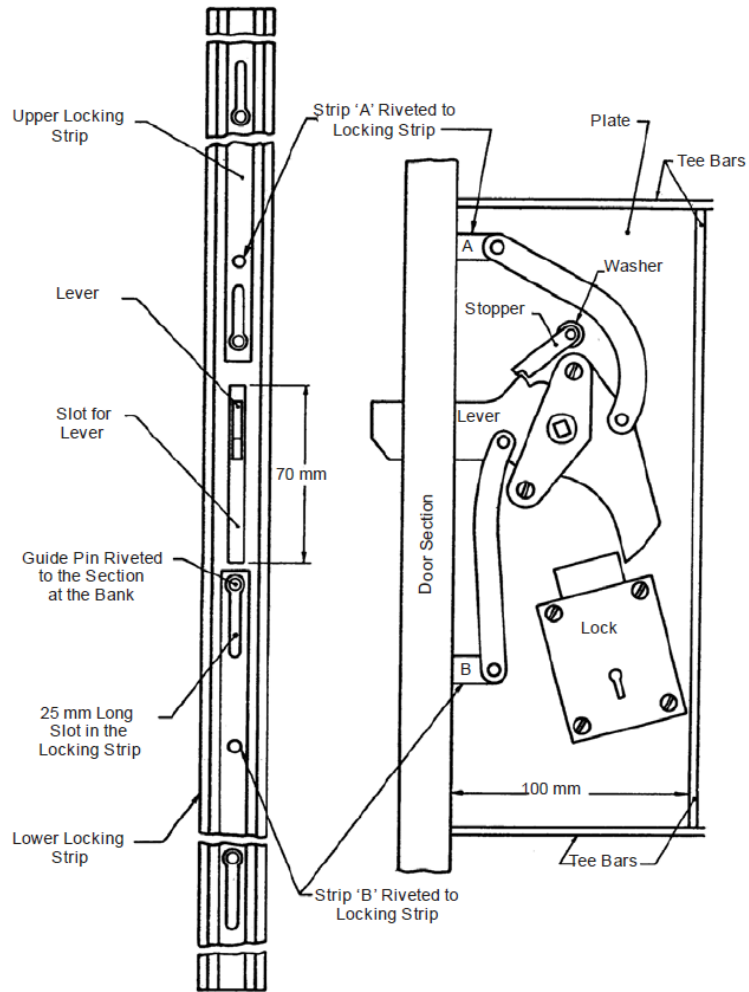
**Fig. 21.25 Typical Door Handle**

In double shutter doors the first closing shutter shall have a concealed aluminium alloy bolt at top and bottom (Fig. 21.26). It shall be so constructed as not to work loose or drop by its own weight.

Single and double shutter doors may be provided with a three-way bolting device (Fig. 21.27). Where this is provided in the case of double shutter door, concealed aluminium bolts may not be provided.



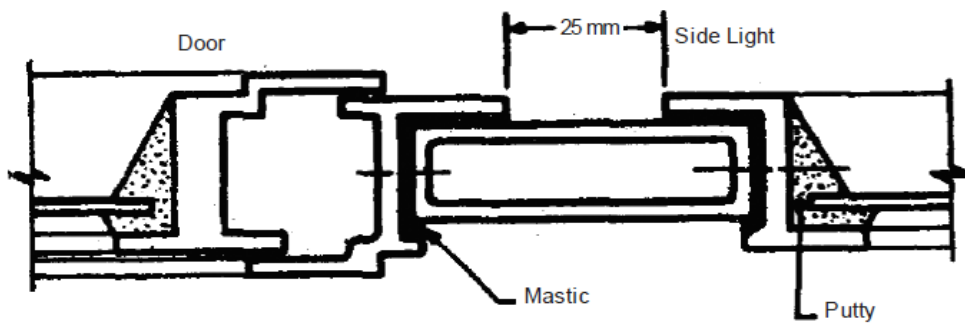
**Fig. 21.26 : Typical Vertical Bolt for Double Shutter Door**



**Fig. 21.27 : Typical Three-Way Bolting Device for**

**Doors 21.7.12 Composite Units**

The doors shall be coupled to windows or side-lights by extruded aluminium sections made from aluminium alloy conforming to IS Designation HE9-WP of IS 733. The coupling member should conform to the dimensions indicated in Fig. 21.28.



**Fig. 21.28 : Coupling Section Extruded for Coupling Door to Window or Side Light**

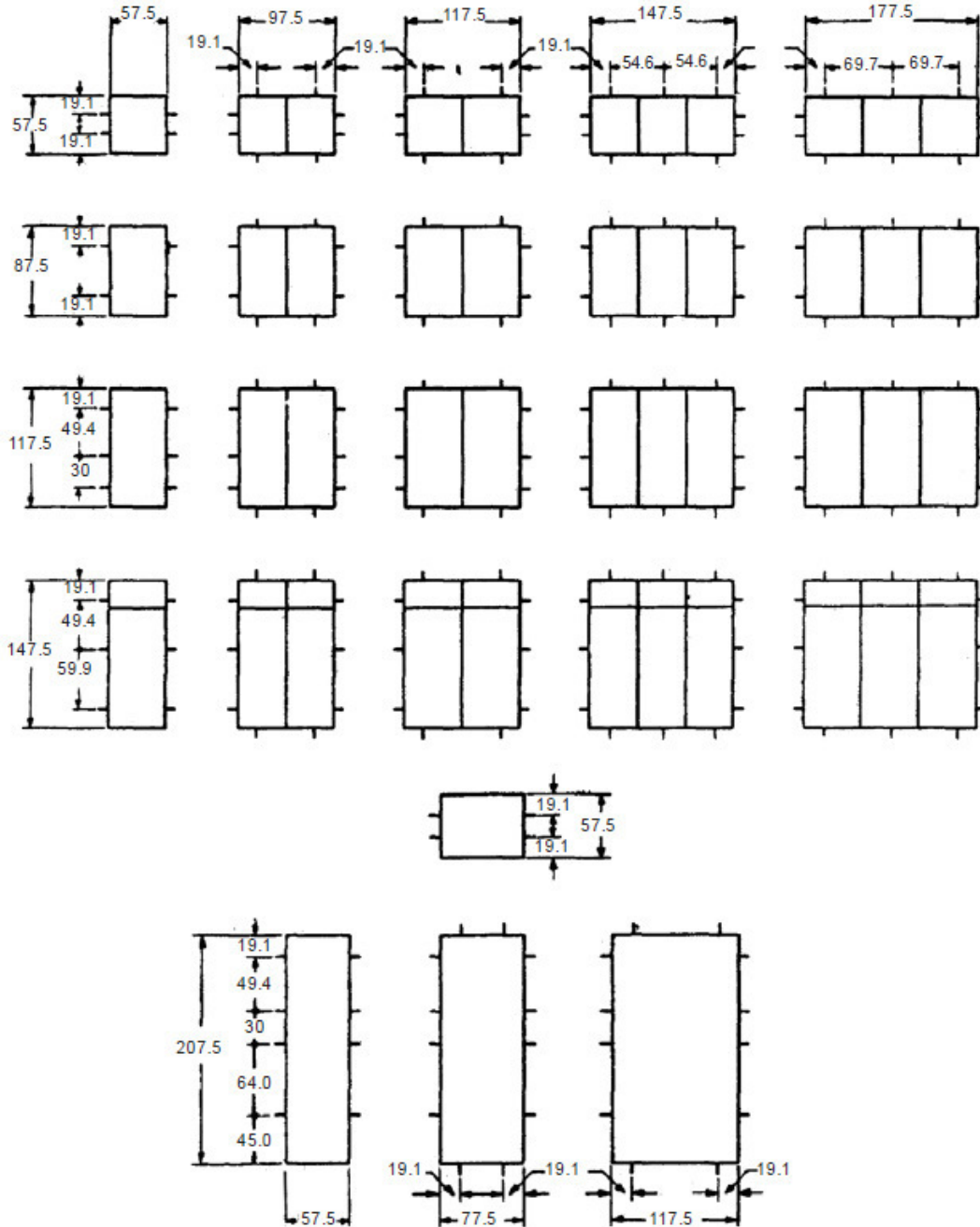


**21.7.13 Weather Bar**

Where a coupling member is fitted over an external opening shutter, the coupling member should incorporate an integrally extruded weather bar (Fig. 21.9).

**21.7.14 Position of Bolts, Fixing Screws and Lugs**

Outer frames shall be provided with fixing holes centrally in the web of the sections in the position (Fig. 21.29). Moreover, any steel lugs coming in contact with aluminium should be either galvanized or given one coat of bituminous paint.



**Fig. 21.29 : Chart Showing Approximate Position of Fixing Holes and Number of Fixing Lugs**



The fixing screws and lugs shall be as given in Table 21.7

**TABLE 21.7**

| <b>Sl. No</b> | <b>Place of Fixing</b>   | <b>Size of Screw or Lug</b>   |
|---------------|--|---|
| (i)           | To wooden frames rebated on the outside  | 30 mm x No. 10 galvanized woodscrews.   |
| (ii)          | To plugs in concrete, stone or brick work rebated on the outside                                     | -Do-  |
| (iii)         | To plugs in concrete, stone or brick work not rebated on the outside (that is plain or square jambs) | 45 mm X No. galvanized wood-screws  |
| (iv)          | Direct to brick work or masonry (that is plain or square jambs)                                      | Slotted steel adjustable lugs (natural finish) not less than 100 x 16 x 3 mm countersunk galvanized machine screws and nuts 19.0 X 6.3 mm |
| (v)           | To steel work  | Standard clips and 8 mm galvanized bolts with hexagonal nuts.   |

#### **21.7.15 Finish**

Aluminium doors, windows and ventilators may be supplied in either matt, scratch-brush or polished finish. They may, additionally, also be anodized, if so required by the Engineer-in-charge. If colour anodizing is to be done then only approved light-fast shades should be used.

A thick layer of clear transparent lacquer based on methacrylates or cellulose butyrate, shall be applied on aluminium doors, windows and ventilators by the supplier to protect the surface from wet cement during installation. This lacquer coating shall be removed after installation is completed.

#### **21.7.16 Glazing**

Glazing shall be provided on the outside of the frames

If required, glazing clips may be provided as extra fittings. Four glazing clips may be provided per glass pane, except for door type 8HS21 where the glazing clips shall be six per glass pane. In case of doors, windows and ventilators without horizontal glazing bars the glazing clips shall be spaced according to the slots in the vertical members, otherwise the spacing shall be 30 cm.

**Note:** Glazing clips are not usually provided for normal size glass panes. Where large size glass panes are required to be used or where the door or the window is located in heavily exposed situation, holes for glazing clips have to be drilled prior to fabrication and cannot be done at any later stage. Use of glazing clips, where necessary, shall be specified while placing the order.

#### **21.7.17 Packing**

All doors, windows and ventilators shall be dispatched with the opening parts suitably secured to preserve alignment when fixing and glazing.

Fixing lugs, coupling fittings and all hardware shall be dispatched separately.

Composite windows shall be dispatched uncoupled.

#### **21.7.18 Marking**

All doors, windows and ventilators shall be suitably marked on the frames with a mark identifying the manufacturer and the type.

The units may also be marked with the BIS Certification Mark.

## **21.8 FITTINGS**

### **21.8.1 Stainless Steel Friction Stay**

The stainless steel friction stays of make approved by the Engineer-in-Charge shall be used. The SS friction stays shall be of grade AISI-304 and of sizes specified in nomenclature of item.

### **21.8.2 Lockable Handles**

The lockable handle shall be of make approved by the Engineer-in-Charge and of required colour to match the colour of powder coated /anodized aluminium window sections.

### **21.8.3 Hydraulic Floor Spring**

The hydraulic floor spring shall be heavy duty double action floor spring of make approved by the Engineer -in-Charge suitable for door leaf of weight minimum 100 kg. The top cover plate shall be of stainless steel, flushing with floor finish level. The contractor shall cut the floor properly with stone cutting machine to exact size & shape. The spindle of suitable length to accommodate the floor finish shall be used. The contractor shall give the guarantee duly supported by the company for proper functioning of floor spring at least for 10 years.

### **21.8.4 Tubular Handle**

The tubular handle bar shall be aluminium polyester powder coated minimum 50 micron to required colour/anodized AC 15. Outer dia of tube shall be 32 mm, tube thickness 3.0 mm and centre to centre length 2115 mm  $\pm$  5 mm.

### **21.8.5 Measurement**

Refer Para 21.6.3.

### **21.8.6 Rate**

Refer Para 21.6.4.

## **21.9 LOUVERS**

Aluminium extruded sections (anodized or power coated) are used for providing Louvers in aluminium door, window & partition for ventilation.

### **21.9.1 Fabrication**

Refer Para 21.6.1.

### **21.9.2 Measurements**

Refer Para 21.6.3.

### **21.9.3 Rate**

Refer Para 21.6.4.

## **21.10 HERMETICALLY SEALED UNIT**

Insulating glass shall be a double glazed unit comprising two sheets of float glass panes separated by a spacer, hermetically sealed using primary and secondary sealants. The design of insulating glass system shall consist of:

**(a) Hollow Spacer Bar**

The hollow aluminium spacer bar shall be of required size and shape and shall be colour anodized. The spacer bar shall have two lines of perforations in the inner surface.

**(b) Desiccant**

The desiccant shall be Neftomol 3 A Chemetall or equivalent.

The desiccant filled in the aluminium spacer bar shall be synthesized crystalline compounds of Aluminium Hydroxide, Caustic Soda and Sodium Silicate which absorbs water molecules. The desiccant shall be of 3 A size (A means Angstrom). The quantity of desiccant used shall not be less than 35 gm/m length of spacer bar. Filled spacer bar frame shall not be stored for more than 6 hours before assembly and sealing of the unit to ensure proper functioning of the desiccant. The contractor shall submit documentary proof of using the above material in the work.

**(c) Primary Sealant**

The primary sealant shall be single component approved by the Engineer in Charge, thermo plastic solvent free sealing compound based on polysosutylene. The sealant surface shall be free from cavities, depression and other defects. The contractor shall submit documentary proof of using the above material in this work.

**(d) Secondary Sealant**

The secondary sealant in double glazed unit shall be silicone sealant approved by the Engineer in Charge. The contractor shall submit documentary proof of using the above material in this work to the entire satisfaction of Engineer-in-Charge. Before application of silicone/ polysulphide, the surface must be cleaned and free from oil, grease, dust and other loose matter. The surfaces shall be cleaned with alcohol or other suitable solvents. Detergent or soap shall not be used to clean the surfaces. The polysulphide shall be mixed and applied mechanically using automatic mixing machine in the manner approved by Engineer-in-Charge.

**Measurement**

The height and width of double glazed/single glazed unit (the area of glass unit outside the snap beading shall only be measured) as fixed in place shall be measured correct to one centimeter and area calculated in sqm. correct to second place of decimal shall be taken for payment.

**Rate**

The rate shall include the cost of all the materials, labours involved in all the operations as described in nomenclature of item and particular specification.

**21.11 BRASS LOCK**

This should generally conform to IS-2209. The size of the lock shall be denoted by the length of the body towards the face and it shall be 100 mm. the measured length shall not vary more than 3 mm from the specified length. Ordinary lever mechanism with not less than 2 levers shall be provided. False lever shall not be used. Lever shall be fitted with one spring of phosphor- bronze or steel wire and shall withstand the test as provided in IS-2209. Locking-bolt spring and strike plate shall conform to IS 2209. Two keys shall be provided with each lock.

**21.12 MACHINE MOULDED ALUMINIUM COVERING OVER EXPANSION**

**21.12.1 Material**

The material to be used shall be wrought aluminium and aluminium alloy sheet confirming to IS 737 having anodic coating of AC-15 as per IS 1868 and epoxy/ polyester powder coating of minimum 50 microns and not more than 120 microns at any point. The anodic coating and epoxy/ polyester powder coating shall be of approved colour and shade as directed by the Engineer-in-charge.

The cover plate should be made of wrought aluminium and aluminium alloy sheet of thickness not less than 2.5mm. The covering sheet should be moulded aluminium, machine cut and machine holed for receiving dash fasteners with single or double anti slip serrations ready to accommodate horizontal thermal movement of approved size, shape, pattern and design fixed over expansion joints on vertical surfaces/ ceilings/ floors.

Standard protective coating should be placed on aluminium surfaces which are coming in contact with cementitious material as per manufacturers specification.

### **21.12.2 Installations**

The substrates should be prepared as per drawing, instructions of the manufacturer and should account for anchors, fasteners and other accessories to cover the expansion joint. The sheet to be fixed to cover the expansion joint should be brought at site in required shade, size, shape, mould, design and pattern properly cut, milled and drilled holes in one row on one side to accommodate designated stainless steel dash fasteners of 8mm dia and 75mm long bolt including aluminium washers 2mm thick and 15mm dia at a staggered pitch of 200mm centre to centre in the receiving surface and providing expandable plastic sleeves in holes etc. complete as per direction of the Engineer-in-charge.

1. Necessary repairs with shrinkage resistant grout as required shall be used for preparing the surfaces on which the expansion joint covering is to be installed/ fixed.
2. True alignment and proper relationship to joints and adjoining finished surfaces measured from established lines and levels.
3. Adjustments should be made for differences between actual structural gap and nominal design gap due to ambient temperature at time of installation.
4. Fix ends to accommodate thermal expansion and contraction without buckling.
5. Fix stainless steel dash fasteners of 8mm dia and 75mm long with aluminium washers 2mm thick and 15mm dia at a staggered pitch of 200mm centre to centre.
6. Provide in continuous lengths for straight sections.
7. Install with hairline mitered corners where expansion joint cover assemblies change direction of abut other materials.
8. Terminate exposed ends of expansion joint cover as per direction of Engineer-in-charge.

### **21.12.3 Measurement**

The finished length and breadth of the aluminium sheet shall be measured correct to millimetres and area calculated in Sqm correct to second place of decimal. The weight calculated on the basis of actual average (average of five samples) weight of composite section in kilogram correct to the second place of decimal shall be taken for payment (weight shall be taken after anodizing).

### **21.12.4 Rate**

The rate shall include the cost of all the materials, labours involved in all the operations above and as described in the nomenclature of item and particular specification.

## **21.13 ANODISED ALUMINIUM GRILL**

### **21.13.1 Material**

The aluminium grill should be of approved designed and pattern as directed by the Engineer-in-charge. Standard aluminium section conforming to IS 733 and IS1285 for chemical composition and mechanical properties shall be used to meet the architectural requirements and designed to relevant works and shall be subject to approval of the Engineer-in-charge for technical, structural, functional and visual considerations. The stainless steel screws to be used shall be of grade AISI 304. The anodic coating shall be of grade AC15 and shall confirm to IS 6012. The permissible dimensional tolerances of aluminium sections shall be as per IS 6477 and shall be such that in no case it impairs the proper and smooth functioning/ operation and appearance of the door and window.

### **21.13.2 Fixing of Aluminium Grill**

The shop drawings for each type of openings shall be prepared by using suitable approved sections based on architectural drawings, adequate to meet the requirement/ specifications and by taking into consideration varying profiles of aluminium sections being extruded by approved manufacturers. The shop drawings shall show full size sections of doors, windows, ventilators and other openings etc. The shop drawings shall also show the details of fitting and the openings to be made for the smooth operations of that fittings. Before start of the work, all the shop drawings shall be got approved from the Engineer-in-charge.

Actual measurement of openings left at site for different type of door/window etc. shall be taken. The fabrication of the individual doors/windows/ventilators etc. shall be done as per the actual sizes of the opening left at site.

The anodised aluminium grill shall be of approved design and pattern with standard section from the approved manufacturer. The grill of required size keeping sufficient margin to be inserted inside the section shall be cut to correct size and fixed firmly in the frame with approved CP brass, aluminium or stainless steel screws of star head, counter sunk and matching size. Screws threads used in the fabrication shall confirm to IS1362. Proper opening of the size appropriate for fixing and operation of handles and other fittings shall be made by cutting the grill to the size as per direction of the Engineer-in-charge.

### 21.13.3 Measurement

The length and breadth of the grill shall be measured correct to millimetres and area calculated in Sqm correct to second place of decimal. The weight calculated on the basis of actual average (average of five samples) weight of composite section in kilogram correct to the second place of decimal shall be taken for payment (weight shall be taken after anodizing).

### 21.13.4 Rate

The rate shall include the cost of all the materials, labours involved in all the operations above and as described in the nomenclature of item and particular specification.

## 21.14 12MM THICK FRAMELESS TOUGHENED GLASS DOOR SHUTTER

### 21.14.1 Material

This is a clear 12mm toughened safety glass frameless shutter having a consulate top and bottom self closer mechanism with a pivot connecting to a discrete metal patch fitting at the top and bottom corners to the door.

### 21.14.2 Application

The 12mm thick clear toughened safety glass frameless shutter is fixed with the help of corner patch fittings. The corner patch fittings are simply a bolt through glass metal fitting requiring a corner cut out and hole in the glass. These discrete corner patch fittings provide a sleek and clean frameless look. The lock body patch fitting can also be installed where there is a necessity to provide locking arrangements for frameless shutter. The maximum size of frameless doors shutters using corner patch fittings should not exceed from 1000mm X 2400mm. Bigger size doors should not be fixed with these fittings. The figure 21.18.1 shows the fixing of frameless door shutters with top and bottom corner patch fittings.

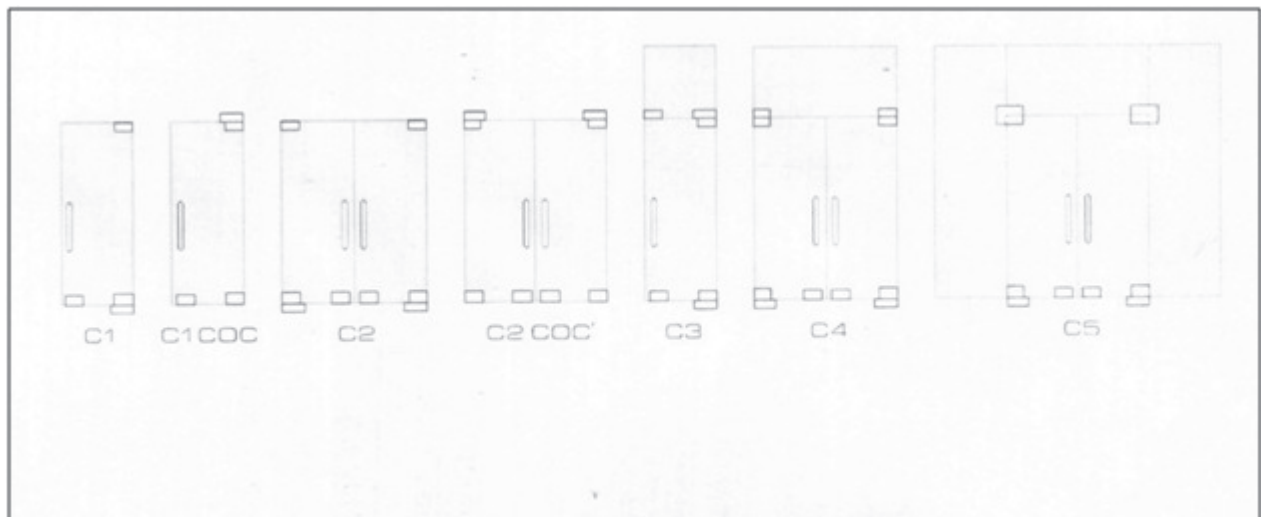


Fig. 21.30

### **21.14.3 Installation**

The frameless toughened glass door shutters of required thickness as specified in the item should be installed with the help of 304 grade stainless steel patch fittings of approved brand and manufacturer. These fittings should be complete in all respect with top and bottom pivots and double action hydraulic floor spring types fixing arrangement. These fittings should be based on a modular system, consisting of a base unit, functional inserts, and clip-on covers in a wide range of finishes. The fittings should be suitable to support the weight of the complete glass door in such a way that the movement of the door is smooth and free. The fittings should be got approved from the engineer-in-charge and all the fixings etc. shall be done as per manufacturer specification and corresponding codes described in the description of the fitting.

### **21.14.4 Measurement**

The finished final length/ height and width of the glass door should be measured correct to two places of decimal and overall area in sqm correct to two places of decimal should be calculated for payment.

### **21.14.5 Rate**

The rate shall include the cost of all the materials, labours involved in all the operations above and as described in the nomenclature of item and particular specification.

## **21.15 NON SAG ELASTOMERIC POLYURETHANE SEALANT**

### **21.15.1 Material**

A weather protective non sag elastomeric construction sealant should be one component all purpose, moisture cured, polyurethane premium grade sealant confirming to ASTM C 920 type S, grade NS, class 35. This is to, be used as specified in the nomenclature of the item in accordance with the product manufacturers specifications and as directed by the Engineer-in-charge.

### **21.15.2 Preparation of surface**

All surfaces, joints, walls must be sound, clean, dry, frost-free, and free of oil, grease and any other contaminants.

No priming is required or necessary usually. Priming is only required on the substrates which indicates the need of priming under testing conditions. In the situation where priming seems to be necessary after conducting the tests the manufacturer's technical representative should be consulted.

### **2.15.3 Masking**

Area adjacent to joints shall be masked to ensure neat sealant lines. Masking tape shall be allowed to touch clean surfaces to which the sealant is to adhere. Tooling shall be completed in one continuous stroke immediately after sealant application and before a skin forms and masking shall be removed immediately after tooling.

### **21.15.4 Application**

The closed cell backer rod of appropriate size shall be installed and the sealant should be applied in continuous operation with positive pressure adequate to fill and seal the joint. Polyurethane sealant should be gunned into joint when joint slot is at mid-point of its designed expansion and contraction. Place nozzle of gun into bottom of the joint and fill entire joint. Keep the nozzle in the joint, continue on with a steady flow of sealant preceding the nozzle to avoid air entrapment. The cartridge once opened should be used and consumed the very same day. Avoid overlapping of sealant to eliminate entrapment of air. Tool with convex profile as required and closed cell backer rod of approved quality and size is recommended to ensure full contact with joints, walls and to remove air entrapment. Remove masking tape as soon as sealant is tooled.

The closed cell backer rod is primarily a foam material with a surface skin. Make sure that backer rod is 25% larger than joint width (under compression) to offer good tooling base. The sealant should be applied by the caulking gun by putting the cartridge into the gun and putting the nozzle to the base of the joint.

**Tolerance:** A tolerance of + 3mm shall be allowed in sealant for joint filling.

#### **21.15.5 Curing**

Allow one week to cure the polyurethane construction sealant under standard condition. The contact with alcohol other solvent cleaners during cure should be avoided.

#### **21.15.6 Measurement**

The length should be measured in metres correct two places of decimal.

#### **21.15.7 Rate**

The rate shall include the cost of all the materials, labours involved in all the operations above and as described in the nomenclature of item and particular specification.

**SUB HEAD : 22.0**

**WATER PROOFING TREATMENT**





## CONTENTS

| <i>Clause No.</i> | <i>Brief Description</i>   | <i>Page No.</i> |
|-------------------|--|-----------------|
|                   | List of Bureau of Indian Standards (BIS) Codes   | 1165            |
| 22.0              | Terminology  | 1166            |
| 22.1              | Integral Cement based Treatment for Water Proofing on Horizontal Surface of Under-Ground Structure at all depths                     | 1166            |
| 22.2              | Integral Cement based Water Proofing Treatment on the Vertical Surface of Under-Ground Structures                                    | 1168            |
| 22.3              | Water Proofing Treatment to Vertical and Horizontal Surfaces of Depressed Portion of WC, Kitchen and the like                        | 1169            |
| 22.4              | Providing Water Stops  | 1170            |
| 22.5              | Water Proofing Treatment in Sunken Portion of WCs, Bathrooms etc.  | 1172            |
| 22.6              | Water Proofing Treatment on Roof Slabs   | 1173            |
| 22.7              | Integral Cement based Water Proofing Treatment with Brick Bat Coba   | 1174            |
| 22.8              | Water Proofing Treatment with Bitumen Felt   | 1176            |
| 22.9              | Grading Roof with Cement Concrete 1:2:4  | 1181            |
| 22.10             | Grading Roof with Cement Mortar  | 1182            |
| 22.11             | Water Proofing Treatment with APP (Atactic Polypropylene Polymeric) Membrane (Shifted to SH:14 as 14.49)                             | 1183            |
| 22.12             | Five Layered Water Proofing treatment with Atactic Polypropylene Polymer Modified Prefabricated Membrane (Shifted to SH:14 as 14.50) | 1183            |
| 22.13             | Extra for Covering of Atactic Polypropylene Modified Prefabricated Membrane with Geotextile (Shifted to SH:14 as 14.51)              | 1183            |

|            |  |      |
|------------|--|------|
| 22.14      | Water proofing treatment with integral crystalline admixture   | 1183 |
|            |  |      |
| 22.15      | Fibre reinforced elastomeric liquid water proofing membrane with resilient acrylic polymers                    | 1186 |
|            |  |      |
| 22.16      | Water proofing treatment with integral crystalline water proofing coating / slurry                             | 1188 |
|            |  |      |
| 22.17      | Polymer modified flexible cementitious negative side waterproofing coating with elastic waterproofing polymers | 1190 |
|            |  |      |
| 22.18      | Water proofing treatment with integral crystalline water proofing dry-shake                                    | 1191 |
|            |  |      |
| 22.19      | Crystalline water proofing mortar  | 1194 |
|            |  |      |
| 22.20      | Swellable type water stop tape   | 1196 |
|            |  |      |
| Appendix A | Bitumen Felts (Fibre Hessian Base)   | 1199 |
|            |  |      |
| Appendix B | Glass Fibre Base Bitumen Felt  | 1201 |
|            |  |      |
| Fig. 22.1  | Waterproofing of Horizontal Surface of a U.G. Structure  | 1202 |
|            |  |      |
| Fig. 22.2  | Water Proofing Horizontal Surfaces from Inside of a U.G. structure   | 1202 |
|            |  |      |
| Fig. 22.3  | Waterproofing on Vertical Surfaces of Under Ground structures  | 1203 |
|            |  |      |
| Fig. 22.4  | Position of Horizontal and Vertical Waterproofing Treatment in Sunken Portion of W.C./Kitchen and the like     | 1203 |
|            |  |      |
| Fig. 22.5  | Typical Cross-Section of PVC Water-Stop  | 1204 |
|            |  |      |
| Fig. 22.6  | Integral Cement based Waterproofing Treatment with Brick-bat Coba Over a RCC Slab                              | 1204 |
|            |  |      |
| Fig. 22.7  | Water Proofing   | 1205 |
|            |  |      |
| Fig. 22.8  | Grading Roof Slab with Cement Concrete   | 1205 |

|            |   |      |
|------------|---|------|
| Fig. 22.9  | Grading Roof with Cement Mortar 1:3/1:4   | 1206 |
|            |   |      |
| Fig. 22.10 | Grading Chhajja with Cement Mortar 1:3/1:4  | 1206 |
|            |   |      |
| Fig. 22.11 | Five Course Water Proofing Treatment with APP Modified Polymeric Membrane (Shifted to SH:14 as Fig No.14.7)     |      |
|            |   |      |
| Fig. 22.12 | Five Layer Water-Proofing Treatment with APP Modified Prefabricated Membrane (Shifted to SH:14 as Fig No.14.11) |      |



### LIST OF BUREAU OF INDIAN STANDARDS (BIS) CODES

| <i>S. No.</i> | <i>BIS. No.</i>   | <i>Subject</i>   |
|---------------|-------------------|--|
| 1.            | IS 73             | Paving Bitumen Specifications  |
| 2.            | IS 702            | Specifications for Industrial Bitumen  |
| 3.            | IS 1322           | Specifications for Bitumen felts for Water Proofing and Damp Proofing.                                     |
| 4.            | IS 2645           | Specifications for Integral Cement Water Proofing Compounds  |
| 5.            | IS 3370 (Part -1) | Code of Practice for Concrete Structures for the Storage of Liquid: Part -1 General Requirements.          |
| 6.            | IS 3384           | Specifications for Bitumen Primer for Water Proofing and Damp Proofing                                     |
| 7.            | IS 7193           | Specification for Glass Fibre Bitumen Felts  |
| 8.            | IS 12200          | Provision of Water Stops at Transfers Construction Joints in Masonry and Concrete Dams - Code of Practice. |
| 9.            | IS 12432 (Part-3) | Application for Spray Applied Insulation - Code of Practice Part-3 Polyurethane/ Polyisocyanurate          |

## 22.0 WATER PROOFING TREATMENT

### 22.0 TERMINOLOGY

#### **Water Bars**

Water bars are preformed strips of impermeable materials which are embedded in the concrete during construction.

#### **Low Partition Walls**

Parapet walls of height less than 45 cm.

#### **Expansion Joints**

Joints provided in the structure to allow for thermal expansion/construction.

#### **Blended Cement**

Cement mixed with water proofing compound in liquid or powder form.

### 22.1 INTEGRAL CEMENT BASED TREATMENT FOR WATER PROOFING ON HORIZONTAL SURFACE OF UNDER-GROUND STRUCTURE AT ALL DEPTH

#### 22.1.1 Water Proofing of Horizontal Internal Surfaces of Under-ground Structure (Fig. 22.1)

##### **(i) Preparation of Surface**

The Water Proofing Treatment over the lean concrete/levelling course surface should adhere to the surface firmly, the surface of levelling course should be roughened properly when the concrete is still green. In case the surface is not made rough before the concrete is set, the work of water proofing should not be executed till proper key is provided for the base layer of Cement Mortar 1:3.

##### **(ii) Blending Cement/Water with Water Proofing Compound**

The required quantity of cement bags to be used for a particular portion of work should be emptied on a dry platform. Water proofing compound bearing ISI mark and conforming to IS 2645 should then be mixed properly with the cement. The quantity of water proofing compound to be mixed should be as prescribed by the manufacturer but not exceeding 3% by weight of cement. The quantity of cement and water proofing compound thus mixed should be thoroughly blended and the blended cement should again be packed in bags.

For the water proofing compound in liquid form, the blending is to be done with water. This can be done by taking the just required quantity of water to be mixed in the particular batch of dry cement mortar.

The required quantity of water thus collected per batch of dry cement mortar to be prepared should be mixed with liquid water proofing compound from sealed tins with ISI mark. The water thus mixed with water proofing compound shall be thoroughly stirred so that the water is blended with water proofing compound properly.

##### **(iii) Rough Kota Stone 22 to 25 mm Thick**

The stone slabs to be used for this item shall be in thickness of 22 mm to 25 mm. Larger size of stone slabs i.e. 550 mm x 550 mm or 550 mm x 850 mm shall be used to minimise the number of joints.

General requirement of Kota stone shall be as laid down in CPWD Specifications of Kota Stone flooring.

**(iv) Preparation of Cement Slurry**

Cement slurry shall be prepared by using 2.2 kg of blended cement per sqm. area. Each time only that much quantity shall be prepared which can be covered on the surface and the surface in turn would be covered with 25 mm thick cement mortar base within half an hour. Slurry prepared and remained unused for more than half an hour shall be totally rejected.

**(v) Preparation of Cement Mortar**

Cement mortar 1:3 (1 blended cement: 3 coarse sand) shall be prepared with cement/water duly blended as explained in clause 22.1.1 (ii). Only that much quantity of cement mortar which can be consumed within half an hour, shall be prepared. Any cement mortar that is prepared and remains unused for more than half an hour shall not be used in the work and shall be rejected.

**(vi) Laying Water Proofing Course**

Before laying the base course of cement mortar 1:3, the lean concrete surface shall be cleaned neatly with water. Cement slurry prepared as per clause 22.1.1 (ii), shall be applied only on the area of the concrete surface, that can be covered with the cement mortar (1:3) base course within half an hour. The cement slurry should cover every spot of the surface and no place shall remain uncovered. Just after the application of cement slurry on the surface, the cement mortar prepared as per clause 22.1.1 (v) should be used for laying the base course. Base Course should be laid to a perfect level with wooden/aluminium straight edge of at least 2 mtrs. long. The top surface of cement mortar should be finished neatly and later scratched when green with a suitable instrument before the base course dries and gets hard that is just before the base course takes up initial set.

When the 25 mm thick base course is just getting set the cement slurry prepared as per clause 22.1.1 (iv) should be spread over the base course upto the area that shall be covered with just two to three stone slabs. The cement slurry shall be spread in such a way that the area of base course to be covered immediately shall be covered with slurry without any gap or dry spots. Immediately on applying cement slurry on the base course the Rough Kota Stone slab shall be laid over the base course and pressed gently so that the air gap can be removed. The slurry applied on the surface which gets spread when the stone slab is pressed shall get accumulated in the joints of adjacent stone slabs and if any gap still remains between the stone slabs the same should also be filled with additional quantity of cement slurry. For laying the stone slabs in perfect level, two stone slabs at adjacent concerns/ends shall be fixed firmly to the required level and a string stretched over the two slabs, the intermediate slabs shall then be set to the level of the string.

After filling all the joints of the Rough Kota stone Slabs with cement slurry the area of stone slab shall be laid with cement mortar 1:3. The surface of stone slabs shall be cleaned and lightly watered. Cement mortar 1: 3 prepared as per clause 22.1.1 (iv) shall be used for laying this course. For laying this course 25 mm high wooden strips shall be used and the top surface shall be finished smooth without using additional cement or slurry.

After laying 3rd course and before the mortar layer takes the initial set, Stone aggregate of 10 mm to 12 mm nominal size shall be uniformly spread and lightly pressed into the finished surface @ 8 cu dm./sqm. The aggregates shall not be embedded totally inside the mortar and shall be visible on the top surface.

In cases where slope is to be provided for the water proofing layer, grading with additional cement concrete/cement mortar shall be provided and then the water proofing layer shall be laid on the graded surface. Extra payment shall however be made for the grading course.



(vii) **Curing**

Immediately after completing the fourth layer, arrangements shall be made for the top RCC slab as quickly as possible and in the mean time till the top slab is casted the water proofing treatment shall be kept wet continuously. In case the concreting of slab gets delayed for more than 2 weeks the curing can be stopped after 14 days.

(viii) **Measurement**

Length and breadth shall be measured along the finished surface correct to a cm and the area shall be worked out to nearest 0.01 sqm.

(ix) **Rate**

The rate shall include the cost of all labour & materials involved in all the operations described above. The cost of grading with cement concrete / cement mortar shall be paid for separately.

**22.1.2 Water Proofing of Internal Horizontal Surfaces of Under- ground Structure (Fig. 22.2)**

Same as in 22.1.1 above except that water proofing courses will be laid on R.C.C. Slab.

**22.2 INTEGRAL CEMENT BASED WATER PROOFING TREATMENT ON THE VERTICAL SURFACE OF UNDER GROUND STRUCTURES (FIG. 22.3)**

(i) **Preparing the Surface**

The surface of the structure to be treated shall be roughed either by raking of joints in case of brick/ stone masonry or by hacking the cement concrete surface with a specifically made hacking tool just after removing shuttering. Alternately, the surface should be roughened by providing spatter dash key as explained under clause 22.1.1 (i). While doing water proofing to vertical faces from inside, it shall be ensured that water proofing treatment of floor slab is not damaged. Preferably, water proofing of vertical surface shall be done before that of horizontal surface.

(ii) **Blending Cement/Water with Water Proofing Compound** Same as under clause 22.1.1(ii).

(iii) **Rough Kota Stone Slab**

Same as explained under clause 22.1.1(iii).

(iv) **Preparation of Cement Slurry**

Same as explained under clause 22.1.1(iv).

(v) **Preparation of Cement Mortar**

Same as explained under clause 22.1.1(v).

(vi) **Laying Water Proofing Course**

Same as explained under clause 22.1.1(vi). Further rough kota stone are not sufficiently rough to remain in vertical position held by cement slurry. Therefore, the grip for the stone slab has to be increased and this can be done by planting 12 mm to 15 mm nominal size stone aggregate fixed with araldite on surface of each sand stone slab.

(vii) **Curing**

Same as explained under clause 22.1.1(vii). Further till the water proofing work on vertical face is in progress, the water proofing work done on floor slab shall be kept wet for a minimum period of 14 days. Immediately after completion of water proofing on vertical faces of side walls, the water tank shall be gradually filled with water for testing.

(viii) **Measurement**

Same as explained under clause 22.1.1(viii).

(ix) **Rate**

Same as explained under clause 22.1.1(ix).

## **22.3 WATER PROOFING TREATMENT TO VERTICAL AND HORIZONTAL SURFACE OF DEPRESSED PORTION OF WC, KITCHEN AND THE LIKE**

### **22.3.1 Before the Water Proofing Treatment**

Before the water proofing treatment, the internal plaster of ceiling and walls of WC block leaving the portion for dado/skirting should be completed. Grooving / chasing for doing the concealed work of GI/CI pipes/Electrical conduits should be completed. Cleaning the depressed/sunken portion of WC of all debris, extra mortar sticking to the vertical and horizontal surface etc. Necessary holes for 'P' trap /Nhani trap/Water escape pipe etc should be completed.

### **22.3.2 Preparing Surface and Fixing Pipes and Fittings**

Before the water proofing treatment work, proper key in the concrete surface should be provided. The depressed/sunken portion should be hacked by a hacking tool, after the concrete slab is cast and when this concrete is still green.

The vertical surfaces of the depressed /sunken portion should be hacked with a hacking tool just after the shuttering is removed.

In case of old work, the water proofing treatment on such surfaces shall be permitted after making proper spatter dash key.

Fixing the 'P' trap in position and all other pipes work including the water escape pipe shall be fixed properly and the holes should be plugged carefully before taking up the water proofing work.

### **22.3.3 1st Course**

Cement duly blended with water proofing compound as explained in clause 22.1 shall be used for preparing the cement slurry.

The consistency of the slurry should be such that 4.4 kg. of blended cement with water proofing compound is used per sq. metre area of surface to be treated. The slurry should be started from the vertical faces towards the bottom of the floor as shown in Fig. 22.4. Particular care should be taken to see that the slurry is applied to corners without leaving any gap.

### **22.3.4 2nd Course**

Immediately on applying the blended cement slurry on the surface to be treated cement plaster 20 mm thick in CM 1:3 (1 blended cement: 3 coarse sand) shall be applied both on vertical and horizontal surfaces taking particular care to complete the entire depressed/ sunken portion of WC within a day so that the plaster can be done without any joint. Junctions shall be properly rounded. The surfaces of the plaster shall be left rough but finished in one plain and cured for a week.

On completion of the curing period both horizontal and vertical surfaces shall be cleaned properly and gently and allowed to dry.

### **22.3.5 3rd Course**

Only after the surface is completely dried the blown or residual bitumen shall be applied @ 1.7 kg. of bitumen per sqm area.

### **22.3.6 4th Course**

PVC sheet 400 micron thick shall be spread evenly without any kink immediately, so that the PVC sheet sticks to the surface firmly. PVC sheet shall be continued to be laid over the main slab upto 100 mm.

Overlapping of PVC sheet should be done with a minimum overlap of 100 mm, duly pasting the overlapped sheet with an application of bitumen @ 1.7 kg./ sqm.

The projections of pipes and 'P' trap outlet etc. inside the depressed/sunken portion of WC shall also be clad with water proofing treatment layer upto a height of 150 mm, using a coat of bitumen with PVC sheet complete.

The surfaces of depressed/sunken portion of WC shall not be left without covering with specified filling material and base concrete, otherwise the PVC sheet layer may be tampered by the labour working in the vicinity.

Fixing up of WC pan, filling specified material and the top base concrete should be done as early as possible and the top horizontal layer of water proofing may be taken up later i.e. just before laying the floor tiles.

#### **22.3.7 Measurement**

Length and breadth shall be measured along the finished surface correct to a cm. and area shall be worked out to nearest 0.01 sqm. No payment however shall be made for the 100 mm overlap of PVC Sheet over the roof slab.

#### **22.3.8 Rate**

The rate shall include the cost of labour and materials involved in all operations described above.

### **22.4 PROVIDING WATER STOPS**

**22.4.1** Water stops conforming to IS 12200 for construction/expansion joints should be fabrication from a plastic compound, the basic resin of which shall be polyvinyl chloride. The compound shall contain additional resin/ plasticizer inhibitors or other materials such that when the materials is compounded it shall meet the requirement given in IS 15058.

#### **22.4.2 Type of Joints for which Water Bars are Provided**

The water bars are provided only for the movement of joints in a water retaining structure.

Different types of movement joints are as described below:

**Complete Contraction Joint:** This is a movement joint with deliberate discontinuity both in concrete as well as the reinforcement but no initial gap is maintained between the concrete on either side of the joint. This joint is intended to accommodate the contraction of the concrete.

**Partial Contraction Joint:** This is a movement joint with deliberate discontinuity in concrete but no water bar is provided and no discontinuity is provided in steel. No initial gap is maintained between the concrete on either side of joint.

**Expansion Joint:** This is also a movement joint with complete discontinuity in both reinforcement and concrete. It is intended to accommodate either expansion or contraction of the structure.

In general such joint requires the provision of an initial gap between the adjoining parts of the structure which accommodates expansion or contraction of the structure.

#### **22.4.3 Types and Performance of Water Bars**

Water bars are performed strips of impermeable material which are embedded in the concrete during construction so as to span across the joints and provide a permanent water tight seal during the whole range of joint movement.

The most usual form of water bars are strip with a longitudinal corrugation as shown in Fig. 22.5.

Another form of water bar of metallic type is Z shaped strip.

Water bars of copper, sheet lead, natural or synthetic rubber and plastic such as polyvinyl chloride (PVC) are also used. These bars comprise of central longitudinal hollow tube with thin walls and stiff wings of about 150 mm width.

Out of the metals available copper is most suitable as regards ductility, resistance to corrosion in air, water and concrete. However, it may be attacked by some wastes. If sheet lead is used it should be insulated from concrete by a good coat of bituminous or suitable composition. Natural synthetic rubber and plastics have very considerable advantage in handling, splicing and in making intersections.

Galvanized iron sheets may also be used with the specific permission of the Engineer-in-charge provided the liquid stored or the atmosphere around the liquid retaining structure is not excessively corrosive i.e. sewage.

The strip water bars described as above, while placing in position has to be passed through the end shutter of the first placed concrete with the result the shuttering at this point should be perfectly water tight otherwise cement slurry may escape from the concrete being laid and will ultimately weaken the structure. Therefore to avoid the above problem one can prefer moulded type of water bar.

The design of the moulded water bar with several projections need to be passed through the end shutter while placing the same in position. Another main advantage of this water bar is that since it occupies bigger proportion of the thickness of the joint it would lengthen the shortest alternative water path through the concrete.

**22.4.4** It is important to ensure proper compaction of concrete around the water bar. Proper cover to all the reinforcement shall be maintained. Sometimes to increase the bond the holes are provided in the copper water bars but in the long run it proves to be disadvantageous as it shortens the path of water through concrete. Water bars should be placed at the centre of the wall or if it is to be provided away from the centre its distance from either face of the wall shall not be less than half of the width of water bar or as specified/directed by the Engineer-in-charge.

#### **22.4.5 Covers Plates for Joint**

Sometimes joint cover plates have to be used for expansion joints mainly to avoid the risk of a fault in the water bar which is embedded. The plates to be used should be either copper or sheet lead. In case the copper plates are to be used, it should be clamped to the concrete face on each side of the joint. To ensure water tightness suitable gasket shall be used. Joint cover plates of sheet lead are also used and fixed on the joints. In this case the edges may return into grooves formed in the concrete and can be made completely water tight by lead caulking. Faces of the concrete to which sheet lead is to be fixed should be painted with bituminous or other suitable composition and the lead sheet should be similarly coated before fixing.

#### **22.4.6 Spacing of Joints**

In Reinforced Concrete floors movement joints should be spaced at not more than 7.5 m apart in two directions at right angles. The wall and floor joints should occur at the base of the wall in which case corresponding vertical joint is not important.

In concrete walls, the vertical movement joints should normally be placed at a maximum spacing of 0.75 m in reinforced walls. The maximum length desirable between vertical movement joints will depend upon the tensile strength of the walls and may be increased by suitable reinforcements.

Amongst the movement joints in floors and walls as mentioned above, expansion joint should be normally be provided at spacing of not more than 30 m between successive expansion joints or between the end of the structure and the next expansion joint, all other joints being of the contraction type.

In case of expansion joints the filling of these with bitumen filler, bitumen felt or any such material etc. shall be paid for separately in running metre. The measurement shall be taken upto two places of decimal stating the depth and width of joint.

In case joint cover plates either of copper or sheet lead with ancillaries are provided, these shall be measured and paid for separately.

#### **22.4.7 Measurement**

Length shall be measured correct to a cm and net quantities shall be calculated upto two places of decimal.

Each category of water stops/bar such as PVC, copper specifying width, thickness shall be measured and paid for separately.

#### **22.4.8 Rate**

The rate shall include all labour and materials in all the operations described above.

### **22.5 WATER PROOFING TREATMENT IN SUNKEN PORTION OF WCs, BATHROOMS ETC.**

#### **22.5.1 Preliminaries to be Attended**

The preliminaries shall be attended as described in clause 22.3.1.

#### **22.5.2 Preparing Surface, Fixing Pipes and Fittings**

In this case, unlike as described in clause 22.3.2, no hacking of surface need be made, but only extra mortar sticking to the surface should be removed and the surface should be cleaned thoroughly. Fixing 'P' trap etc. shall be done as described in Clause 22.3.2.

#### **22.5.3 Providing and Laying of Slurry for First Layer**

The consistency of the slurry should be such as to cover the desired area by using 0.488 kg of blended cement per sqm of area.

On deciding the correct quantity of water required per sqm. area the required quantity of slurry should be prepared which can be applied over the desired surface within half an hour of mixing with 0.488 kg. of grey cement + 0.253 kg. water proofing compound as per manufacturer specifications + x litres of water per sqm. area and the required quantity of slurry thus prepared should only be used for first application.

The first layer shall be applied with painting brushes over the specified and dampened area carefully including the corners, holes on the surfaces and joints of pipes in concrete etc. and the application should continue at least upto 150 mm height of fixtures of pipes from the surface. The surface on application shall be air cured for 4 hours.

#### **22.5.4 Providing and Laying of Slurry for Second Layer**

The quantity of slurry required for second application to be covered within an hour of mixing shall be prepared with 0.242 kg. cement + 0.126 kg. water proofing compound + y litres of water per sqm. area and the required quantity of slurry thus prepared should only be used for second application.

The application of 2nd layer of slurry is same as for first layer as detailed in clause 22.5.3.

The applied surface shall be allowed to air cure for 4 hours and thereafter water curing shall be done for full 48 hours.

In case no further work as described above is to be taken up immediately on completion of water proofing treatment due to any reason it is recommended to protect the treated portion with cement plaster 1:4 as a protective layer for which separate payment shall be made to the contractor.

#### **22.5.5 Measurement**

Length and breadth shall be measured along the finished surface correct to a cm and area shall be worked out to nearest 0.01 sqm.

#### **22.5.6 Rate**

The rate shall include the cost of all labour and materials involved in all the operations described above. The cost of plastering shall be measured and paid for separately.

### **22.6 WATER PROOFING TREATMENT ON ROOF SLABS**

**22.6.1** Before taking up the water proofing work the construction of parapet walls, including finishing should be completed. Similarly, the ancillary items like haunches, khurras, grooves to tack the fibre cloth layer, fixing up of all down take pipes, water pipes and electric conduits etc. should be completed and no such work should be allowed on the area to be treated during the progress of water proofing treatment or even later.

#### **22.6.2 Preparing Surface**

There is no necessity of hacking the surface but the surface to be treated shall be cleaned including removing the mortar dropping from the surface.

#### **22.6.3 Providing and Laying of Cement Slurry**

The procedure to prepare and apply the cement slurry shall be same as detailed in clause 22.5.3 except that over projected pipes etc. slurry shall be applied just upto 100 mm height instead of 150 mm height. The slurry shall be applied upto a height of 300 mm on parapet walls and in the groove where the fibre glass cloth is to be tucked.

#### **22.6.4 Providing and Laying of Fibre Glass Cloth (2nd Layer)**

The fibre glass cloth shall be of approved brand and shall be thin, flexible uniformly bonded mat composed of chemically resistant borosilicate glass fibre distributed in random open porous structure bonded together with a thermosetting resin.

Immediately on applying the slurry on a sufficiently workable area as detailed above in clause 22.6.3 when the slurry applied is still green the fibre glass as specified shall be spread evenly on the surface without any kink and pressed in such a way that no air spaces exist. The fibre glass cloth shall be taken upto a height of 30 cm on parapet walls and tucked in the groove specially prepared at that height.

A minimum overlap of 100 mm width shall be provided when the fibre cloth has to be joined. The joining of 100 mm overlap shall be done with the same slurry used for the application on surface as first layer. The fibre cloth shall also be extended upto a height of 100 mm over pipes projecting from the surface.

#### **22.6.5 Providing and Laying of Cement Slurry for Third Layer**

The quantity of water required to prepare slurry which can cover one sqm. area of the surface to be treated shall be calculated as described in clause 22.5.3 and consider this quantity as say x litres/sqm.

On deciding the correct quantity of water required, the slurry shall be prepared by mixing 1.289 kg/m<sup>2</sup> of grey cement + 0.67 kg./sqm. of Water Proofing Compound +1.289 kg./sqm. of coarse sand + x litres of water. Slurry shall be prepared for the area to be covered within half an hour of mixing.

The consistency of the slurry shall be such that in one application with a brush 1.5 mm thickness of slurry can be coated on the fibre glass cloth surface.

This slurry shall be applied evenly on the entire surface covered with fibre glass cloth so that a layer of 1.50 mm thickness of slurry is formed.

The application of slurry shall be continued over the 300 mm portion of parapet wall and also the portion tucked in the groove on top.

The entire surface shall be allowed for air curing for 4 hours and later the surface shall be cured with clean water for 7 days.

On completion of curing the grooves where the fibre glass cloth is tucked shall be closed neatly with cement mortar mixed with water proofing compound and the repaired surface should be cured by clean water for 7 days.

Fourth and final layer of brick tiling if required shall be laid and paid for separately.

#### **22.6.6 Measurement**

Length and breadth shall be measured along the finished surface correct to a cm and area shall be worked out to nearest 0.01 sqm. Overlaps and tucking in a flashing grooves shall not be measured. No deductions shall be made for openings or recess or chimney stack, roof lights or Khurras of area upto 0.40 sqm, nor anything extra shall be paid for forming such openings, recess etc. For area exceeding 0.40 sqm. deduction will be made in the measurement for the full opening and nothing extra shall be paid for making such opening.

#### **22.6.7 Rate**

The rate shall include the cost of labour and material involved in all the operations described above, however the cost of brick layer with cement mortar shall be paid for separately.

### **22.7 INTEGRAL CEMENT BASED WATER PROOFING TREATMENT WITH BRICK BAT COBA (Fig. 22.6)**

**22.7.1** Before taking up the work the preliminaries to be attended shall be exactly same as described in clause 22.6.1.

#### **22.7.2 Preparing the Surface**

The surface of the slab should be roughened by scrapping when the slab concrete is still green, however, the surface need not be hacked. In case the slab is already cast and surface fairly finished, the same shall be cleaned neatly of all mortar droppings, loose materials etc with brooms/cloth.

#### **22.7.3 Providing and Laying of Slurry under Base Coat**

The quantity of water required to prepare the slurry with 2.75 kg. of blended cement to be painted over an area of 1 sqm. shall be calculated exactly as described in clause 22.5.3.

Depending upon the area of surface that has to be covered, the required quantity of slurry should be prepared using 2.75 kg. blended cement + water per sqm. area to be covered, taking particular care to see that only that much quantity of slurry shall be prepared which can be used within half an hour of preparation i.e. before the initial setting time of cement.



The prepared slurry shall be applied over the dampened surface with brushes very carefully, including the joints between the floor slab and the parapet wall, holes on the surfaces, joints of pipes, masonry/concrete etc.

The application of the slurry should continue upto a height of 300 mm on the parapet wall and also the groove as shown in Fig. 22.6. The slurry should also be applied upto a height of 150 mm over pipe projections etc.

#### **22.7.4 Laying Base Coat 20 mm thick**

Immediately after the application of slurry and when the application is still green, 20 mm thick cement plaster as base coat with cement mortar 1:5 (1 blended cement : 5 coarse sand) shall be evenly applied over the concrete surface taking particular care to see that all the corners and joints are properly packed and the application of the base coat shall be continued upto a height of 300 mm over the parapet wall.

#### **22.7.5 Laying Brick Bat Coba**

Brick bat of size 25 mm to 115 mm out of well burnt bricks shall be used for the purpose of brick bat coba.

The brick bats shall be properly dampened for six hours before laying.

Brick bats shall be laid to required slope/gradient over the base coat of mortar leaving 15-25 mm gap between two bats. Cement mortar 1:5 (1 blended cement: 5 coarse sand) shall be poured over the brick bats and joints filled properly. Under no circumstances dry brick bats should be laid over the base coat.

The haunches/gola at the junction of parapet wall and the roof shall be formed only with brick bat coba as shown in Fig. 22.6.

In case the brick bat coba is laid on the base coat immediately on initial set there will be no necessity of applying cement slurry over the base coat before laying the brick bat coba. However, if the brick bat coba is to be laid on the subsequent day, cement slurry prepared as described in clause 22.7.3 shall be applied over the top surface of the base coat, then only the brick bat coba shall be laid.

#### **22.7.6 Application of Slurry over Brick Bat Coba**

After two days of curing of brick bat coba cement slurry prepared as per clause 22.7.3 shall be applied on the surface of brick bat coba. The application of slurry shall be the same as described in clause 22.5.3 which should cover the haunches/gola, and the remaining small portion of parapet wall and also inside the groove as shown in the figure.

#### **22.7.7 Laying Finishing Layer (Protective Coat)**

Immediately on applying the cement slurry over the surface of the brick bat coba and when the slurry applied is still green, the fibre glass cloth as specified in clause 22.6.4 shall be spread evenly on the surface without any kink & pressed to see that no air spaces exist. The fibre glass cloth shall be taken up to a height of 300 mm on parapet walls & tucked in the groove specially prepared at that height. 20 mm thick layer of cement plaster, without leaving any joints shall be applied with cement mortar 1:4 (1 blended cement: 4 coarse sand) over the entire fibre glass cloth including the haunches/gola and the small portion on the parapet wall. The groove in the parapet wall over the haunches shall also be filled neatly packing the mortar firmly in the groove.

The surface of the finishing layer (protective coat) shall be neatly finished with cement slurry prepared as per clause 22.7.3. The finished surface shall be allowed to dry for a while and then pattern of 300 mm x 300 mm groove, 8 mm deep shall be made over the entire surface.



### 22.7.8 Curing and Testing the Treatment

The entire surface thus treated shall be flooded with water by making kiaries with weak cement mortar, for a minimum period of two weeks.

### 22.7.9 Measurement

The measurement shall be taken along the finished surface of treatment including the rounded and tapered portion at junction of parapet wall. Length and breadth shall be measured correct to a cm and area shall be worked out to nearest 0.01 sqm. No deduction in measurement shall be made for openings or recesses or chimney stacks, roof lights or khurras of area upto 0.40 sqm., nor anything extra shall be paid for making such openings, recesses etc. For areas exceeding 0.40 sqm., deduction will be made in the measurements for the full openings and nothing extra shall be paid for making such openings.

### 22.7.10 Rate

The rate shall include the cost of all labour and materials involved in all the operations described above.

## 22.8 WATER PROOFING TREATMENT WITH BITUMEN FELT

**22.8.0** Water proofing treatment with self finished felt shall be four courses or six courses as described in the item. Four course water proofing treatment with self finished felt is a normal duty treatment suitable for buildings where the cost of roof treatment is required to be restricted.

Six course water proofing treatment with self finished felt is a heavy duty treatment suitable for important structures.

### 22.8.1 Materials

**22.8.1.1** Self finished felt (Appendix A and B) shall conform to the type and grade given in the description of the item. This shall be one of the following types:

- (i) Type 3 grade 1 hessian base felt conforming in all respects to IS 1322.
- (ii) Type 2 grade 1 fibre base bitumen felt conforming to IS 1322.
- (iii) Type 2 grade 2 glass fibre base felt conforming in all respects to IS 7193.

**22.8.1.2 Bonding Materials:** This shall consist of blown type petroleum bitumen conforming to IS 702 or residual petroleum bitumen conforming to IS 73. The bonding material shall be so selected as to withstand the local condition of temperature and gradient satisfactorily. The penetration of bitumen used shall not exceed 40 in any case. Suitable residual type petroleum bitumen of penetration 30/40 (IS grade S-35), residual type petroleum bitumen with higher penetration and low softening point and suitable blown type petroleum bitumen of IS grade 85/25 or 90/15 of approved quality shall be used.

Where proprietary brands of bonding materials are proposed to be used they shall conform in all respects to the specifications in the preceding paras.

| Sl.No | Description  | 1st course | 3rd course | 5th course |
|-------|--|------------|------------|------------|
|       |  | kg/sqm     | kg/sqm     | kg/sqm     |
| I.    | Four course treatment:   | 1.45       | 1.45       | -          |
| II.   | Six course treatment:  |            |            |            |
|       | (a) With type 3 grade 1 hessian base self finished bitumen felt. | 1.45       | 1.20       | 1.45       |
|       | (b) With felts other than type 3 grade 1 hessian base.           | 1.45       | 1.20       | 1.70       |

**22.8.1.3 Stone Grit and Pea- sized Gravel:** Stone grit shall be 6 mm and down size. Where pea-sized gravel is used it shall be hard, round and free from dust, dirt etc. The stone grit or pea-sized gravel shall not be spread over vertical and sloping faces of flashings and at drain mouths. At these places the surface shall be painted with two coats of bituminous solution.

The quantity of stone grit or pea-sized gravel required for the final course of four or six course treatment with hessian base self finished bitumen felt type 3 grade 1 shall be 6 cubic decimeter/ sqm.

## **22.8.2 Preparation of Surface**

**22.8.2.1** The surface to be treated shall have a minimum slope of 1 in 120. This grading shall be carried out with cement concrete or cement plaster with coarse sand, as per direction of Engineer-in-charge, to the average thickness required and finished smooth. Such grading shall be paid for separately.

**22.8.2.2** Junctions between the roof and vertical faces of parapet walls, chimneys etc. shall be cased by running triangular fillets 7.5 x 7.5 cm size, in cement concrete. At the drain mouths, the fillets shall be suitably cut back and rounded off for easy application of water proofing treatment and easy flow of water. Cement concrete where used shall be 1:2:4 mix (1 cement: 2 coarse sand : 4 graded stone aggregate 20 mm nominal size). The provision of fillets shall be deemed to be covered by the item of water proofing and shall not be measured or paid for separately.

**22.8.2.3** In existing roof where gola and drip course are provided at the junction of roof and vertical face of parapet wall, chimney stacks etc., these shall be dressed suitably and finished smooth so as to ensure an easy and gradual turning of the flashing. Any dismantlement or forming and finishing smooth the junction for forming the base of the flashing shall not be measured or paid for separately and shall be deemed to form part of the preparation of the surface in the water proofing treatment.

**22.8.2.4** While the grading of roof surface is being done, it shall be ensured that the outlet drain pipe have been fixed and mouth at the entrance have been eased and rounded off properly for easy flow of water.

**22.8.2.5** When any pipe passes through the roof to be treated, angular fillet of shape shown in Fig. 22.7 shall be built around it for the water proofing treatment to be taken over it. These fillets shall not be measured or paid for separately.

**22.8.2.6** For carrying over and tucking in the water proofing felts into the parapet walls, chimney stacks etc. a horizontal groove 6.5 cm deep, 7.5 cm wide section with its lower edge at not less than 15 cm above the graded roof surface shall be left on the inner face of the same during construction if possible. When such groove has not been left, the same shall be cut out neatly and the base at rear of the groove shall be finished smooth with cement plaster 1:4 (1 cement: 4 coarse sand). Such cutting of the groove and its finishing smooth shall be deemed to be part of the water proofing item and shall not be measured or paid for separately. No deduction shall be made either for not making the groove or when the later has already been left in the masonry by the construction agency.

**22.8.2.7** Tucking in the water proofing felt will be required where the parapet wall exceeds 45 cm in the height from the graded surface. Where the height is 45 cm or less, no groove will be required as the water proofing treatment will be carried over the top of the parapet wall to its full thickness. In the case of low dividing walls of height 30 cm or less, outlets therein shall be cut open for full height and the bottom and sides shall be rendered smooth and corners rounded and such treatment shall not be measured and paid for separately.

**22.8.2.8** Where expansion joints are left in the slab, the provision of dwarf walls and/or RCC slabs for covering them and finishing the surface smooth shall be the responsibility of the construction agency, which had laid the roof slab and will not be included the operation of water proofing.

**22.8.2.9** The graded surface of the roof and concrete fillets and the faces of walls shall be thoroughly cleaned with wire brushes and all loose scales etc. removed. The surface shall then be dusted off. Any crack in the roof shall be cut to 'V' section, cleaned and filled up flush with cement mortar slurry 1:4 (1 cement: 4 coarse sand) or blown type petroleum bitumen of IS grade 85/25, or approved quality conforming to IS 702. Such cleaning of the surface or treating the cracks shall not be paid for separately.

### **22.8.3 Priming Coat**

Where so specified, or required by the Engineer- in-Charge for example under slightly damp conditions a priming coat consisting of a bitumen primer conforming to IS 3384 should be applied with brush on the roof and wall surface at 0.24 litres per sqm to assist adhesion of the bonding material (i.e. bitumen).

Such application of primer shall be paid for separately, unless specifically included in the water proofing item.

### **22.8.4 Underlay**

Where a floating treatment of water proofing with self finished bitumen felt is required i.e. where water proofing treatment is required to be isolated from the roof structure, a layer of bitumen saturated felt (underlay) shall be spread over the roof surface and tucked into the flashing groove. No bonding material shall be used below the underlay in order to keep the underlay free of the structure. The adjoining strips of the underlay shall overlap to a minimum of 7.5 cm at sides and 10 cm at ends. The overlaps shall be sealed with the same bonding material as used for the self finished felt treatment. Unless specifically included in the water proofing item, the underlay treatment shall be paid for separately.

The underlay shall be of type 1 saturated felt conforming to IS 1322 in all respects and having a total minimum weight of the finished bitumen felt in dry condition with mica dusting powder @ 6.8 kg per 10 sqm. The roll shall not be damaged or crack on being unrolled on a fairly smooth and flat surface.

### **22.8.5 Treatment**

**22.8.5.1** The water proofing shall consist of a four or six course treatment, as given in the description of the item, each layer of bonding materials, self finished bitumen felt or stone grit or pea sized gravel being counted as a course.

**22.8.5.2** The choice of a four or six course treatment will depend on the climatic condition, the importance of the building, the durability required, cost and other relevant considerations.

**22.8.5.3** A four course treatment shall consist of the following layers:

- (a) Initial layer of bonding material applied hot at specified weight per unit area.
- (b) 2nd layer of self finished bitumen felt conforming to the type and grade given in the description of the item.
- (c) Third layer of bonding material.
- (d) Final layer of stone grit of pea sized gravel spread at specified volume of material per unit area.

**22.8.5.4** In a six course treatment, the first, second and third layer shall be of the same as in the four course treatment. The fourth and fifth layer shall consist of self finished felt and bonding material respectively. The sixth layer shall consist of stone grit or pea sized gravel.

**22.8.5.5** The primer or underlay where required to be provided shall not count against the number of courses specified.

## **22.8.6 Laying**

**22.8.6.1** Bitumen bonding material of required grade shall be heated to the working temperature specified for the particular grade by the bitumen manufacturers and conveyed to the roof in buckets or pouring canes in weighed quantities.

Suitable working temperature for different grades of bitumen are as under:

- (i) Blown type petroleum bitumen of IS grade 85/25 or 90/15 - 180 degree C.
- (ii) Residual type petroleum bitumen of penetration 30/40 - 180 degree to 190 degree C (IS grade S-35).

**22.8.6.2** Drain outlets shall be given a four or six course treatment as specified for the roof in the description of the item in the manner specified for the flat roof surface. Water proofing treatment shall be carried into the drain pipe or outlets by at least 10 cm. The water proofing treatment laid on the roof surface shall overlap the upper edge of the water proofing treatment in the drain outlets by at least 10 cm.

**22.8.6.3** The self finished felt shall be cut to the required length, brushed clean of dusting material and laid out flat on the roof to eliminate curls and subsequent stretching. The felt shall normally be laid in length at right angles to the direction of the slope and laying shall be commenced at the lowest level and worked upto crest. The felt shall not be laid in single piece of very long lengths as they are likely to shrink; 6 to 8 m are suitable lengths. The roof surface shall be cleaned and dried before the felt treatment is begun. Each length of felt shall be laid in position and rolled up for a distance of half its length. The hot bonding material shall be poured on the roof across the full width of the rolled felt as the latter is steadily rolled out and pressed down. The pouring shall be so regulated that the correct weight of bonding material per unit area is spread uniformly over the surface. Excess bonding material that gets squeezed out at the ends shall be levelled up as laying proceeds. When the first half of the strip of felt has been bonded to the roof, the other half shall be rolled up and then unrolled on the hot bonding material in the same way. Subsequent strips shall also be laid in the same manner. Each strip shall overlap the preceding one by at least 7.5 cm at the longitudinal edges and 10 cm at the ends. All overlaps shall be firmly bonded with hot bitumen. Streaks and trailings of bitumen near edges of laps shall be levelled by heating the overlap with a blow lamp and levelling down unevenness.

The third layer of bonding material in the four course treatment shall be carried out in a similar manner after the flashing has been completed.

**22.8.6.4** In a six course treatment the third and fourth layers of bonding material and self finished felt shall be laid in the manner already described, taking care that laps in the felt are staggered from those in the second layer. The fifth layer of bonding material shall be carried out after the flashing is done (See Fig. 22.7).

**22.8.6.5 High Parapet Walls, Chimney Stacks etc.:** Felts shall be laid as flashings wherever junctions of vertical and horizontal surfaces occur. Longitudinal laps shall be 10 cm. The lower layer of flashing felt in a six course treatment shall overlap the roof water proofing by not less than 20 cm while the upper layer shall overlap the roofing felt by 10 cm. The minimum overlap of the flashing felt in four course specification over the roofing felt shall be 10 cm.

The flashing shall consist of the same four or six course treatment as for the roof except that the final course of stone grit or pea-sized gravel shall be replaced by an application of bituminous solution of approved quality in two coats on the vertical and sloping faces only, of the flashing. The overlap along the length of flashing shall stagger with those in the second layer of flashing felt (in a six course treatment and with the joints in the roof felt).

The upper edge of the flashing felt shall be well tucked into the flashing grooves in the parapet, chimney stacks etc. to a depth of not less than 6.5 cm. Corresponding applications of bonding material shall also be made. The flashing treatment shall be firmly held in place in the grooves with wood edges at intervals and the grooves shall be filled up with cement mortar 1:4 (1 cement: 4 coarse sand) or cement concrete 1:2:4 (1 cement : 2 coarse sand : 4 graded stone aggregate 6 mm nominal size) and surface finished smooth with the rest of the wall. The cement work shall be cured for 7 days. When dry, the exposed plaster joints of grooves shall be painted with bitumen and two coats of bituminous solution shall be applied on the vertical and sloping surface of flashing (see Fig. 22.7).

After the top flashing felt layer has been fixed, the penultimate layer of bonding material shall be applied over the roofing felt and the horizontal overlaps and vertical and sloping surfaces of the flashings at the specified rate. Stone grit or pea sized gravel shall then be spread uniformly over the hot bonding material on the horizontal roof surface at the specified quantity per unit area and pressed into it with a wooden roller.

**22.8.6.6 Low Parapet Walls:** Where parapet walls are of height 45 cm or less, bitumen felt flashings shall be provided in the same manner as for flashings in the case of high parapet walls except that the upper edge shall be carried upto the full height of the wall and taken right across the top of the parapet and down on the external vertical faces to a minimum distance of 5 cm (see Fig. 22.7).

**22.8.6.7 Low Dividing Walls:** Where low dividing walls or inverted beams are met with, the same shall be covered with a four or six layer treatment as for the main roof, the latter bearing carried down both sides of the wall and overlapping the roofing treatment as in the case of flashing of high parapet walls (see Fig. 22.7).

Drain outlets where formed in the low dividing walls, shall be given water proofing treatment of the same number of courses as specified for the flat roof surface. The bottom and sides shall be so treated that all overlaps are in the direction of flow of drainage.

**22.8.6.8 Expansion Joints:** Where the expansion joints are provided in the slabs, the joints and their cover slabs shall be suitably treated with water proofing. A typical sketch of an expansion joint with the RCC slabs on either side of the joint turned vertically up and covered with precast RCC cover slabs as given in Fig. 22.7. The cover slabs shall cover the vertical turned up dwarf walls by not less than 7.5 cm and are provided with throatings on their underside along their length. The water proofing treatment shall be taken up the sloping junction fillets and the vertical faces of the walls to the underside of the cover slabs. The cover slabs are given the water proofing treatment like the roof slabs, after the cross joints between adjacent cover slabs are first sealed with 15 cm width of roofing felt struck to them with bitumen. The water proofing treatment shall be carried down the sides of the cover slabs to their full thickness. Care shall be taken to see that overlaps if any in the roofing over the cover slabs stagger with the joints between cover slabs.

The formation of the expansion joints and provision of cover slabs shall be the responsibility of the construction agency. The formation of the junction fillets and the water proofing treatment of the joint and cover slabs shall be carried out by the water proofing agency. No extra shall be paid for the junction fillers or for the sealing of the cross joints in the cover slab with 15 cm width of bitumen strips.

**22.8.6.9 Pipes:** Where vertical pipe outlets are met with 7.5 x 7.5 cm fillets of lime or cement concrete of the type and section shown in Fig. 22.7 shall be provided and flashing of four or six course treatment, same as for the roofing treatment shall be laid.

The upper edge of the flashing shall be laid sloping down forward and butted against the pipe and annular depression so formed shall be filled with hot bitumen. A circular metal collar in the shape of an inverted truncated cone shall be fixed on the pipe to throw off the rain water clear of the flashing and this shall be paid for separately.

**22.8.6.10 Terrace:** Where roof surfaces are expected to be used precast cement concrete tiles or 40 mm thick cement concrete shall be laid on the water proofing treatment. In such cases, the final course of stone grit or pea sized gravel shall not be laid in the water proofing treatment. Suitable adjustment in the rates will be effected for not providing the stone grit or pea sized gravel layer. Cement concrete in situ flooring shall be laid in panel not exceeding 0.4 square metres each. Precast tiles or in situ concrete flooring where laid shall be paid for separately unless included in the description of the water proofing item.

### **22.8.7 Measurements**

**22.8.7.1** Length and breadth shall be measured correct to a cm. The area shall be calculated in square metres correct to two places of decimal.

**22.8.7.2** Measurements shall be taken over the entire exposed area of roofing and flashing treatment including flashing over low parapet walls, low dividing walls and expansion joints and at pipe projections etc. Overlaps and tucking into flashing grooves shall not be measured.

**22.8.7.3** Vertical and sloping surfaces of water proofing treatment shall also be measured under the four or six course treatment as the case may be, irrespective of the fact that the final course of grit or pea sized gravel is replaced by bitumen primer.

**22.8.7.4** Primer or saturated felt underlay, where provided, shall also be measured in the same manner as the water proofing treatment and paid for separately. No deduction in measurements shall be made for either openings or recesses for chimney stacks, roof lights and the like, for areas upto 40 square decimetre (0.4 sqm) nor anything shall be paid for forming such openings.

For similar areas exceeding 40 sq. decimetre deductions will be made in measurements for full opening and nothing extra shall be paid for forming such openings.

### **22.8.8 Rate**

The rate shall include the cost of all labour and materials involved in all the operations described above and the particular specifications given under the different items, with the corrections noted in the relevant sub-paras.

## **22.9 GRADING ROOF WITH CEMENT CONCRETE 1:2:4**

### **22.9.1 Materials**

Cement, coarse sand and graded stone aggregate 20 mm nominal size, shall be used as specified in the item.

The specifications for the materials and method of preparation of concrete shall conform in general to the specification described in sub-head 4.0 of CPWD Specifications.

**22.9.1.1 Laying:** Before laying cement concrete for grading, the level markings to the required slope/gradient shall be made only with cement concrete on the surface of the slab at suitable spacing with the help of string and steel tape (Measuring tape) so that the mason can lay the concrete to the required thickness, slope / gradient easily in between the two level markings.



On getting the level marking approved by the Site Engineer the surface should be sprinkled with thick cement slurry and the concrete should be laid carefully, without throwing from height, in predetermined strips.

The concrete should be consolidated by specially made wooden tamping. After the tamping is done the surface should be finished to required slope/gradient with wooden trowels without leaving any spots of loose aggregates etc.

The mixed cement concrete must be laid in position, within half an hour of its mixing. In case any quantity of concrete remains unused for more than half an hour the same should be rejected and removed from the site.

**22.9.1.2 Finishing:** The slope of finished terrace shall not be more than 1 in 120 unless a steeper slope is desired by the Engineer-in-Charge.

The minimum thickness of the concrete at its junction with Khurra or parapets shall be 5 cm. The concrete shall be rounded at the junction of roof slab and parapet. It is desirable to provide a haunch/gola/filler at the junction of the parapet wall and the roof slab as shown in Fig. 22.8.

The finished concrete surface shall present a smooth surface with correct slopes and uniform rounding. The concrete should be free from cracks. Excess trowelling shall be avoided.

**22.9.1.3 Thickness:** Average thickness shall be as per clause 22.9.1.2 as shown in Fig. 22.8.

**22.9.1.4 Curing:** Curing shall be done either by spreading straw/Hessian cloth over the graded surface, keeping the same wet for full 10 days or flooding the graded area with water by making kiaries with weak cement mortar, for 10 days. Occasional curing by simply spraying water now and then shall not be permitted under any circumstances.

**22.9.1.5 Measurement:** Length and breadth shall be measured correct to a cm. Area shall be worked out to nearest 0.01 sqm. and the cubical contents shall be worked out to nearest 0.001 cum.

No deduction shall be made for either opening or recesses for chimney stacks, roof lights etc., Khurra for area upto 0.1 sqm. Nothing extra shall be paid either for any extra material or labour involved in forming such opening or recess or in rounding the concrete function of roof with parapet walls, chimney stack, khurra etc.

**22.9.1.6 Rate:** The rate shall include the cost of all the materials and labour involved in all the operations described above.

## **22.10 GRADING ROOF WITH CEMENT MORTAR**

### **22.10.1 Materials**

Cement and coarse sand shall be as specified in the item of work or as described in sub-head 3.0 of CPWD Specifications.

**22.10.1.1 Cement Mortar :** Cement mortar 1:3 (1 cement: 3 coarse sand) /1:4(1 cement: 4 coarse sand) specified in the item of work shall conform to the specification described in sub-head 3.0 of CPWD Specifications.

**22.10.1.2 Preparation of the Surface:** The surface shall be cleaned properly with brooms brush, cloth to remove all dirt, dust, mortar droppings.

**22.10.1.3 Laying:** Same as described in clause 22.9.1.1, except that cement mortar shall be tamped with wooden and steel trowels and surface finished with steel trowel.

**22.10.1.4 Finishing**

- (i) The slope of finished surface shall not be more than 1 in 120 unless a steeper slope is specified in the item of work.
- (ii) The finished surface of the grading shall present a smooth surface with correct slopes and uniform roundings wherever they are provided. The mortar surface shall be free of cracks. Excess trowelling shall be avoided.

**22.10.1.5 Thickness:** The minimum thickness of cement mortar grading at the junction with khurra or parapet wall shall be 20 mm. The cement mortar shall be rounded at the junction of roof slab and parapet. It is desirable to provide a haunch/gola/filler at the junction of parapet wall and the roof slab. The maximum thickness that shall be adopted for grading with cement mortar shall be 50 mm. It is not at all desirable to lay the cement mortar grading for greater thickness and in that case it is advised to go in for grading with Cement Concrete. The average thickness shall be as shown in Fig. 22.9 and 22.10.

**22.10.1.6 Curing:** Curing for the grading with cement mortar shall be done exactly as described in clause 22.9.1.4.

**22.10.1.7 Measurement:** Same as specified in clause 22.9.1.5.

**22.10.1.8 Rate:** The rate shall include the cost of all the labour and material involved in all the operations described above.

**22.11 Clause shifted to Sub Head 14 (Repairs to Buildings) as clause no. 14.49**

**22.12 Clause shifted to Sub Head 14 (Repairs to Buildings) as clause no. 14.50**

**22.13 Clause shifted to Sub Head 14 (Repairs to Buildings) as clause no. 14.51**

**22.14 WATER PROOFING TREATMENT WITH INTERGRAL CRYSTALLINE ADMIXTURE**

**22.14.0 General**

One method that can simplify the protective process is to make concrete with Integral Crystalline Admixtures that reduce its permeability in effect to make the concrete itself waterproof. Apart from the regular workability admixtures, Integral Crystalline durability admixtures shall be added to all concrete, structural and otherwise, to waterproof & enhance the Concrete Durability. The Crystalline Admixture shall be added either at the time of batching at the batching plant or in the drum of the transit mixer, when the concrete arrives the point of pouring.

The concrete water proofing industry redefined their terminology a short time ago. American Concrete Institute (ACI) 212-3R-10 "Report on Chemical Admixture for Concrete" documents devoted chapter 15 / page 46 to permeability reducing admixtures (PRA's) that outlines PRAH & PRAN classification or differentiates between those suitable for concrete exposed to Non Hydrostatic Conditions (PRAN) and concrete exposed to Hydrostatic Conditions (PRAH). Besides reducing permeability some PRA's impart other beneficial characteristics such as reduced drying shrinkage, reduced chloride-ion penetration, improved freeze thaw resistance and enhanced autogenous sealing.

**22.14.1 Material**

Integral crystalline water-proofing admixture is one part cementitious powder added to the concrete mix at the time of batching. Integral crystalline water-proofing admixture consists of **hydrophilic chemicals** such as Portland cement, very fine treated silica sand and various active, proprietary chemicals. These active chemicals react with moisture in fresh concrete and with the by-products of cement hydration to cause a



catalytic reaction, which generates a non-soluble crystalline formation throughout the pores and capillary tracts of the concrete. Thus, the concrete becomes permanently sealed against the penetration of water or liquids from any direction. The concrete is also protected from deterioration due to harsh environmental conditions. Integral crystalline water-proofing admixture is specially formulated to meet varying project and temperature conditions. This reaction continuous over the life of the concrete serving to seal not only initial shrinkage cracks, but also cracks that occur over time.

#### **22.14.2 Technical Specifications / Parameters**

The specifications of the materials should match or exceed the requirements as mentioned in nomenclature of the item.

The water proofing compound used in integral crystalline water proofing treatment shall satisfy all the requirements indicated in relevant standards or as specified in concerned relevant codes etc. and the same shall be got tested and get approved from the Engineer-in-charge before its use at site of work.

The integral crystalline waterproofing admixtures of **hydrophilic in nature** shall confirm to the following requirements:

1. Dosage as specified in the nomenclature of item or higher as recommended by manufacturer's specification. The material shall fulfill the requirements of American Concrete Institute Guidelines ACI-212- 3R-10 Chapter 15 or European norms EN 934-2-T2 and fall under PRAH (Permeability reducing Admixtures for HYDROSTATIC conditions) and shall be capable of withstanding/resistant to 16 bar hydrostatic pressure and reduce Coefficient of Permeability of concrete by more than 90, when compared to controlled concrete and tested as per DIN 1048 Part 5 or EN 12390-8 by carrying out 4 cycles each of 5 bar hydrostatic pressure for 72 hours and drying for 48 hours between the cycles. The co-efficient of Permeability calculated as per Darcy's Formula/ Valenta equation by incorporating penetration values obtained at the end of fourth cycle pressure.
2. The crystalline admixture shall be compatible with any other concrete admixture confirming to ASTM C494, EN 934-2 or IS 9103.
3. The performance of the crystalline admixture must not be restricted by water-cement ratio of concrete mix. In other words, the crystalline admixture must perform at any water-cement ratio of the concrete mix.
4. The integral crystalline admixture shall possess CE approval as per EN934-2 and shall be procured from CE approved manufacturing unit. It shall also possess approval certificate from any national apex institution mandated to issue design codes. The product has no corrosion effect on reinforcement steel according to test norm DIN V18998. The maximum chloride content less than 0.1% and maximum alkali content less than 9.3%.
5. In addition to recognizing the use of Integrate Crystalline Admixtures. ACI 212-3R-10 has also provided some guideline in para 15.3-"Selection and Evaluation" to select the best quality PRAH's materials as maximum permeability reducing admixtures at maximum Hydrostatic Pressure. Para 15.3 stated that the effect of the admixture can be evaluated by testing the permeability of concrete both directly and indirect methods. The US Army Corps of Engineers CRC C48-92 (1992) test method is a direct measurement of concrete permeability resistance during exposure to water under **200 psi or 13.8 bars or 1.38 MPa of hydrostatic pressure.**
6. The integral crystalline admixture must reduce Chloride diffusion Co-efficient by minimum 45% when tested as per ASTM C 1556-4 and compared with the controlled concrete, thereby prolonging the durability & service life of the treated concrete structure.
7. The integral crystalline admixture must be capable of self-healing of cracks up to a width of 0.5mm.

8. The integral crystalline admixture performance shall not be affected by wear abrasion of the treated concrete surface and crystalline treated concrete shall not require protection layer.
9. The integral crystalline admixture shall be non-toxic and shall confirm to NSF-61 USA or any other similar certification from reputable international or local third party or declaration of performance certificate supervised by a reputable European/US third party.
10. The integral crystalline admixture when used in the concrete will have no detrimental side effect interms of Alkali Silica Reaction (ASR) and corrosion of steel reinforcement etc.
11. The manufacturer shall submit guarantee in respect of crystalline admixture performance for 10 years against any leakage.

**Note:** The manufacturer shall submit test certificates in respect of all above said specification/ parameters of Integral Crystalline Admixture Material from reputed National/International laboratories as per relevant codes. To support the claim of crystal formation, national/ international test report of scanning electrons microscopic (SEM) photographs dandified and mature crystal formation to plug all the capillary track and pores of the concrete shall be provided.

Total quantity of Integral Crystalline Admixture Material required shall be arranged at site of work only after obtaining the prior approval of the Engineer-in-Charge in writing. Proper account of water proofing compound used in the work shall be maintained. It shall be ensured that the consumption of the compound is as per specified requirements. The contractor shall associate himself with anyone of the applicator of water proofing compound duly approved by the Engineer-in-Charge before start of work relating to the water proofing treatment.

#### 22.14.3 Recommended uses

|   |                                  |
|---|----------------------------------|
| Foundations/Rafts                                 | Reservoirs, Bridges and Dams     |
| Sewage and Water Treatment Plants                 | Secondary Containment Structures |
| Tunnels and Subway Systems                        | Underground Vaults               |
| Parking Structures                                | Swimming Pools and water tanks   |
| Pre-Cast, Cast-in-situ and Shotcrete applications | Basement Retaining Walls         |

#### 22.14.4 Dosage

0.8% (minimum) to the weight of cement content per cubic meter of concrete or higher dosage as recommended by the manufacturer's specification in reinforcement cement concrete at site of work.

#### 22.14.5 Mixing

The integral crystalline admixture shall be used @ 0.8% (minimum) to the weight of cement content per cum of concrete or higher as recommended by the manufacturer's specification desired to meet water proofing and durability criteria. Integral crystalline Admixture must be added to the concrete at the time of batching at the batching plant or in the drum of the transit mixer, when the concrete arrives the point of pouring.

The sequence of procedures for addition will vary according to the type of batch plant operation and equipment. The mixing shall be followed as below unless & until specified otherwise. For any detailing and mixing guidelines the manufacturer's specifications should be followed.

##### 22.14.5.1 Ready mix plant- Dry batch operation

Add integral crystalline admixture in powder form to the drum of the ready-mix truck under the batch plant and add 60%- 70% of the required water, along with required aggregate. Mix the materials for 2-3 minutes to ensure that the integral crystalline admixture is distributed evenly throughout the mix water. Add the balance of materials to the ready-mix truck in accordance with standard batching practices.

#### **22.14.5.2 Ready mix plant- Central mix operation**

Mix integral crystalline admixture with water to form a very thin slurry (e.g. 18kg of powder mixed with 22.7 litre of water) or recommended by the manufacturers specification. Pour the required amount of material into the drum of the ready-mix truck. The aggregate, cement, sand and water should be batched and mixed in the plant in accordance with standard practices (taking into account the quality of water that has already been placed in the ready-mix truck). Pour the concrete into the truck and mix for at least 5 minutes to ensure even distribution of integral crystalline admixture throughout the concrete.

#### **22.14.5.3 Precast batch plant**

Add integral crystalline admixture to the aggregate and sand, then mix thoroughly for 2-3 minutes before adding the cement and water. The total concrete mass should be blended using standard practices.

It is important to obtain a homogeneous mixture of integral crystalline admixture with the concrete. Therefore dry integral crystalline admixture powder should never be mixed directly to wet concrete as this may cause clumping and hence thorough dispersion in the concrete mix may not occur.

#### **22.14.5.4 Setting time and strength**

The setting time of concrete mix is directly affected by the chemical and physical composition of ingredients, temperature of the concrete and prevailing climatic conditions. Retardation of set may occur when using integral crystalline admixture. The amount of retardation will depend upon the concrete mix design and the dosage rate of integral crystalline admixture. However, under normal conditions, integral crystalline admixture will provide a normal set concrete. Concrete containing integral crystalline admixture may develop higher ultimate strengths than plain concrete. Trial mixes of the concrete should be carried out under project conditions to determine setting time and strength of the concrete.

#### **22.14.6 Precaution / Special Consideration**

When incorporating Integral Crystalline Admixture, the temperature of the concrete mix should be above 6°C for at least 24 hours from casting.

#### **22.14.7 Storage / Shelf Life**

Integral Crystalline Admixture must be stored dry at a minimum temperature of 7°C and its self life is one year when stored under proper conditions. The product/material should be stored under dry condition. The self life of the integral crystalline admixture shall be treated as one year when stored under normal conditions.

#### **22.14.8 Measurement**

The quantity i.e. weight of Integral Crystalline Admixture will be measured in kilogram correct to two places of decimal.

#### **22.14.9 Rate**

The rate shall include the cost of all labour and materials involved in all the operations described above.

### **22.15 FIBRE REINFORCED ELASTOMERIC LIQUID WATER PROOFING MEMBRANE WITH RESILIENT ACRYLIC POLYMERS**

#### **22.15.1 Material**

Fibre reinforced elastomeric liquid water proofing membrane is a ready-to-use waterproofing, white product, with high solar reflectance and Sun Reflectivity Index (SRI) of 105, for external applications. This is made from resilient acrylic polymers and synthetic resins in water dispersion, and when dry forms a continuous, flexible waterproofing membrane. This is resistant to all atmospheric conditions and UV rays, and guarantees long-lasting protection for the substrate.

#### **22.15.2 Technical Specification/ Parameters:**

1. Fibre reinforced elastomeric liquid water proofing membrane with fibers in water emulsion with high reflectance and emissivity with a solar reflectance index SRI of 105 should comply with the requirements of EN 1504-9 ("Products and systems for protecting and repairing concrete structures:

definitions, requirements, quality control and conformity assessment. General principles for the use of products and systems”) EN 1504-2 coating (C) principles PI, MC and IR (“Concrete surface protection systems”).

2. This should possess a paste like consistency having highly reflective white colour.
3. This should have density of 1.35 with dry solid content of 61.4%.
4. This should have minimum tensile strength of 1.0N/mm<sup>2</sup> as per ISO 37 or ASTM D-412.
5. This should conform to results after testing as per EN1062-11 for exposure to artificial weather conditions.
6. The Sun Reflectivity Index when tested as per ASTM E1980 should be 105 minimum.
7. Elongation at break (% age) of 150 % minimum as per ASTM D-412.
8. Adhesion strength is more than 1.0 N/mm<sup>2</sup> as per ASTM D-4541.

### **22.15.3 Applications**

It is to be applied using a long-haired roller, brush or spray on any horizontal, sloping or vertical surfaces to form a strong, flexible, tack-free dry surface, suitable for occasional light foot traffic. This can withstand normal expansion and contraction stresses caused by temperature variations due to its flexibility. This also helps lower the working temperature of roofs and guarantees good energy performance properties of all the layers of the roof.

### **22.15.4 Preparation of Surface**

All the substrates, whether they are new or old, must be sound, clean, dry and free of all traces of oil, grease, old paint, rust, mould and any other material which could compromise the bond. Application temperature may be from 7°C to 40°C.

Concrete and in general mineral substrates must be sound and dry with no rising damp. Any loose parts must be removed with wire brushes. All wax, water-repellent treatments, etc. must be removed from the surface of ceramic substrates with a suitable detergent and/ or by sanding. Any hollows and gaps in the surface must be repaired properly with appropriate material as described and instructed by the manufacturer of this product. The tools to be used must be properly cleaned.

### **22.15.5 Application Procedure**

All the area of operation shall be thoroughly cleaned as described in para 22.15.3 above. Mix the content in such a manner that they are perfectly blended into a homogenous state of liquid which can be applied by long haired roller or airless spray. The fibre reinforced elastomeric liquid water proofing membrane with resilient acrylic polymers shall be applied on top of concrete roof in three coats @ 10.76 litre/10 sqm or more as recommended by manufacturer specification. One coat i.e. first coat of self priming elastomeric water proofing liquid. The material shall be diluted with water in the ratio of 3:1 (3 parts of elastomeric water proofing liquid and 1 part of water). Wait until the first coat is completely dry and becomes slightly darker in colour. After the first coat has dried completely apply second coat with undiluted elastomeric water proofing liquid in a cross direction to the previous coat. After the drying of second coat completely apply the final coat of undiluted elastomeric water proofing liquid in a direction perpendicular to previous coat. The overall dry film thickness should not be less than 500 microns or more as specified in manufacturer specification. Protect the membrane from rain unless it is completely dry. The overall consumption of the material should be as per nomenclature of the item and should also adhere to the specifications detailed in the approved schedule of the manufacturer.

### 22.15.6 Measurement

The length and breadth/ height shall be measured in running metre correct to two places of decimal and the area of applications should be measured in sqm correct to two places of decimal.

### 22.15.7 Rate

The rate shall include the cost of all the labour and material involved in all the operations described above.

## 22.16 WATER PROOFING TREATMENT WITH INTEGRAL CRYSTALLINE WATER PROOFING COATING / SLURRY

### 22.16.0 General

This Integral crystalline water proofing coating / slurry of **hydrophilic in nature** is applied to surface of the concrete to water proof and protect the concrete in-depth. It consists of Portland cement, specially treated quartz sand and a compound of active chemicals. Integral crystalline water proofing coating material needs only to be mixed with water prior to application.

When integral crystalline water proofing material is applied to a concrete surface, the active chemicals react with moisture and the by-products of cement hydration to cause a catalytic reaction that generates an insoluble, crystalline structure. These crystals fill the pores and minor shrinkage cracks in the concrete to prevent any further water ingress (even under pressure). However, integral crystalline water proofing material will still allow the passage of vapor through the structure (i.e. the concrete will be able to "breathe"). Even after the concrete has cured, integral crystalline water proofing material remains dormant in the concrete and will reactivate in the presence of moisture to seal capillary tracts and hairline cracks.

In addition to water proofing the structure, integral crystalline water proofing slurry protects concrete against seawater, wastewater, aggressive groundwater and many other aggressive chemical solutions. Integral crystalline water proofing material is approved for use in contact with potable water and is therefore suitable for use in water storage tanks, reservoirs, water treatment plants, etc.

### 22.16.1 Material:

This Integral crystalline water proofing material consists of Portland cement, specially treated quartz sand and a compound of active chemicals.

The water proofing compound used in integral crystalline water proofing treatment shall satisfy all the requirements indicated in relevant standards or as specified in concerned relevant codes etc. and the same shall be got tested and get approved from the Engineer-in-charge before its use.

### Technical Specification/ Parameters:

The integral crystalline slurry / coating material of **hydrophilic in natural** shall confirm to the following requirements:

1. Dosage as specified in the nomenclature of item or higher as recommended by manufacturer's specification. The material shall fulfill the requirements of American Concrete Institute Guidelines ACI-212- 3R-10 Chapter 15 or European norms EN 934-2-T2 and fall under PRAH (Permeability reducing Admixtures for HYDROSTATIC conditions) and shall be capable of withstanding/resistant to 16 bar hydrostatic pressure and reduce Coefficient of Permeability of concrete by more than 90, when compared to controlled concrete and tested as per DIN 1048 Part 5 or EN 12390-8 by carrying out 4 cycles each of 5 bar hydrostatic pressure for 72 hours and drying for 48 hours between the cycles. The co-efficient of Permeability calculated as per Darcy's Formula/ Valenta equation by incorporating penetration values obtained at the end of fourth cycle pressure.
2. It shall confirm to EN1504-3 (For structural repairs-R3, Compressive Strength >25MPa) supplied from an approved manufacturing unit having CE approval confirming to EN1504-3R3.
3. The product has no corrosion effect on reinforcement steel according to test norm DIN V18998. The maximum chloride content less than 0.1%.

4. The Integral Crystalline Slurry must be capable of self-healing of cracks up to a width of 0.5mm.
5. The crystalline water proofing coating/slurry, when used in the concrete, will have no detrimental side effects in terms of Alkali Silica Reaction (ASR), corrosion of Steel Reinforcement etc.
6. The product performance shall not be affected by wear abrasion of the treated concrete surface and crystalline treated concrete shall not require protection layer.
7. The crystalline water proofing coating/slurry shall be non toxic and suitable for use in potable water facilities- NSF listed as per ANSI 61 listing or DVGW-W347, Germany or equivalent and a declaration of performance certificate supervised by a reputed European/US third party.
8. The manufacturer shall submit guarantee in respect of crystalline water proofing coating/slurry performance for 10 years against any leakage.

**Note:** The manufacturer shall submit test certificates in respect of all above said specifications/parameters of Integral Crystalline water proofing slurry material from reputed National/International laboratories as per relevant codes.

Total quantity of the Integral Crystalline water proofing slurry material required shall be arranged at site of work only after obtaining the prior approval of the Engineer-in-Charge in writing. The proper account of water proofing compound used in the work shall be maintained. It shall be ensured that the consumption of the compound is as per specified requirements. The Contractor shall associate himself with anyone of the applicator of water proofing compound duly approved by the Engineer-in-Charge before start of work relating to the water proofing treatment.

#### 22.16.2 Recommended uses

|   |                                  |
|---|----------------------------------|
| Foundations/Rafts                                 | Reservoirs, Bridges and Dams     |
| Sewage and Water Treatment Plants                 | Secondary Containment Structures |
| Tunnels and Subway Systems                        | Underground Vaults               |
| Parking Structures                                | Swimming Pools and water tanks   |
| Pre-Cast, Cast-in-situ and Shotcrete applications | Basement Retaining Walls         |

#### 22.16.3 Preparation of surface

All concrete to be treated with integral crystalline water proofing slurry material must be clean and have an "open" capillary surface. Remove laitance, dirt, grease, etc. by means of high pressure water jetting, wet sand blasting or wire brushing. Faulty concrete in the form of cracks, honeycombing, etc. must be chased out, treated with the same material and filled flush with the mortar mixture as specified by the manufacturer. Surface must be carefully pre-watered prior to the application of integral crystalline water proofing material. The concrete surface must be damp but with no wet sheen on the surface.

#### 22.16.4 Mixing

Integral crystalline water proofing slurry / coating material should be mechanically mixed with clean water to a creamy consistency resembling to thick oil. Only that much material should be mix as can be used within 20 minutes and mixture should be stirred frequently. The mixture should not be allowed to set, if it happens, simply re-stir to restore workability but no more water should be added to it. The ratio of integral crystalline water proofing material with water should be as below

- (i) **Vertical surface:** - For applying with brush the mixing ratio shall be 5 parts of integral crystalline water proofing coating material to 2 parts of water.
- (ii) **Horizontal surface:** - The ratio should be 3 parts of Integral Crystalline water proofing coating material to 1 part of water. This should be applied by brush only.



### 22.16.5 Application Procedure

The slurry mix of the Integral Crystalline water proofing slurry material shall be applied in one or two coats as specified/ required according to work situation in the item. After preparation of surface as described in para 22.16.3, and making the surface saturated with water before application of Crystalline Slurry, then first coat of the slurry mix shall be applied by the brush or appropriate power spray equipment. The second coat as specified shall be applied while the first coat is still green.

The other method of application known as dry powder consistency can also be applied on horizontal surfaces only. The specified amount of integral crystalline water proofing material is distributed in powder form through a sieve or a semi mechanical barrow spreader and troweled into the freshly placed concrete as this reaches the initial set.

The integral crystalline water proofing material to be used shall be as following:-

- (i) **Vertical surface:** - Two coats of integral crystalline water proofing material slurry coat shall be applied @ of 0.70 kg per sqm. per coat or more as specified by the manufacturer specification.
- (ii) **Horizontal surface:** - One coat of integral crystalline water proofing material slurry coat shall be applied @ of 1.10 kg per sqm or more as specified by the manufacturer specification to harden concrete. Alternatively integral crystalline water proofing material mix can be dry sprinkled @ of 1.10 kg per sqm and trowel applied to fresh concrete when it has reached initial set.
- (iii) **Construction joint:** - Integral crystalline water proofing material mix shall be applied either as slurry coat or dry powder consistency immediately prior to placing the next lift/ bay of concrete @ 1.60 kg per sqm. or more as specified by the manufacturer specification.
- (iv) **Binding concrete:** - Integral crystalline water proofing material mix shall be applied either as slurry coat or dry powder consistency immediately prior to placing the overlying concrete slab.

### 22.16.6 Curing

The treated surfaces should be kept damp for a period of five days and must be protected against direct sun, wind and frost, by covering with polyethylene sheeting, damp burlap or similar material.

### 22.16.7 Precaution / Special Consideration

Do not apply Integral Crystalline Slurry at temperatures at or below freezing or to frozen or freezing surfaces. Integral Crystalline slurry cannot be used as an additive to concrete or plasters. (Integral Crystalline Admixture should be considered for these applications).

### 22.16.8 Storage / Shelf Life

When properly stored in a dry place in unopened and undamaged original packaging its self life is one year.

### 22.16.9 Measurement

The Length & breadth/height of the coated area by Integral Crystalline slurry shall be measured in metre correct to two places of decimal. Measurement shall be made in sqm of the area.

### 22.16.10 Rate

The rate shall include the cost of all the labour, material and equipments involved in all the operations described above.

## 22.17 POLYMER MODIFIED FLEXIBLE CEMENTATIOUS NEGATIVE SIDE WATERPROOFING COATING WITH ELASTIC WATERPROOFING POLYMERS

### 22.17.1 Material

Flexible cementatioous negative side waterproofing coating with elastic waterproofing polymers is a one-component, concentrated liquid admixture used to enhance the performance of cementations repair mortars, plasters, stuccos, concrete mixes and toppings for restoration of horizontal, vertical and overhead concrete; concrete masonry units (CMU); and masonry surfaces.

### 22.17.2 Technical Specification/ Parameters:

1. Flexible cementations negative side waterproofing coating with elastic waterproofing polymer should have PH value of 7 and consist of liquid state.
2. This should have the density of 1.02 gm per ml.
3. This should possess the property of application in undiluted as well as diluted form.
4. This should be non-reemulsifiable.

### 22.17.3 Applications

It is to be applied using a long-haired roller, brush or spray on any horizontal, sloping or vertical surfaces to form a string, flexible, tack-free dry surface. This is easy to use and control in construction works for water proofing of the surface and optimizes bond to concrete substrates. It also improves resistance to abrasion and freeze/ thaw cycles.

### 22.17.4 Preparation of Surface

All substrates must be structurally sound, stable and solid, with all loose material removed. Thoroughly clean the surface of any substance that could interfere with the bond of the installation material, including dirt, paint, tar, asphalt, wax, oil, grease, latex compounds, from release agents, laitance, foreign substances pre existing paint film & loose particles till plaster is visible and any other residues. Concrete surfaces must be mechanically profiled and prepared by shotblasting, sandblasting, diamond-grinding, water-jetting, scarifying or other engineer-approved methods to obtain an acceptable profile. Concrete substrate and ambient room temperatures must be maintained between 45°F and 95°F (7°C and 35°C) before application. Temperatures must be maintained within this range for at least of 72 hours after the application coating. Application temperature varies from 7°C to 40°C.

### 22.17.5 Application Procedure

Apply the coating on to this sound and dry surface using a long-haired roller, brush or spray. The dilution of the compound the water should be done in a clean mixing pail. The polymer modified flexible cementitious negative side water proofing coating with elastic water proofing polymers shall be applied on interior wall plaster surface in three coats @ 14.35 kg/10 sqm or more as recommended by manufacturer specification. The ratio of mixing with water is to be done in accordance with the nomenclature of the item along with corresponding coats and manufacturer specifications. One coat i.e. first coat of self priming cementitious water proofing polymers shall be applied on to the properly prepared and dried surface (diluted with water in the ratio of 1:1). Another coat shall be applied when the coat below is still wet. Two coats of cementitious water proofing polymers (diluted with water in the ration of 3:1) over the first coat applied. All the coats shall be applied in perpendicular direction to each other. The final surface is to be protective from excessive heat or draft conditions during the first 24 to 72 hours. Final surface should be cured for at least 5 to 7 days. Use of damp burlap, polyethylene sheeting or water-based curing compound is also recommended to be used for curing.

### 22.17.6 Measurement

The length and breadth/ height shall be measured in running metre correct to two places of decimal and the area of applications shall be measured in sqm correct to two places of decimal.

### 22.17.7 Rate

The rate shall be include the cost of all the labour and material involved in all the operations described above.

## 22.18 WATER PROOFING TREATMENT WITH INTEGRAL CRYSTALLINE WATER PROOFING DRY-SHAKE

### 22.18.0 General

Crystalline water proofing dry-shake of **hydrophilic in nature** is a unique Integral Crystalline chemical treatment for the waterproofing and protection of concrete. Crystalline water proofing dry-shake has been formulated for dry-shake applications on horizontal concrete surfaces where greater impact and abrasion resistance is required.



### 22.18.1 Material

Integral Crystalline water proofing dry-shake (dry powder) compound consists of Portland cement, various active proprietary chemicals, and a synthetic aggregate hardener that has been crushed and graded to particle sizes suitable for concrete floors.

Crystalline water proofing dry-shake becomes an integral part of the concrete surface, thereby eliminating problems normally associated with coatings (e.g. scaling, dusting, flaking and delaminating). The active chemicals react with the moisture in the fresh concrete causing a catalytic reaction that generates a non-soluble crystalline formation within the pores and capillary tracts of the concrete.

#### Technical Specification/ Parameters:

The Integral Crystalline dry shake material of hydrophilic in nature shall confirm to the following requirements:

1. Dosage as specified in the nomenclature of item or higher as recommended by manufacturer's specification. The material shall fulfill the requirements of American Concrete Institute Guidelines ACI-212- 3R-10 Chapter 15 or European norms EN 934-2-T2 and fall under PRAH (Permeability reducing Admixtures for HYDROSTATIC conditions) and shall be capable of withstanding/resistant to 16 bar hydrostatic pressure and reduce Coefficient of Permeability of concrete by more than 90, when compared to controlled concrete and tested as per DIN 1048 Part 5 or EN 12390-8 by carrying out 4 cycles each of 5 bar hydrostatic pressure for 72 hours and drying for 48 hours between the cycles. The co-efficient of Permeability calculated as per Darcy's Formula/Valenta equation by incorporating penetration values obtained at the end of fourth cycle pressure.
2. It shall confirm to EN1504-3 (For structural repairs-R3, Compressive Strength > 25 MPa) supplied from an approved manufacturing unit having CE approval confirming to EN 1504-3R3.
3. The product has no corrosion effect on reinforcement steel according to test norm DIN V18998. The maximum chloride content less than 0.1%.
4. The Integral Crystalline dry shake shall be capable of self-healing of cracks up to a width of 0.5mm.
5. The integral crystalline dry shake, when used in the concrete, will have no detrimental side effects in terms of Alkali Silica Reaction (ASR), corrosion of Steel Reinforcement etc.
6. The integral crystalline dry shake performance shall not be affected by wear abrasion of the treated concrete surface and crystalline treated concrete shall not require protection layer.
7. The crystalline water proofing coating/slurry shall be non toxic and suitable for use in potable water facilities- NSF listed as per ANSI 61 listing or DVGW-W347, Germany or equivalent and a declaration of performance certificate supervised by a reputed European/US third party.
8. The manufacturer shall submit guarantee in respect of crystalline water proofing dry shake performance for 10 years against any leakage.

**Note:** The manufacturer shall submit test certificates in respect of all above specification/parameter as stated above of Integral Crystalline water proofing dry shake material from reputed National/International laboratories as per relevant codes.

Total quantity of the Integral Crystalline water proofing dry shake material required shall be arranged at site of work only after obtaining the prior approval of the Engineer-in-Charge in writing. The proper account of water proofing compound used in the work shall be maintained. It shall be ensured that the consumption of the compound is as per specified requirements. Contractor shall associate himself with anyone of the applicator of water proofing compound duly approved by the Engineer-in-Charge before start of work relating to the water proofing treatment.

### 22.18.2 Application Rate (Dose)

Crystalline water proofing dry-shake material to be used under normal conditions should cover the application surface sprinkled @ 0.60 kg per sqm or higher as recommended by the manufacturer specification over the lean concrete of structure depending upon the degree of abrasion resistance required.

If the surface is to be used under heavy traffic conditions or where greater abrasion resistance is required, the manufacturers recommendation should be taken into account while applying crystalline water proofing dry-shake on the concrete surface.

### 22.18.3 Application Procedure

- (i) After fresh concrete is placed. Consolidated and levelled, wait until concrete can be walked on leaving an indentation of 6-8mm.
- (ii) Concrete should be free of bleed water and be able to support the weight of a power trowel. Float open the surface.
- (iii) Immediately after floating open the surface and within one hour of finishing the concrete, apply one-half of the Integral Crystalline water proofing dry-shake material by hand or mechanical spreader, in one direction only. The Integral Crystalline water proofing dry-shake material must be spread evenly.
- (iv) As soon as the Integral Crystalline water proofing dry-shake material has absorbed moisture from the base slab, it should be power floated to the surface.
- (v) Immediately after power floating, apply remaining Integral Crystalline water proofing dry-shake material at right angles to the first application.
- (vi) Allow remaining Integral Crystalline water proofing dry-shake material to absorb moisture from the base slab and then power float the material into the surface. When concrete has hardened sufficiently, power trowel surface to the required finish.

### 22.18.4 Curing

Curing is important and shall begin as soon as final set has occurred but before surface starts to dry. Conventional moist curing procedures such as water spray, wet burlap or plastic covers may be used. Curing should continue for at least 48 hours. In hot dry sunny or windy conditions, it is advisable to use an evaporation retardant on the fresh concrete surface to prevent premature drying of the slab conditions due consultations should be made from the technical representatives of the manufacturer for specific instructions. In lieu or moist curing, concrete sealers and curing compounds may be used. In all cases, recommended guidelines for proper curing should be followed.

### 22.18.5 Recommended uses

|                          |  |
|--------------------------|--|
| Basement Rafts           | Foundation slab                        |
| Water tank base slab     | Sewage and Water Treatment Plants slab |
| Below Grade Structures   | Warehouses Floors                      |
| Traffic Bearing Surfaces | Parking Structures                     |

### 22.18.6 Precaution / Special Consideration

For the best results when applying Integral Crystalline dry shake materials, the air content of the concrete shall not exceed 3% (a high air content can make it difficult to achieve a proper application).

In hot, dry, or windy conditions, it is advisable to use an evaporation retardant on the fresh concrete surface to prevent premature drying of the slab.

### 22.18.7 Storage / Shelf Life

Integral Crystalline dry shake must be stored dry at a minimum temperature of 7° C and its self life is one year when stored under proper conditions.

### **22.18.8 Measurement**

The quantity of Integral Crystalline dry shake sprinkled area shall be calculated in sqm. The Length & breadth/height of the Integral Crystalline dry shake sprinkled area shall be measured in metre correct to two places of decimal.

### **22.18.9 Rate**

The rate shall include the cost of all the labour, material and equipments involved in all the operations described above.

## **22.19 CRYSTALLINE WATER PROOFING MORTAR**

### **22.19.1 Material**

Crystalline water proofing mortar consists of Portland cement, specially treated quartz sand and a compound of active chemicals.

The active chemicals react with moisture and the by-products of cement hydration to cause a catalytic reaction, which generates an insoluble integral crystalline complex. These crystalline complexes grow in the presence of water and block the capillaries of the concrete and minor shrinkage cracks, thus water proofing the concrete. Chemicals activation begins when the powder is mixed with water and may take several days to completely block the capillaries, depending on ambient temperature and environmental conditions. It can be applied to the positive or negative water pressure sides of a structure.

### **22.19.2 Technical Specification/ Parameters:**

1. The crystalline water proofing mortar shall conform to EN1504-3 having Compressive Strength Class R4  $\geq$  45 MPa and adhesive bond strength Class R3  $\geq$  1.5 MPa supplied from an approved manufacturing unit having CE approval confirming to EN 1504-3R3.
2. It has no corrosion effect on reinforcement steel according to test norm DIN V 18998. The maximum chloride content less than 0.1%.
3. The crystalline water proofing mortar, when used in the concrete, will have no detrimental side effects in terms of Alkali Silica Reaction (ASR), corrosion of Steel Reinforcement etc.
4. The crystalline water proofing mortar performance shall not be affected by wear abrasion of the treated concrete surface and crystalline treated concrete shall not require protection layer.
5. The crystalline water proofing mortar shall be non toxic and suitable for use in potable water facilities- NSF listed as per ANSI 61 listing or DVGW-W347, Germany or equivalent and a declaration of performance certificate supervised by a reputed European/US third party.
6. The manufacturer shall submit guarantee in respect of crystalline water proofing mortar performance for 10 years against any leakage.

Note: The manufacturer shall submit test certificates in respect of all above said specification/parameters of Crystalline mortar from reputed National/International laboratories as per relevant codes.

Total quantity of the water proofing Crystalline Mortar material required shall be arranged at site of work only after obtaining the prior approval of the Engineer-in-Charge in writing. The proper account of water proofing compound used in the work shall be maintained. It shall be ensured that the consumption of the compound is as per specified requirements. Contractor shall associate himself with anyone of the specialist firms mentioned in approved list of applicator of water proofing compound only approved by Engineer-in-Charge before start of work.

### 22.19.3 Recommended Uses

RCC underground structure like basement, water tanks, bridge deck etc.

This material can be applied in conjunction with crystalline water proofing coating for :

- (i) Installation of seal strips, reglets and coves at joints to assure water tightness
- (ii) Patching and filling / sealing of routed out cracks.
- (iii) Patching of tie holes and faulty construction joints.
- (iv) Repairing of spalled and honeycombed area.

### 22.19.4 Preparation of Surface

All surfaces to be patched, repaired or sealed with crystalline water proofing mortar must be clean and sound. **Crack** should be routed out to a U-shaped groove, size 25 mm wide and 25 mm deep. **Tie holes** should be roughened prior to filling. **Spalled and honeycombed area** must be thoroughly cleaned and chiseled back to sound concrete prior to repair. Remove all dirt, cement laitance, form release agents, curing compounds, paints, coating, etc. by means of wet or dry sand blasting, high pressure water jet or other approved mechanical means. Surfaces must be well moistened to a dull dampness at the time of application. The concrete should be damp with no wet sheen on the surface.

### 22.19.5 Mixing

- (i) **For routed cracks, coves and non-moving joints:** Add water to crystalline water proofing mortar powder until a medium stiff, trowelable consistency reached. The texture of the mix should be pliable enough to be trowelled into the cracks with some pressure, but not so pliable that it would run out or sag out of the crack.  
Approximate mixing ratio (by volume) is 4.5 parts crystalline water proofing mortar powder to 1 part water. Alternatively, 450gm of crystalline water proofing mortar powder to 100 ml of water is to be mixed or as specified by the manufacturer specification.
- (ii) **Tie holes and pointing applications:** Add only a small amount of water. Mixed consistency should be that of "dry earth," holding a shape when squeezed in your hand but easily crumbled when pressed between fingers. Mix only as much material as can be used within 20 minutes.

### 22.19.6 Application Procedure

- (i) **For sealing cracks and faulty construction joints,** routed out/making U-shape groove size 25x25mm and then priming the surface with integral crystalline slurry @0.05 kg per running meter and while the surface is tacky filled the groove upto surface crystalline mortar @1.50 kg per running meter. Once crystalline mortar is touch dry then finally applying two coats of integral crystalline slurry @0.05 kg per running meter per coat.
- (ii) **For repairing spalled & honeycombed areas,** prepared the surface and chiesel back upto sound concrete and then primed the area with integral crystalline slurry @0.70 kg per sqm. and while the surface is tacky repair and level the honeycomb area with crystalline mortar @ 22.70 kg per sqm. for an average thickness of 10mm. Once crystalline mortar is touch dry then finally two coats of integral crystalline slurry @ 0.70kg per sqm. per coat.
- (iii) **For patching of tie rod holes,** prepared tie rod hole surface and primed the area with integral crystalline slurry @ 0.07 kg per sqm and while the surface is tacky repair and filled the tie rod holes with crystalline mortar @ 0.040 kg per hole. The crystalline mortar shall be tightly rodded into tie rod holes or packed tightly. For 25x25x25 mm hole, use 0.040 kg per hole to fill the tie rod hole.

### **22.19.7 Curing**

Provide protection against extreme weather conditions, such as heavy rain or freezing conditions, during the setting period. Curing is not normally required except during hot, low humidity weather. In these conditions, a light mist of water approximately 25 hours after the repair is completed will help to ensure a controlled cure. In extreme dry heat, water misting may be carried out at required intervals more frequently.

### **22.19.8 Precaution / Special Consideration**

Crystalline mortar shall not applied at temperatures below 40°F (4°C), to a frozen substrate or if temperatures will drop below freezing during the curing period (approximately 24 hours). This product is not recommended for use in expansion or construction joints. Crystalline mortar can be applied in (13 mm) layers not exceeding 2.5 inch (approximately 6.5 cm) to prevent shrinkage cracks in the mortar.

### **22.19.9 Storage / Shelf Life**

Crystalline mortar shall be stored in a dry enclosed area off the ground at a minimum temperature of 7°C. Self life when stored in proper conditions in unopened, undamaged packaging is one year.

### **22.19.10 Measurement**

Faulty construction joint will be measured by measuring the length in running meter correct to two places of decimal.

Repair of honeycombed area will be measured in square meter correct to two places of decimal by measuring the length and width of treated area correct to two places of decimal.

For repair of tie rod holes, the measurement shall be done for each number of hole.

### **22.19.11 Rate**

The rate includes the cost of all the labour and material involved in all the operations described above.

## **22.20 SWELLABLE TYPE WATER STOP TAPE**

### **22.20.0 General**

Swellable type water stop tape of size 19 mm x 25 mm thick in linear metre (expansive nature) is a unique sealing compound designed to expand rapidly when exposed to moisture, making it a self-healing joint material for construction joint applications / treatment .

### **22.20.1 Material**

This is a swellable type sealing compound which expand rapidly after coming in to contact or exposed to moisture. This acts as a self healing material and is used for applications in construction joints.

### **22.20.2 Physical Properties**

- (i) Specific gravity (ASTM D71):  $1.35 \pm 0.05$  (ASTM D-71)
- (ii) Volatile matter: 1% maximum (ASTM D-6)
- (iii) Penetration, 150g cone at 25°C, 5sec :  $40 \pm 5$ mm (ASTM D-217)
- (iv) Rate of Rapid Expansion:
  - (a) Fresh Water Exposure: 24 Hours-140%, 48 Hours- 175%, 72 Hours-190% & 120 Hours-210%.
  - (b) Salt Water Exposure: 24 Hours-7%, 48 Hours-12%, 72 Hours-14%, 120 Hours-18%

The water stop material should meet the requirements to EU REACH Regulation (EC) No 1907/2006.

### 22.20.3 Physical Properties of Swellable Water stop Primer

- (i) % Solid : Min 20%
- (ii) Flash Point: 93 deg C
- (iii) Dry Time : 25 deg C:10 min
- (iv) Dry Time : 4 deg C : 60 min

### 22.20.4 Recommended Uses

Typical applications for swellable type water stop tape include building foundations, raft slabs, retaining walls, water storage tanks, at the junction of raft slab with the retaining walls and similar non-moving cold construction joints etc.

### 22.20.5 Application

- (i) The entire surface length where the water stop is to be applied is cleaned thoroughly by using blower and brush. Apply one coat of required primer throughout the length of the joint @ 3.78 litre per 240 running metre. Allow the primer to dry for 10 to 15 minutes at the temperature of 25°C. This should be allowed to dry for some longer time in the areas where the temperature are low.
- (ii) By using the heel of the hand and moderate pressure, press the self expanding joint material firmly into the position on the structure on the entire area which has been primed and dried. Make sure that the product has bonded with the primed area.
- (iii) Where required, splice ends to form a continuous, uninterrupted seal. For best results, cut each end at opposite 45deg. angles and tightly butt ends together. DO NOT OVERLAP ENDS. Gently knead the spliced ends creating an uninterrupted seal.
- (iv) Peel the protective covering from the exposed side of the installed expandable joints sealing compound.
- (v) Pour the matting structural member in position.

#### Notes:

The manufacturer shall submit guarantee in respect of swellable type water stop tape performance for 10 years against any leakage.

Always use swellable type water stop primer to avoid displacement of the swellable type water stop tape during concrete pouring. It may be necessary to utilize masonry nails or other mechanical means to hold the sealant in place on vertical surfaces.

Place swellable type water stop tape so that it is not closer than 5 cm away from the outer surface of poured structure. If a Key way is utilized, place the swellable type water stop tape into the bottom of the formed Keyway area.

### 22.20.5 Precaution / Special Consideration

Always use swellable type water stop primer to ensure tight adhesion and to aid in preventing swellable type water stop tape from moving during the concrete pour. For vertical surfaces, nails may be used to hold the product in place in conjunction with swellable type water stop primer. Swellable type water stop tape shall be used at a minimum depth of 50 mm inside the concrete. When used on pipes and other structural penetrations, swellable type water stop tape shall be cut to measured length and placed around the penetration with ends butted. In all cases, swellable type water stop tape shall be in direct contact with the substrate along the entire length of the installation. Swellable type water stop tape is not an expansion joint sealant and only suitable for non-moving concrete joints. Swellable type water stop tape should not be installed in standing water or on frozen or icy surfaces

**22.20.6 Storage / Shelf Life**

When stored in a dry enclosed area off the ground at a minimum temperature of 45°F (7°C) in unopened, undamaged cartons, its self life is unlimited.

**22.20.7 Measurement**

The measurement shall be taken by measuring the length of swellable type water stop tape in meter correct to two places of decimal.

**22.20.6 Rate**

The rate shall include the cost of all labour and materials involved in all the operations described above.

**BITUMEN FELTS (FIBRE HESSIAN BASE)**  
(Clause 22.8.1.1)

**A-1 Weights**

The weights of the ingredients used in the manufacture of bitumen felts per 10 sqm shall be not less than those specified in Table A-I

**TABLE A-I**  
**Minimum Weights of Bitumen Felts**

| S. No. | Type of felt                | For 10 sqm     |          |         |                 |  |
|--------|-----------------------------|----------------|----------|---------|-----------------|--|
|        |                             | Untreated Base | Saturant | Coatant | Bitumen content | Total weight of the finished bitumen felt in dry condition with mica dusting powder Min. |
|        |                             | Kg             | Kg       | Kg      | Kg              | Kg   |
|        | Fibre Base                  |                |          |         |                 |  |
| (i)    | Type 2 grade 1 Hessian Base | 5.0            | 4.5      | 12.9    | 12              | 22.6   |
| (ii)   | Type 3 Grade 1              | 2.3            | 1.8      | 17.7    | 12.1            | 23   |
| (iii)  | Type 3 Grade 2              | 2.3            | 1.8      | 31.8    | 20.2            | 37.1   |

**Notes:**

1. The weight of the untreated base shall be taken as in the dry condition.
2. Includes allowance for 1.2 kg minimum mica dusting powder in dry condition.

**A-2 Testing**

**A-2.1** Frequency of test shall be decided by the Engineer -in-charge depending on quantum of work. From each of the rolls one piece 3 m long and the full width of the felt shall be cut out for preparing test specimens. The first 2M. of the roll shall not be selected for this purpose. The lengths of felt so selected shall be free from abnormal defects and shall be truly representative of the whole consignment. The selected pieces of felt shall be dispatched without breakage or distortion, wrapped up in water proof paper or other similar materials so as to cause no damage to the material during transit. In case the material has stuck together, no heat shall be applied to separate the layer but the whole roll shall be sent for testing and the fact shall be reported.

The samples, when tested as per IS1322 shall conform to the requirements given in Table A-II.



**TABLE A-II**

| <b>Sl. No</b> | <b>Type of Felt</b> | <b>Breakin g strengt h kg</b> | <b>Pliability Test</b>   | <b>Storage sticking tests</b>  | <b>Heat Resistance Test</b>  | <b>Pressure head test</b>                              | <b>Water absorp tion test Max.</b> |
|---------------|---------------------|-------------------------------|--|--|--|--|------------------------------------|
| 1             | Type 2 (all grades) | 95 / 60                       | (i) The roll shall not show cracks on unrolling<br><br>(ii) Consider any surface rupture exceeding 5 mm in length as failure | The test pieces shall be examined after cooling<br><br>After release of the load, the layers of felt shall be capable of being separated without damaging the coatant in any way | The test pieces shall show no sign of melting of the bitumen compound<br><br>- | The test pieces shall show no sign of leakage<br><br>- | 5.0%<br><br>-                      |
| 2             | Type 3 (all grades) | 135/90                        | (i) The roll shall not show cracks on unrolling<br><br>(ii) Consider any surface rupture exceeding 5 mm in length as failure | The test pieces shall be examined after cooling<br><br>After release of the load, the layer of felt shall be capable of being separated without damaging the coatant in any way  | The test pieces shall show no sign of melting of the bitumen compound<br><br>- | The test pieces shall show no sign of leakage<br><br>- | 2.0%<br><br>-                      |

**GLASS FIBRE BASE BITUMEN FELT**  
(Clause 22.8.1.1)

**B-1 Weight**

The weight of the ingredients used in the manufacture of glass fibre felts for 10 square metre shall be not less than those specified in Table B-I.

**TABLE B-I**  
**Minimum Weight of Bitumen Glass Fibre Base Felt**

For 10 Square Metre

| S. No. | Type of Felt | Untreated Base | Treated Base | Coatant | Total weight in dry condition including surfacing materials |
|--------|--------------|----------------|--------------|---------|---|
|        |              | (kg)           | (kg)         | (kg)    | (kg)  |
| 1      | Type 2 Gr. I | --             | 0.4          | 15.3    | 18.0  |

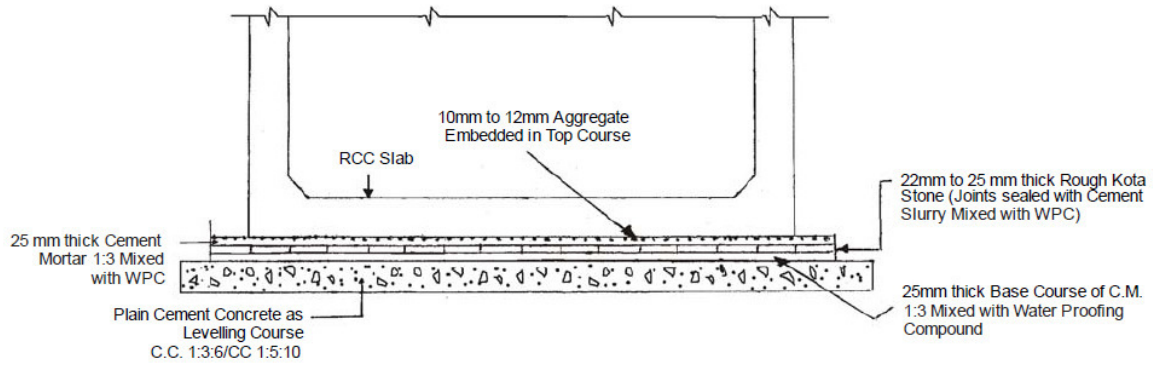
**B-2 Tests**

The sample, when tested as per IS 7193 shall conform to the requirements given in Table B-II

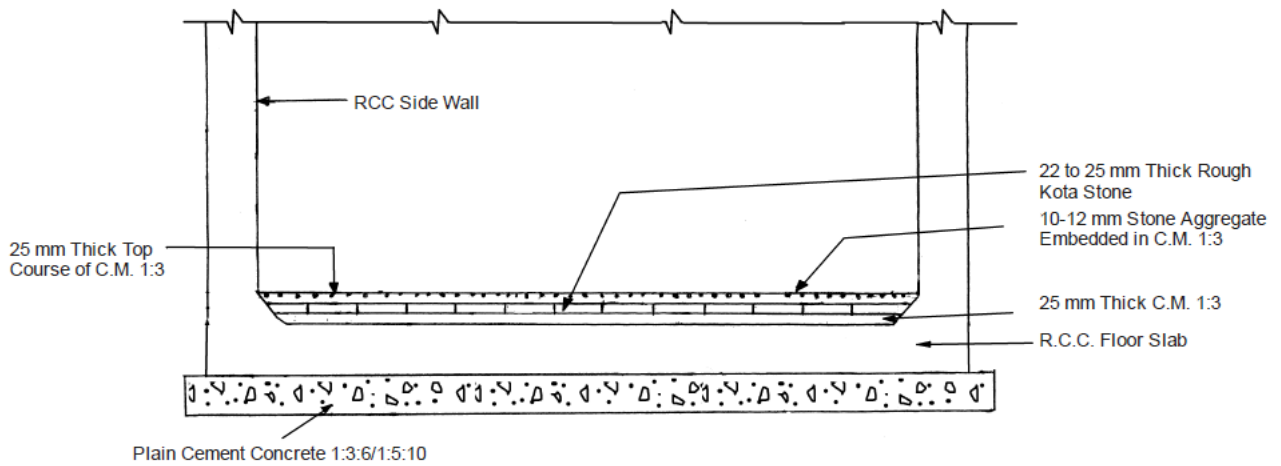
**TABLE B-II**  
**Requirements of Glass Fibre Felts**

| S. No. | Properties                | Requirements   |
|--------|---------------------------|--|
| (i)    | Breaking strength, Min kg | (a) Warp 50<br>(b) Weft 30   |
| (ii)   | Pliability test           | (a) Roll shall not show cracks on unrolling<br>(b) Consider any surface rupture exceeding 5 mm in length as failure.                       |
| (iii)  | Storage sticking          | The test pieces shall be examined after cooling. After release of load, the layers of felt be capable of being separated without damaging. |
| (iv)   | Pressure head             | The test pieces shall show no sign of leakage.   |
| (v)    | Heat resistance           | The test pieces shall show no sign of melting of bitumen compound.   |
| (vi)   | Water absorption          | 2 per cent   |

**Sub Head : Water Proofing Treatment  
Clause : 22.1**

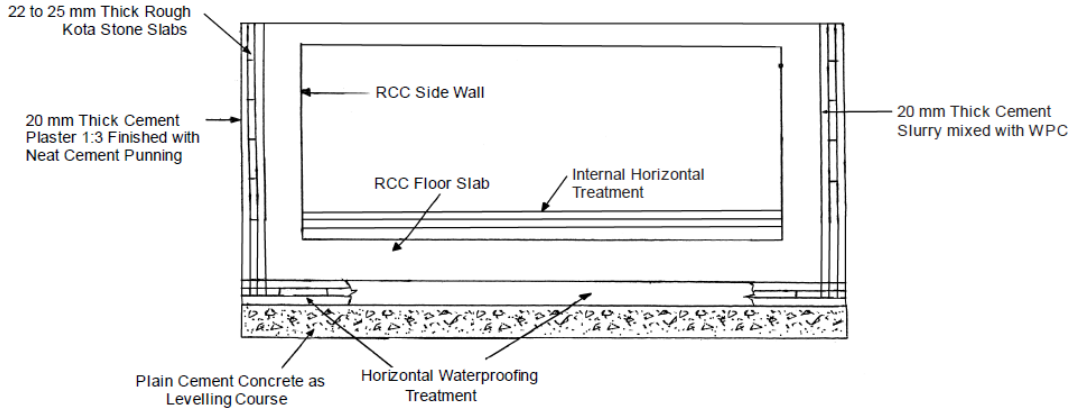


**Fig. 22.1 : Waterproofing of Horizontal Surface of U.G. Structure**



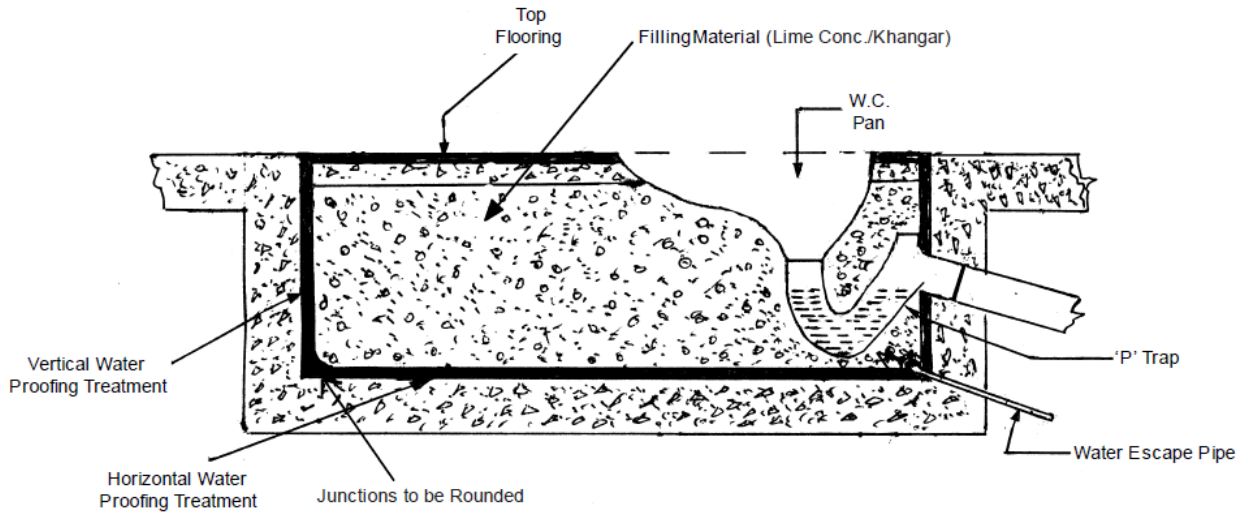
**Fig. 22.2 : Water Proofing Horizontal Surfaces from Inside of a U.G. Structure**

**Sub Head : Water Proofing Treatment  
Clause : 22.2**



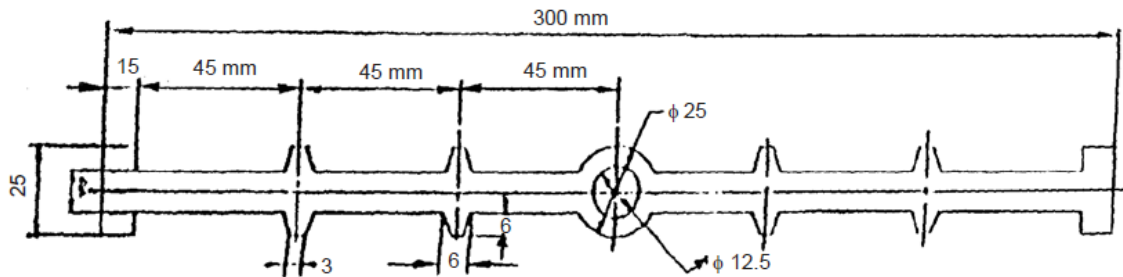
**Fig. 22.3 : Waterproofing on Vertical Surfaces of Under Ground Structures**

**Sub Head : Water Proofing Treatment  
Clause : 22.3**



**Fig. 22.4 : Position of Horizontal and Vertical Waterproofing Treatment in Sunken Portion of W.C./Kitchen and the like**

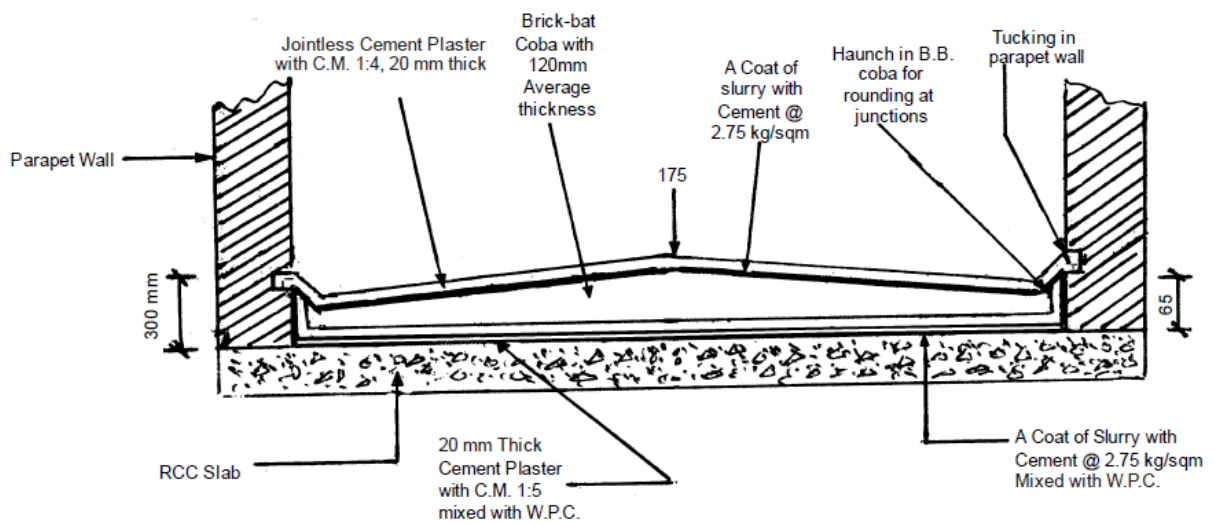
**Sub Head : Water Proofing Treatment  
Clause : 22.4**



All dimensions in millimeters

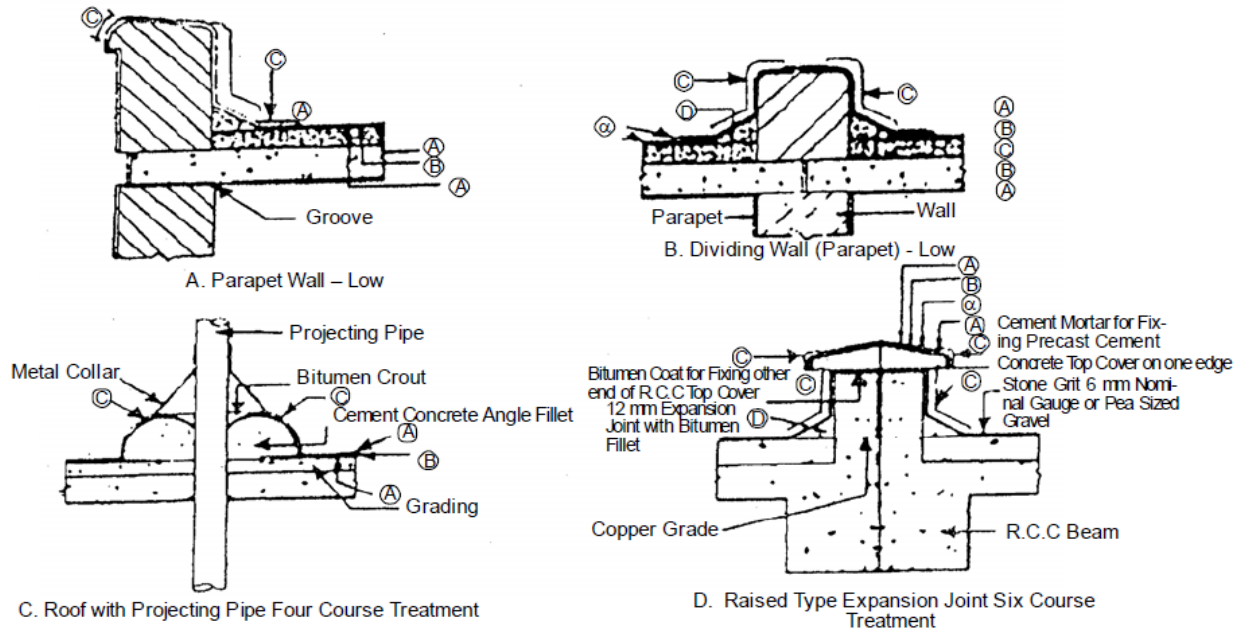
**Fig. 22.5 : Typical Cross-Section of PVC Water-Stop**

**Sub Head : Water Proofing Treatment  
Clause : 22.7**



**Fig. 22.6 : Integral Cement based Waterproofing Treatment with Brick-bat Coba Over a RCC Slab**

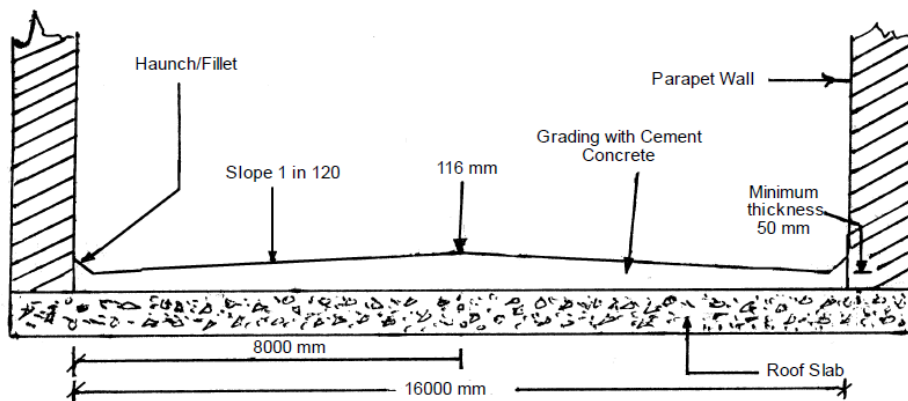
**Sub Head : Water Proofing Treatment  
Clause : 22.8**



Diagrams Not to Scale  
All dimensions are in mm

**Fig. 22.7 : Water Proofing**

**Sub Head : Water Proofing Treatment  
Clause : 22.9**



**Fig. 22.8 : Grading Roof Slab with Cement Concrete**

Sub Head : Water Proofing Treatment  
Clause : 22.10

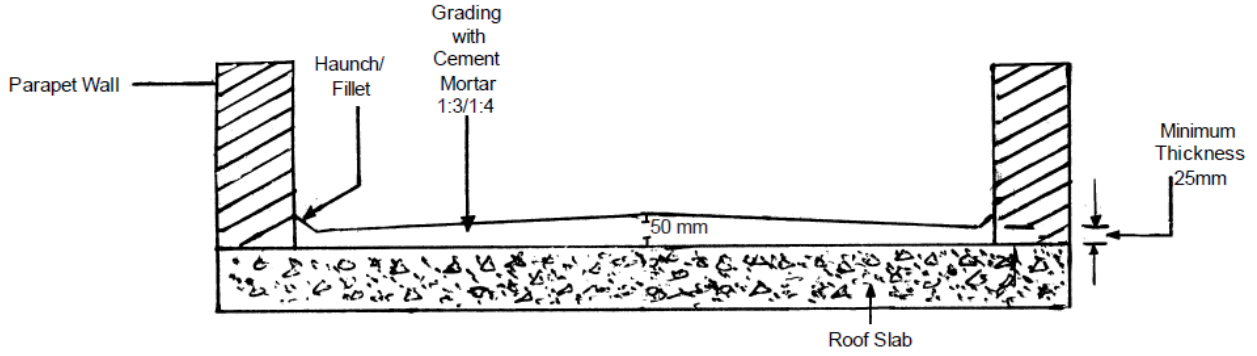


Fig. 22.9 : Grading Roof Slab with Cement Mortar 1:3/1:4

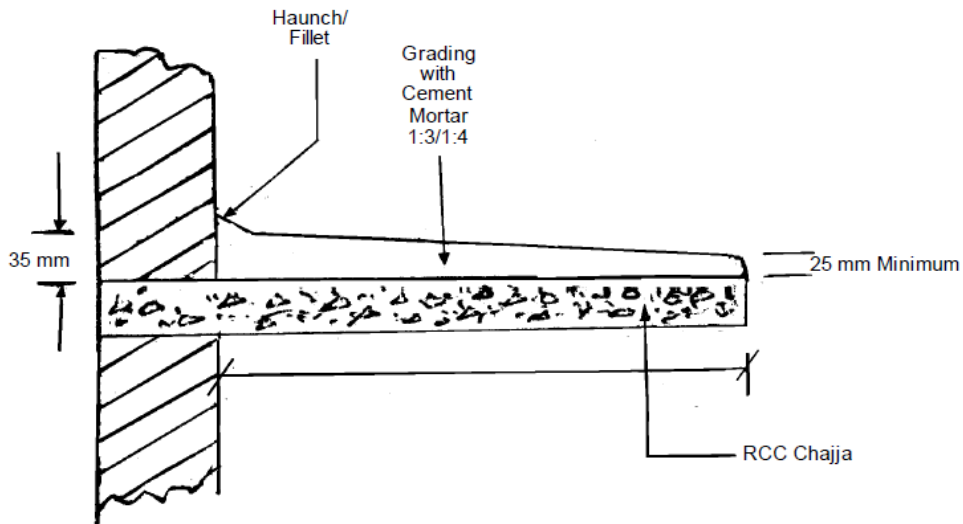


Fig. 22.10 : Grading Chajja with Cement Mortar 1:3/1:4

**SUB HEAD : 23.0**

**RAIN WATER HARVESTING &  
TUBEWELLS**





## CONTENTS

| <i>Clause No.</i> | <i>Brief Description</i>                                 | <i>Page No.</i> |
|-------------------|--|-----------------|
|                   | List of Bureau of Indian Standards (BIS) Codes           | 1211            |
| 23.0              | Terminology  | 1212            |
| 23.1              | General Requirements                                     | 1220            |
| 23.2              | Type of Tubewells  | 1221            |
| 23.3              | Drilling Methods   | 1221            |
| 23.4              | Accessories to be used in Tubewell Construction          | 1022            |
| 23.5              | Information to be furnished by the owner of the Tubewell | 1222            |
| 23.6              | Information to be furnished by Drilling Agency           | 1223            |
| 23.7              | Design and Lowering of Pipe Assembly                     | 1224            |
| 23.8              | Gravel Packing   | 1224            |
| 23.9              | Development of Tube well                                 | 1225            |
| 23.10             | Disinfection   | 1230            |
| 23.11             | Grouting and sealing                                     | 1231            |
| 23.12             | Handing over of the Tube well                            | 1231            |
| Appendix-I        | Annexure-A   | 1232            |
| Fig. 23.1         | Cavity well (for Centrifugal Pump)                       | 1233            |
| Fig. 23.2         | Cavity well (for Turbine Submersible Pump)               | 1233            |
| Fig. 23.3         | Tubewell (Natural Gravel Pack)                           | 1233            |
| Fig. 23.4         | Tubewell (Artificial Gravel Pack)                        | 1233            |
| Fig. 23.5         | Tubewell (Artesial flowing)                              | 1234            |
| Fig. 23.6         | Borewell in Hard Rock                                    | 1234            |
| Fig. 23.7         | Hand Auger   | 1235            |

|            |   |      |
|------------|---|------|
| Fig. 23.8  | Spiral Auger or Ram's Horn  | 1235 |
| Fig. 23.9  | Simple Jetting Rig  | 1236 |
| Fig. 23.10 | Typical details of Taper reducers, well cap, V-notch Plate, Centralizing Guide, Bail Plug and Clamp | 1237 |
| Fig. 23.11 | Closed Well Development With Air Compressor   | 1238 |
| Fig. 23.12 | Open Well Development With Air Compressor   | 1239 |
| Fig. 23.13 | Surge Block   | 1240 |

### LIST OF BUREAU OF INDIAN STANDARDS (BIS) CODES

| <i>S. No.</i> | <i>BIS. No.</i>      | <i>Subject</i>   |
|---------------|----------------------|--|
| 1.            | IS 226:1975          | Structural Steel   |
| 2.            | IS 460:1985 (Part-1) | Code of practice for particle size distribution  |
| 3.            | 1239 (Part I):1990   | Mild steel tubes, tubulars and other wrought steel fittings:<br>Part I Mild steel tubes (fifth revision)                         |
| 4.            | 2800 (Part I): 1991  | Code of Practice for Construction and Testing of Tubewells/<br>Borewells   |
| 5.            | 3589 :1991           | Seamless or electrically welded steel pipes for water, gas<br>and sewage (1683 to 2032 mm outside diameter) (second<br>revision) |
| 6.            | 4097: 1967           | Gravel for use as pack in tubewells  |
| 7.            | 4270 : 2001          | Steel tubes used for water wells(second revisions)   |
| 8.            | 8110 : 1985          | Well Screens and Slotted Pipes   |
| 9.            | 9439 : 1980          | Glossary of terms used in water-well drilling technology   |
| 10.           | 10500 : 1983         | Drinking water   |
| 11.           | 10151 : 1982         | Polyvinyl chloride (PVC) and its copolymers for its safe use<br>in contact with foodstuffs, pharmaceuticals and drinking water   |
| 12.           | 11189 : 1985         | Methods for tubewell development   |
| 13.           | 12818 : 2010         | Unplasticized PVC ribbed screen casing and plain casing<br>pipes for bore/ tubewells - Specification                             |

## 23.0 RAIN WATER HARVESTING & TUBE WELLS

### 23.0 TERMINOLOGY

**Acidizing:** The process of introducing acid into the pore spaces of acid soluble formations to enlarge the pore space by dissolving the surrounding formation. Acidizing also refers to the removal of encrustation from well screens and gravel pack, and dissolving cementations materials.

**Additive:** An auxiliary agent added for conditioning of drilling fluid to obtain desired physical properties.

**Air Drilling:** The drilling process in which air or gas is used as a medium for removal of cuttings.

**Air Line:** The small diameter vertical pipe inserted in the tube wells with or without the ejector for cleaning and developing tube wells by airlift method.

**Air Line Lubricator (In-Line Oiler):** An apparatus that feeds a small controllable quantity of lubricating oil into the air stream to provide lubrication for pneumatic components/accessories of machines.

**Air Rotary Drilling:** A process similar to direct circulation rotary drilling except that compressed air is used as a drilling fluid instead of drilling mud.

**Annular Space:** The space between drill pipe and wall of the hole, or Casing and wall of the hole, or Drill pipe and casing.

**Annular Velocity:** The up-hole return velocity of fluid or air in the annulus, usually expressed in m/min.

**Antifoam:** An agent added to acid to prevent or retard foaming during the acid reaction.

**API (American Petroleum Institute):** The designation given to equipment or parts of equipment standardized by the American Petroleum Institute, such as drill pipe threads.

**Aquifer:** An aquifer is a geological formation, group of formations, or part of a formation that contains sufficient saturated permeable material to yield significant quantities of water to wells and springs.

**Artesian:** Artesian is synonymous with confined artesian water and artesian water bodies are equivalent respectively to confined ground water and confined water body. An artesian well is a well deriving its water from an artesian or confined water body. The water level in an artesian well stands above the top of the artesian water body it taps.

**Artesian Well:** A Well tapping confined or artesian aquifer in which the static water level stands above the water table, in which case those wells with water level above the water table are said to have positive artesian head (pressure) and those with water level below the water table, negative artesian head.

**Bailer:** A tube fitted with a valve at its base, which is lowered into a bore hole to remove cuttings and water.

**Barrel:** Unit of measurement consisting of 42 US gallons.

**Barite:** Barium sulphate, the commercial product contains small amounts of iron oxide, silica, and other minerals. It is used to make mud heavier.

**Barytes:** Natural barium sulphates, used as a basic material for weighing agents.

**Bentonite:** A finely powdered, highly plastic, colloidal material used in preparing drilling mud.

**Bit:** The cutting element attached to the bottom of the drill stem. Can be of various types - for example, Rock roller, Drag, Diamond, Tungsten carbide tipped, etc.

**Bit Breaker:** A heavy plate, which fits in the rotary table and holds the bit while it is being unscrewed from the drill stem.

**Bit Nozzle:** A fluid port in the bit.

**Blocks, Crown and Travelling:** An assembly of a pulley(s) mounted to rotate on an axis, with a hook or eye for anchoring or attaching to load. Pulley(s) are grooved for the wire rope. It is used to raise or lower the drill string.

**Blowout:** A sudden escape of violent escape of gas, oil or water from a drilling well when high pressures are encountered and efforts to prevent or control the escape are unsuccessful.

**Bore Hole:** Any hole bored/drilled in the ground for prospecting of oil, minerals or ground water.

**Blowout Preventor:** A device attached immediately above the casing to control pressures and prevent escape of fluids from the annular space between the drill pipe and casing or to shut off the hole if no drill pipe is in the hole, should a kick or blowout occur.

**Breakout:** The act or process of unscrewing a threaded joint - especially in case of drill pipes while it is being withdrawn from the well bore.

**Bridge:** An obstruction to circulation between the annular space of the well. A bridge is usually formed by caving of the wall of the well bore or by the intrusion of a large boulder

**Cable Tool Percussion Drilling:** A spudding process in which drilling is carried out by lifting and dropping a heavy string of drilling tools at regular intervals, resulting in crushing or loosening rock formations. The reciprocating action of the tools mixes the crushed or loosened particles with water to form a slurry or sludge. Necessary water is put into the borehole if no water is present in the formation being penetrated. The slurry is removed at intervals from the borehole by means of a sand pump or a bailer.

**Casing Pipe:** Piping used to support the sides of borehole.

**Casing Shoe:** A heavy-walled steel coupling or band at the lower extremity of the casing. It clears the way for casing.

**Cathead:** An auxiliary hoisting device used for handling light loads and for alternately lifting and dropping tools such as drive block or bumper. Its use requires a line of manila/wire rope carried on a separate sheave at the top of the derrick. It is also used for making and breaking the joints.

**Catline:** A hoisting or pulling line used in conjunction with the cathead to lift heavy equipment or tools.

**Catwalk:** A ramp on the side of the drilling rig, fitted to the derrick floor, where the pipes are laid using the catline.

**Cementing:** The process of placing the cement slurry to provide a seal against subsurface water.

**Cement Plug:** The hardened cement slurry left in the lower portion of the casing and later drilled out after the cement has set.

**Cement Slurry:** A pumpable mixture of cement and water.

**Circulate (Normal):** To pump drilling fluid from the pit, through the drill pipe and back to the surface through the annulus. The term generally applies to the operation carried out when drilling is temporarily suspended, to obtain samples from the bottom or to keep the hole in condition while awaiting other operations.

**Circulation, Direct (Drilling):** The drilling fluid movement from the mud pit to the annular space in the hole, drill pipe, kelly water swivel, suction hose, centrifugal or jet pump, settling pit and back to mud pit.

**Co-efficient of permeability:** is the velocity of flow through a permeable material at hydraulic gradient unity.

**Collapse Strength:** It is the strength of screen to withstand surrounding hydrostatic pressure on outside surface.

**Control Console:** A horizontal or vertical panel on which the entire operator's controls are located.

**Coring:** The act of procuring a sample of the formation being drilled for geological investigation. Coring is done using a core barrel.

**Crown Block:** An assembly of wire line sheaves mounted on the uppermost portion of the derrick/mast.

**Cuttings:** Particles of formations obtained from the well during drilling operations. These can be brought to the surface by the circulating fluid or air in rotary drilling or bailed out in case of cable tool drilling.

**Deadline:** Refers to the end of the drilling line, which is not related on the run. This end is usually anchored to the mast substructure and does not move as the block moves up or down during various operations.

**Die Overshot:** A long tapered die of heat-treated steel designed to fit over the top of the lost drill pipe and cuts thread when rotated. The tool is fluted to permit the escape of metal cuttings and fluids.

**Dilution:** The use of more water in the cement slurry than is necessary to produce pumpable slurry.

**Direct Circulation Rotary Drilling:** This process consists of drilling a borehole by means of a rotating bit and removing the cuttings by continuous circulation of drilling fluid as the bit penetrates the formation materials. The drilling fluid flows from the mud pit, through the pump, stand pipe, hose, drill pipe, annular space in the hole, and settling pit, back to the mud pit.

**Directional Drilling:** An operation in which a hole is purposely deviated in a controlled direction and angle.

**Down-the-Hole Drilling:** A method of drilling using down-the-hole hammers.

**Down-the-Hole Hammer:** A percussive air operated tool attached to the end of the drill string used in down-the-hole drilling. Tungsten carbide tipped bits are normally used with down-the-hole hammers.

**Drag Bit:** A rotary bit, which has two or more cutting blades, or wings with hard faced cutting edges.

**Drawdown:** Lowering of water level caused by pumping. It is a measure for a given quantity of water pumped during a specified period, or after the pumping level has stabilized.

**Draw-Works:** A power-driven winch or winches, usually equipped with clutch and brake for hoisting or lowering a drilling string.

**Drill Bit:** Drilling tool deployed in drilling operations and attached at the end of the drill string.

**Drill Collar:** A heavy drill pipe used immediately above the drill bits to put weight on the drill bit and minimize deviation of the hole.

**Driller:** A person who operates the drilling machines or rigs.

**Drill Pipe:** Special pipe, with threaded tool joints at both ends, used to transmit rotation from the rotating mechanism, thrust and weight to the bit and convey fluid, which removes cuttings from the hole and cools the bit.

**Drill String:** Components including subs, adaptors, drill pipe, drill collar, bit etc, joined together to form a drill string depending upon the type of rig used for drilling the hole.

**Drive Bushing:** Device used to transmit torque from the rotary table /drill head to the Kelly but allow vertical movement of the Kelly while drilling.

**Drive Head:** A sub fastened to the top of pipe or casing to take the blow of drive weight.

**Drive Pipe:** A pipe or casing driven through over-burden.

**Drive Weight:** Normally used in percussion drilling to give blows on top of casing to drive it. Also called drive hammer or drive block.

**Dry Hole or Duster:** A well drilled. which produces neither oil nor gas nor water of significant quantity.

**Dust Collector:** Used to control the dust and/or collect the cuttings which are discharged from the hole being drilled by air drilling.

**Dust Diverter:** Collar and hose used to divert dust and cuttings away from the operator and the machinery.

**Elevators:** Devices which latch around the drill pipe/casings attached by links to the travelling block that raises or lowers the pipe/casing from the hole.

**End Rings:** These are rings or couplers welded at both ends of screen to facilitate joining with other pipes.

**Expansion Reamer:** A device or tool having cutters that can be expanded or contracted by hydraulic or mechanical means and used to enlarge or ream bore hole below the casing or drive pipe. Also known as adjustable or under reamer.

**Feed:** The process of applying required pressure on the cutting tool to achieve the downward movement.



**Fish:** Debris in the hole such as broken bits, drill pipe, casing tools, etc, which may have broken off and lodged in the hole.

**Fishing:** The act of attempting to recover a fish.

**Fishing Magnet:** A special powerful magnet attached to a rope or drill string to fish out magnetic material.

**Fishing Tap:** A tap of heat-treated steel designed to fit to the top of the lost drill pipe and cuts thread when rotated. The tap is fluted to permit the escape of the metal cuttings and fluids.

**Fishing Tools:** Special tools used to retrieve fish from the hole.

**Fluid, Drilling:** The medium, liquid or gas used for flushing cuttings from the hole being drilled for cooling the bit and for lubricating the bit.

**Foam Flushing:** A liquid chemical added to the flushing water to stabilize the hole walls and to remove the drill cuttings effectively.

**Gel Strength:** A measure of the effect of the forces between the particles while the mud is at rest.

**Hoisting Line:** Wire rope used on the draw-works to hoist and lower the drill string.

**Hole:** Usually refers to the well bore.

**Hook Load:** The load, which may be applied to the hook, attached to the travelling block on a drill rig.

**Hydraulics:** That branch of engineering that deals with liquids in motion. It is the know-how about the effects of fluid velocities and pressures and the power involved.

**Hydraulic Percussion Drilling:** This is also known as hollow-rod drilling method. It employs a chisel shaped bit. A ball check valve is provided between the bit and lower end of the drill pipe string. Drilling is done by lifting and dropping the drill rods/ bit with quick short strokes. The drilling fluid is supplied at the surface in the annular space. It enters the ball check valve during downward stroke of drill pipe. When the bit is picked up, the ball check valve closes and traps the fluid inside the drill pipe. Continuous reciprocating motion produces a pumping action to lift the fluid to the top of the string of drill pipe where it discharges into a settling tank.

**Idler:** In machinery an idler pulley or sprocket is used in connection with belt drive and chain drive respectively to maintain desired tension in the belt or chain.

**Impression Block:** This block has many forms and designs and often used to obtain an impression of the top of the fish before attempting fishing operations.

**Jet:** A directed, rapid flow of fluid from a nozzle.

**Jet Percussion Drilling:** In this method, a chisel-shaped bit is attached to the lower end of string of pipe. Holes on each side of the blades of the bit serve as nozzles that help in loosening the material being drilled and keep the bit clean. The drill rods are rotated by hand to make the drill cut a round hole. The drilling fluid flows from the mud pit through the pump, stand pipe, hose, drill pipe and comes out through nozzles in the bit. It then flows through the annular space to settling pit and back to mud pit. With fluid circulation maintained, the drill rods are lifted and dropped in a manner similar to cable tool drilling but with shorter strokes. The bore hole is thus drilled by chopping action of the bit combined with washing action of water jets.

**Kelly:** A formed or machined section of hollow drill steel which is joined directly to the swivel at the top and to the drill pipe below. The flats or flutes of the Kelly engage the rotary table so that the rotation of the rotary table is transmitted to the kelly, which, in turn, transmits it to the drill pipe and consequently to the rotary bit.

**Laminar Flow:** Movement of fluid particles in essentially parallel paths.

**Loss of Circulation:** The loss of drilling fluid into formation pores or crevices.

**Making a Joint/Connection:** The act of screwing a joint of the drill pipe on to the drill stem suspended above the well bore.

**Making Hole:** Drilling ahead.

**Mast:** A structure on the rig used to support the crown block, top drive, pull down chains, hoisting lines, etc. It is also called Derrick or Tower.

**Marsh Funnel:** A calibrated funnel commonly used in field tests to determine the viscosity of drilling mud.

**Master Bushing:** Adaptor used to reduce the size of the rotary table opening to accommodate various sizes of bushings, slips, etc.

**Mud Balance:** An instrument consisting of a cup and a graduated arm with a sliding weight and resting on a fulcrum used to measure weight of the mud.

**Mud Gun:** A pipe that shoots a jet of drilling mud under high pressure into the mud pit to mix the additives and to stir the mud for other reasons.

**Mud Mixing:** Preparation of drilling fluid from a mixture of water or other fluids and one or more of various dry mud making materials such as clay, weighing materials, chemicals, etc.

**Mud (Slush) Pump:** A large single acting triplex or double acting duplex pump used to circulate mud down the drill pipe and up the annulus, under normal operations.

**Nozzle:** A small spout to direct the flow of fluid efficiently.

**Penetration, Rate of:** The rate at which the bit proceeds in the deepening of the well bore.

**Penetration:** It is the amount of penetration between profile wire and support rod after fusion welding.

**Percentage Open Area:** It is the open area available for entry of water as percentage of total outside surface area of pipe.

**Permeability:** Permeability or hydraulic conductivity of a medium is indicative of the ease with which water can flow through it. It depends on the properties of the medium affecting flow including porosity, packing, shape, and grain size distribution.

**Pipe Handling Equipment:** The equipment for storing, adding and removing lengths of drill pipe.

**Power- Take-Off:** The means of transmitting power from the engine of the power package, or a truck or tractor, to the other components of a drilling rig. This is usually accomplished by a separate shifting arrangement in the transmission.

**Profile Wire:** Shaped wire which is spirally wound.

**Pull Down:** Thrust or weight applied to the bit through the drill string, and the mechanism, which provides either, the hoisting or pulling power.

**Push Strength:** It is the maximum separating force that weld joint between profile wire and support rod can withstand.

**Ratio of Submergence:** This is the ratio between the length of the airline under water to the total length of airline.

**Reamer:** Cutting tool used to enlarge a bore hole.

**Reaming:** The operation of smoothening the well bore, enlarging the hole to the desired size.

**Reverse Circulation Rotary Drilling:** In this drilling process, a string of drill pipes with a drill bit at the bottom is rotated by mechanical means. Plain water or a fluid of gelling quality is circulated to prevent the hole from caving in and for sucking up the drill cuttings through drill pipes. The flow of drilling fluid takes place from the mud pit to the annular space then through the opening in the bit to the drill pipe, a centrifugal pump or jet ejector, settling pit and back to mud pit.

**Rig:** A drilling machine used for drilling a borehole.

**Rotary Drive:** Use of a power shaft to transmit driving power to the rotating element.

**Rotary Hose:** The air or mud hose that leads from the stand pipe to the swivel. also known as the 'fluid (air) or swivel hose.

**Rotary Table, Power Swivel, and/or the Rotation Drive:** The means of transmitting rotation to the drill string and bit.

**Safety Hook:** A hoisting hook with a spring-loaded latch that prevents the load from accidentally slipping off the hook.

**Sand Content:** The percentage bulk volume of sand in a drilling fluid,

**Shale Shaker:** A vibrating screen that removes coarser cuttings from the circulating fluid before it flows into the return pit.

**Sheaves:** Disc type or wheel type parts of the travelling blocks or crown block with the circumference grooved for a selected diameter of drilling lines, These can be mounted on bushings' or bearings.

**Slips:** Wedge or wedges used to prevent the drill pipe or casing pipe from slipping through the opening in the rotary table when the bit is off the bottom during trip or when adding or taking off a section of drill pipe. These may be hand or power-actuated.

**Slotted Pipes:** Slotted pipes are pipes with slots cut into them in a pattern suitable to the basic material of the pipe.

**Slot Opening:** It is the width of opening for entry of water.

**Slurry:** A mixture of cement and water that is pumped into the well to cement casing.

**Slush (Mud) Pit:** Pit used for mixing the drilling fluids and to act as a storage/settling tank for the return cuttings.

**Specific Capacity:** The ratio of the discharge to the drawdown it produces measured under the well (l/min/m of drawdown).

**Stabilizer:** Fixed to the drill string to provide stability to the drill string - can be spaced out over the entire length of the string.

**Stand Pipe:** A vertical pipe or hose carrying either air or mud to approximately the middle of the mast where it is connected to the mud, rotary or swivel hose.

**Sub:** A substitute, or adaptor, which is used to connect from one type or size of threaded connection to another.

**Support Rods:** The longitudinal shaped/circular rods supporting the profile wire.

**Swivel:** The mechanism, which permits the passage of mud or air from a stationary hose into a rotating member, such as the kelly or drill pipe.

**Tensile Strength:** It is the strength of the screen to withstand tensile load.

**Thinner:** A substance that reduces the apparent viscosity and get development of mud without lowering the density. The addition of thinner affects the colloidal clay fraction of mud.

**Thread Protector:** A coupling type device which is screwed onto or into both ends of a pipe to protect the threads from damage during transportation, storage or moving around the drill site.

**Tongs:** The tools used in making or breaking a joint of pipe during a drilling operation. Their action is much the same as that of a pipe wrench.

**Tool Joint:** Threaded portions of the drill string, which may be either box or pin type.

**Tower:** See Mast.

**Transfer Case:** A transmission to distribute power from the engine to other rig components.

**Tube well efficiency:** The formation loss (head loss) required to produce flow divided by the total drawdown observed in the well.

**Wall Hook:** A simple tool that can be made from steel casing, shaped with a cutting torch. A reducing sub connects the top end of the tool to the drill stem. Also used to straighten the lost drill pipe in the hole in preparation for removal by the tap or overshot tools.

**Water Injection System:** Used for adding water to the down-hole air stream, thereby increasing the efficiency of the cleaning action. Also used for controlling dust in the hole.

**Water Table:** That underground level at which water is found.

**Water-Well:** Term used for any type of ground water structure providing space for accommodating water lifting device for drawl of ground water.

**Well Development:** Development of aquifers by compressed air or any other suitable method.

**Wetting Agent:** An additive that reduces surface tension.

**Well Development:** It is a treatment of a well to establish the maximum rate of usable water yield without sand.

**Well Screens:** Well screens are specially fabricated screen pipes from different materials which can have wider range of slot opening from much finer to coarse compared to slotted pipes.

## **23.1 GENERAL REQUIREMENTS**

**23.1.1** Rainwater harvesting is the collection of rainfall. In most cases, a roof is used for this purpose. The rainwater then flows through the gutters, into a collection tank. The collected water can be used for small scale irrigation (of vegetable gardens etc.), clothes washing, bathing and after treatment also for drinking and food preparation.

**23.1.2** Rainwater offers advantages in water quality for both irrigation and domestic use. Rainwater is naturally soft (unlike well water), contains almost no dissolved minerals or salts, is free of chemical treatment, and is a relatively reliable source of water for households

**23.1.3** A rooftop rainwater harvesting system consists the following elements:

- (a) Collection area
- (b) Conveyance/piping system,
- (c) Filtration /treatment
- (d) Storage
- (e) Usage/ Recharge

**23.1.4** The collection area in most cases is the roof of a house or a building. The effective roof area and the material used in constructing the roof influence the efficiency of collection and the water quality.

**23.1.5** A conveyance system usually consists of gutters or pipes that deliver rainwater falling on the rooftop to manholes or other storage vessels. Both drainpipes and roof surfaces should be constructed of chemically inert materials such as wood, plastic, aluminum, or fiberglass, clay tiles etc in order to avoid adverse effects on water quality.

**23.1.6** The water ultimately is stored in a storage tank, which should also be constructed of an inert material. Reinforced concrete, Brick masonry, fiberglass, or stainless steel are suitable materials. Storage tanks may be constructed as part of the building, or may be built as a separate unit located some distance away from the building.

**23.1.7** Design of various component of systems for Rain Water Harvesting are covered in the CPWD Rain Water Harvesting and conservation Manual.

**23.1.8** The specifications of various types of piping systems used in RWH, manholes, manhole covers, Open surface drains, road gully chamber, Dispersion trenches, soak pits are provided in the CPWD specifications Sub Head: Drainage.

**23.1.9** The Specifications for Storage tanks/Underground sumps shall be followed as per IS 2470: 1986 (Part I & II).

**23.1.10** The recharge wells/pits are provided with the bore wells to recharge the ground water table directly draining rainwater through filter media to the aquifer.

**23.1.11.** The recharge wells/pits are also used for drawing water from the aquifer by making deep tub well in the or near the recharge pit.

**23.1.12** The specifications for tube well for the withdrawal of underground water are also provided in this chapter.

## **23.2 TYPE OF TUBEWELLS:**

### **23.2.1 Type 1 (Cavity Well)**

Cavity wells are generally shallow wells drilled in alluvial formations (see Fig. 23.1 and Fig. 23.2). These are wells with casings resting in thick, hard impervious clay layer above the aquifer. It is a prerequisite that the impervious clay layer should be of adequate thickness to support the well and should not disintegrate when water is pumped out.

### **23.2.2 Type 2 (Tubewell)**

Tubewells are generally constructed in alluvial formations comprising a casing pipe, a housing pipe (if need be) and an intake section either screen or slotted pipe with or without gravel packing (artificially packed or naturally packed wells as shown in Fig. 23.3 and Fig. 23.4). These wells may be either under water table conditions or under artesian conditions (see Fig. 23.5).

### **23.2.3 Type 3 (Borewell in Hard Rock Formation)**

The over-burden in such wells is encased to eliminate the risk of caving in. Drilling is further carried out in rock formation and the bore is left normally unsupported to allow the water to flow from crevices and fissures into the bore except in cases where caving formations are encountered (see Fig. 23.6).

**23.3 DRILLING METHODS:** The various terms of water well drilling are to be read as per IS 9439 : 2002. The various methods of drilling as per IS 2800 (Part-I) : 1991 are as below:-

#### **23.3.1 Auger Drilling**

The drilling is done with a spiral or worm auger connected to square rods turned manually with rod tillers, the cuttings produced as a result of drilling are removed with a sand shell. Steel casing pipes with drive shoes at the bottom are lowered as the drilling progresses. This method is employed where very shallow drilling in alluvium formation is involved (see Fig. 23.7 and Fig. 23.8).

#### **23.3.2 Water Jet Boring**

A drill bit with nozzles is attached to the drill pipes at its bottom and through which water is pumped at high pressure. The water on its return flow through the annular space between the bore and the drill pipe, brings out the cutting along with it to the surface. Casing pipe is simultaneously used to avoid caving in. The method is suitable for drilling shallow wells in loose sandy formations (see 23.9).

#### **23.3.3 Calyx Drilling**

A bit made from hollow steel tube with two inclined slots called 'shot bit' is connected below another tube (core barrel) which is further connected to the drill rods. These are rotated mechanically. Chilled shots are fed to the bottom of the bit through the drill string along with water. These are ground by the shot bit to form abrasive material with sharp edges which cuts into the consolidated formation forming an annular ring to form a core inside the core barrel, which is then taken out from well by grouting the core with quartz chips, etc.: This method is successful for shallow tubewells drilling in consolidated formations with large diameter holes.

#### **23.3.4 Percussion Drill Hog**

A heavy bit attached with a drill stem, a drilling jar to a cable is given up and down spudding motion, either manually or by power. Water is added to dissolve the cuttings which are lifted out by means of a bailer. Steel casing pipes with drive shoes are used as the hole progresses. This method of drilling is suitable for drilling in boulder formations.

### **23.3.5 Rotary Drilling**

#### **23.3.5.1 Direct Circulation Method**

A drill bit is rotated mechanically by means of drill pipes, through which drilling mud (usually bentonite mixed with other suitable material) is circulated under pressure. This process of circulation lubricates the bit, carries the cutting in suspension to the surface and also plasters the wall of the hole to prevent it from caving-in. Very deep wells can be constructed in alluvium formations by this method.

The accessories commonly used for tubewell construction, their description/ functions and the typical material for their manufacture are given in Table 1.

#### **23.3.5.2 Reverse Circulation Method**

A starting of drill pipes with a drill bit at the bottom is rotated by mechanical means. Plain water or a fluid of gelling quality depending on the strata conditions, is allowed to flow into the bore hole, when drill cuttings along with water are sucked through the drill pipes by a centrifugal pump and thrown into the setting pit. The hole remains intact under the hydrostatic pressure of the drilling fluid, the level of which is maintained continuously. Large diameter holes can be drilled in alluvium formations by this method.

### **23.3.6 Down the Hole Hammer (DTH) Drilling**

The method is used for fast and economical drilling in hard formations. Compressed air is utilized for rapid impacting action by the hammer to the bit thus crushing the formation into small chips which are flushed out through the annular space between the bore and the drill pipes by the upcoming compressed air.

**Note:-** The drilling bits generally used during the drilling by direct circulation method and by reverse circulation method are tricone rock roller bits, diamond drilling bits, reaming bits and thin wall core bits. Their use depends upon the type of soil formations such as soft, medium hard and hard formations. The bits used for percussion drilling are California pattern bits and for DTH drilling are button bits and drag bits.

## **23.4 ACCESSORIES TO BE USED IN TUBEWELL CONSTRUCTION**

**23.4.1** A typical drawing showing details of bail plug, bail plug hook, centralizer, taper reducer, mild steel clamp, well cap and notch plate, is given in Fig. 23.10.

**23.4.2** The description, functions and the material of accessories commonly used for tubewell construction is given in Table-1.

## **23.5 INFORMATION TO BE FURNISHED BY THE OWNER OF THE TUBEWELL:**

The owner shall furnish the following information to the drilling agency:

- (a) Information regarding tubewells and dug well existing near his land such as their depth, formation encountered and discharge, etc. may be furnished as far as possible;
- (b) Static water level;
- (c) Expected yield;
- (d) Purpose for which the water is needed, such as irrigation, industrial or domestic purpose, etc; and
- (e) Any other information.



### 23.6 INFORMATION TO BE FURNISHED BY DRILLING AGENCY:

When offering to sink a tubewell, the drilling agency shall furnish the owner with the following information:

- (a) Suitability of the site proposed by the owner - (if a more suitable site, other than the one proposed by the owner is available, it should be suggested);
- (b) Whether a test bore hole is proposed and if so, its diameter and depth, and also depth of production tubewell proposed;
- (c) Likelihood of increase or decrease of the depth given at (b) above;
- (d) Method of drilling with size of bore in different depths;
- (e) Types of plain pipe with size, wall thickness and slotted/strainer pipes with opening, may be mentioned;
- (f) Guarantee with regard to the verticality of tubewell and sand content (ppm) in the discharge from the well at the time of handing over;
- (g) Development methods to be adopted may be stated; and
- (h) Any other information and conditions.

**TABLE 1**  
**Nomenclature of Tubewell Parts**  
**(Clause 23.4 and Fig. 1, 2 and 3)**

| Sl. No. | Name of Part             | Description/ Function of Part  | Typical Materials                       |
|---------|--------------------------|--|---|
| (1)     | (2)                      | (3)  | (4)                                     |
| 1)      | Bail plug or bottom plug | A closed socket provided at the bottom most end of the pipe assembly. A simple mild steel plate welded at the bottom end.  | IS 226 : 1975                           |
| 2)      | Bail plug hook           | Inverted 'U' hook attached to the bottom plug or a bar fitted across the blind pipe.   | IS 226 : 1975                           |
| 3)      | Casing pipe              | Placed against strata from which water is not to be tapped.  | IS 4270 : 2001<br>or<br>IS 12818 : 2010 |
| 4)      | Screens/ slotted pipes   | Has openings to permit entrance of water from the aquifer.   | IS 8110 : 1985                          |
| 5)      | Centralizer              | The centralizing guides are fitted to the well assembly except the housing pipe at suitable spacing to keep the assembly in the centre of the hole So that an even thickness of gravel pack.   | IS 226 : 1975                           |
| 6)      | Taper/ reducer           | A taper/reducer is intended to connect the housing pipe with lower diameter assembly down below.   | IS 226: 1975                            |
| 7)      | Housing pipe             | This is the upper portion of the case section of the well and serves as a housing for the pumping equipment and is a vertical conduit through which water flows from the aquifer to the pump. It is water tight and extends from to a depth below the anticipated pumping water level. | IS 226 : 1975                           |
| 8)      | Clamp                    | Fixed at the top of the tubewell for supporting the well assembly.   | IS 226 : 1975                           |
| 9)      | Well cap                 | Used to keep the tubewell closed after its completion until the pump set is installed. It is either threaded to be screwed to top of the housing or simply a plate is spot welded so as to be easily removed when required.  | IS 226: 1975                            |



## 23.7 DESIGN AND LOWERING OF PIPE ASSEMBLY

### 23.7.1 Design of Pipe Sizes and Lengths

The length and diameter of the casing pipe is selected on basis of static water level, the draw down, the discharge expected from the well and the size of pump to be installed. The size and length of slotted/strainer pipes are selected according to the actual requirement according to the strata met with the expected discharge and the depth of tubewell, the casing pipes shall generally conform to IS 4270 : 1983, the slotted/strainer pipes shall conform to -IS 8110 : 1985 and the u-PVC casing pipes and screen shall conform to IS 12818 : 2010.

### 23.7.2 Design of Screen Slots

The entry of water in the tube well shall be either through screens or slotted pipes. Following are the various types of well screens and slotted pipes used in water wells depending upon the type and size of well:

- (a) Plain slotted pipe,
- (b) Bridge slotted pipes,
- (c) Mesh -wrapped screens,
- (d) Cage type wire wound screens,
- (e) Pre-packed resin bonded gravel screens,
- (f) Brass screens.
- (g) u-PVC pipes

The design, selection and type of screen or slotted pipe size and distribution of slots shall be as specified in IS 8110 : 1985.

## 23.8 GRAVEL PACKING

**23.8.1** All gravel to be used as pack in tubewell construction for water supply shall be as specified in IS 4097: 1967. The thickness of the gravel shroud around the screen shall generally be not less than 10 cm.

**23.8.2** The gravel selected for packing tubewells shall consist of hard quartz (about 96 percent SiO<sub>2</sub>) or other suitable material, with an average specific gravity of not less than 2.5. Not more than 10 percent by weight of the material shall have a specific gravity of less than 2.25. The gravel shall contain not more than two percent by weight of thin flat or elongated pieces. In the case of such pieces, the larger dimensions shall not be more than 3 times the smallest dimensions. The quartz shall be of sub-rounded to rounded grains with minimum angular features.

**23.8.3** The gravel for use as pack shall be free from impurities, such as shale, mica, feldspar, clay, sand, dirt, loam, and hematite and organic materials.

**23.8.4** The porosity of the gravel when laid as a pack shall not be less than 25 percent.

**23.8.5 Gravel Sizes:** The gravel conforming to this standard as per IS 4097 : 1967 shall be of the following grades:

| Sl. No. | Grade | Pack          | Particle Size Range Mm | IS Sieves (see IS:460-1962*) |
|---------|-------|---------------|------------------------|------------------------------|
| 1       | A     | Fine Gravel   | Over 2.0 to 3.35       | 2.0 , 3.35                   |
| 2       | B     | Fine Gravel   | Over 3.35 to 4.75      | 3.35 , 4.75                  |
| 3       | C     | Medium Gravel | Over 4.75 to 6.3       | 4.75 , 6.3                   |
| 4       | D     | Medium Gravel | Over 6.3 to 8.0        | 6.3 , 8.0                    |
| 5       | E     | Coarse Gravel | Over 8.0 to 12.5       | 8.0 , 12.5                   |

**Note:-** The particle size distribution of gravel shall be determined by screening through standard sieves in accordance with IS: 460-1985. The percentage distribution of the sizes shall be determined from a graph in which the percentage of material passing through each sieve is plotted against the standard aperture of that sieve. Any size, say D20, will thus indicate that the cumulative weight of all the grains smaller than this size is 20 percent of the total weight of the test sample. The uniformity coefficient of the gravel, that is, the ratio of its D20 to D10 sizes shall not exceed 2. A material with uniformity coefficient less than 2 shall be classified as uniform and if greater than 2 it shall be taken as non-uniform. The limiting sizes given in above table are the minima and maxima, and the stacks containing smaller or bigger sizes as shown by sieve analysis shall be rejected.

**23.8.6** The gravel shall have a hardness of not less than 5 in Moh's scale.

**23.8.7** The pack aquifer ratio ( P/A ratio) is defined as the ratio of 50 percent size ( D30) of the gravel pack to the 50 percent size of the aquifer. The size of gravel when used as pack in tubewells shall be decided in accordance with the size of the aquifer material proposed to be tapped. The gravel size shall be limited as below:

- (a) Uniform aquifer with uniform gravel pack.  
Pack aquifer ratio — 9 to 12.5
- (b) Non-uniform aquifer with uniform gravel pack.  
Pack aquifer ratio — 11 to 15.5

**Note:-**The thickness of gravel pack shall be limited to 13 to 18 cm.

**Note:-** However, artificial gravel pack may not be necessary if the effective size (D10) of the aquifer is greater than 0.3 mm and its uniformity coefficient is greater than 5. For artificial gravel pack, pl see Fig. 23.4.

**23.8.8** For sampling and packing, corresponding provisions of IS 4097 : 1967 may be referred.

**Note1:** In percussion method of drilling, gravel is fed into the annular space between the casing pipe and the assembly pipe up to 3 m above the bottom of the slotted pipe. The well is developed using compressed air or by bailers and as the water becomes clear, surging or backwashing is done to make the development more perfect. More gravel is fed, if necessary, and when the water becomes free from sand, the casing pipe is jacked up to some height, and the process is repeated until all the aquifers are gravel packed.

**Note2:** In rotary method, the pipe -assembly is lowered into position and gravel packing may be done up to a suitable depth below the bottom of the housing pipe in the first instance. There after the gravel packing up to the required depth is completed after keeping the housing pipe vertical within limits. To achieve uniform gravel packing around the pipe assembly inverted cones should be used.

**Note3:** A provision for a well base to eliminate the possibilities of subsidence of the well structure may be incorporated. If the bottom of the well is in a soft formation, the well should be provided with an artificial base for the casing and screen by over drilling the hole about 1 to 2 m and filling the extra depth with concrete or gravel.

### **23.9 DEVELOPMENT OF TUBE WELL**

**23.9.1** The drilled well shall be developed by any of the methods specified in IS 11189: 1985 depending upon the site conditions in order to get maximum sand free yield. The development process shall be continued until the stabilization of sand and gravel pack has taken place.

**23.9.2** The development shall be started as far as possible, from the bottom of the screen because with this the compaction takes place as the work progresses upwards and the overlaying material can move downwards, without much possibility of bridging and should a bridge develop, the development action would usually break it up.

**23.9.3** The development of the tubewell by over pumping should be done at 15 percent to 25 percent higher discharge than the expected discharge from the tubewell, The final discharge should be free from sand with a maximum tolerance of 20 parts of sand in one million parts of water by volume after 20 minutes of starting the pump.

**23.9.4** In case of tubewell for drinking water, the discharge shall be totally sand free. If the discharge is not sand free after 20 minutes of starting the pump, the well shall be redeveloped. In case the discharge is still not sand free even after re-development, the pump set of lesser discharge capacity may be installed to get sand free water suitable for drinking. The turbidity and hardness of water of wells used for drinking purposes, shall be as specified in IS 10500: 1983.

### **23.9.5 Methods of Development:**

**23.9.5.1** Numerous methods of development are available. An important factor in any method is that the development work be started slowly and gently and increased in vigor as the well is developed. All but one method of well development require the application of sufficient energy to disturb the natural formation or filter pack so as to free the fines and allow them to be drawn into the well, and to cause the coarser fractions to settle around and stabilize the screen. This is usually accomplished by the, surging of water into and out of the well and the formation. The exception is hydraulic jetting; which depends upon a high velocity water jet discharging through the screen. The jets disturb both-filter and formation and the water, following the path of least resistance, returns to the well above and below the jets, carrying the fines into the well.

**23.9.5.2** Determination of the adequacy of *development* is largely a matter of experience and judgment but as a general rule if interrupted over pumping or raw hiding is used as a final method of development the degree of development may be estimated from sand samples on each resumption of pumping. On initiation of interrupted pumping, samples shall be taken as frequently as possible as soon as discharge starts at each new rate of pruning. Sampling of this type at each rate of discharge will show the time required for maximum sand content to occur and will serve as a guide to subsequent sampling and development.

**23.9.5.3** Shortly after the period in which maximum sand content Occurs in the discharge for each new rate of pumping, the discharge will become practically sand free until the well is again surged. As raw hiding continues, the maximum amount of sand content will decrease at each discharge time interval until water of low sand content is discharged.

The known methods of well development are listed as follows:

- (a) Over pumping,
- (b) Compressored air,
- (c) High velocity jetting,
- (d) Surge block, and
- (e) Explosives.

### **23.9.5.4 Over Pumping**

**23.9.5.4.1 Continuous over pumping-** The simplest and most common method is removing fines from the formation close to the well screen is by over pumping. By this it is meant, pumping the well at higher capacity than it will be pumped when in regular service say not less than 50 percent above the designed discharge.

When the water is pumped out of the well, there is a tendency of the sand to move in the direction of the well end, and with steady pull in this direction, the finer sand grains will wedge against each other and bridge across openings or voids between coarse grains to a very considerable degree. The only way in which this can be prevented is by 'back washing' which is keeping the water as agitated as far as possible. The method consist in starting and stopping the pump intermittently to produce relatively rapid charges in the pressure heads in the well. This shall be done more effectively with the help of turbine pumps.

The pump is operated with the fullest capacity until it has produced maximum draw- down. It is then stopped, the water recedes rapidly out of the column of the pump and the well is permitted to return to its normal static water level. The procedure is repeated many times until the well is sand free.

**Note:-** Care shall be taken not to start the pump when the shaft is rotating in reverse direction, as this is likely to cause damage to the pump shafts.

**23.9.5.4.2 Interrupted over pumping** - The development process shall include development by interrupted pumping. The pumping shall be done with a pump capable of pumping at rates up to two times the design capacity. The pumping should be carried out in at least five steps. These steps shall include pumping with no check valve or foot valve present. Pumping shall be conducted in five minute cycles, and shall continue a minimum of two hours or until such time as acceptable standards are attained.

**23.9.5.5 Compressored Air**- One of the most commonly used method of developing a tube well is by compressed air. It shall be used either by back-washing method or by open well or surging method,

#### **23.9.5.5.1 Back Washing Method:**

**23.9.5.5.1.1** In the back washing method a 3-way valve is turned to deliver air down the air-line, with the air cock usually open. This pumps water out of the well through the discharge pipe. When the water becomes clear, the supply of air is cut off and the water in the well is allowed to regain its static level. The air cock is then closed and the 3-way valve is turned, so that the air supply is directed down the bypass to the top of the well. This forces the water down out of the casing and back through the screen, breaking down the 'Bridge' of the sand grains. When the water has lowered to the bottom of the drop-pipe, it will not go further, because the air will escape out through the pipe.

**23.9.5.5.1.2** When the air is heard escaping out of the discharge pipe, or when the pressure stops increasing, the supply of air is cut off, and the air cock is opened again to allow the water to reach static level. The 3-way valve is turned and the air supply again directed down the air line to pump the well. This procedure is repeated until the well is thoroughly developed. It is advisable to run a bailer, if practicable. for final cleaning of the well before installing the pump.

The diameter of the drop pipe is usually kept about 5 cm less than that of the well pipe and that of the air line usually varies from 2 to 6 cm.

The hook-up of the equipment for closed well method is shown in Fig. 23.11.

#### **23.9.5.5.2 Open well method:**

**23.9.5.5.2.1** This method of development is a combination of surging and pumping. Large volume of air is released suddenly into the well pipe which produces a strong surging action. Pumping is done as with an ordinary air lift. The success of this method depends on the skillful application of alternating the surging and pumping as per requirements of the well.

The necessary equipments for this method of development consists of:

- (a) Air compressor with air receiver of adequate size
- (b) Drop-pipe and airline in well with suitable means for raising and lowering each independently of the other.

**23.9.5.5.2.2** Normally the well pipe itself is used in place of drop pipe but as the washed material has also to be pumped out along with the water, if required a separate discharge/educator pipe may be used so that velocity of water pumped out may be sufficiently great to carry with it all the clogged material from the well. Use of drop pipe becomes necessary in case of deep wells:

- (a) Flexible high pressure hose and pipe line to connect between tank and airline in well
- (b) The compressor should be fitted with unloaded and the tank must have a relief valve to safeguard against accidental overloading and
- (c) Miscellaneous small fitting, such as pressure gauge and a quick-opening valve at the outlet of the tank.

**23.9.5.5.2.3** In order that development by this method may be fully successful, it is necessary to have a ratio of submergence of at least 60 percent. The efficiency of development reduces rapidly with submergence less than 80 percent should the air line be too deeper submerged in proportion to the net height of the lift, an uneconomically high pressure will be required to force the air out.

The discharge of the compressor shall be piped direct to the tank without any valve in the line. The discharge from the tank to the well shall be the full size of the airline in the well, or if long, the next larger size, and shall be fitted with a quick opening valve near the tank. A high-pressure hose is used between the discharge pipe from the tank and the airline in the well. This hose shall be at least 4.5 to 6 m long to allow sufficient space for moving the drop pipe and air line up and down.

Before blowing water or drilling mud out of the well, the air-lift shall be operated slowly for a time to make sure that the screen is sufficiently open so that water will come into the well freely, otherwise damage to the screen may take place.

**23.9.5.5.2.4** At the start of development the drop pipe is lowered within 600 mm or so of the bottom of the screen, and the airline is placed, so that it is inside the drop pipe by 300 mm or more. If there is plenty of submergence airline needs to be lowered only for enough to get 60 or 70 percent submergence. The air is turned into the airline and the well is pumped in the manner of a regular air lift, until the water appears to be free from sand. The valve between the tank and the airline is then closed, allowing the tank to be pumped full of air up to required pressure. In the meantime, the airline is lowered so that it is 300 mm or so below *the* drop pipe. The quick opening valve is then thrown open, allowing the air in the tank to rush into the well. There will be a brief but forceful surge of the water and then a 'head' of water will 'shoot' partly from the drop pipe. If the airline is pulled back into the drop pipes as soon as the first heavy load of air has been shot into the well, it will produce a strong reversal of flow up the drop pipe which will quite *effectively* agitate the water-bearing formation.

**23.9.5.5.2.5** The well is then allowed to pump as an air lift for a short time, and then another 'head' is shot. repeating until the absence of further sand, etc, shows that the development is complete at this point. This procedure may be repeated in stages at convenient places in the screens, which will complete the work and clean out loose sand which might have settled at the bottom of the well.

The compressor shall be capable of developing sufficient pressure to overcome initial head of water in the air line. The recommended size of pumping pipe, and the size of the airline with the pumping rate is given below for guidance.

| Pumping Rate<br>Litre/min | Size of Pumping Pipe<br>mm | Size of Airline<br>mm |
|---------------------------|----------------------------|-----------------------|
| 450-700                   | 100                        | 30                    |
| 700-900                   | 125                        | 40                    |
| 1125-1800                 | 150                        | 50                    |
| 1800-3200                 | 200                        | 65                    |

This method has its own limitations where the yield is very weak and the draw down rapid or where submergence is low.

Hook-up for open well method is shown in Fig. 23.12.

### 23.9.5.6 High Velocity Jetting:

**23.9.5.6.1** Jet development is a recent addition to other common methods of developing wells. In this method water jets projected at high velocity out through well screen openings effectively loosen fine sand, silt and drilling mud from the water bearing formation. The loosen material moves inside the well screen and is removed from the well by pumping or bailing.

The jetting tool consists of an attachment fitted with two or more evenly spaced horizontal nozzles having 6.2, 9.5 or 12.7 mm orifices. The bottom of the tool is closed and the depth of setting, the choice of the nozzle depends largely on the capacity of the high pressure pump. The main item of equipment needed for this method are the jetting tool, high pressure pump, hoses and connections, 5 cm dia pipe line and a source of water. The size of the pipe for feeding water to the nozzles should be large enough to keep friction losses to a reasonable value. It generally ranges from 4.0 to 7.5 cm depending upon the length of the pipe and discharge it has to carry.

The diameter of the jetting tool shall be about 25mm less than the inside diameter of the screen. The normal jet discharge ( per nozzle) and velocity is as indicated below:

| Nozzle<br>Orifice<br>mm | Pressure 7kgf/cm <sup>2</sup> |                     | Pressure 14kgf/cm <sup>2</sup> |                     | Pressure 17.6kgf/cm <sup>2</sup> |                     |
|-------------------------|-------------------------------|---------------------|--------------------------------|---------------------|----------------------------------|---------------------|
|                         | Velocity<br>m/sec             | Discharge<br>lt/min | Velocity<br>m/sec              | Discharge<br>lt/min | Velocity<br>m/sec                | Discharge<br>lt/min |
| 6.20                    | 33.50                         | 17                  | 46                             | 118                 | 55                               | 90                  |
| 9.50                    | 33.50                         | 172                 | 46                             | 255                 | 55                               | 280                 |
| 12.70                   | 33.50                         | 305                 | 46                             | 450                 | 55                               | 500                 |

**23.9.5.6.2** The procedure consists of operating a horizontal water jet inside the well in such a way that the high velocity stream of water shoot out through the screen openings. By slowly rotating the jetting tool and gradually raising and lowering it, the entire surface on the outside of screen gets the vigorous action of the jet. Fine sand, slit and clay are washed out of the water-bearing formation and the turbulence created by the jet rings these fine materials back into the well through screen openings above and below the point of operation. Wherever possible, it is desirable to pump the well lightly at the same time as the high velocity jet is working by using air compressor. The water so pumped can be reused for jet-development after pumping it into a setting tank.

### 23.9.5.7 Surge Blocks:

**23.9.5.7.1** An effective method for developing the well is surging created by the rapid up and down motion of a plunger, operated in the casing pipe provided above the screened portion of the well. The rapid motion of the plunger causes forceful reversal of the movement of water, which prevents the bridging of finer particles. The repeated application of the surging force draws fine particles from the aquifer and thus porosity and permeability of the zone around the screen is increased.

A surge plunger is most used tool for development particularly in wells drilled by cable tool methods and tubewells of natural gravel pack well where strainers have been used.



**23.9.5.7.2** Yet there is another method which is called 'Swabbing' in which the swab is lowered into the casing to any selected point and then pulled upwards to produce an inward flow. Swabbing therefore, helps in taking out the fine material drill in consolidated rock aquifers, but are very seldom used in screened wells. Sand pumps may also accomplish effective development of shallow wells with cable tool methods.

**23.9.5.7.3** Where the aquifer contains many clay streaks use of plunger block is not recommended because this can cause the clay to plaster over the strainer surface and thus clog the strainer resulting in reduced discharge. Sometimes the strainer give away due to high differential pressure when the strainer is clogged with clay.

After the sand has been drawn in by the surge block the well is cleaned by using a hailer and the process is repeated till the well is totally sand free. Total time involved for developing may range from four hours for a small well to 3-4 days on large well with longer screen.

The size of the plunger shall be kept such that it does not fit in the casing pipe. It shall be able to pass within the pipe and its fittings freely. The plunger may be run on a continuous string of pipe or a part string with a cable adopter at the top. The surging plunger is lowered into the casing about five metres below the water. The movement of the plunger should be restricted in the portion above the screen in the casing pipe. After lowering, it is stroked to produce surging effect. The stroking may come off the beam of a percussion drill or off a cat head or by hand tripping. Some time, hoisting mechanism is used for this. Initially, the surging shall be stated slightly and gradually increased till it reaches the maximum limit of the system. Through bailing between the runs of the plunger is very important for efficient development. The surging and bailing out is carried out till little sand is driven into the well. In case of wells with long screens, surge plunger may, however, be operated inside the screen for effective development. A typical surge block has been shown in Fig. 23.13.

**23.9.5.8 Explosives** - These are sometimes employed to develop and enlarge cervices and fissures in tubewells drilled in hard rocks. Charges of 14 to 230 kg are used according to the hardness of the rock and the depth at which the charge is to be detonated.

**23.9.6 Criteria for Proper Development of Tubewells** - Development work is an essential operation in the completion of drilling job. It consists of steps to remove the finer material and opening up the passage in the formation so that water can enter the well through the screen more freely. Proper development is said to have been satisfactorily done when:

- (a) The stabilization of the sand formation has taken place, that is, there is no further sinking of gravel and the discharge is sand free; and
- (b) Permeability of the formation is increased by removing finers utilizing proper development method.

**23.9.7** After completion of development by over- pumping, the well shall be tested for its performance that is yield characteristics and efficiency. This shall be achieved by conducting a step draw down test-determine draw downs at the end of the hour by pumping at 3 to 4 different rates of discharge.

## **23.10 DISINFECTION**

**23.10.1** The well shall be disinfected after completion of test for yield. All the exterior parts of the pump 'coming in contact with the water shall be thoroughly cleaned and dusted with powdered chlorine compound. In fact it should be disinfected every time a new pump is installed or the one replaced after repairs.

**23.10.2** A stock solution of chlorine may be prepared by dissolving free chlorinated lime. For obtaining an applied standard concentration of 50 ppm. One litre of the stock solution should be used to treat 300 litres of water.

**23.10.3** In -case of water-wells for drinking water purposes, the quality of water should be as laid down in IS 10500: 1983.

### **23.11 GROUTING AND SEALING**

**23.11.1** Grouting and sealing of tubewell may be done, if required by the owner, depending upon the site conditions and quality of the discharge of the strata encountered. To ensure that the grout will provide a satisfactory seal, it should be applied in one continuous operation. Sealing of the tubewell may be done by grouting the annular space between bore and the housing pipe, thickness of grouting depending upon the quality of water. In case of tubewells for drinking purposes, grouting and sealing shall always be done to ensure safe sanitary conditions.

**23.11.2** It is desirable to plan an oversize bore hole of 7.5 to 15 mm more than the diameter of the well casing to an adequate depth during the design of well itself. The depth to be grouted varies with geologic and site conditions but a depth of 3 to 4.5 m from the surface is generally adequate.

**23.11.3** Surface Apron -An apron around the well and sloping away from it protects the well from pollution caused by contaminated water flowing back into it and prevents muddy pools of standing water forming around the well.

### **23.12 HANDING OVER OF THE TUBEWELL**

**23.12.1** The tubewell should be handed over to the owner in a complete shape. The housing pipe should be closed by a well cap for the period between the completion of the tubewell and the installation of the pump set.

**23.12.2** The following information shall be furnished by the drilling agency on completion of the tubewell:

- (a) Total depth of tubewell drilled,
- (b) Strata chart of the tubewell indicating different type of soil formations met with at different depths and indicating the depth of each type of soil formation,
- (c) Samples of strata collected, neatly packed and correctly marked in sample bays,
- (d) Position of every joint in well assembly,
- (e) Method used for development,
- (f) Total hours of development done,
- (g) Developed discharge in LPS,
- (h) Discharge is totally sand free or presence of sand particles is there,
- (i) P.P.M. and turbidity after development,
- (j) Pumping water level at developed discharge, and
- (k) Static water level.

**23.12.3** A typical proforma is given in Annex A to furnish the details given in 23.12.2.



**INFORMATION TO BE FURNISHED BY DRILLING AGENCY TO OWNER ON COMPLETION OF TUBEWELL (As per para 23.12.2)**

1. Agency drilling the tubewell.....
2. Location of the tubewell.....
3. Method of drilling adopted.....
4. Date of starting.....
5. Date of completion.....
6. Pilot hole or test hole.....Bit siz.....  
Bit type.....Hours.....from.....to.....
7. Coring done.....Bit size.....bit.....from.....to.....
8. Reaming.....Bit size.....Bit type.....Hours.....from.....to.....
9. Lithological data.  

| From  | To    | Formations |
|-------|-------|------------|
| ..... | ..... | .....      |
| ..... | ..... | .....      |
10. Total depth of tubewell drilled.....
11. Assembly of production well.....size.....length.....Type.....  
 Perforation per meter.....  
 Housing pipe.....  
 Blind pipe.....  
 Strainer.....  
 Bail plug.....
12. Top of tubewell above / below ground level.....
13. Size of gravel.....Quantity used before  
development.....Quantity used during development.....
14. Method used for development.....  
Total hours of testing.....
15. Development discharge.....
16. Turbidity.....
17. Further details appended :  
 (a) Samples of strata, neatly packed in sample bags.  
 (b) Chart of pipe assembly lowered, and  
 (c) Results of mechanical analysis of samples of unconsolidated strata.
18. Remarks :  
 Owner .....Driller.

# CAVITY WELL & TUBE WELL

Sub Head : Rain water Harvesting & Tubewells  
 Clause : 23.2

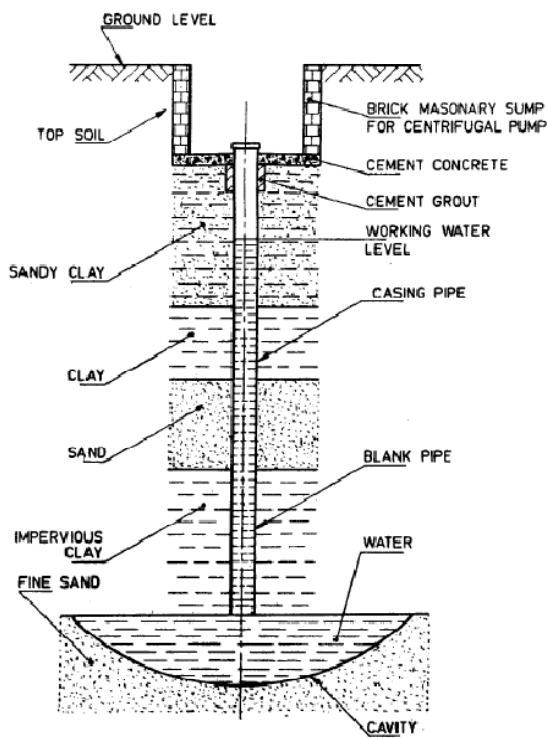


FIG. 23.1 CAVITY WELL (FOR CENTRIFUGAL PUMP)

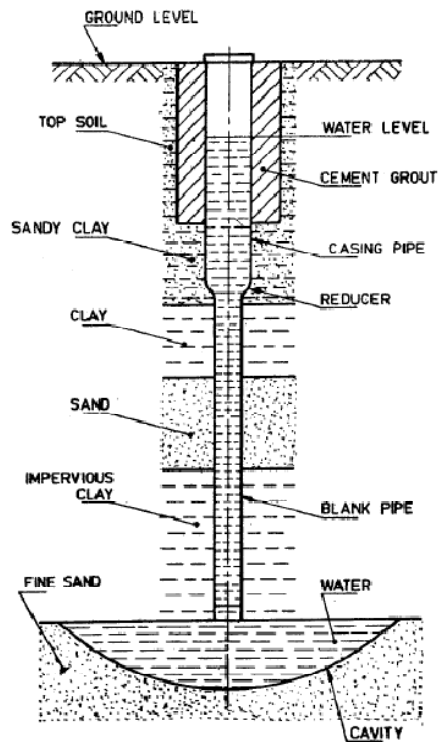


FIG. 23.2 CAVITY WELL (FOR TURBINE SUBMERSIBLE PUMP)

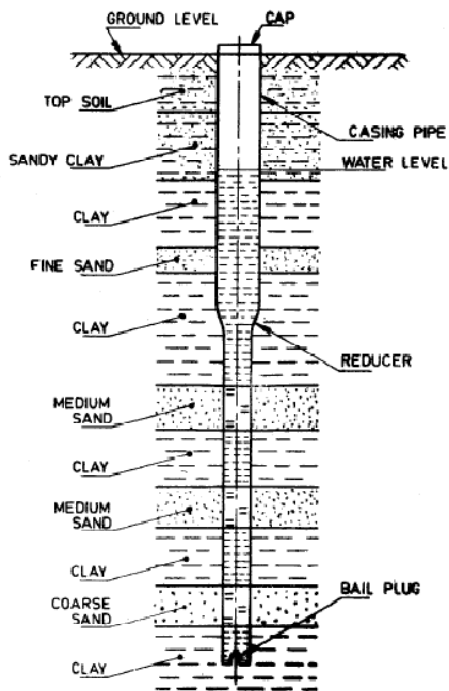


FIG. 23.3 TUBEWELL (NATURAL GRAVEL PACK)

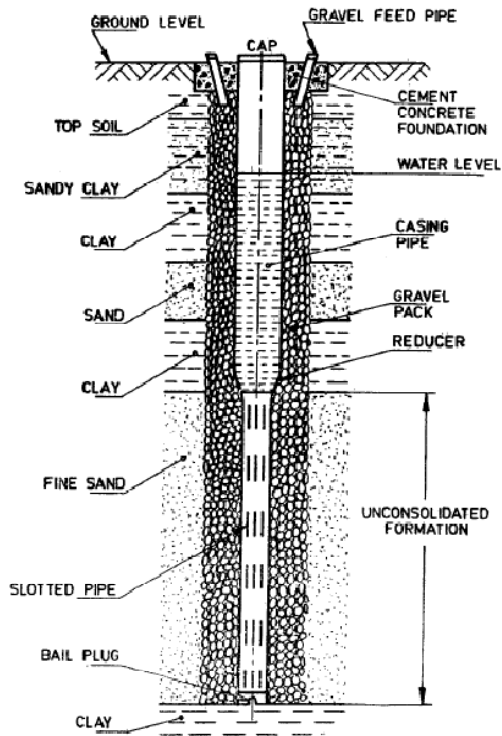


FIG. 23.4 TUBEWELL (FOR ARTIFICIAL GRAVEL PACK)

## TUBE WELL & BORE WELL

Sub Head : Rain water Harvesting & Tubewells  
 Clause : 23.2.2 & 23.2.3

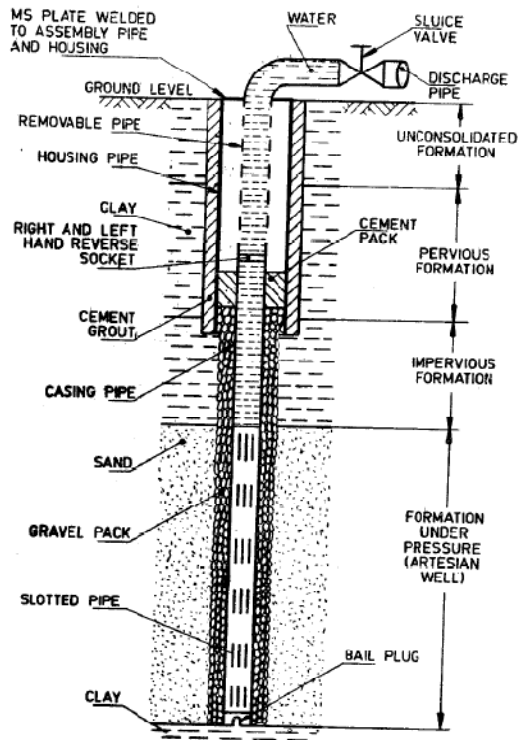


FIG. 23.5 TUBEWELL (ARTESIAL FLOWING)

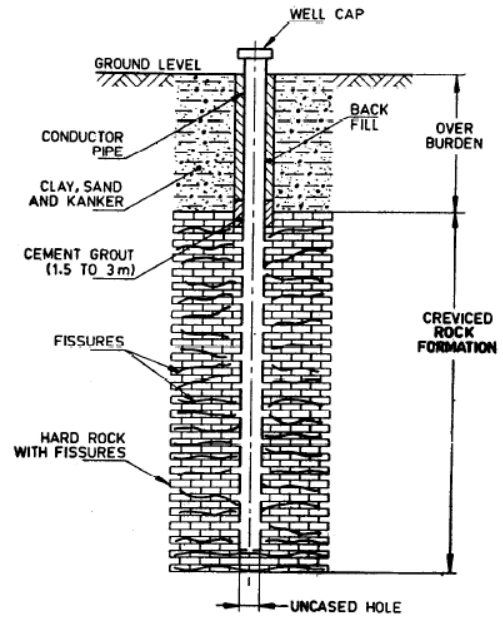


FIG. 23.6 BOREWELL IN HARD ROCK

## AUGERS

Sub Head : Rain water Harvesting & Tubewells  
Clause : 23.3.1

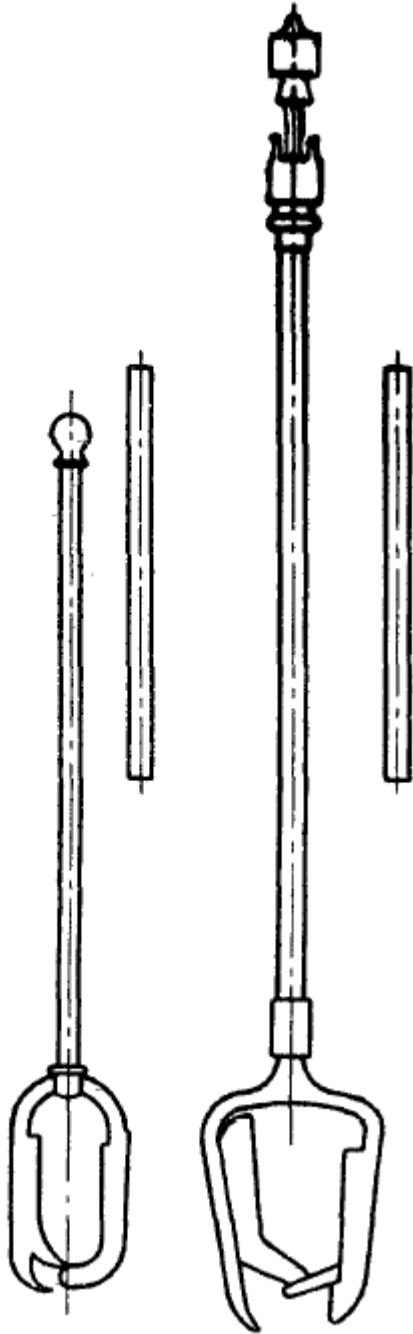


FIG. 23.7 HAND AUGER

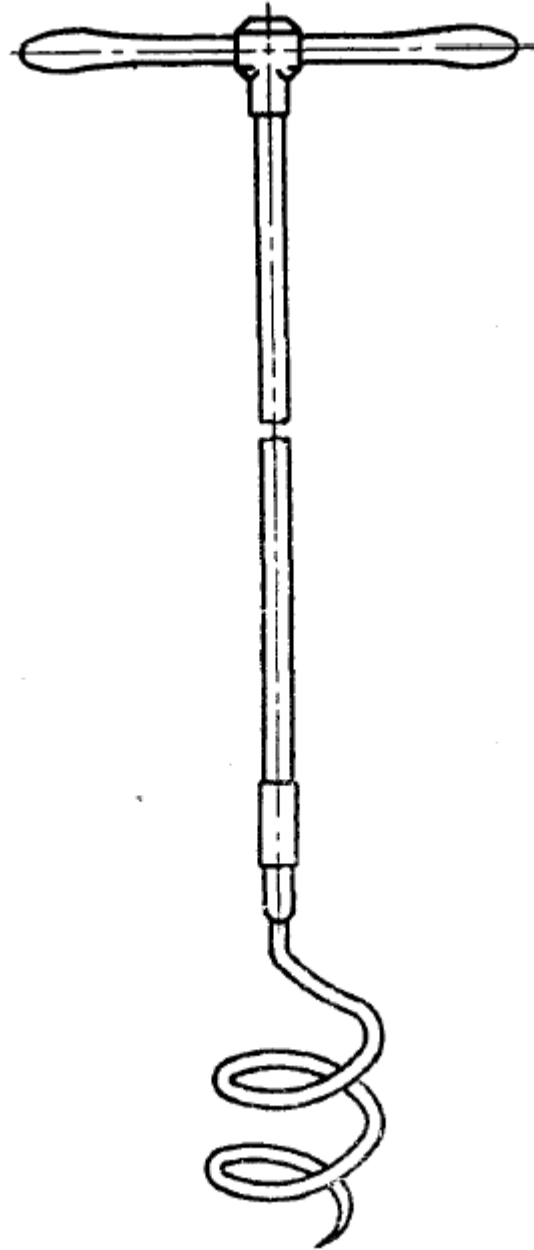


FIG. 23.8 SPIRAL AUGER OR RAM'S HORN

# SIMPLE JETTING RIG

Sub Head : Rain water Harvesting & Tubewells  
Clause : 23.3.2

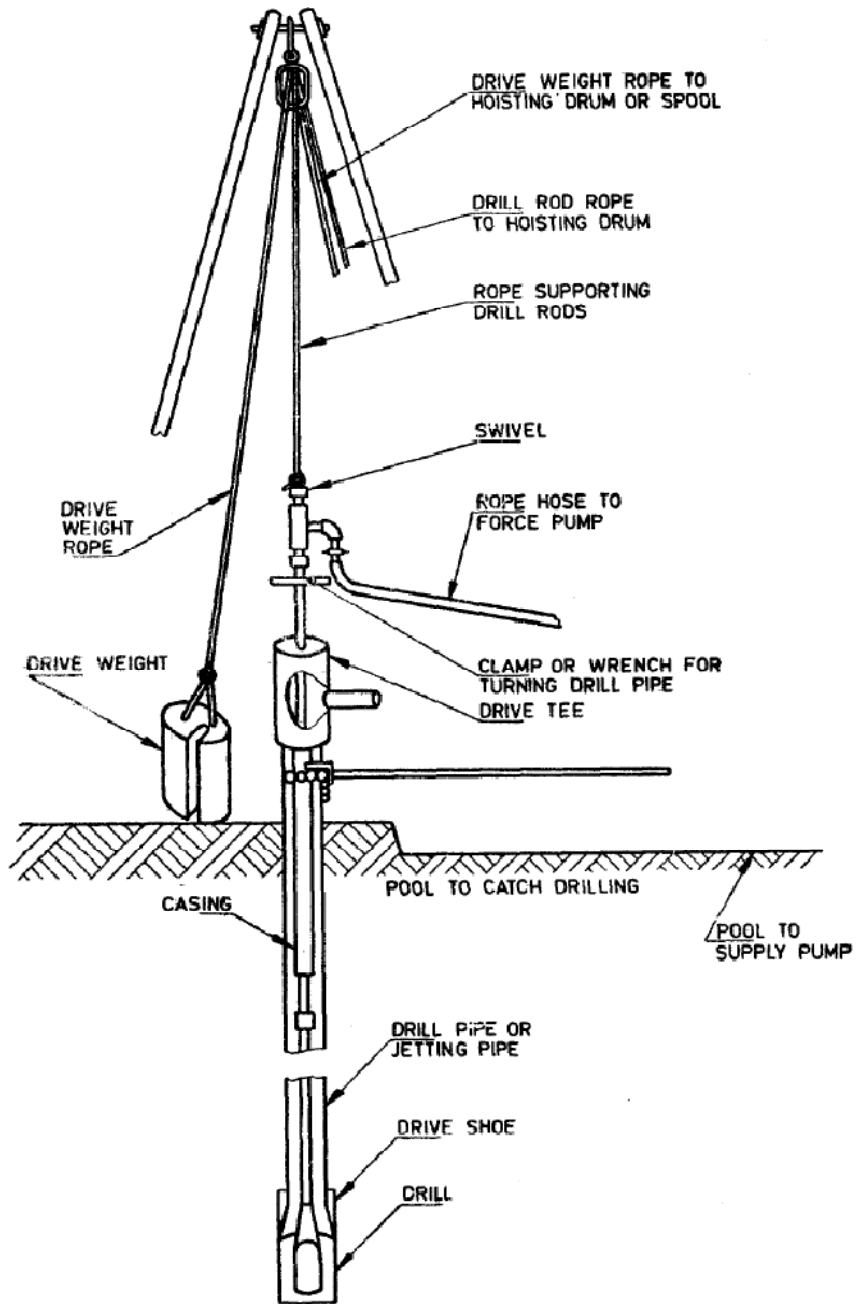


FIG. 23.9 SIMPLE JETTING RIG

# TYPICAL DETAILS OF TAPER REDUCERS, WELL CAP, V-NOTCH PLATE, CENTRALIZING GUIDE, BAIL PLUG AND CLAMP

Sub Head : Rain water Harvesting & Tubewells  
 Clause : 23.4.1

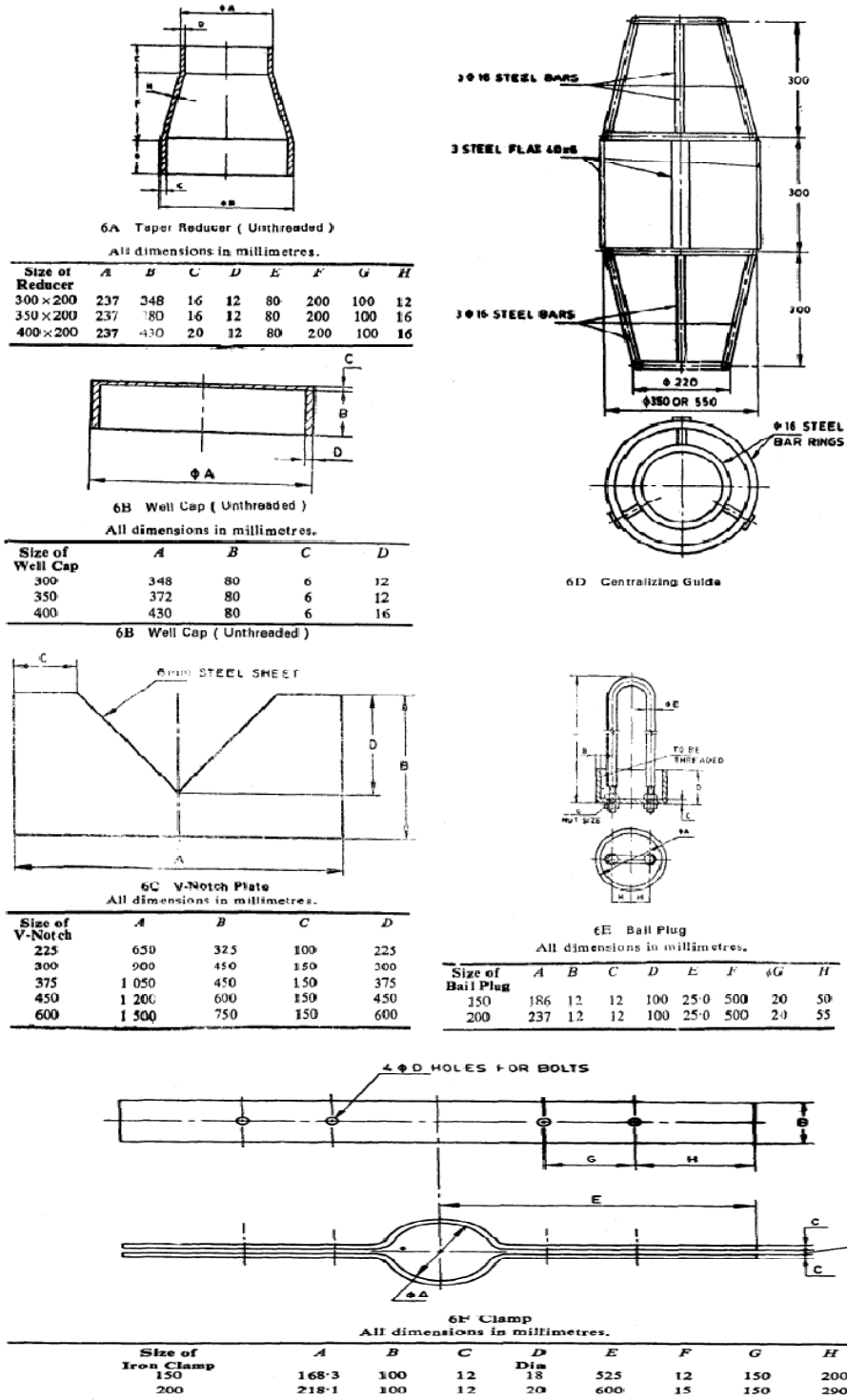


Fig. 23.10 : Typical Details Of Taper Reducers, Well Cap, V-Notch Plate, Centralizing Guide, Bail Plug And Clamp

# CLOSED WELL DEVELOPMENT WITH AIR COMPRESSOR

Sub Head : Rain water Harvesting & Tubewells  
Clause : 23.9.5.5.1

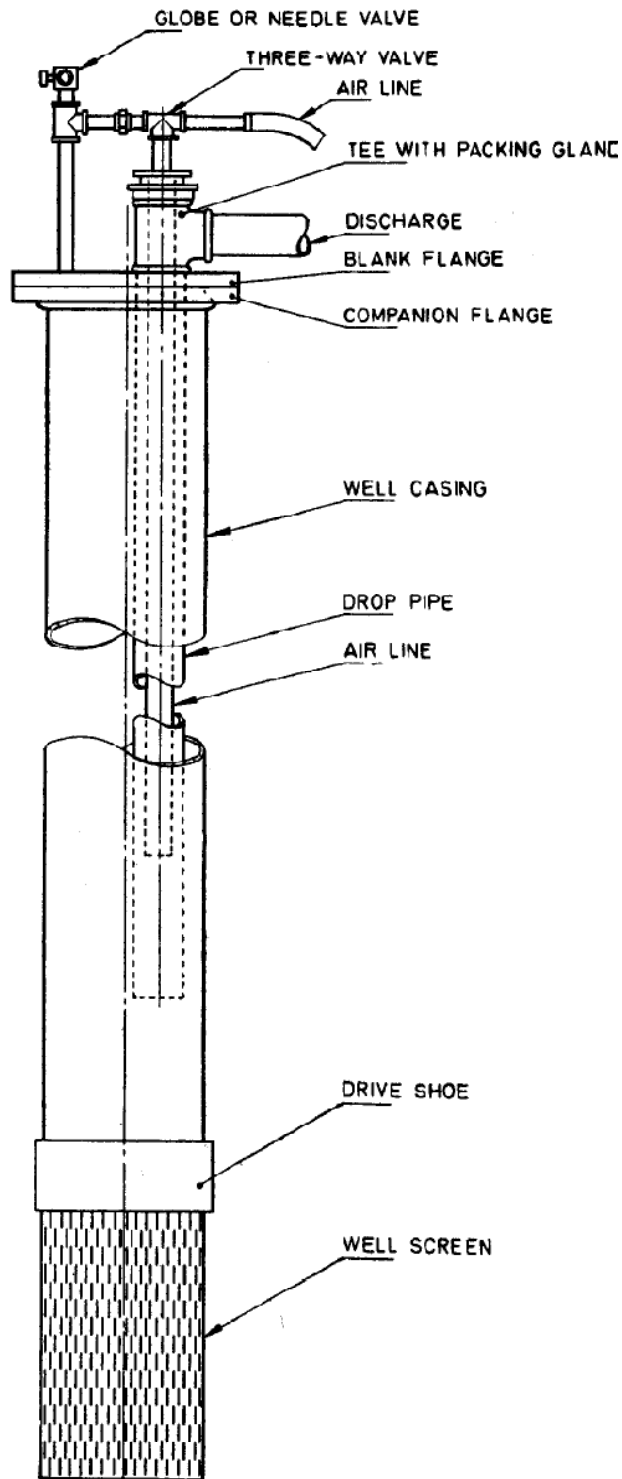


Fig. 23.11 Closed Well Development with Air Compressor

# OPEN WELL DEVELOPMENT WITH AIR COMPRESSOR

Sub Head : Rain water Harvesting & Tubewells  
Clause : 23.9.5.5.2

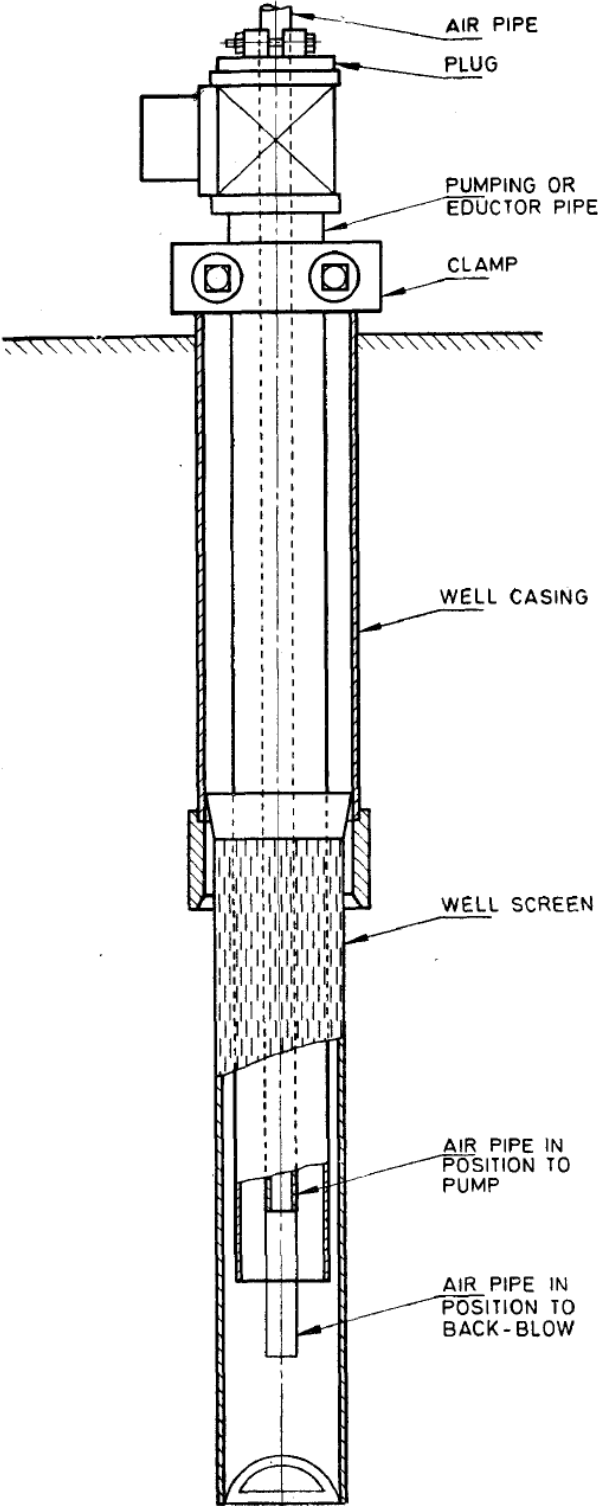


FIG. 23.12 Open Well Development with Air Compressor



# SURGE BLOCK

Sub Head : Rain water Harvesting & Tubewells  
Clause : 23.9.5.7

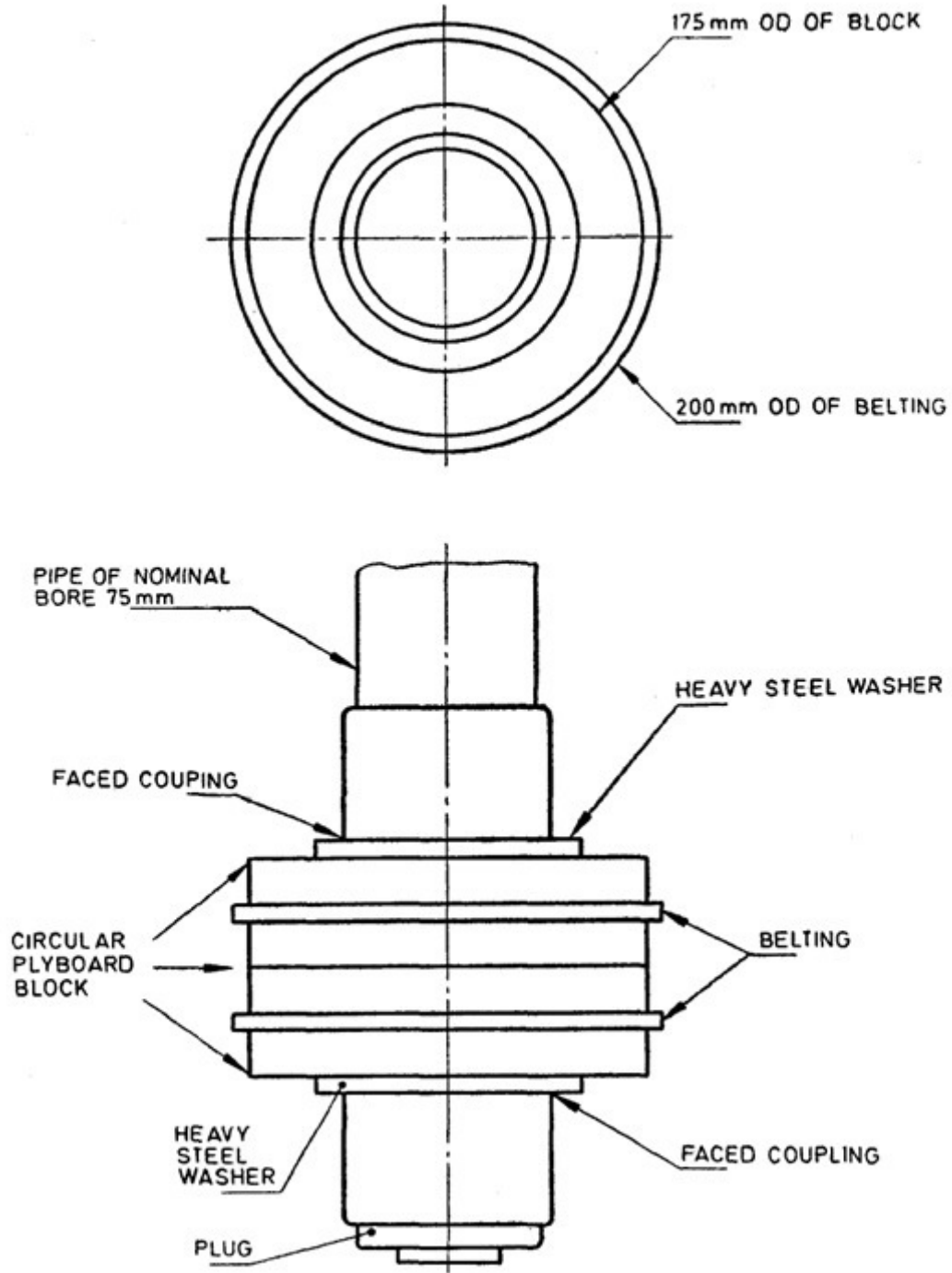


Fig. 23.13 Surge Block

**SUB HEAD : 24.0**

**CONSERVATION OF HERITAGE  
BUILDINGS**



## CONTENTS

| <i>Clause No.</i> | <i>Brief Description</i>  | <i>Page No.</i> |
|-------------------|---|-----------------|
|                   | List of Bureau of Indian Standards Codes                                    | 1245            |
| 24.1              | Raking Of Joints  | 1246            |
| 24.2              | Double Scaffolding System (Cup Lock Type)                                   | 1249            |
| 24.3              | Chemical Cleaning of The Stone Masonry                                      | 1249            |
| 24.4              | Anti-Fungal Wash of The Stone Masonry                                       | 1250            |
| 24.5              | Ruled / Flush Pointing on Red Sand Stone Work                               | 1251            |
| 24.6              | Ruled / Flush Pointing on White Sand Stone Masonry                          | 1253            |
| 24.7              | Stone Surface Strengthening by Using Chemicals                              | 1254            |
| 24.8              | Reduction of Moisture Absorption by Stone Masonry by Application Of Sealers | 1255            |



**LIST OF BUREAU OF INDIAN STANDARD CODES**

| <i>S. No.</i> | <i>BIS. No.</i> | <i>Subject</i>                               |
|---------------|-----------------|--|
| 1.            | IS 533          | Gum Spirit of Turpentine (Oil of Turpentine) |

## 24.0 CONSERVATION OF HERITAGE BUILDINGS

**24.0** The rich cultural heritage of the country ranging over millenniums is testimony to our glorious history and one of the most ancient civilizations of the world. These historical buildings and monuments located through length and breadth of the country symbolizing the social, religious and cultural developments during different periods of history are made of different building materials having specific structural design. The built cultural heritage located in different parts of the country exposed to different climatic conditions is equally varied in its range and content. There are rock- shelters; rock- cut caves, monasteries made of adobe, brick structures, monuments made in ashler masonry, temple, fort, palatial buildings of Mughal architecture and so on. In addition there are structures buried in the earth, some of which have been exposed.

The ravages of time and various weathering agencies through physical - chemical processes by interaction between the environment and mineral compounds of the substratum have been responsible for the deterioration of built cultural heritage. The synergic human factors combined with changes in the environmental scenario around monuments located in the urban and semi urban areas have added new challenges in the conservation field. In view of diverse nature of problems and their varying magnitude in different cases, the maintenance and conservation of monuments is a challenging job.

### **Ethics of conservation:**

A careful preservation and protection of something is its conservation. The objective of conservation is to prolong the life of cultural inherited property and if possible, to clarify the artistic and historical message therein without the loss of authenticity. The Engineer in Charge related to the conservation should have a flexible pragmatic approach based on cultural consciousness, proper training, sound judgment and a sense of proportion with an understanding of the community needs.

### **Conservation of cultural heritage:**

It involves protection and restoration using “any methods that prove effective in keeping that property in as close to its original condition as possible for as long as possible.

Conservation of cultural heritage applies simple ethical guidelines:

- Minimal intervention;
- Appropriate materials and reversible methods;
- Full documentation of all work undertaken.

### **Aim of Conservation:**

Aim of conservation is not to produce what has been defaced or destroyed but to save what is left from further injury or decay and to preserve it as a national heirloom.

### **Basic Principals of Conservation of Heritage Structures:**

Approach to the conservation works to be carried out is laid down as under:

- (i) Hypothetical restorations are unwarranted, unless they are essential for the stability of a building/ structure.
- (ii) Every original member of a building/ structure should be preserved intact and dismantling and reconstruction should be undertaken only if a structure cannot be otherwise maintained.
- (iii) Restoration of carved stone, carved wood or plaster molding should be undertaken only if artisans are able to attain the excellence of old.

## **24.1 RAKING OF JOINTS**

### **24.1.1 Preparation of Surface:**

The purpose of surface preparation is to remove all kinds of loose material, debris, leaves, paper etc. from the surface where raking of the joints is to be carried out for re-plastering or re-pointing the stone masonry as the case may be.

**24.1.1.1** The surface should be cleaned with brooms to remove of any loose material like dirt and dust. Now, the surface should be cleaned by using high pressure Jet machines having dual benefit of removal of the loose material and softening of the mortar in the stone masonry. Every effort should be made to avoid dust nuisance.

### **24.1.2 Safety:**

Contractor shall be advised to ensure that all workers should wear helmets, safety belts, proper shoes, tight clothes etc. while working at all heights including working on domes etc. Every effort should be made to avoid free falling of the material and necessary protection should be provided along the scaffolding (if any).

Care shall be taken by the agency to avoid any damage to the heritage building. If any structural or aesthetic damage is caused to the building the same shall be made good by the agency at its own cost and nothing extra shall be paid for this.

### **24.1.3 Tools and Plants (T&P)**

Agency will provide all the requisite tools and plants like hammer & chisel for manual raking and Power or Pneumatically driven mechanical mortar raking equipments of approved manufacturers' as per site conditions and as per directions of the Engineer-in-charge.

The agency will take prior permission of the Engineer-in-Charge to use Power or pneumatically driven mechanical mortar rakers depending upon the noise level that can be approved in the area where work is to be carried out. The work should be carried out in most professional manner so that no interference is caused to the working of various offices/residences housed in or in the vicinity of the heritage building.

Mechanical Jet Spray machines of requisite power shall be procured by the Agency and also shall make own arrangement of the water for the purpose.

To ensure efficient and effective functioning, all T&P must be checked on-site at regular intervals and work must not hold up for want of repairs of the T&P.

### **24.1.4 Skilled Site Personnel**

Only skilled workers shall be employed by the contractor. They must possess knowledge of working in heritage buildings and must have required special training and/or practical experience in executing such works. At least the supervisory staff and major workers should have requisite expertise in the field.

### **24.1.5 Scaffolding**

Scaffolding shall be strong to withstand all dead, live and impact loads which are likely to come on them. Scaffolding shall be provided to allow easy approach to every part of the work.

**24.1.5.1 Double Scaffolding:** Where the joints in the masonry of heritage building are to be exposed by raking, manual or mechanical, double scaffolding system (cup & lock type) shall be provided in the interior as well as exterior side of the building wherever it is feasible/ required to provide the scaffolding system. The scaffolding system shall be stiffened with bracings, runners, and connectors etc. to secure it to the building. Size of the members shall be dependent upon the height at which raking of the joints is to be done.



#### **24.1.6 Raking of Joints**

Proper working space/platform shall be provided to the workers by providing scaffolding (if required) so that raking of the joints could be done easily. The surface where raking of joints is to be done, shall be clearly marked with chalk or any other material, so that it can be easily distinguished.

Raking with hand tools like hammer and chisel shall be resorted to in case the location is not easily accessible for mechanical equipments, sufficient power supply is not ensured or the area is too small to be economical for mechanical raking.

Raking of joints should progress from one end to other first raking the one horizontal joint at a time to the requisite depth as decided by the Engineer-in-Charge. Then next horizontal joint is taken up and so on. Once all horizontal joints are raked up vertical joints shall be raked from either ends. The raked joints are then cleaned by brushing and watering.

The debris/rubbish shall be collected in most professional manner and disposed of to the dumping ground up to 50metres lead or as per direction of the Engineer-in-Charge.

The whole process shall be considered complete if approved from the Engineer-in-Charge.

#### **24.1.7 Measurements**

1. Length and breadth shall be measured correct to a cm and its area shall be calculated in square metres up to two places of decimal.
2. For jambs, soffits, sills etc. for opening not exceeding 0.5 sqm each in area, ends of joists, beams, posts, girders, steps etc. not exceeding 0.5 sqm each in area and opening not exceeding 3 sqm each deductions and additions shall be made in the following way, in case of raking on external face only.
  - (a) No deduction shall be made for ends of joists, beams, posts etc. and openings not exceeding 0.5Sqm each, and no addition shall be made for reveals, jambs, soffits, sills, etc. of these openings.
  - (b) Deductions for openings exceeding 0.5 sqm but not exceeding 3 sqm each shall be made as follows and no additions shall be made for reveals, jambs, soffits, sills, etc. for these openings.
  - (c) When both the faces of the wall are raked deduction shall be made for one face only.
  - (d) When only one face is raked deduction shall be made from one side of frame for doors, windows, etc. on which the width of the reveal is less than that on the other side, but no deduction shall be made from the other side.
  - (e) Where width of reveals on both faces of wall is equal, deduction of 50% of area of opening on each face shall be made from the raked area.
  - (f) For opening having door frame equal to or projecting beyond thickness of wall, full deduction for opening shall be made from each pointed face of wall.
3. In case of openings of area above 3 sqm each, deduction shall be made for the openings, but jambs, soffits and sills shall be measured.

#### **24.1.8 Rates**

The rate shall include the cost of all materials and labour/equipments involved in all the operations described above except Scaffolding which if required and provided shall be paid for separately).

## **24.2 DOUBLE SCAFFOLDING SYSTEM (CUP LOCK TYPE)**

The specifications shall be same as Clause 14.33 read with Clause 5.2.3.2 of CPWD Specification 2019.

## **24.3 CHEMICAL CLEANING OF THE STONE MASONRY**

Clean and well maintained heritage buildings are always admired by all. With the passage of time, staining of heritage buildings are caused by a number of elements such as metals, asphalt, smoke, oil, grease, bird droppings, organic growth etc. due to which they appear neglected. In order to maintain the buildings important and attractive from heritage point of view these need to be cleaned of the stains. It should however be kept in mind that the heritage/historic buildings are there not for our use and enjoyment but also for the future generations. The overriding consideration should always be to limit the cleaning to the bare minimum. Much damage has been done to the building by over cleaning. The gentlest means of cleaning should therefore be adopted.

Cleaning help to preserve masonry by eliminating heavy accumulation of surface dirt which stop evaporation of moisture from within the masonry, thus, from within the masonry. Careful cleaning procedure can remove harmful atmospheric deposits and help to slow the decay. Careful cleaning can make the existing damage more visible therefore, corrective measures can be taken.

### **24.3.1 Material**

Cleaning the stone masonry can be done by the following three ways:

Water cleaning

Chemical Cleaning

Abrasive Cleaning

All these methods can be combined to attain optimum results. The selection of materials to be used depends upon the type of masonry.

#### **24.3.1.1 Acidic Cleaners:**

Hydrofluoric acid (HF) is the only acid that does not form dangerous soluble salts during the cleaning process. However, acidic cleaners as suggested by ASI or as approved by Engineer-in-Charge can be used. These are exceptionally dangerous to use and have to be handled with extreme care. Gloves and full body protection must be worn. These should never be used at concentrations exceeding 5 percent. Acidic cleaners are used on Strong sand stones. These should never be used on polished stones like granite, glass and marble.

#### **24.3.1.2 Alkaline Cleaners**

Ammonium Hydroxide (Ammonia in water solution) is an alkaline cleaner which can be used on calcareous material like marble. Many other commercial cleaners are based on Sodium Hydroxide (Caustic Soda) are available in Market can also be used.

#### **24.3.1.3 Abrasive Cleaners**

This involves wet or dry sand or grit blasting, dry brushing and manual abrasion. Excessive pressure and lack of precision and control may result in the destruction of the surface. Hence, wet grit/sand blasting methods should be used with skill and care to get the desired results.

### **24.3.2 Tools and Plants**

High Pressure Jet Machine with accurate Pressure regulators and gauges is required to produce nebulized water mist through its nozzle, plastic or soft bristle brushes, brooms etc. The water pressure should be controlled by gauges and regulators depending upon the type of stone.

### **24.3.3 Chemical Cleaning**

The chemical cleaning should first be tested on a small area to establish the amount of cleaning required and feasibility of the system and optimal strength and combination of various components. The test area should be so selected that it represents the requisite soiling or staining. The occupants of the building should be forewarned. Sufficient provision for safe scaffolding, plant, clean water supply, safe storage of the materials and removal of debris be made at site before commencement of the chemical cleaning. Glass, painted and polished surfaces should be protected by applying peelable plastic compound, polythene sheets or hardboard sealed at the edges.

The washing should start by mixing requisite quantity of Ammonia chemical not more than 5% concentration or Teepol or any other chemical approved by ASI and/or Engineer-in-Charge mixed with fine sand/silica. The pressure of the Machine should be maintained so that misting (which uses little water) is achieved. The spray should be applied at an angle so that it removes the stains easily. Right Angled jets destroy the surface, hence, better to avoid. The jet should be applied till the requisite cleaning is not obtained.

After Chemical cleaning the surface should be rinsed with clean water. Efforts should be made to remove all the chemicals to avoid damage to the masonry. Any splashes on doors, windows, polished etc. shall be made good by the agency at own cost and nothing extra shall be payable on this account.

### **24.3.4 Measurements**

Length and breadth of the surface of stone masonry cleaned shall be measured correct to a cm and its area shall be calculated in square metres up to two places of decimal. No deduction is to be made for any openings in the range of 0.5 Sqm and nothing extra shall be payable for providing protective films on doors, windows etc.

No deduction shall be made for the jali work as well.

Nothing extra shall be paid for ornamental work of any nature up to a radius of 3.00 Metre.

### **24.3.5 Rates**

The rate shall include the cost of all materials and labour/equipments involved in all the operations described above (Scaffolding, if required to be provided, shall be paid for separately).

## **24.4 ANTI-FUNGAL WASH OF THE STONE MASONRY**

Bio-deterioration prevailing in stone monuments and historical buildings is a well recognized problem existing in tropical regions or environment like India, where due to environmental factors in the form of high temperature, high relative humidity levels and also to the some extent heavy rainfall causes the bio-deterioration and bio-weathering favour the growth and simultaneously allows living various organism (micro and macro) to remain on stone surfaces because there are no natural or environmental treatment is found so far to protect the stone unless and until the monuments are given chemical treatment for sustainability.

In order to avoid attack by fungus on the heritage buildings anti-fungal wash treatment is done using 3% solution of sodium penta-chloro-phenate of reputed brand and manufacturer on cleaned stone masonry. Sodium penta-chloro-phenate is a chlorine compound having herbicidal, fungicidal and bactericidal applications.

### **24.4.1 Materials:**

Sodium penta-chloro-phenate is a white or tan, powdered solid. It is soluble in water and may burn, but it is not easily ignited. Sodium penta-chloro-phenate of approved brand and manufacture as approved by the Engineer-in-Charge shall be procured for application as biocide over stone masonry in heritage/historical buildings.

#### **24.4.2 Application**

The Sodium penta-chloro-phenate shall be applied with spray guns avoiding contact with bare skin altogether. The chemical should be diluted such that it should not be have concentration more than 3% in the solvent.

During spraying the spray gun shall be held perpendicular to the surface of the stone masonry and shall be passed over the stone masonry in a uniform sweeping motion. Different air pressures and fan adjustment shall be tried so as to obtain the best application.

#### **24.4.3 Precautions:**

Sodium penta-chloro-phenate may be toxic by ingestion, inhalation and skin absorption. Requisite safety precautions must be taken while applying this chemical. Good quality mask shall be borne by the worker to protect from chemical poisoning.

#### **24.3.4 Measurements**

Length and breadth of the treated area shall be measured correct to a cm and its area shall be calculated in square metres up to two places of decimal. No deduction is to be made for any openings in the range of 0.5 Sqm and nothing extra shall be payable for providing protective films on doors, windows etc.

No deduction shall be made for the jali work as well.

Nothing extra shall be paid for ornamental work of any nature up to a radius of 3.00 Metre.

#### **24.3.5 Rates**

The rate shall include the cost of all materials and labour/equipments involved in all the operations described above. Scaffolding, if required and provided, shall be paid for separately.

### **24.5 RULED / FLUSH POINTING ON RED SAND STONE WORK**

**24.5.0** Pointing shall be as per existing pattern or as decided by the Engineer-in-Charge. A sample patch shall be prepared for pointing and got approved from the Engineer-in-Charge. The further work shall be taken up only after the approval of the sample work by the Engineer in charge. The work executed should match exactly to the sample patch.

#### **24.5.1 Scaffolding**

For all exposed Red Sand stone work independent double scaffolding having two sets of vertical supports shall be provided. The supports shall be sound and strong tied together with horizontal pieces over which scaffolding planks shall be fixed. For all other work in building, single scaffolding shall be permitted. In such cases, the inner end of the horizontal scaffolding pole shall rest in a hole provided only in the header course for the purpose. Only one header for each pole shall be left out. Such holes for scaffolding shall, however, not to be allowed in pillars/columns having width less than one metre, or immediately near the skew backs of arches. The holes left in masonry works for scaffolding purposes shall be filled and made good before plastering.

The scaffolding material will be stacked at designated place decided by the Engineer-in-Charge and shall be removed after execution of the work and nothing extra shall be payable on this account.

The scaffolding shall be got approved from Engineer-in-Charge before start of work.

#### **24.5.2 Preparation of surface**

Joints shall be raked out as per item No. 24.1

### **24.5.3 Mortar**

Mortar should be weaker than the masonry to accommodate movement in heritage buildings to the extent possible. The mortars used in the old heritage buildings were usually lime based being water resistant and flexible. Mortar mix as specified in DSR item 3.19 shall be used for reference purpose only. It should be lime, Surkhi (50% red and 50% light yellow) and marble dust in proportion of 1:1.5: 0.5. However, efforts shall be made to duplicate original mortar mix and match the existing mortar joint.

### **24.5.4 Application and Finishing**

**24.5.4.1** The surface should be thoroughly cleaned and wet before application of the mortar. It should be ensured that adjoining stones should also be made wet so that the mortar dries slowly. If required, tarpaulin shall be used to make the surface shady during sunny weather. The mortar shall be pressed into the raked-out joints carefully with a pointing trowel, either flush, sunk or raised, according to the type of pointing required. The pointing lines shall be truly horizontal and vertical except where the joints are slanting in the existing heritage structural masonry. Lines of joints from different directions should meet neatly at the junctions instead of crossing beyond.

The mortar shall not be spread over the corner, edges or surface of the masonry. The pointing shall then be finished with the proper tool, in the manner described below:

**24.5.4.2 Flush Pointing:** The mortar shall be pressed into the joints and shall be finished off flush and level with the edges of Red Sand stone masonry, so as to give a smooth appearance. The edges shall be neatly trimmed with a trowel and straight edge.

**24.5.4.3 Ruled Pointing:** The joints shall be initially formed as for flush pointing and then while the mortar is still green, a groove of shape and size as per existing pattern or as shown in drawings or as instructed by the Engineer-in-Charge, shall be formed by running a forming tool, straight along the centre line of the joints. This operation shall be continued till a smooth and hard surface is obtained. The vertical joints shall also be finished in a similar way. The vertical lines shall make true right angles at their junctions or to the existing pattern of the heritage building true with the horizontal lines and shall not project beyond the same.

**24.5.4.4 Cut or Weather Struck Pointing:** The mortar as specified above shall first be pressed into the joints. The top of the horizontal joints shall then be neatly pressed back about 3 mm or as directed by the Engineer-in-Charge, with the pointing tool so that the joints are sloping from top to bottom. The vertical joints shall be ruled pointed. The junctions of vertical joints with the horizontal joints shall be at true right angles or to the shape of the existing heritage building structure.

**24.5.4.5** The superfluous mortar shall then be cut off from the edges of the lines and the surface of the Red Sand Stone masonry shall also be cleaned off all mortar. The finish shall be such that the pointing is to the exact size and shape required and the edges are straight, neat and clean.

### **24.5.5 Curing**

The pointing shall be kept wet for seven days. Treated area should preferably be covered/ wrapped with hessian cloth, which is kept wet for the entire curing period. During this period, it shall be suitably protected from direct sun and all damages.

### **24.5.6 Measurements:**

**24.5.6.1** Length and breadth of the area of stone work treated shall be measured correct to a cm and its area shall be calculated in square metres up to two places of decimal.

**24.5.6.2** The various types of pointing for example, struck, keyed, flush, tuck, etc. shall each be measured separately.

**24.5.6.3** For jambs, soffits, sills etc. for opening not exceeding 0.5 sqm each in area, ends of joists, beams, posts, girders, steps etc. not exceeding 0.5 sqm each in area and opening not exceeding 3 sqm each deductions and additions shall be made in the following way, in case of pointing on external face only.

- (a) No deduction shall be made for ends of joists, beams, posts etc. and openings not exceeding 0.5 sqm each, and no addition shall be made for reveals, jambs, soffits, sills, etc. of these openings.
- (b) Deductions for openings exceeding 0.5 sqm but not exceeding 3 sqm each shall be made as follows and no additions shall be made for reveals, jambs, soffits, sills, etc. for these openings.
  - (i) When both the faces of the wall are pointed with the same pointing deduction shall be made for one face only.
  - (ii) When two faces of wall are pointed with different pointings or if one face is plastered and other is pointed or plastered, deduction shall be made from the plaster or pointing on the side of frames for doors, windows, etc. on which the width of the reveal is less than that on the other side, but no deduction shall be made from the other side.
  - (iii) Where widths of reveals on both faces of wall are equal, deduction of 50% of area of opening on each face shall be made from area of pointing or plaster as the case may be.
  - (iv) For opening having door frame equal to or projecting beyond thickness of wall, full deduction for opening shall be made from each pointed face of wall.

**24.5.6.4** In case of openings of area above 3 sqm each, deduction shall be made for the openings, but jambs, soffits and sills shall be measured separately.

#### **24.5.7 Rate**

The rate shall include the cost of all materials and labour/equipments involved in all the operations described above. Raking of joints and Scaffolding if required & provided shall be paid for separately.

### **24.6 RULED / FLUSH POINTING ON WHITE SAND STONE MASONRY**

**24.6.0** Pointing shall be as per existing pattern or as decided by the Engineer-in-Charge.

#### **24.6.1 Scaffolding**

Same as 24.5.1 above.

#### **24.6.2 Preparation of surface**

Joints shall be raked out as per item No. 24.1

#### **24.6.3 Mortar**

Mortar mix as specified in DSR item 3.19 shall be used with slight variation to the contents of Surkhi. It should be lime, Surkhi (15% dark red and 85% light yellow or as approved by the Engineer in Charge) and marble dust in the proportion of 1:1.5:0.5.

#### **24.6.4 Application and Finishing**

Same as 25.5.4 above

#### **24.6.5 Curing**

Same as 25.5.5 above



**24.6.6 Measurements:**

Same as 25.5.6 above

**24.6.7 Rate**

Same as 25.5.7 above

**24.7 STONE SURFACE STRENGTHENING BY USING CHEMICALS**

**24.7.0** Deterioration of heritage/historical buildings is caused by weathering conditions like atmospheric pollution, salty water or winds and effect of pollutants from rainwater. This deterioration process can be delayed by application of chemical solvents over the surface of the stone masonry. The solvent/chemical coating enhances the compressive strength of the stone particularly sand stone. The chemical fill the pores of the stone masonry and creates a protective cover thereby preventing the absorption of the water containing harmful pollutants.

**24.7.1 Material**

The most commonly used stone surface strengthening chemical is Ethyl Silicate. Ethyl Silicate has very good compatibility with stone having silicate-based composition like Sand Stones. The chemical shall be of approved brand and manufacture. However, the choice of the chemical depends upon the prevailing climate conditions and type of stone masonry. Therefore, the chemical shall be got approved from ASI and/or Engineer- in- Charge before application.

**24.7.2 Tools and Plants**

The chemical is to be applied with simple painting brushes or with spray gun as decided by the Engineer-in-Charge.

**24.7.3 Surface Application**

A sample patch of 5 Sqm or of the size decided by the Engineer-in-Charge shall be prepared to know the number of strokes/coats required for achieving “apparent refusal” i.e. no further absorption by the stone masonry. The further work shall be taken up after approval and requisite number of coats as decided in the test patch shall be applied. The decision of the Engineer in charge shall be final and binding in this regard.

The chemical should be applied only on clean and dried stone masonry. In no case the surface should be wet before application of the chemical. As far as possible the chemical should be applied with brushes as it offers good penetration and good efficiency of the chemical application. The chemical can be applied with spray gun for sites where time is limited. Where sufficient time is available brushing offers a good methodology for application of the chemical to desired penetration. Spraying delivers high quantity of the chemical at a time causing a large runoff and lesser penetration.

The chemicals should be uniformly applied with brushes or spray on the existing stone masonry until there is “apparent refusal” i.e. no further absorption by the stone masonry. Over deposition of the chemical at a place shall be avoided altogether. After application of the first coat, second coat shall be applied once the first is dried or at least a gap of 10 minutes is to be made.

The stone masonry surface where the chemical is to be provided shall be protected from direct sun light, rain, snow or heavy winds.

**24.7.4 Measurements**

Measurements shall be same as described in para 24.1.6

**24.7.5 Rates**

The rate shall include the cost of all materials and labour/equipments involved in all the operations described above. Scaffolding if required & provided shall be paid for separately.

## **24.8 REDUCTION OF MOISTURE ABSORPTION BY STONE MASONRY BY APPLICATION OF SEALERS**

**24.8.0** Mortar and masonry tend to readily absorb water due to their pore and capillary structure. The damage to the heritage structure can be prevented by application of a water repellent sealer which reduces the absorption of the moisture by sand stone masonry or mortar.

### **24.8.1 Materials:**

Silanes and Siloxanes are the two most common type of water repellents derived from the silicone molecule. Silicone is a generic name for a wide variety of polymeric chains constructed around a molecular backbone of Silicon-oxygen-silicon.

Silanes and Siloxanes are penetrating type sealers which allow the heritage stone masonry to breathe, moisture vapour to escape while repelling water from the outside. Moreover, these do not impart any gloss to the stone masonry and there is little change to the appearance of the heritage structure.

When applied, Silane water repellents penetrate the stone masonry and react chemically with Calcium Hydroxide (CaOH) to form a hydrophobic, water repellent resin within the pores and on the surface. Silanes act only if the pH of the stone masonry is high and also must contain Calcium Hydroxide.

On the contrary Siloxanes react with atmospheric moisture as well as any moisture in the existing masonry to form the hydrophobic resin. Siloxanes are ideal for stone masonry. However, the type of chemical to be used shall be approved by ASI and/or the Engineer in Charge.

***Silanes or Siloxanes:*** Silanes and Siloxanes of approved brand and manufacture as approved by ASI and/or by the Engineer-in-Charge shall be used as per manufacturer's specifications.

***Turpentine:*** Mineral turpentine i.e. petroleum distillate which has the same rate of evaporation as vegetable turpentine (distillate product of oleoresin of conifers) shall be used. It shall have no grease or other residue when allowed to evaporate. It shall conform to IS 533. Turpentine oil recommended by the manufacturer or as approved by the Engineer-in-Charge shall be used.

### **24.8.2 Tools and Plants**

Silanes and Siloxanes can be applied with good quality of brush, roller or spray as decided by the Engineer in Charge.

### **24.8.3 Preparation of surface**

The surface of stone masonry shall be cleaned properly by using any methods decided by the Engineer-in-Charge. The surface shall be cleaned for any dirt, dust etc. by application of broom, vacuum cleaner or any other method. The surface shall be dry before application of the Silanes and Siloxanes.

### **24.8.4 Mixing of the Chemicals:**

The Silanes and Siloxanes of approved brand and manufacture shall be applied by diluting with mineral Turpentine oil in the ratio of 1:12 i.e. one part of the approved chemical and 12 parts of mineral turpentine oil. The chemicals shall be properly mixed before application in a clean container.

### **24.8.5 Surface Application**

When the stone masonry is dry the chemicals are sprayed in uniform and even layers to the required number of coats as decided by the Engineer in Charge. Each coat shall be allowed to dry for 3-4 hours before application of the next coat.



Spraying should be done only when dry condition prevails. During spraying the spray gun shall be held perpendicular to the surface to be coated and shall be passed over the stone masonry in a uniform sweeping motion. Different air pressures and fan adjustment shall be tried so as to obtain the best application. The Air pressure shall not be kept too high as otherwise the chemical will fog up and will be wasted.

At the end of the job, the spray gun shall be cleaned thoroughly so as to be free from dirt or chemical. Incorrect adjustments shall be set right, as otherwise they will result in variable spray patterns, runs, sags and uneven coats.

#### **24.8.6 Measurements**

Measurements shall be same as described in para 24.1.6

#### **24.8.7 Rates**

The rate shall include the cost of all materials and labour/equipments involved in all the operations described above. Scaffolding if required and provided shall be paid for separately.

**SUB HEAD : 25.0**

**STRUCTURAL GLAZING ALUMINIUM  
COMPOSITE PANEL**



## CONTENTS

| <i>Clause No.</i> | <i>Brief Description</i>                                       | <i>Page No.</i> |
|-------------------|--|-----------------|
| 25.1              | Materials (General)  | 1261            |
| 25.2              | Sealants & gaskets   | 1262            |
| 25.3              | Glass  | 1264            |
| 25.4              | Metal coatings   | 1265            |
| 25.5              | Standards  | 1266            |
| 25.6              | Design   | 1266            |
| 25.7              | Shop drawings  | 1266            |
| 25.8              | Documentation and certification                                | 1267            |
| 25.9              | Samples and mock-up at site                                    | 1268            |
| 25.10             | Storage, protection and programme                              | 1268            |
| 25.11             | Performance requirements                                       | 1269            |
| 25.12             | Curtain glazing and aluminium composite panel cladding systems | 1270            |
| 25.13             | Measurements   | 1272            |
| 25.14             | Rate   | 1272            |



## 25.0 STRUCTURAL GLAZING ALUMINIUM COMPOSITE PANEL

### 25.1 Materials (General)

**25.1.1** Materials and components used shall be of the first / superior quality and suitable for the purpose.

**25.1.2** All materials shall be free from any defects that may impair the strength, functioning/ performance or appearance of the curtain wall or adjacent construction.

### 25.1.3 Fasteners

**25.1.3.1** The type, size, alloy, quantity and spacing of all anchor fasteners and/or anchorage devices shall be as required for the specified performance standards.

**25.1.3.2** Bolts, anchors and other fastening devices like screws, nuts, washers etc. shall be of approved types as required for the strength of the connections, shall be self-locking, unless otherwise specified. These shall be of austenitic stainless steel of specified grade and shall be torque tightened, wherever required, to achieve the maximum torque tension relationship in the fasteners. Washers, nuts and all accessory items shall be of the same material as fasteners. The rivets/ nuts, bolts and washers for fixing insulation layer to the shadow box or with fire-stops (barriers)-cum-smoke seal shall be stainless steel of approved grade.

| Type of fasteners            | Grade of stainless steel  |
|------------------------------|---------------------------|
| Anchor fasteners             | Stainless steel grade 316 |
| Screws, Nuts, Bolts, Washers | Stainless steel grade 304 |
| Rivets, toggles and the like | Stainless steel grade 304 |

**25.1.3.3** The anchor fasteners shall not be provided using PVC sleeves. Only expandable type self locking fasteners shall be provided.

### 25.1.4 Aluminium extrusions

**25.1.4.1** In general aluminium alloy for extrusions shall be 6063 T5 or T6 grade as per B.S.1474. However, the grade and tempering specifications shall be as recommended by the supplier for each application.

**25.1.4.2** All extruded aluminium sections shall be anodized in approved colour to a minimum thickness of 20 microns or shall be PVDF coil / spray coated in approved colour and shade with metallic colours to a minimum thickness of 35 microns. The colour and the finish shall be uniform and free of streaks. The aluminium sections, before coating, shall be suitably cleaned, rinsed, buffed properly and sealed and protected after anodizing / PVDF coating, till the completion of the work.

**25.1.4.3** All surfaces of the aluminium sections designed to receive the sealants shall be finished properly to match the finish of the parent section as used for initial testing of sealant and aluminium surface adhesion. Further, it shall be ensured that the entire aluminium surface has adequate sealant contact and adhesion.

**25.1.4.4** Sill sheets, plates and extrusions shall be visually flat under all lighting conditions.

**25.1.4.5** The members of aluminium extruded sections for mullions, transoms, members of sub frames & sash frames shall be in single piece and not be splice jointed in the panel length and height.

### **25.1.5 Aluminium flashing**

**25.1.5.1** All flashings shall be made from 1.0 mm thick solid aluminium sheet transparent anodized to a minimum thickness of 10 microns. It shall be fixed using stainless steel screws dipped in weather silicone sealant.

### **25.1.6 Aluminium composite panels**

**25.1.6.1** The soffits of the canopies / walkways / entrance canopies etc., required as per the architectural drawings, shall be covered with aluminium composite panel material. The top of the canopies / walkways / entrance canopies shall be covered with zincalume sheets. The aluminium composite panel and zincalume sheets shall be bent to the required profile and fixed as per the approved shop drawings prepared on the basis of architectural drawings.

### **25.1.7 Brackets**

**25.1.7.1** The brackets shall be fixed with high degree of accuracy to achieve the elevation as per the architectural drawing. The brackets shall have suitable lengths and sections to align curtain glazing in one face, as required as per the architectural drawings. Nothing extra shall be payable on this account. The brackets shall be fabricated from M.S rolled sections / plates to have the design strength. The quality of the weld shall also be ensured as per the standards. These shall be provided corrosion protection treatment by Hot Dipped Galvanizing. The mass of the zinc coating to be not less than 610 gm. per sqm of steel area to be galvanized. Slots of elliptical or circular shape in the brackets shall be pre-drilled / machine punched and not flame cut and it shall be done before galvanizing. The surface of the brackets shall be serrated for additional grip before galvanizing. Washers made of serrated plates of the corresponding material shall also be provided for additional grip. The directions of the serration and the slot shall be such that they allow movements as per the design requirement and at the same time prevent any movement in the other direction. Each bracket shall be fixed to the R.C.C using anchor fasteners of suitable capacities and in numbers as required as per the design requirements. The brackets shall be fixed to the structural steel members of the building using stainless steel bolts & nuts / fasteners of required capacity and in numbers as per the design requirement. The holes of the required sizes shall be pre- drilled in RCC/ structural steel for fixing anchor fasteners/ bolts etc. Nothing extra shall be payable on this account.

### **25.1.8 Fittings**

**25.1.8.1** All hardware and fittings such as patch fittings, handles, locks, stay-arms, floor springs, friction stays etc. for doors , windows and open able panels shall be heavy duty and of approved make as specified.

**25.1.8.2** Hinges for open able panels shall be heavy duty top hung stainless steel friction hinges selected for specified wind load and dead loads.

**25.1.8.3** All fittings and locks shall be as specified.

**25.1.8.4** Each open able panel of the Curtain glazing shall be provided with the fittings as specified in item nomenclature.

## **25.2 SEALANTS & GASKETS**

### **25.2.1 Selection of sealants**

**25.2.1.1** The compatibility and sequence of installation for all sealants must be carefully considered in all proposals in order to ensure the required curing and performance.

**25.2.1.2** Sealants must not degrade and / or fail under any or all design conditions including wind, thermal and seismic movements, exposure to water and humidity, ultraviolet exposure and / or other adverse environmental conditions.

**25.2.1.3** The designations of sealant types specified herein are intended for general design guidance only.

**25.2.1.4** Final selection for the sealant types shall be based on their conformity with the Performance Requirements specified herein and as per the recommendations of the sealant manufacturer. It may use sealant of equivalent grade and characteristics, manufactured by the manufacturer other than those specified herein, based on recommendations of those sealant manufacturers for specified use but with the prior approval of the Engineer-in-Charge. The contractor shall submit the documentary evidence in this regard.

**25.2.1.5** All precautions shall be taken during design of structural silicone bite and also during fabrication of the curtain glazing system to prevent failure of sealant during the guarantee period of 10 years after the date of completion of work and even beyond, upto the expected service life of the curtain wall.

**25.2.1.6** Sealants and gaskets shall not leach, discolour, stain or dry.

### **25.2.2 Structural silicone sealant**

**25.2.2.1** The sealant manufacturer shall design the silicone bite for the design loads as specified and likely to come during the life of the curtain glazing system for arriving at bite size of the structural silicone sealant.

**25.2.2.2** The structural silicone sealant bite as designed by the sealant manufacturer and as per the approved shop drawings shall be provided.

**25.2.2.3** The Structural sealant shall be two part pump-filled Silicone sealant DC 983 of Dow Corning or equivalent recommended by manufacturer. The weather silicone sealant shall be one-part Silicone sealant DC 795 of Dow Corning or equivalent of other approved brand as per the list of approved materials.

**25.2.2.4** The structural sealant to be used as specified for all exposed and concealed metal to metal (including tight or butt type metal to metal assembly prior to assembly) or glass to glass shall be 2-part silicone sealant, conforming to the manufacturer's recommendations for the specific uses and performance criteria. The sealant shall be applied using two-part pump for the same. All the sealing shall be done in a clean and controlled environment as specified by the silicone sealant manufacturer.

### **25.2.3 Weather silicone sealant**

**25.2.3.1** The grade of weather silicone sealants wherever required like for concealed metal to metal, metal to glass and metal to concrete/ masonry such as embedment and lapping of flashings etc. where elements are to be installed or embedded, the weather sealant shall be of grade 795 of Dow Corning or equivalent for the other approved brand, as per the recommendations of the sealant manufacturers. Also, the gap between the aluminum sections and the glass, if so required, shall be filled with weather sealant as specified above including providing and fixing backer rod wherever required as per the approved shop drawings. The weather silicone sealant shall be of approved colour and shade. The weather silicone sealant for fixing the butt jointed glass for the fixed partitions shall be transparent in colour DC 791 of Dow Corning or equivalent of other approved brands.

### **25.2.4 Compatibility**

**25.2.4.1** All sealants must be non-staining and compatible with adjoining sealants, backup materials, substrate materials and their respective finishes and/or applied colour coatings. Care shall be taken to ensure that two different types of sealant should not come in contact with each other unless compatibility is satisfied as per manufacturer's specifications.



### **25.2.5 Caulking compound**

**25.2.5.1** Dow Corning weather silicone sealant – 795 or equivalent as approved by the Engineer-in-Charge, ( of approved colour and shade to match adjacent material wherever exposed and visible) for use around frame/ flashings or between frame/flashing and RCC/ masonry surface.

### **25.2.6 Gaskets**

**25.2.6.1** Gaskets and seals shall be of approved quality compatible with substrates, finishes and other components they are in contact with. All gaskets exposed directly on the exterior face shall be silicon gaskets, which are UV resistant. They shall not degenerate, discolour or leach on exposure to solar radiations/ rains/ pollutants etc.

**25.2.6.2** Manufacturers' test Certificate shall be submitted as specified.

## **25.3 GLASS**

### **25.3.1 General**

**25.3.1.1** All glass and glazing materials shall be as specified.

**25.3.1.2** Vision and spandrel glass shall have characteristics as specified.

**The performance characteristics of glass panels**, have to be ensured within the constraints of aesthetic requirements like colour, shade, reflectivity etc. And performance requirements like light transmission, U value, shading coefficient, relative heat gain etc. as specified. Minor variations in the characteristics of glass on superior side may be allowed, but without any extra cost to the Department on this account.

### **25.3.2 Installation**

**25.3.2.1** Install glass panels and carry out glazing work as indicated on the drawings and as specified herein.

**25.3.2.2** All glass panels shall be of accurate sizes as required.

**25.3.2.3** All glass panels shall have clear undamaged edges and surfaces, which are not disfigured.

**25.3.2.4** Any glass panel that does not fit in the curtain glazing system shall be rejected. Therefore, all care and precautions shall be taken while procuring the glass panels from the manufacturer / processors of the glass. No claims of any kind or any hindrance shall be entertained from the contractor on this account.

**25.3.2.5** Glass panels shall not be in direct contact with the aluminum framework.

### **25.3.3 Identification**

**25.3.3.1** Permanent identification marking on glass shall be accomplished by a technique selected by the manufacturer. The location of the marking shall be proposed by the Manufacturer and approved by the Engineer – in - Charge. All glass shall be delivered to site with the manufacturer's / processor's label of identification attached.

### **25.3.4 Selection of Glass**

**25.3.4.1** Each type of glass shall be obtained from only one manufacturer and preferably in one lot.

### **25.3.5 Insulated Glazed Units (IGUs) in the vision panels**

**25.3.5.1** Insulated glazed units shall be obtained only from approved manufacturers/ processors as per the approved list.

**25.3.5.2** Insulated units shall be factory assembled, with multiple panes, hermetically sealed, separated by and sealed to spacer tubes perforated on inner exposed face forming airtight dehydrated airspace inside the insulated units. The IGUs shall be assembled (prepared) by the manufacturer/ processor of the glass as per the approved list, in their dedicated workshops/ factory.

### **25.3.6 Laminating units**

**25.3.6.1** The glasses shall be laminated with interlayer of Polyvinyl butyral (PVB) sheet of specified thickness

**25.3.6.2** The interlayer material (PVB) shall be clear or as specified with no tendency to bubble, discolour or lose physical and mechanical properties after laminating glasses.

**25.3.6.3** The laminated panels shall be free of foreign substances, air or glass pockets and shall not delaminate at edges.

### **25.3.7 Precaution in storing and handling glasses**

**25.3.7.1** The glass manufacturer/ processor shall take necessary precautions as stated below besides any other precautions not specifically mentioned herein:

**25.3.7.1.1** The reflective/ low E coating on the glass shall be protected against scratches, surface corrosion, staining and/ or any other abrasion.

**25.3.7.1.2** The glasses shall not be stored without a clean inter-leaving material. Also they should not slide against each other.

**25.3.7.1.3** The glass shall be protected from weld or grinding splatter.

**25.3.7.1.4** The reflective/ low E coating shall be protected against contact with acids or strong alkalies. The cleaners to be used for cleaning the surface shall be as per the manufacturer's recommendations. The glass shall be protected against moisture from humidity, which can stain glass as well as coating.

**25.3.7.1.5** Reflective/ low E coating shall also be protected against splashes from paints etc.

## **25.4 METAL COATINGS**

### **25.4.1 Anodizing / PVDF coating**

**25.4.1.1** Aluminium extruded sections shall be satin finish colour anodized to minimum 20 microns thickness, as per the approved colour and shade or PVDF coil / spray coated to approved metallic colour and shade to minimum 35 microns thickness.

### **25.4.2 Galvanizing**

**25.4.2.1** The brackets for the curtain glazing system shall be hot dipped galvanized. The mass of the zinc coating to be not less than 610 gm. per sqm of steel area to be galvanized.

### **25.4.3 Samples**

**25.4.3.1** Three samples shall be prepared, which shall define the colour and gloss of anodizing and submit them for approval.

#### **25.4.4 Matching of finish**

**25.4.4.1** Wherever the same colour finish is specified for extruded aluminium sections and composite aluminium sheets. It shall be ensured that the colour of both is matched as closely as possible.

#### **25.5 STANDARDS**

**25.5.1** In general, it shall be followed either of the latest Indian/ International Standards as applicable for this sub head.

#### **25.6 DESIGN**

**25.6.1** Architectural drawings and specifications only indicate the required basic dimensions, and performance criteria.

**25.6.2** It shall be ensured that proper structural analysis and design for various load cases and their combination. This shall include designing and proper sizing of all sections meeting structural and architectural requirements. The anchor assemblies shall meet the performance and design requirements including installation of all inserts, fasteners, clips, bracing and framework as required for the proper anchorage to the structure, unless otherwise specified.

**25.6.3** Design of the curtain glazing system shall comply with all Government codes and regulations. The Contractor shall design the entire curtain glazing system for dead loads, wind loads, seismic loads, storm, air pollution, thermal stresses, building movements and consequent deflections without compromising the performance characteristic. Further, the individual members of the structural framing shall not deflect beyond permissible limits as specified. The design shall comply with the requirements of the relevant National Building Code and Indian Standard Code/ International Standards, unless specified otherwise.

**25.6.4** The curtain glazing system and its elements shall not sustain permanent deformation or failure under loading equivalent to 1.5 times the design wind pressure.

**25.6.5** The specified deflections must be reduced if they are in any way detrimental to curtain glazing system and building.

**25.6.7** It shall be ensured that the elevations are strictly as per the architectural drawings and that the intent of the architectural design is retained. Visual appearance shall be a key consideration for acceptance of work.

#### **25.7 SHOP DRAWINGS**

##### **25.7.1 Submittals**

**25.7.1.1** The contractor shall prepare shop drawings based on approved design and submit the same to the Engineer –in-charge for approval.

**25.7.1.2** The review of the shop drawings shall be limited to their conformity to the architectural and structural design concept & specifications.

**25.7.1.3** No fabrication shall be taken up until the shop drawings and all other related submittals, documentation, certification, samples and the mock-up for that work have been reviewed and approved by the Engineer-in-charge.

##### **25.7.2 Scope of shop drawings**

**25.7.2.1** Shop drawings shall incorporate scaled and dimensioned plans, elevations, sections and complete size details for all the works.

**25.7.2.2** The shop drawings shall indicate the required dimensional profiles and modules, function, design and performance standards and in general cover all dimensions and details required to fabricate and install the curtain glazing system.

**25.7.2.3** The contractor shall verify and co-ordinate the shop drawings with all applicable and inter-related trades, drawings and specifications.

**25.7.2.4** All dimensions / modules, etc., shall be field checked and the drawings shall be modified, if required, based on actual measurements at site.

**25.7.2.5** Details shall show and specify all metal sections, types of finishes, areas to be sealed and sealant materials, gaskets, applicable construction materials including fasteners and welds, all anchorage assemblies and components, fabrication and erection tolerances for the work.

**25.7.2.6** All details shall be subject to the approval of the Engineer-in-Charge, after incorporating all the modifications suggested by the Engineer-in-Charge.

### **25.7.3 Section profiles**

**25.7.3.1** Profile adjustments, if required as per the site conditions may be allowed by the Engineer-in-Charge subject to meeting the architectural / performance requirements. However, this shall be carried out only with the written approval of the Engineer-in-charge provided that the general design and intent of the drawings and specifications are also maintained. Also, if any new / non-standard aluminium extruded section is required as per the site requirement and / or the architectural drawings for functional and / or aesthetic reasons, the contractor shall procure the same from the approved manufacturers for the aluminium sections, even if it entails preparing new die, etc. Nothing extra shall be payable on this account.

## **25.8 DOCUMENTATION AND CERTIFICATION**

**25.8.1** The manufacturer's certificate for compliance of the various components/ materials for the works (under this sub head) as per the manufacturer's specifications for the various characteristics. A copy of the manufacturer's test report for each lot of material procured and supplied for the work shall also be obtained from the respective manufacturers and submitted to the Engineer-in-Charge for the record.

### **25.8.1.1 Glass and glazing documentation**

**25.8.1.1.1** Before taking up the work, the glass manufacturer / processor shall submit written certification for the review of the Engineer-in-Charge and record, stating that all glass (properties as specified such as U value, shading coefficient, light transmission, solar factor, relative heat gain etc.) and glazing requirements (including heat strengthening/ toughening, reflective soft coating, low E coating, lamination, fabrication of IGUs including sealants) as per the shop drawings are recommended by them for use related to their specific applications and design parameters and that they are in conformity with the specifications.

**25.8.1.1.2** Tests shall be carried out for glass, including properties after processing, for each lot supplied, by the glass manufacturer / processor in his factory /laboratory or any other accredited laboratory and the copies of the test results shall be obtained by the contractor and submitted to the Engineer-in-Charge for the record.

### **25.8.1.2 Sealant Documentation**

**25.8.1.2.1** All sealant applications must be clearly designated on shop drawings.

### **25.8.1.3 Quality control documentation**

**25.8.1.3.1** The methodology and quality assurance statement shall be submitted for quality control procedures for the review and approval of the Engineer-in-Charge before taking up the work to ensure the design integrity and performance of the curtain glazing, aluminium composite panel cladding and aluminium work (PVDF coated).

**25.8.1.3.2** The Engineer-in-Charge or his authorized representatives may visit the plant / workshop / factory to inspect material, fabrication and quality assurance procedures.

## **25.9 SAMPLES AND MOCK-UP AT SITE**

### **25.9.1 Submittals**

The samples of the following materials together with detailed technical data / catalogues shall be submitted for review and approval of the Engineer-in-Charge along with the shop drawings..

**25.9.1.1** Aluminium Composite Panel : Each type and thickness 600mmx600mm

**25.9.1.2** Aluminium extrusions : Each section: 500mm long.

**25.9.1.3** Glass : Each type 600 mm x 600 mm.

**25.9.1.4** Gaskets, separators, glass setting blocks / spacer tape, etc : Each section or unit, backer rods, 300mm long or unit.

**25.9.1.5** Bracket, fasteners and Connecting devices : Each type and size.

**25.9.1.6** Finish samples : After approval of the final finish coating, the Engineer-in-Charge shall be provided with three (3) approved samples.

**25.9.1.7** Ironmongery and accessories, as applicable.

**25.9.1.8** Finished flashing samples

**25.9.1.9** Finished samples of shadow boxes, fire stop (barrier)-cum smoke seals

**25.9.1.10** Structural and weather silicone sealant

### **25.9.2. Mock-up at site**

Before the fabrication and site installation is taken up and after the approval of shop drawings by the Engineer-in-Charge, a mock-up shall be prepared of his proposed curtain glazing system for a size of panel not exceeding 6 sqm. The mock-up shall be essentially put up at site for final approval of all materials and installation details by the Engineer-in-Charge. The mock up shall not form part of the work and shall not be paid for. It shall be dismantled and taken away by the contractor at his own cost, with the prior permission of the Engineer-in-Charge. Nothing extra shall be payable on this account.

## **25.10 STORAGE, PROTECTION AND PROGRAMME**

**25.10.1** A schedule of procedure shall be submitted for inspection during installation so as to control and assure quality on the job site.

**25.10.2** A detailed method statement shall be submitted for the protection of the surface of the curtain glazing, aluminium composite panel cladding and aluminium work (PVDF coated), etc during delivery and erection, with description as to when the protection can be removed. The protection paper shall be kept for a period as recommended by Engineer-in-Charge and shall be replaced with the fresh protection paper, if so required. Further, it shall not have acid content, which in any manner may affect the substrate.

**25.10.3 Delivery and Storage of Materials:** All materials delivered to site shall be stored in allocated spaces where the stored materials shall not get exposed to rainwater, moisture or damage, and shall permit easy access to and handling of the materials. Materials shall be stored neatly and properly stacked.

**25.10.3.1** Factory made glazing units and/or their components shall be transported, handled and stored in a manner to preclude damage of any nature.

**25.10.3.2** Necessary materials, required for erection at the site shall be delivered in labeled containers by the manufacturer / supplier.

**25.10.3.3** All units or components, which are cracked, bent, chipped, scratched or otherwise defective and unsuitable for installation shall be removed and replaced by the contractor. Nothing extra shall be payable on this account.

## **25.11 PERFORMANCE REQUIREMENTS**

All components, assemblies and completed work shall conform to the various performance standards as applicable in respect of thermal movement of the curtain glazing, allowance for vertical and horizontal expansion and building movement and related building tolerance etc. The design and installation of the curtain glazing system shall accommodate all inherent building movements and deflections and the fabrication and installation tolerances of all related work not involved in this section without the loss of, or any detrimental effect to, the performance requirements herein specified. The contractor shall verify and coordinate all such movements and tolerances with the Engineer-in-Charge before designing the components of the curtain glazing system so that movements and deflections in the structure do not at any time affect the integrity and safety of curtain glazing system and vice versa.

### **25.11.1 Thermal property**

**25.11.1.1** All insulation materials, fire-stops (barriers)-cum-smoke seal shall comply with the current requirements of the Fire Officer, MIDC and other authorities.

### **25.11.2 Structural properties**

**25.11.2.1** The curtain glazing system shall be anchored to the R.C.C floor through serrated Hot Dipped Galvanized M.S brackets. As far as possible, the contractor shall take all precautions to avoid cutting through any reinforcement bars while fixing the brackets. The cost includes provision of sleeves/ leave slots at appropriate locations during casting of the concrete itself for making provision for fixing brackets for the curtain glazing system and to avoid chipping/ dismantling of concrete. The slot shall be filled up with concrete of the same grade in a workman like manner, after fixing the brackets. Any defect in alignment/ plumb in the building face shall be rectified by chipping/ dismantling of the concrete/ masonry and repairing the same as specified to achieve the required alignment of the curtain wall as specified. Any change in lengths of bracket/s required on this account and the consequent requirement of their sections and sizes shall be carried out. Nothing extra shall be payable on this account.

**25.11.2.2** No holes shall be burned, filed or drilled in any structural steel/ RCC members unless expressly approved by the Engineer – in – Charge.

**25.11.2.3** Member shapes and/or profiles if schematically shown on the Architectural drawings are not necessarily the exact shapes required or best suited for the particular conditions. Final shapes and locations shall be as designed by the contractor and are subject to the review and approval of the Engineer – in – Charge.

**25.11.2.4** All framing members shall be shop fabricated and finished as specified.



### **25.11.3 Concrete tolerances**

**25.11.3.1** While fixing the brackets for curtain glazing system, the contractor shall take into account the variation in the concrete and the masonry faces to which the structural framework of the curtain glazing system is to be fixed and such variations shall be adjusted in the lengths of brackets to align them in perfect plumb. The bracket shall be designed accordingly. Nothing extra shall be payable on this account.

### **25.11.4 Fire stops (barriers)-cum-smoke seal and interface with building**

**25.11.4.1** Gaps between the building face and the curtain glazing system at soffit level between the successive floors shall be closed as specified with fire-stops (barriers)-cum-smoke seal. It shall have the required fire resistance to be approved by Fire Officer. Suitable gap for accommodating deflections of the aluminium framing of curtain glazing system as per the approved shop drawings shall be maintained between the fire-stops (barriers)-cum-smoke seal and the curtain glazing system. This smoke seal shall however be provided using backer rod and weather silicone sealant as specified and as approved by the Engineer-in-Charge.

**25.11.4.2** The fire-stops (barriers)-cum-smoke seal shall consist of 1 mm thick plain G.I. sheet tray with 100 mm thick layer of non inflammable heat insulating material, rock wool, having density of minimum 64 Kg. per Cum. of the make as approved by the Engineer-in-Charge. The rock wool layer shall be attached to G.I sheet using stainless steel rivets/ nuts, bolts and washers. The tray shall be fixed to the RCC / Masonry surface by using stainless steel screws dipped in weather silicone sealant as per the approved shop drawings. Screws with plastic sleeves shall not be allowed to be used for the above fixing.

**25.11.4.3** An aluminium flashing of 1.0 mm thick shall be permitted transparent anodized (10 micron thickness) solid aluminium sheet of the approved design and profile at the window sill level and also fill the gap between the aluminum flashing and the curtain glazing using weather silicone sealant as specified and as approved by the Engineer-in-Charge. Also, the fasteners/ screws to be used for fixing flashing shall be dipped in weather silicone sealant before using.

### **25.11.5 Acoustics**

**25.11.5.1** Gaps between the mullions and the partitions of the cabins shall be suitably closed by double skin partition as directed by the Engineer-in-Charge including allowing for permissible deflections of mullions as per design requirements but without affecting the partitions and the curtain glazing system. The payment for this partition work shall be made under relevant item.

**25.11.5.2** Provisions shall also be made to prevent metal to metal rubbing, any rattling, noise due to thermal changes and wind pressure by using Teflon separators and shims.

### **25.11.6 Visual appearance**

**25.11.6.1** It shall be ensured that the elevations are strictly as per the Architectural drawings and that the intent of the architectural design is retained. Visual appearance shall be a key consideration for acceptance of work.

## **25.12 CURTAIN GLAZING AND ALUMINIUM COMPOSITE PANEL CLADDING SYSTEMS**

### **25.12.1 General**

**25.12.1.1** Movement of building components to which the curtain glazing system is attached including long term and short term movements due to thermal effect, structural effect, wind pressure, seismic forces, erection or dead loads, creep, column shortening, deflection, torsion and vibrations etc shall be free and noiseless. This shall be achieved without any strain or stress being transferred to the glass, without buckling of any components, without excessive stress to any members or assemblies and without compromising on any of the performance requirement of the curtain wall.

## **25.12.2 Waterproofing**

**25.12.2.1** Following precautions shall be taken by the contractor to ensure that the curtain glazing system is completely water tight during its guarantee period as well as expected service life besides any other precautions not specifically mentioned herein:

**25.12.2.1.1** A drainage system must be incorporated into the curtain glazing system. The curtain glazing system shall have provision for air pressure equalization (all the internal spaces shall be vented by acceptable means to ensure air pressure equalization ) so that water leakage and condensation, if any shall be drained or discharged to exterior face of the curtain glazing.

**25.12.2.1.2** Care should be taken that the sections of the aluminum extrusions used for structural framing of curtain glazing provide for proper drainage of water that in-filters into the system by gravity and for this the section should have proper slope and weep holes as required. These shall be clearly indicated on the shop drawings.

**25.12.2.1.3** Movement of water on exposed faces must be controlled to ensure that water is not retained and that elements will not be damaged or corroded by water and to minimize the potential for algae and fungal growth as a result of standing or trapped water.

**25.12.2.1.4** EPDM gaskets of the quality as specified and of required size and thickness shall be provided at all required locations to prevent ingress of water or moisture. The same shall be indicated on the shop drawings also.

**25.12.2.1.5** EPDM gaskets of the quality as specified and of required size and thickness shall be provided at all required locations to prevent ingress of water or moisture. The same shall be indicated on the shop drawings also.

**25.12.2.1.6** Aluminium sheet flashing using 1.0mm thick transparent anodized (10 microns) aluminium sheet wherever required shall be provided including sealing the gap between the flashing and the other material like RCC, masonry, aluminium etc. by using weather silicone sealant as specified.

## **25.12.3 Mullions and transoms**

**25.12.3.1** The sections of mullions and transoms shall be designed to restrict deflection under dead loads, wind load, seismic loads etc. as specified and shall be rigid and stable enough to support and retain the in-fill panels in position under all conditions. The mullions and transoms shall also be designed for additional horizontal loads from the cleaning equipment and process besides horizontal live loads as specified.

## **25.12.4 Spandrel units**

**25.12.4.1** Spandrel shall be of glass having same colour matching with vision areas after using a shadow box as specified.

**25.12.4.2** Structural spandrel wall, fins, slab or beam, aluminium frame work, anchor fasteners, brackets, shadow boxes, fire stop(barrier)-cum-smoke seals and other construction shall not be visible through the glass in the spandrel portion of the curtain glazing from the exterior and shall be fully concealed behind the shadow box.

**25.12.4.3** A shadow box shall be provided at a distance of minimum 50 mm behind the spandrel glass panel to ensure that the insulation panel material does not come in contact with the soft coating of the spandrel glass to prevent any damage to the coating on account of any chemical reaction or otherwise. It shall consist of an approved black fibre glass non-woven tissue stuck on surface #1 of



50 mm thick semi-rigid fibre glass wool insulation panel of minimum density of 48 kg per cum., and 1.5 mm thick transparent anodized (10 microns) solid aluminium sheet tray, on surface #2 by using suitable stainless steel rivets/ nuts, bolts and washers to hold the insulation panel in position. The periphery shall be properly sealed. Surface #1 shall be adequately protected against damage until spandrel glazing is done. Further, care shall be taken that the aluminium sheet backing of the shadow box does not heave or warp due to thermal stresses and/or its self-weight. Proper gaps at the edges of the tray shall be provided to accommodate movements on account of thermal stresses besides making elliptical slots if required to facilitate movements. The shadow box shall be fixed to the structural framing of the curtain glazing by using stainless steel screws. The fixing arrangement shall be as per the approved shop drawings.

### **25.12.5 Ventilators, open able windows and doors**

**25.12.5.1** Ventilators, openable windows and doors shall be provided at positions as shown on the architectural drawings. The openable panels when in closed position shall remain watertight under all weather conditions and pass the water tightness tests as specified. Besides, the openable panels shall appear similar to the fixed ones from outside.

**25.12.5.2** All hardware and accessories shall be provided and fixed by the contractor and shall be as specified.

### **25.12.6 Coping and soffit trimmer**

**25.12.6.1** All coping and soffit panels shall have aluminium structural frame fixed rigidly to the structure.

**25.12.6.2** Effective drainage system shall be provided to drain out the water that may penetrate through the joints, on to the exterior face of the curtain glazing.

**25.12.6.3** Coping and soffits shall be visibly flat in all lighting conditions.

## **25.13 MEASUREMENTS**

All the aluminium sections including snap beadings fixed in place shall be measured in running meter along the outer periphery of composite section correct to a millimeter. The weight calculated on the basis of actual average (average of five samples) weight of composite section in kilogram correct to the second place of decimal shall be taken for payment (weight shall be taken after anodizing). The weight of cleat shall be added for payment. Neither any deduction nor anything extra shall be paid for skew cuts

The height and width of double glazed/single glazed unit (the area of glass unit outside the snap beading shall only be measured) as fixed in place shall be measured correct to one centimeter and area calculated in sqm. correct to second place of decimal shall be taken for payment.

## **25.14. RATE**

**25.14.1.** Rate shall includes cost of all inputs of labour, materials including wastages, T &P, equipments, other enabling temporary structures and services and all other incidental charges, if any, not specifically mentioned here, but as required for complete design, proof checking, engineering, fabrication, assembling, delivery, anchorage, installation, protection of curtain glazing, aluminium composite panel cladding and aluminium work (PVDF coated), etc. and making the system water tight (wherever specified), all complete, all in accordance with the true intent and meaning of the specifications and the drawings taken together, regardless of whether the same may or may not be particularly shown on the drawings and / or described in the specifications , provided that the same can be reasonably inferred there from. The curtain glazing, aluminium composite panel cladding and

aluminium work (PVDF coated) shall have framing which shall be structurally and mechanically designed to achieve the architectural elevations as well as performance parameters specified herein. Anchorage shall include all supporting brackets & anchor fasteners, as required to rigidly secure the structural framing to the RCC / Masonry / structural steel members of the building.

**25.14.2.** The curtain glazing, aluminium composite panel cladding and aluminium work (PVDF coated), etc. work shall include but will not necessarily be limited to the following:

**25.14.2.1** Frames, fixed glazed / vision panels, spandrels, hard wares, open able panels, as in the drawings inclusive of all accessories and fittings. Glass wool Insulation panel (shadow box), fire stop (barrier) - cum - smoke seals, splice plates, connectors, sleeves, anti-buckling clips etc.

**25.14.2.2** Anodized aluminium work for framing of curtain glazing as well as other aluminium work (PVDF coated) for trellis, louvers, fins, box sections, capping, strip etc wherever indicated in the schedule of quantities and drawings. Glazes doors.

**25.14.2.3** Structural, weather and other silicone sealants within and all round the perimeter of all the work under this sub head for fabricating IGUs, holding the glass to the aluminium & glass to glass and to provide water tightness to the curtain glazing.

**25.14.2.4** EPDM / silicone gaskets, trims, shims, setting blocks, double sided spacer tape, spacer blocks, weathering strips etc.

**25.14.2.5** All sealing and flashings including sealing at junctions with the building members.

**25.14.2.6** All brackets, anchor fasteners, screws, inserts, nuts, bolts & washers, and attachments required for complete installation and fixing to the RCC, masonry and/or the structural steel members of the building.

**25.14.2.7** All accessories, fasteners, screws, nuts and bolts, toggles, rivets etc. and other items implied in the drawings and the specifications though are not specifically indicated.

**25.14.2.8** Isolation of all dissimilar metal surfaces as well as moving surfaces by use of TEFLON (PTFE) separators.

**25.14.2.9** Engineering proposals, design, drawings and Architectural data.

**25.14.2.10** Shop drawings, engineering data and structural calculations (analysis & design) of all systems including aluminium structural framing, fasteners, sealants etc.

**25.14.2.11** Scheduling and monitoring of the work.

**25.14.2.12** Cost of all samples of the individual components, mock-ups at site and field tests.

**25.14.2.13** Coordination with work of other agencies.

**25.14.2.14** Protection during storage and construction until handing over the building for occupation etc.

**25.14.2.15** All final exterior and interior cleaning of the curtain glazing, aluminium composite panel cladding and aluminium work (PVDF coated) etc. Before handing over the building for occupation.

---

SUB HEAD 25.0 : STRUCTURAL GLAZING ALUMINIUM COMPOSITE PANEL

**25.14.2.16** Hoisting, staging, scaffolding and temporary enabling structural work/services, cranes and cradles etc.

**25.14.2.17** Specified tests, inclusive of necessary records, reports, logbook etc.

**25.14.2.18** Design and performance guarantee in the enclosed format.

**25.14.2.19** Construction monitoring for regular quality control and technical inspection to ensure the work conforms to the approved shop drawings and details (including any modifications made after field testing) and acceptable standards of quality including monitoring the progress of the work.

**SUB HEAD : 26.0**

**NEW TECHNOLOGIES & MATERIALS**



## CONTENTS

| <i>Clause No.</i> | <i>Brief Description</i>   | <i>Page No.</i> |
|-------------------|--|-----------------|
|                   | List of Bureau of Indian Standards Codes   | 1281            |
| 26.1              | Phenol Bonded Bamboowood Flooring  | 1282            |
| 26.2              | Phenol Bonded Bamboo Wood In Wall Skirting   | 1284            |
| 26.3              | Phenol Bonded Bamboowood Wall Cladding   | 1285            |
| 26.4              | Phenol Bonded Bamboowood Panelled Or Panelled And Glazed Shutters For Doors Windows, Clerestorey Windows | 1286            |
| 26.5              | Phenol Bonded Bamboo Wood Paneling   | 1287            |
| 26.6              | Factory Made Door Frame Of Phenol Bonded Bamboowood  | 1289            |
| 26.7              | Bamboo Mat Corrugated Sheet (BMCS)   | 1290            |
| 26.8              | Phenol Bonded Bamboo Mat Board For False Ceiling   | 1292            |
| 26.9              | Bamboo Mat Board For Partition To Frame  | 1292            |
| 26.10             | Wall Panelling With Phenol Bonded Bamboo Mat Board   | 1293            |
| 26.11             | Extruded Polystyrene Rigid Insulation Board  | 1296            |
| 26.12             | Under Deck Insulation System   | 1297            |
| 26.13             | Factory Made Solid Foam Upvc Profile For Kitchen Cabinet Frame And Shutter/Partition                     | 1298            |
| 26.14             | Reinforced Soil Retaining Walls Using Geogrids   | 1302            |
| 26.15             | Aluminum Profile Industrial Troughed Sheet Roofing   | 1311            |
| 26.16             | Calcium Silicate False Ceiling (Tegular Edged)   | 1313            |
| 26.17             | Calcium Silicate False Ceiling (Micro-Edged)   | 1315            |
| 26.18             | Calcium Silicate Wall Paneling (Fully Perforated Square/ Butt Edged)                                     | 1317            |

|       |  |      |
|-------|--|------|
| 26.19 | Calcium Silicate False Ceiling (Tegular Edged-Fixed To Existing T-Frame)                                 | 1319 |
| 26.20 | Glass Fibre Reinforced Gypsum (GRG) False Ceiling (Semi Perforated Micro Tegular Edged)                  | 1321 |
| 26.21 | Glass Fibre Reinforced Gypsum (GRG) False Ceiling (Fully Perforated Micro Tegular Edged)                 | 1323 |
| 26.22 | Mineral Fibre False Ceiling (Beveled Tegular Mineral Fibres)   | 1324 |
| 26.23 | Mineral Fibre False Ceiling (Beveled Tegular Mineral Fibre Anti-Microbial)                               | 1326 |
| 26.24 | Chipping Of Unsound / Weak Concrete:   | 1326 |
| 26.25 | Cleaning Of Existing Reinforcement And Passivating Its Surface   | 1326 |
| 26.26 | Drilling Suitable Holes In RCC Or Plain Cement Concrete  | 1327 |
| 26.27 | Bonding Coat:  | 1327 |
| 26.28 | Providing, Mixing And Applying SBR Polymer Modified Cement Mortar  | 1328 |
| 26.29 | Applying SBR Polymer Modified Cement Concrete For Structural Members                                     | 1328 |
| 26.30 | Providing And Injecting Grout  | 1329 |
| 26.31 | Protective Fabric Screens  | 1330 |
| 26.32 | Cleaning Of Exposed Concrete Surface By Sand Blasting  | 1330 |
| 26.33 | Shotcreting  | 1331 |
| 26.34 | Providing And Inserting Galvanized Steel Injection Nipple  | 1331 |
| 26.35 | Providing & Fixing Hard Drawn Steel Wire Fabric  | 1332 |
| 26.36 | Light Gauge Steel Framed Structure (LGSFS)   | 1332 |
| 26.37 | External Wall System On Light Gauge Steel Frame Work With Outer Face Having 6mm Thick Fiber Cement Board | 1333 |

|                             |  |      |
|-----------------------------|--|------|
| 26.38                       | Internal Wall Panels On Light Gauge Steel Frame Work With 12.5mm Thick Gypsum Plaster Board    | 1335 |
| 26.39                       | Exterior Face Panels Breathable Vapour Barrier Underneath The Cement Fiber Board               | 1336 |
| 26.40                       | Moisture Resistant/Fire Resistant 6 mm Thick Fiber Cement Board                                | 1337 |
| 26.41                       | Glass Fibre Reinforced Gypsum (GFRG) Panel   | 1337 |
| 26.42                       | Galvanized Steel Deck Sheet Roofing Covered With Concrete                                      | 1343 |
| 26.43                       | Precast Concrete Solid Block   | 1344 |
| 26.44                       | Precast Technology   | 1351 |
| 26.45                       | Scaffolding Net  | 1358 |
| Fig. 26.1, 26.2 & 26.3      | Bamboo Mat Corrugated Sheet (BMCS)   | 1359 |
| Fig. 26.4, 26.5 & 26.6      | Bamboo Mat Corrugated Sheet (BMCS)   | 1360 |
| Fig. 26.7                   | Bamboo Mat Corrugated Sheet (BMCS)   | 1361 |
| Fig. 26.8                   | Cavity Wall Thermal Insulation System With Rigid Foam Insulation                               | 1361 |
| Fig. 26.9                   | Under Deck Insulation System   | 1362 |
| Fig. 26.10<br>26.11 & 26.12 | Geogrids   | 1363 |
| Fig. 26.13 A & 26.13 B      | Aluminum Profile Industrial Troughed Sheet - Self- Drilling Fasteners                          | 1363 |
| Fig. 26.14                  | Galvanized Steel Deck Sheet  | 1364 |
| Fig. 26.15                  | Shear Connectors   | 1365 |
| Fig. 26.16                  | Ecofriendly Light Weight Calcium Silicate False ceiling (Micro Look Edge)                      | 1366 |
| Fig. 26.17                  | Ecofriendly Light Weight Calcium Silicate Wall Panelling (fully Perforated Square/ Butt Edged) | 1367 |





### LIST OF BUREAU OF INDIAN STANDARD CODES

| <i>S. No.</i> | <i>BIS. No.</i> | <i>Subject</i>  |
|---------------|-----------------|---|
| 1             | IS 277-1992     | Galvanized Steel Sheets (Plain And Corrugated)-Specification  |
| 2             | IS 737          | Wrought aluminium and aluminium alloy sheet and strip for general engineering purposes-Specification                                      |
| 3             | IS : 801-1975   | Code of Practice for Use of Cold Formed Light Gauge Steel Structural Members In General Building Construction                             |
| 4             | IS : 875-1987   | Design Loads  |
| 5             | IS 1254         | Corrugated aluminium sheet  |
| 6             | IS 1343         | Prestressed Concrete - Code Of Practice   |
| 7             | IS 2095:2011    | Gypsum Plaster Boards - Specification   |
| 8             | IS 2676         | Dimension for wrought aluminium and aluminium alloy sheet and strip   |
| 9             | IS 4671: 1984   | Specification For Expanded Polystyrene For Thermal Insulation Purposes  |
| 10            | ISO 4898:2008   | Rigid cellular plastics -- Thermal insulation products for buildings -- Specifications  |
| 11            | IS 4990: 2011   | Plywood For Concrete Shuttering Works - Specification   |
| 12            | IS 5688-1982    | Method Of Test For Preformed Block-Type and Pipe-Covering Type Thermal Insulation   |
| 13            | IS 8225:1987    | Measurement Of Sound Absorption In A Reverberation Room   |
| 14            | IS 10297-1982   | Code of practice for design and construction of floors and roofs using precast reinforced prestressed concrete ribbed or cored slab units |
| 15            | IS 11447:1985   | Code of practice for construction with large panel prefabricates  |
| 16            | IS : 13958-1994 | Bamboo mat board for general purposes -Specification  |
| 17            | IS 14862:2000   | Fibre Cement Flat Sheets - Specification  |
| 18            | IS 14862: 2000  | Fibre Cement Flat Sheets - Specification  |
| 19            | IS 14867-1999   | Falsework For Concrete Structures - Guidelines  |
| 20            | IS : 15476-2004 | Bamboo Mat Corrugated Sheets - Specification  |
| 21            | IS 15916        | Building Design and Erection Using Prefabricated Concrete-Code of Practice  |

## 26.0 NEW TECHNOLOGIES & MATERIALS

### 26.1 PHENOL BONDED BAMBOOWOOD FLOORING

#### 26.1.1 MATERIAL

**26.1.1.1 Frame:** The base frame shall be of strong, dry concrete or as specified like plywood or wooden of treated and seasoned and frame shall be leveled and smooth. The Bamboowood flooring tiles shall be fixed with tongue and groove interlocking system, with underlayment of 4mm thick expanded poly ethylene foam sheets having density 40kg/cum, over prepared surface.

#### 26.1.1.2 Flooring Tiles:

The Bamboowood flooring shall be of 14mm thick with tongue and groove inter locking system of micro beveled edges, eco-friendly bamboowood tiles high in density and hardness, made from bamboo grass, a renewable source of raw material.

The Flooring Tiles shall be of size 1800mm length (minimum) and 130mm wide (minimum of 14mm thickness). The Bamboowood planks shall have minimum density of 1000 Kg/m<sup>3</sup> & minimum Hardness 1000 Kgf. The Bamboowood flooring tiles shall have Eco friendly UV coating in approved colour, texture and factory finished, having Performance Appraisal Certificate (PAC) issued by Building Materials & Technology Promotion Council (BMTPC). The flooring tiles shall have necessary quarter round planks of size 1900mm x 18mm and door reducer of size 1900mm x 44mm, wherever required.

The Bamboowood flooring tiles characterized with density, hardness, modulus of rupture, modulus of elasticity, thermal conductivity as per IS: 3346-1980  $\leq 0.50$  W/ m-K, termite resistant as per 6months termite mound test and borer resistant as per box test, scratch resistance as per Hamburger test of  $\geq 20$  N, abrasion resistance as per DIN EN 438-2 of  $> 100$  cycle & ASTM D 4060 of  $> 6000$  cycle & ISO 15184 of  $\geq 1$  H, impact resistance as per DIN EN 438 P2-12 of  $\geq 2$  Newton, Indentation Resistant DIN EN 438 P -14 of  $\geq 1$  Newton, Chemical Resistance DIN 68861 Part 1 of 5, In flammability DIN 4102 Part 14 of B1, Heat Resistance DIN 68861 Part 6 of 6A.

#### 26.1.1.3 Base Material:

Expanded polyethylene foam sheets of 4mm thickness and having density 40kg/m<sup>3</sup>.

#### 26.1.2 Fixing of base work and tiles:

The expanded poly ethylene foam sheets of 4mm thickness and having density 40kg/m<sup>3</sup> of available width and running length as underlayment. Place the foam sheet and seal joints with min. 50 mm width masking tape so that it should not overlap. This foam will take undulation and act as cushion for flooring tiles. Open the boxes of tiles and keep tiles in room for normalizing for 72hrs prior to installation. First check the dimensions with meter tape to calculate the expansion gap to be left for sides. For standard room 12ft x 12ft, the expansion gap shall be 15mm and above to this add 0.5mm for each layer; for width above 25ft gap shall be 30mm. Ends shall have standard 15mm expansion gap all times. Make a right angle along the longer side of area where flooring to be laid by placing marking line and use guide strips as specified above. Then start laying down flooring tiles one after another end to end. Place them against the guide strips along with right angle marking line. Take D-3 category water resistant glue and apply above tongue with a conical shape glue applicator for even layer. And place second line of tiles and push in with first layer from sides and match end to end of this layer. If last tile is longer; then trim the excess and take that to first piece in next layer. Repeat same again and again till complete laying of flooring in whole area. Keep cleaning the excess glue coming up on tile surface with moist cloth. Use Silicon based joint sealant of approved quality for the joints of the tiles. Place door reduce at entrance in last.

### 26.1.3 Precautions:-

- (a) Base concrete must be strong, levelled and dried prior to flooring tiles installation work.
- (b) Bamboowood flooring tiles are ready to use as factory finished hence should be the last job to be carried out in new or under renovation area.
- (c) All wet trades such as plastering, conducting, and painting, walling, Ceiling, Air Conditioning duct work, Electrical chasing or drawing lines & cables, etc should be completed prior to start the flooring works.
- (d) No unauthorized work shall be carried out after flooring is laid.

### 26.1.4 Maintenance Guidelines

Bamboowood flooring shall be maintained by hardwood floor cleaners as recommended to ensure that floor stays looking good. It shall be ensured that hardwood floor cleaners are water based, nontoxic cleaners which have been designed for finished hardwood floors. Cleaner shall be used as per manufacturer's instructions.

Types of Drying Methods for the Floors are as follows:

**Dry mop:** Dirt and grit shall always be removed prior to cleaning Bamboowood floors with an electrostatic dust control mop/ soft mop/ vacuum cleaner. Bristle broom shall be avoided.

**Dry spray:** The area of floor or the cleaning pad shall be mist with the hardwood floor cleaner.

**Wipe:** The floor shall be cleaned with a microfiber cloth or mop using a back and forth motion until it is dry. Soiled mop or cloth shall be replaced once it becomes soiled to avoid streaking.

#### Do's and Don'ts: Do's

- (i) The floor shall be cleaned regularly. Recommendations for cleaning the floor as a guide shall be as follows:
  - Low frequented area (residential) – about every 2-4 weeks
  - Medium frequented area (offices) – about every 1-2 weeks
  - High frequented area (public places) – about every 1-2 days
- (ii) Spills shall be removed promptly
- (iii) Mats at exterior and interior doors shall be placed to trap sand 13 and grit from incoming traffic
- (iv) Heavy furniture or appliances shall always be picked rather than sliding them across the floor
- (v) Any minor scratches or damage shall be repaired using hardwood flooring cleaners

#### Don'ts

- (i) Do not steam mop or wet mop floor surface area after installation. Excess water can cause swelling
- (ii) Do not let sand, dirt or grit build up. They act like sandpaper and actually abrade and dull the floor finish

**26.1.5 Measurements:** Length & breadth of the finished flooring shall be measured correct to a centimeter from wall to wall. The area shall be calculated in square meter correct to two decimal places. Expansion joint area shall not be deducted. No deduction will be made of openings of area upto 0.40 sqm nor shall extra payment be made either for any extra material or labour involved in forming such openings. For opening exceeding 0.40sqm in area , deduction in measurements shall be made but extra will be payable for any extra material or labour involved in making such opening.

**26.1.6 Rates:** The rate shall include cost of all the materials and labour involved in all the operation described above, including.

## **26.2 PHENOL BONDED BAMBOO WOOD IN WALL SKIRTING**

### **26.2.1 MATERIAL**

**26.2.1.1 Frame:** The base frame shall be of strong, dry concrete or as specified like plywood or wood treated and seasoned, frame leveled and smooth. The Bamboowood Wall Skirting tiles shall be fixed with SS screws including rawl plug, with underlayment of 4mm thick expanded poly ethylene foam sheets having density 40kg/cum, over prepared surface.

#### **26.2.1.2 Wall Skirting Tiles:**

The Bamboowood Wall Skirting shall be of 14mm thick with one side quarter rounded of micro beveled edges, eco-friendly bamboowood high in density and hardness, made from bamboo grass, a renewable source of raw material.

The Wall Skirting Tiles shall be of size 1900mm length (minimum) and 85mm wide (minimum of 14mm thickness). The Bamboowood planks shall have minimum density of 1000 Kg/m<sup>3</sup> & minimum Hardness 1000 Kgf. The Bamboowood Wall Skirting tiles shall have Eco friendly UV coating in approved colour, texture and factory finish, having Performance Appraisal Certificate (PAC) issued by Building Materials & Technology Promotion Council (BMTPC).

The Bamboowood wall skirting tiles shall be characterized with density, hardness, modulus of rupture, modulus of elasticity, thermal conductivity as per IS: 3346-1980  $\leq 0.50$  W/ m-K, termite resistant as per 6months termite mound test and borer resistant as per box test, scratch resistance as per Hamburger test of  $\geq 20$  N, abrasion resistance as per DIN EN 438-2 of  $> 100$  cycle & ASTM D 4060 of  $> 6000$  cycle & ISO 15184 of  $\geq 1$  H, impact resistance as per DIN EN 438 P2-12 of  $\geq 2$  Newton, Indentation Resistant DIN EN 438 P-14 of  $\geq 1$  Newton, Chemical Resistance DIN 68861 Part 1 of 5, Inflammability DIN 4102 Part 14 of B1, Heat Resistance DIN 68861 Part 6 of 6A.

#### **26.2.1.3 Base Material:**

Expanded poly ethylene foam sheets of 4mm thickness and having density 40kg/m<sup>3</sup> of available with and running length.

### **26.2.2 Fixing of base work and tiles:**

Place the foam sheet and seal joints with masking tape so that it should not overlap. This foam will take undulation and act as cushion for skirting tiles. Open the boxes of tiles and keep tiles in room for normalizing for 72hrs prior to installation. Place the wall skirting 2mm above the bamboowood tiles flooring surface. Use drill machine to make suitable holes in tiles at both ends and accordingly make holes for rawl plug in wall. Place the rawl plug and then foam and over that place wall skirting tiles and held in place by 50mm SS screws at both ends. Repeat same for entire area. Wall Skirting used to cover the small area expansion gaps. For larger area expansion gaps need quarter round as shoe to cover the expansion gap on all sides. Use Silicon based joint sealant of approved quality for the joints of the tiles.

### **26.2.3 Precautions:-**

- (a) Base concrete must be strong, leveled and dried prior to flooring tiles installation work.
- (b) Bamboowood wall skirting tiles are ready to use as factory finished hence should be the last job to be carried out in new or under renovation area.
- (c) All wet trades such as plastering, conduiting, and painting, walling, Ceiling, Air Conditioning duct work, Electrical chasing or drawing lines & cables, flooring, wall cladding etc should be completed prior to start of skirting works.
- (d) No unauthorized work shall be carried out after flooring laid.

#### **26.2.4 Measurements:**

Length & breadth of the finished Wall Skirting shall be measured correct to a centimeter. The length & breadth shall be calculated in running meter correct to two decimal places. All sides length & breadth where wall skirting is installed shall be measured. No deduction will be made for openings of areas upto 0.40 sqm nor shall extra payment be made either for any extra material or labour involved in forming such openings. For opening exceeding 0.40sqm in area, deduction in measurements shall be made but extra will be payable for any extra material or labour involved in making such opening.

**26.2.5 Rates:** The rate shall include cost of all the materials and labour involved in all the operation described above.

### **26.3 PHENOL BONDED BAMBOOWOOD WALL CLADDING**

#### **26.3.1 MATERIAL**

**26.3.1.1 Frame:** The frame shall be made of second class teak wood of treated and seasoned of size 20x15mm in centre of each tile and bottom and top of work height, 40x15mm placed at ends of each tile. The frame shall be fixed to wall with 50mm SS screws and raw plug. The Bamboowood wall cladding shall be laid over back layment of 1.00mm thick expanded poly ethylene foam of density 40kg/cum in two layers first layer on wall surface before fixing wooden frame and second layer on frame under cladding.

#### **26.3.1.2 Wall Cladding Tiles:**

The Bamboowood Wall Cladding tiles shall be of 10mm thick with profiled edges. Eco friendly bamboowood wall cladding tiles high in density and hardness, made from bamboo grass, a renewable source of raw material.

The Wall Cladding Tiles shall be of size 1800mm length (minimum) and 130mm wide (minimum) of 10mm thickness. The Bamboowood planks shall have minimum density of 1000 Kg/m<sup>3</sup> & minimum Hardness 1000 Kgf. The Bamboowood wall cladding tiles shall have Eco friendly UV coating in approved colour, texture and factory finish, having Performance Appraisal Certificate (PAC) issued by Building Materials & Technology Promotion Council (BMTPC). The wall cladding tiles shall have necessary threshold of size 1900mm x 44mm and T mold of size 1900mm x44mm wherever required.

The Bamboowood wall cladding tiles shall be characterized with density, hardness, modulus of rupture, modulus of elasticity and thermal conductivity as per IS: 3346-1980  $\leq 0.50$  W/ m-K, termite resistant as per 6months termite mound test and borer resistant as per box test, scratch resistance as per Hamburger test of  $\geq 20$  N, abrasion resistance as per DIN EN 438-2 of  $> 100$  cycle & ASTM D 4060 of  $>6000$  cycle & ISO 15184 of  $\geq 1$ H, impact resistance as per DIN EN 438 P2-12 of  $\geq 2$  Newton, Indentation Resistant DIN EN 438 P-14 of  $\geq 1$  Newton, Chemical Resistance DIN 68861 Part 1 of 5, In flammability DIN 4102 Part 14 of B1, Heat Resistance DIN 68861 Part 6 of 6A.

#### **26.3.1.3 Base Material:**

Expanded poly ethylene foam sheets of 1mm thickness and having density 40kg/m<sup>3</sup> and second class teak wood of treated and seasoned.

#### **26.3.2 Fixing of base work and tiles:**

The expanded poly ethylene foam sheets of 1mm thickness and having density 40kg/m<sup>3</sup> of available width and running length as backlayment. Place the foam sheet and seal joints with masking tape so that it should not overlap. The frame shall be made of second class teak wood of treated and seasoned of size 20x15mm in centre of each tile and bottom and top of work height, 40x15mm placed at ends of each tile. The frame shall be fixed to wall with 50mm SS screws and

rawl plug. The frame shall be laid over first layer of foam. Open the boxes of tiles and keep tiles in room for normalizing for 72hrs prior to installation. Make a right angle along the length and height of wall by keeping a 10mm gap with all. The Bamboowood wall cladding shall be laid over backlayment of 1.00mm thick expanded poly ethylene foam of density 40kg/cum on frame under cladding. Use pneumatic installation gun and tools of pressure 7bar and use BR18G nails. Place wall cladding tile and hit in head and toe and in centre to pace it. Keep a gap of minimum 3.00mm between two wall cladding tiles and continue laying as explained above. One can increase gap between tiles as per their requirement as well. Use T-mold to join two tiles at the ends and threshold in top and bottom of wall cladding to give a pleasing looks.

### **26.3.3 Precautions:-**

- (a) Base concrete must be strong, leveled and dried prior to flooring tiles installation work.
- (b) Bamboowood wall cladding tiles are ready to use as factory finished hence should be the last job to be carried out in new or under renovation area.
- (c) All wet trades such as plastering, conducting, and painting, walling, Ceiling, Air Conditioning duct work, Electrical chasing or drawing lines & cables, etc should be completed prior to start of cladding works.
- (d) No unauthorized work shall be carried out after wall cladding installation.

### **26.3.4 Measurements:**

Height & breadth of the finished Wall cladding shall be measured correct to a centimeter from wall to wall. The area shall be calculated in square meter correct to two decimal places. Expansion area shall not be deducted. No deduction will be made of openings of area upto 0.40 sqm nor shall extra payment be made either for any extra material or labour involved in forming such openings. For opening exceeding 0.40sqm in area, deduction in measurements shall be made but extra will be payable for any extra material or labour involved in making such opening.

**26.3.5 Rates:** The rate shall include cost of all the materials and labour involved in all the operation described above, including Frame work mentioned in para above including material & hardware consumed /utilized.

## **26.4 PHENOL BONDED BAMBOOWOOD PANELLED OR PANELLED AND GLAZED SHUTTERS FOR DOORS WINDOWS, CLERESTOREY WINDOWS**

### **26.4.1 MATERIAL**

**26.4.1.1 Frame:** The door frame (chowkhat) shall be of wooden of treated and seasoned or Bamboowood or as specified material. The opening for Shutter of door shall be levelled and smooth. The Shutter for door shall have profiled interlocking system and be fixed with bamboo pins in position. The Shutter shall fix to door frame with SS hinges and screws.

### **26.4.1.2 Shutters of doors:**

The Bamboowood Shutters of doors shall be of 30mm thick with pre - molded planks having inter locking system of micro bevelled edges, eco-friendly bamboowood of high in density and hardness, made from bamboo grass, a renewable source of raw material.

The Shutters of doors shall be of 30mm thick bamboowood planks. The Bamboowood planks shall have minimum density of 1000 Kg/m<sup>3</sup> & minimum Hardness 1000Kgf. The bamboowood shutters of doors shall have approved coating in approved colour, texture and factory finished. The bamboowood shall have Performance Appraisal Certificate (PAC) issued by Building Materials & Technology Promotion Council (BMTPC). The shutter of doors shall have necessary profile to fit in panelling as required.



The Bamboowood planks pre - molded into shutters of doors characterized with density, hardness, modulus of rupture, modulus of elasticity, thermal conductivity as per IS: 3346-1980  $\leq 0.50$  W/ m-K, termite resistant as per 6months termite mound test and borer resistant as per box test.

#### **26.4.1.3 Base Material:**

Door frame of wood or metal or Bamboowood or aluminum or others as specified.

#### **26.4.2 Fixing of Shutter of doors:**

The pre-molded planks of Bamboowood shutters of doors shall have 10mm wide and 25mm deep grooves to fit in panels. These planks shall be in vertical and horizontal (middle, top n bottom) rails. The panels shall fit in rails and all these planks shall fixed together and held in place by bamboo pins. Doors accessories shall be of adequate metal such as stainless steel butt hinges of size 125x65x1.9mm and minimum 4nos with minimum 4 screws per hand, making 8screws per hinge to be used. Another fittings like door handle, lock and bolts etc as specified. Normalize doors prior to installation for 72hrs. First check the dimensions of door frame opening with meter tape and match same with shutter of door at site; accordingly take installation of shutters of door in frame forward. There should be a movement gap left between shutter and door frame. Trained carpenter can work easily on Bamboowood shutters of doors. The carpenter shall use modern hand tools and machines for better results.

#### **26.4.3 Precautions:-**

- (a) Frame of Door shall be fixed properly with concrete and must be strong, levelled and dried prior to shutter door installation work.
- (b) Bamboowood shutters of doors are ready to use as factory finished hence precautions should be carried out in new or under renovation area.
- (c) All wet trades such as plastering, conducting, and painting, walling, Ceiling, Air Conditioning duct work, Electrical chasing or drawing lines & cables, etc should be completed prior to installation of doors works.
- (d) No unauthorized work shall be carried out after shutter of doors in place at that area.

#### **26.4.4 Measurements:**

Length & breadth of the shutters of doors shall be measured correct to a centimeter in fixed position (overlapping not to be measured in case of double leaved shutters) and the area calculated in square meter corrected to two place of decimal. No deduction shall be made to form panel openings or louvers . No extra payments shall be made for shape, joints and labours included in all operation describe above.

**26.4.5 Rates:** The rate shall include cost of all the materials and labour involved in all the operation described above, including Frame work mentioned in para above including material & hardware consumed /utilized.

### **26.5 PHENOL BONDED BAMBOO WOOD PANELING**

#### **26.5.1 MATERIAL**

**26.5.1.1 Frame:** The shutters of doors shall be of Bamboowood planks. The shutter of door shall have 10mm grooves for panelling to fit in and be leveled and smooth. The panelling for shutters of doors shall have profiled interlocking system and be fixed with shutters of doors.



### **26.5.1.2 Panelling for shutters of doors:**

The Bamboowood panelling for shutters of doors shall be of 10mm thick with pre - molded planks having inter locking system of micro beveled edges, eco-friendly bamboowood, high in density and hardness, made from bamboo grass, a renewable source of raw material.

The panelling for shutters of doors shall be of 10mm thick bamboowood planks. The Bamboowood panel tiles shall have minimum density of 1000 Kg/m<sup>3</sup> & minimum Hardness 1000Kgf. The bamboowood panel tiles for shutters of doors shall have approved coating in approved colour, texture and factory finished. The bamboowood panels shall have Performance Appraisal Certificate (PAC) issued by Building Materials & Technology Promotion Council (BMTPC). The shutter of doors shall have necessary profile to fit in paneling as required.

The Bamboowood panels pre - molded to fit in shutters of doors characterized with density, hardness, modulus of rupture, modulus of elasticity, thermal conductivity as per IS: 3346-1980  $\leq 0.50$  W/ m-K, termite resistant as per 6months termite mound test and borer resistant as per box test.

### **26.5.1.3 Base Material:**

Shutters of door shall be made of Bamboowood to fit in panelling.

### **26.5.2 Fixing of Panelling for shutter of doors:**

The pre-molded panels of Bamboowood shutters of doors shall have 10mm thickness. The shutters of doors shall have 10mm wide and 25mm deep groove to fit in panelling. The panels shall fit in rails and all these panels shall be fixed together to smooth level and whole shutter of door with panel locked in and held in place by bamboo pins. Normalize doors prior to installation for 72hrs. First check the dimensions of door frame opening with meter tape and match same with shutter of door at site; accordingly take installation of panelled shutters of door to fix in frame of door. There should be a movement gap left between shutter and door frame. Trained carpenter can work easily on Bamboowood panelled shutter doors. The carpenter shall use modern hand tools and machines for better results.

### **26.5.3 Precautions:-**

- (a) Frame of Door shall be fixed properly with concrete and must be strong, leveled and dried prior to shutter door installation work.
- (b) Bamboowood panelled shutters of doors are ready to use as factory finished hence precautions should be carried out in new or under renovation area.
- (c) All wet trades such as plastering, conducting, and painting, walling, Ceiling, Air Conditioning duct work, Electrical chasing or drawing lines & cables, etc should be completed prior to installation of doors works.
- (d) No unauthorized work shall be carried out after panelled shutter of doors in place at that area.

### **26.5.4 Measurements:**

For paneling of shutters of door, length & width of panels shall be measured correct to a centimetre and the area shall be calculated to the nearest 0.01sqm. The portion of panels insert or glazed panel inside the grooves or rebates shall be measured for payment.

**26.5.5 Rates:** The rate shall include cost of all the materials and labour involved in all the operation described above.

## **26.6 FACTORY MADE DOOR FRAME OF PHENOL BONDED BAMBOOWOOD**

### **26.6.1 MATERIAL**

**26.6.1.1 Frame:** The door frame (chowkhat) opening shall be of strong, or as specified and leveled and smooth. The Bamboowood frame for doors shall have 10mm gap between concrete and frame. The frame shall have interlocking system of rails and gap filling foam as back lument, over prepared surface.

#### **26.6.1.2 Frame for doors:**

The Bamboowood frame for doors shall be 65mm thick with pre - molded planks having inter locking system of micro beveled edges, eco-friendly bamboowood high in density and hardness, made from bamboo grass, a renewable source of raw material.

The Frames shall be of 65mm thick bamboowood planks. The Bamboowood planks shall have minimum density of 1000 Kg/m<sup>3</sup> & minimum Hardness 1000Kgf. The bamboowood frames shall have approved coating in approved colour, texture and factory finished. The bamboowood shall have Performance Appraisal Certificate (PAC) issued by Building Materials & Technology Promotion Council (BMTPC).

The Bamboowood planks pre - molded into frame for doors characterized with density, hardness, modulus of rupture, modulus of elasticity, thermal conductivity as per IS: 3346-1980  $\leq 0.50$  W/ m-K, termite resistant as per 6months termite mound test and borer resistant as per box test.

#### **26.6.1.3 Base Material:**

Strong, dry concrete or as specified and smooth and leveled.

### **26.6.2 Fixing of Frames:**

The pre-molded planks of Bamboowood frames shall have interlocking provisions between vertical and horizontal rails. The frame shall be fixed to strong, dry concrete with jamb. The jamb shall fixed on both sides of frame with 2nos of 100mm GI screws per jamb and 3nos of jamb each side first and then insert other end of jamb into concrete hole and locked bamboowood frame in place by concrete. There shall be a air gap of 10mm all around to bamboowood frame and this gap to be filled with PU foam and covered with architraves.

### **26.6.3 Precautions:-**

- (a) Concrete must be strong, leveled and dried prior to installation of bamboowood frame of door.
- (b) Bamboowood frame ready to use as factory finished hence precautions should be carried out in new or under renovation area.
- (c) Jamb should be fixed to sides of frame at equal interval and jamb hole should be made in advance in concrete prior to installation work.
- (d) All wet trades such as plastering, conducting, and painting, walling, Air Conditioning duct work, Electrical chasing or drawing lines & cables, etc should be completed prior to installation of frame works.
- (e) No unauthorized work shall be carried out after installation of frame at place.

### **26.6.4 Measurements:**

Length & breadth of the frame shall be measured correct to a centimeter as per approved drawings and prior to installation work. Rails of verticals and horizontal shall be measured with pre-molded profiles. Inserts of rails shall be measured as thickness of top rail as 65mm. These inserts shall be

taken into account of measurements. The volume shall be calculated in cum correct to four decimal places. No deduction shall be made inserts. Installation of frame of doors and fitting of accessories shall be extra payment and be made for labour involved in making such openings.

#### **26.6.5 Rates:**

The rate shall include cost of all the materials and labour involved in all the operation described above.

### **26.7 BAMBOO MAT CORRUGATED SHEET (BMCS)**

#### **26.7.1 MATERIAL**

Material and testing criteria as per IS 15476:2004 ( upto amendment No.-4)

#### **26.7.2 Fixing Procedure:-**

1. The roof slope should be minimum 20° OR maximum 45°.
2.
  - (a) For 2440mm long BMCS, the purlin spacing should be @ 1145mm centre to centre.
  - (b) For 2140mm long BMCS, the purlin spacing should be @ 995mm centre to centre.
  - (c) For 1830mm long BMCS, the purlin spacing should be @ 840mm centre to centre.
  - (d) In the same Horizontal Plan, the purlin level (Elevation) at all points must be same to avoid concave / convex formation of BMCS's surface which will obstruct the proper flow of water on the BMCS, as shown in the figure no. 26.1
  - (e) The rafter (1), (2), (3), (4) etc. as shown in figure 26.1, must be perfectly straight otherwise it will give concave / convex surface of BMCS which will obstruct the proper flow of water.
3. Minimum 6" (150mm) end lap to be provided while fitting the BMCS on Purlins. See figure no. 26.2
4. The Standard width of BMCS is 1050mm. There are 9 nos. of Crown and 8 nos. of Valley in One BMCS of standard width of 1050mm. See figure no.26.3
5. One Corrugation side lap of 110mm to be provided while fitting the BMCS on Purlins. See figure no. 26.4 below:
6. BMCS & BMRC to be fitted with Self-Drilling Screws with Stainless Steel EPDM bonded washers complete (See figure no. 26.5) OR 8mm diameter J Hooks / L Hooks, Bolts, nuts, bitumen washer, galvanized washers complete. (See figure no. 26.6). NAIL should never be used for fitting the BMCS & BMRC.
7. For fitting the Self-Drilling Screws OR J Hooks / L Hooks, Bolts, nuts etc., the correct size hole in the BMCS & BMRC must be made with Drill Machine only. The holes should never be made by PUNCH, as it will crack the BMCS & BMRC.
8. The holes for fixing the Self-Drilling Screws OR J Hooks / L Hooks, Bolts, nuts etc. to be made on the APEX (Crest) only and NOT in the Valley. See figure no. 26.5 & 26.6.
9. At least one of the fixing Self-Drilling Screws OR J Hooks / L Hooks, Bolts, nuts etc. to pass through the end lap of BMCS / BMRC. If it is not possible, extra Self-Drilling Screws OR J Hooks / L Hooks, Bolts, nuts etc. to be provided. The end lap of BMCS / BMRC to be jointed together. The edges of the BMCS & BMRC should be straight when fixed end to end and the surface to be plain and parallel to the general plan of the roof. See figure no. 26.7 below:

10. Free overhanging of BMCS to be not more than 300mm.
11. The BMRC Ridge purlin to be fitted at a distance of 200mm from the Apex of the Truss / Roof. See figure no. 26.7.
12. Polyurethane (PU) Coating Green colour / any other colour coated side must face the SUN to resist severe Heat & Rain.
13. Polyurethane (PU) Coating Green colour / any other colour of Exterior quality to be applied after every five years for longer life of the BMCS / BMRC.

#### **26.7.3 Precautions:-**

BMCS / BMRC cutting should be done with Fine Teeth Carpenter hand saw / electric hand cutting machine and after cutting, the edges to be sealed with any of the following sealants available in the markets:

- (i) Exterior Grade quality Varnish
- (ii) Polyurethane Coating of Exterior Grade quality
- (iii) Bituminized Rubber sealant.
- (iv) Silicon Based sealant.

The products should be handled with care and the product should not fall on edges during handling, unloading and loading process.

The BMCS / BMRC procured from must be stored in a covered shed/ location at site with sufficient cross ventilation inside the covered shed/ location. The BMCS / BMRC must also be stacked on elevated wooden pallets which are not touching the ground level.

#### **26.7.4 Finish:-**

The complete roof shall present a neat and uniform appearance and be leak proof.

#### **26.7.5 Measurements:- ( for DSR'18 item 26.6A)**

Length and breadth shall be measured correct to a cm and its area shall be calculated in square metres correct to two place of decimal.

The superficial area of roof covering shall be measured on the flat without allowance for laps and corrugations. Portion of roof covering overlapping the ridge etc. shall be included in the measurements of the roof.

No deduction in measurements shall be made for the opening upto 0.4 sqm and nothing extra shall be allowed for forming such opening. For any opening exceeding 0.40 sqm in area, deduction in measurements for the full opening shall be made and in such case the labour involved in making these openings shall be paid separately. Cutting across corrugation shall be measured on the flat and not grithed.

#### **26.7.6 Rates:**

The rate shall include cost of all the materials and labour involved in all the operation described except otherwise stated. This includes the cost of roof sheets, L hook, bolts and nuts, bituminous and galvanized iron washers.

#### **26.7.7 Measurements:- ( for DSR'18 item 26.6B)**

The measurement for ridges and hips shall be taken for the finished work along the centre line of the ridge and hip lines in length , correct to a cm . the laps in adjacent ridges pieces shall not be measured. The underlay of ridges under expansion joint pieces where the latter are provided shall however be measured.

### **26.7.8 Rates:-**

The rates shall include the cost of all material and labour specified above, but does not include (a) the cost of required hook, bolt nuts and screws and their washers, (b) the cost of supplying and fixing expansion joint pieces, (c) the cost of closing the gaps between plain ridge and the sheet roofing corrugation. Item(a) above will be covered by the rate of BMCS roofing while item (b) & (c) will be paid for separately unless specifically included in the description of item of the BMRC.

## **26.8 PHENOL BONDED BAMBOO MAT BOARD FOR FALSE CEILING**

### **26.8.1 Material**

Material and testing criteria as per IS:13958-1994 ( upto amendment No.-4)

#### **26.8.1.1 Frame**

The frame work shall consist of GI Tee sections for main runners of size 30x25x0.3 mm thick and for cross runners of size 25x25x0.3 mm thick and parameter wall angle of GI section of size 25x25x0.4 mm thick fixed to the wall with dash hold fastner 12.5 mm dia and 50 mm long . The frame work shall be executed in a manner so as to form a grid of 600 mm x 600 mm as specified in the item. The frame work shall be suspended from ceiling by level adjusting hangers made of 4 mm dia. GI rods fixed to slab by means of GI ceiling cleats. The ceiling cleats shall be fixed to the slab by means of mechanical dash fasteners 12.5 mm dia and 50 mm long. MS hangers and ceiling cleats shall be painted with a coat of yellow zinc chromate primer and two coats of synthetic enamel paint.

#### **26.8.1.2 Ceiling Tiles**

Ceiling tiles shall be of 4 mm thick phenol bonded Bamboo mat board bound confirm to IS 13958-1994 of required size.

### **26.8.2 FIXING OF CEILING TILES**

The ceiling tiles shall be placed over the GI frame.

### **26.8.3 Measurements**

Length & breadth of the finished ceiling shall be measured correct to a centimetre. The area shall be calculated in square metre correct to two decimal places. No deduction shall be made for making openings for electrical, air conditioning, fire fighting fixtures nor shall extra payment be made either for extra materials or labour involved in making such openings.

### **26.8.4 Rate**

The rate shall include the cost of all the materials and labour involved in all the operation described above including frame work, scaffolding etc.

## **26.9 BAMBOO MAT BOARD FOR PARTITION TO FRAME**

### **26.9.1 MATERIAL**

Material and testing criteria as per IS:13958-1994 ( upto amendment No.-4)

#### **26.9.1.1 Frame**

The base frame work to be executed as per items specified and as per direction of Engineer-in-Charge

### **26.9.2 Fixing Procedure:-**

- (a) Sawing of Bamboo mat board shall be truly straight and square. The Bamboo mat board shall be planed smooth and accurate to the full dimensions, rebates, roundings, and mouldings as shown in the drawings made, before assembly. Patchings or plugging of, any kind shall not be permitted except as provided

- (b) Bamboo mat board can be screwed or nailed as per the requirement on the existing frame work.
- (c) The screws used for fixing the mat board shall be sunk into the wood work and their tops covered with putty.
- (d) When the Bamboo mat board is cut, the edges has to be sealed by using any of the following sealants available in the market.
  - (i) Exterior Grade quality Varnish
  - (ii) Polyurethane Coating of Exterior Grade quality
  - (iii) Bituminized Rubber sealant.
  - (iv) Silicon Based sealant.
- (e) Bamboo mat board, if used for outside (exterior) a waterproofing coating to be provided on the board for each longer life against weathering effects.
- (f) Cutting should be done with fine teeth carpenter hand saw/ electric hand cutting machine.
- (g) The ornament work shall be made if required in true and accurate to the dimensions shown in the working drawings.
- (h) The fixing shall be done true to line and levels.

#### **26.9.3 Precautions:-**

The Bamboo mat board must be stored in a covered shed/ location with sufficient cross ventilation inside the covered shed/ location. The Bamboo mat board must also be stacked on the elevated wooden pallets which are not touching the ground level. The product should be handled with care and the product should not fall on edges during handling, unloading and loading process.

#### **26.9.4 Measurements:**

Length and breadth shall be measured correct to a cm. Bamboo mat board used for partition work shall be measured in square metre nearest to two places of decimal. The moulded work shall be measured in cm running metre i.e. in running metres stating the girth in cm. The sectional periphery (girth) of moulding excluding the portion in contact with wall shall be measured in cm correct to 5 mm and length in metre correct to a cm. No deduction will be made of openings of area upto 0.40 sqm nor shall extra payment be made either for any extra material or labour involved in forming such openings. For opening exceeding 0.40sqm in area, deduction in measurements shall be made but extra will be payable for any extra material or labour involved in making such opening.

#### **26.9.5 Rates:**

The rate includes the cost of materials and labour required for all the operation described above but excluding the cost of backing or studding.

### **26.10 WALL PANELLING WITH PHENOL BONDED BAMBOO MAT BOARD**

#### **26.10.1 MATERIAL**

Material and testing criteria as per IS:13958-1994 ( upto amendment No.-4)

#### **26.10.2 Grounds**

Grounds shall be provided where so specified. These shall consist of first class hard wood plugs or the class of wood used for fabricating the frames, of trapezoidal shape having base of 50 × 50 mm and top 35 × 35 mm with depth of 5.0 cm and embedded in the wall with cement mortar 1:3 (1 cement : 3fine sand) and batten of first class hard wood or as specified of size 50 × 25 mm or as specified, fixed over the plugs with 50 mm long wood screws. The plugs shall be spaced at 45 to 60 centimeters centre to centre, depending upon the nature of work. The battens shall be painted with priming coat, of approved wood primer before fixing.



### **26.10.3 Fixing Procedure:-**

- (a) Sawing of Bamboo mat board shall be truly straight and square. The Bamboo mat board shall be planed smooth and accurate to the full dimensions, rebates, roundings, and mouldings as shown in the drawings made, before assembly. Patchings or plugging of, any kind shall not be permitted except as provided
- (b) Bamboo mat board can be screwed or nailed as per the requirement on the existing frame work.
- (c) The screws used for fixing the mat board shall be sunk into the wood work and their tops covered with putty.
- (d) When the Bamboo mat board is cut, the edges has to be sealed by using any of the following sealants available in the market.
  - (i) Exterior Grade quality Varnish
  - (ii) Polyurethane Coating of Exterior Grade quality
  - (iii) Bituminized Rubber sealant.
  - (iv) Silicon Based sealant.
- (e) Bamboo mat board, if used for outside (exterior) a waterproofing coating to be provided on the board for each longer life against weathering effects.
- (f) Cutting should be done with fine teeth carpenter hand saw/ electric hand cutting machine.
- (g) The ornament work shall be made if required in true and accurate to the dimensions shown in the working drawings.
- (h) The fixing shall be done true to line and levels.

### **26.10.4 Precautions:-**

The Bamboo mat board must be stored in a covered shed/ location with sufficient cross ventilation inside the covered shed/ location. The Bamboo mat board must also be stacked on the elevated wooden pallets which are not touching the ground level. The product should be handled with care and the product should not fall on edges during handling, unloading and loading process.

### **26.10.5 Measurements:**

Length and breadth shall be measured correct to a cm. Bamboo mat board used for paneling work shall be measured in square metre nearest to two places of decimal. The moulded work shall be measured in cm running metre i.e. in running metres stating the girth in cm. The sectional periphery (girth) of moulding excluding the portion in contact with wall shall be measured in cm correct to 5 mm and length in metre correct to a cm. No deduction will be made of openings of area upto 0.40 sqm nor shall extra payment be made either for any extra material or labour involved in forming such openings. For opening exceeding 0.40sqm in area, deduction in measurements shall be made but extra will be payable for any extra material or labour involved in making such opening.

Where only plugs are required to be fixed for the ornamental work, the cost for the same shall be deemed to be included in the rate of ornamental work and no separate payment shall be made for plugs.

### **26.10.6 Rates:**

The rate includes the cost of materials and labour required for all the operation described above but excluding the cost of backing or studding.

The testing of bamboowood products and the criteria as listed in Table No.26.1

## TESTING CRITERIA OF MATERIAL

Table No. 26.1

| Sl no.  | Characteristic                     | Test Method                             | Criteria  |
|---|------------------------------------|---|---|
| <b>I. Bamboowood ( General Test)</b>                                    |                                    |   |   |
| Sl no.  | Characteristic                     | Test Method                             | Criteria  |
| 1   | Density                            | IS: 1708 ( Part 2)1986                  | ≥ 1000Kg /m <sup>3</sup>  |
| 2   | Modulus of Rupture (MOR)           | IS: 1708 ( Part 5)1986                  | ≥ 150 N /mm <sup>2</sup>  |
| 3   | Modulus of Elasticity (MOE)        | IS: 1708 ( Part 5)1986                  | ≥ 17500 N /mm <sup>2</sup>  |
| 4   | Hardness Test                      | IS :1708 ( Part 10), ASTM D 1037        | ≥ 800 kg  |
| 5   | Moisture Content                   | IS: 1708 ( Part-1)1986<br>ASTM D 4442   | ≤12% ( oven dry method)   |
| <b>II. Bamboowood ( Specialized Test)</b>                               |                                    |   |   |
| 1   | Thermal Conductivity               | IS: 3346-1980                           | ≤ 0.50W/m-k   |
| 2   | Volatile organic compound          | IS; 13745-1993                          | ≤8.00mg/100gm (oven dry method)   |
| 3   | Termite Test                       | Laboratory Test                         | 6 month in Termite Mound  |
| 4   | Borer Test                         | Laboratory Test                         | 6 month in Borer Box  |
| 5   | Flame penetration                  | IS: 1734 (part-3) 1983                  | ≥30 min   |
| 6   | Water Absorption                   | IS 2380-1981                            | ≤ 4% (2 hrs), ≤ 8% (24 hrs)   |
| 7   | Swelling due to general absorption | IS 2380-1981                            | ≤ 8%  |
| 8   | Swelling due to surface absorption | IS 2380-1981                            | ≤ 4% (2 hrs), ≤ 8% (24 hrs)   |
| 9   | Flammability                       | IS: 1731 (Part-3) 1983                  | ≥ 5 min (time taken for second ignition)  |
| 10  | Rate of burning                    | IS 2380-1981                            | ≥ 10 min (time taken to lose weight from 70% to 30%)  |
| 11  | Screw withdrawal Resistance        | IS: 2380-1981                           | ≥ 250 Kg (Flat Face)  |
| 12  | Screw withdrawal Resistance        | IS: 2380-1981                           | ≥ 200 Kg (Edge)   |
| <b>III. Flooring/ Wall Cladding Finish (General Test)</b>               |                                    |   |   |
| 1   | Gloss Value                        | DIN EN ISO 2813                         | 30 ± 5%   |
| 2   | Scratch Resistance Coin Test       | Coin Test                               | No Scratch  |
| 3   | Heat Resistance (Cigarette Test)   | DIN 68861 Part 6                        | 6A  |
| <b>II. Material : Flooring/ Wall Cladding Finish (Specialized Test)</b> |                                    |   |   |
| 1   | Cross cut test                     | DIN EN ISO 2409                         | ≤ GT 2  |
| 2   | Scratch Resistance Coin Test       | Hamburger planner                       | ≥ 20 Newton   |
| 3   | Abrasion Resistance                | DIN EN 438-2 (500g load per wheel S 33) | Initial Point > 100 cycle   |
| 4   | Abrasion Resistance                | ASTM D 4060 (500g load per wheel CS 17) | Initial point > 6000 cycle  |
| 5   | Scratch Resistance pencil Hardness | ISO 15184                               | ≥ 1H  |
| 6   | Scratch Resistance surface         | Steel wool test, type 2                 | No scratch  |
| 7   | Impact Resistance                  | DIN EN 438 part2 – 12                   | ≥ 2 Newton  |
| 8   | Resistance to indentation          | DIN EN 438 part2 – 14                   | ≥ 1 Newton  |
| 9   | Chemical Resistance                | DIN 68861 part 1                        | 5   |
| 10  | In flammability                    | DIN 4102 part 14                        | B1  |
| <b>IV. Bamboo Mat Corrugated Sheets( BMCS)</b>                          |                                    |   |   |
| Sl no.  | Characteristic                     | Test Method                             | Criteria  |
| 1   | Density, gm/cm <sup>2</sup>        | IS :15476:2004                          | 0.75 Min  |
| 2   | Load bearing capacity. N/mm        |   |   |
| a   | Dry state                          | IS :15476:2004                          | 4.0 Min   |
| b   | Wet state                          | IS :15476:2004                          | 3.0 Min   |
| 3   | Impermeability                     | IS :15476:2004                          | The lower surface shall not show any formation of drop of water except for traces of moisture |



|  |   |                        |   |
|--|---|------------------------|---|
| 4  | Water absorption, Percent ( after 24 h soaking)                 | IS :15476:2004         | 15, Max   |
| 5  | Cycle test  | IS :15476:2004         | No delamination   |
| 6  | Resistance to falling weight.                                   |                        | The test piece shall not break or show any crack or tear. |
| 7  | Resistance to fire  |                        |   |
| a  | Flame penetration   | IS :15476:2004         | Not less than 10 min                                      |
| b  | Rate of burning   | IS :15476:2004         | Not less than 20 min                                      |
| c  | Surface spread of flame maximum area of char in mm <sup>2</sup> | IS :15476:2004         | 4500  |
| <b>V. Bamboo Mat Board for general purpose</b> |   |                        |   |
| 1  | Internal Bond Strength Test                                     |                        |   |
| a  | In Dry State  |                        |   |
| i  | An average of six test specimen                                 | IS:2380( Part 5):1977  | 0.70 N/mm <sup>2</sup>                                    |
| ii   | Minimum   | IS:2380( Part 5):1977  | 0.50 N/mm <sup>2</sup>                                    |
| b  | In Wet State  |                        |   |
| i  | An average of six test specimen                                 | IS:2380( Part 5):1977  | 0.50 N/mm <sup>2</sup>                                    |
| ii   | Minimum   | IS:2380( Part 5):1977  | 0.30 N/mm <sup>2</sup>                                    |
| c  | Mycological Test  |                        |   |
| i  | An average of six test specimen                                 | IS:2380( Part 5):1977  | 0.50 N/mm <sup>2</sup>                                    |
| ii   | Minimum   | IS:2380( Part 5):1977  | 0.30 N/mm <sup>2</sup>                                    |
| 2  | Surface Strength Test   |                        |   |
| a  | In Dry State  |                        |   |
| i  | An average of six test specimen                                 | IS:2380( Part 22):1981 | 4.50 N/mm <sup>2</sup>                                    |
| ii   | Minimum   | IS:2380( Part 22):1981 | 3.00 N/mm <sup>2</sup>                                    |
| b  | In Wet State  |                        |   |
| i  | An average of six test specimen                                 | IS:2380( Part 22):1981 | 3.00 N/mm <sup>2</sup>                                    |
| ii   | Minimum   | IS:2380( Part 22):1981 | 2.00 N/mm <sup>2</sup>                                    |
| c  | Mycological Test  |                        |   |
| i  | An average of six test specimen                                 | IS:2380( Part 22):1981 | 3.00 N/mm <sup>2</sup>                                    |
| ii   | Minimum   | IS:2380( Part 22):1981 | 2.00 N/mm <sup>2</sup>                                    |

## 26.11 EXTRUDED POLYSTYRENE RIGID INSULATION BOARD

### 26.11.1 MATERIALS

50mm thick extruded polystyrene rigid insulation board of required size between cavity wall, complying with ISO 4898:2008 & ASTM C 578-08b-type VI, having thermal conductivity of 0.0289 W/mk as per ASTM C 578 (Measured as per IS 3346), Compressive strength of > 350 KPA listed as per ASTM D 1621, density of 34-36 kg/Cum as per ASTM D 1622, Water absorption < 1% by Volume as per ASTM D 2842, Oxygen Index of 24.1 to 28.1 listed as per ASTM D 2863, cell size 0.4mm of dia ( max) as per ASTM D 3576. Fire retardant property as per DIN 4102 Part 1 of class B2 and as per ASTM E 84 Class A.

### 26.11.2 Installation Process

1. The Cavity Wall Insulation system has to be installed by the Trained and authorized Applicator Only.
2. The insulation board has to be installed from Inside of the wall and should be firmly struck with the help of water based adhesive applied on all the four sides of the Insulation Board.
3. The Struck insulation board should further be fixed with the help pf PVC fasteners, which has be fastened on all the four corners in such a way that it should hold adjoining insulation sheets as well.

### 26.11.3 Requirement for extruded polystyrene rigid insulation board (See Fig No.26.8)

Since this product of performance based product, the third Party testing is Mandatory and should be done from any NABL approved laboratory or from any NYLAP approved international laboratory. The requirements of tests as mentioned in table no.26.2

**Table 26.2**

| Sr. No | Requirement  | Test Standard     | Remarks   |
|--------|--|-------------------|-----------|
| 1      | Thermal Conductivity Having 180 days aged thermal conductivity of 0.0289 W/mk. | ASTM C 578        | Mandatory |
| 2      | Compressive strength of > 350 KPA.   | ASTM D 1621       | Mandatory |
| 3      | Density of 34-36 kg/Cum.   | ASTM D 1622       | Mandatory |
| 4      | Water absorption < 1% by Volume.   | ASTM D 2842       | Mandatory |
| 5      | Oxygen Index of 24.1 to 28.1   | ASTM D 2863       | Mandatory |
| 6      | Cell size 0.4mm of dia (max).  | ASTM D 3576       | Mandatory |
| 7      | Fire retardant property as per DIN , Part 1 of Class B2                        | -----             | Mandatory |
| 8      | Fire retardant property.   | ASTM E 84 CLASS A | Mandatory |

### 26.11.4 Measurements

Length and breadth of the wall insulation shall be measured correct to a cm and the surface area worked out in square metre of the finished work.

### 26.11.5 Rate

The rate shall include the cost of all materials and labour involved in all the operations described above including scaffolding if any required

## 26.12 UNDER DECK INSULATION SYSTEM

### 26.12.1 MATERIALS

50mm thick extruded polystyrene rigid insulation board of required size for Underdeck Insulation System, complying with ISO 4898:2008 & ASTM C 578-08b-type VI, having thermal conductivity of 0.0289 W/mk as per ASTM C 578 (Measured as per IS 3346), Compressive strength of > 350 KPA listed as per ASTM D 1621, density of 34-36 kg/Cum as per ASTM D 1622, Water absorption < 1% by Volume as per ASTM D 2842, Oxygen Index of 24.1 to 28.1 listed as per ASTM D 2863, cell size 0.4mm of dia (max) as per ASTM D 3576. Fire retardant property as per DIN , Part 1 of Class B2 and as per ASTM E 84 Class A.

### 26.12.2 Installation Process

1. The specified Under Deck Insulation System shall be applied by an Authorized applicator only.
2. The level of the slab should be checked and kept within permissible limit of variation of 3 to 5mm.
3. The Substrate/Roof Underdeck on which the insulation system needs to be installed must be free from all waste products such as petroleum, grease, oil, solvents, vegetable or mineral oil, animal fat etc.
4. The Insulation board must be fixed to the concrete slab from inside with the help of water based adhesive and Fasteners with PVC Capping. This has to be ensured that the PVC screws are embedded in the concrete with a minimum distance of 50mm from the edges and have a pull out strength of 0.3 kN.

### 26.12.3 Requirement for extruded polystyrene rigid insulation board (Fig.26.9)

Since this product is a performance based product, the third Party testing is Mandatory and should be done from any NABL approved laboratory or any other accreditation body which operates in accordance with test ISO/IEC 17011 and accredits labs as per ISO/IEC-17025 for testing. The test requirements as listed in table 26.3.

**Table 26.3**

| Sr. No | Requirement  | Test Standard     | Remarks   |
|--------|--|-------------------|-----------|
| 1      | Thermal Conductivity Having 180 days aged thermal conductivity of 0.0289 W/mk. | ASTM C 578        | Mandatory |
| 2      | Compressive strength of > 350 KPA.   | ASTM D 1621       | Mandatory |
| 3      | Density of 34-36 kg/Cum.   | ASTM D 1622       | Mandatory |
| 4      | Water absorption < 1% by Volume.   | ASTM D 2842       | Mandatory |
| 5      | Oxygen Index of 24.1 to 28.1   | ASTM D 2863       | Mandatory |
| 6      | Cell size 0.4mm of dia (max).  | ASTM D 3576       | Mandatory |
| 7      | Fire retardant property as per DIN , Part 1 of Class B2                        | -----             | Mandatory |
| 8      | Fire retardant property  | ASTM E 84 CLASS A | Mandatory |

### 26.12.4 Measurements

Length and breadth of the roofing insulation shall be measured correct to a cm and the surface area worked out in square metre of the finished work.

No deduction shall be made for openings of areas upto 0.40 square metre. No extra payment will be made for any extra material or labour involved in forming such openings. For openings exceeding 0.40 square metre in area, deduction for the full opening will be made, but no extra will be paid for any extra material or labour involved in forming such openings.

### 26.12.5 Rate

The rate shall include the cost of all materials and labour involved in all the operations described above including scaffolding if any required.

## 26.13 FACTORY MADE SOLID FOAM UPVC PROFILE FOR KITCHEN CABINET FRAME AND SHUTTER/PARTITION

### 26.13.1 Material

uPVC (un-plasticised polyvinyl chloride) is PVC resin blended with acrylic modifier, titanium dioxide and other chemicals. Then it is processed through machine and mould to produce required solid Foam uPVC multi-chambered profiles.

The factory made solid Foam uPVC white colour doors and windows shall be comprising of approved solid Foam uPVC make multi-chambered frames, sash and mullion duly reinforced with appropriate thickness of galvanised iron section of required length, an appropriate dimension of solid Foam uPVC glazing beads, EPDM gasket according to frame/sash profile and specified hardware and fittings of approved make having dimensions as per nomenclature of items. There are two type of solid Foam uPVC extruded profile series which are used depending upon the size and design of kitchen cabinet frame. Depth and width of the profile mentioned in the nomenclature of the item is as following.

- (i) **Depth of a profile (D)**- Dimension which is measured at right angles to the glazing plane, between the front and back face surfaces of a profile.
- (ii) **Width of a profile (W)**-Dimension, measured in the direction of the glazing plane, and perpendicular to the longitudinal axis of the profile.

### Tolerance in profile dimension

For solid Foam uPVC frame, sash and mullion extruded profile minus 5 % tolerance in dimension. i.e in depth and width of profile shall be accepted. Variation in profile dimension in higher side shall be accepted but no extra payment on this account shall be made.

#### 26.13.2 Terminology

**(a) Frame**

Non movable or fixed portion of the kitchen cabinet frame and shutter/Partition attached to the wall and to which the sash is assembled.

**(b) Sash**

Movable part in a kitchen cabinet frame and shutter/Partition.

**(c) Glazing Bead**

Profile which holds the glass or any other partition materials.

**(d) Transom (or Mullion)**

Profile used within the frame, vertically or horizontally in a frame and/ or sash.

#### 26.13.3 Marking

Solid Foam uPVC profiles shall be legibly and visibly marked in an unobtrusive position not visible when the window is closed at least once every one meter along the length of the profile and it should be visible when the window is open as well as shall contain the following minimum information on the main profile such as frame, sash and mullion/transom.

(i) The name of the trade mark or brand name of the manufacturer

(ii) Date of manufacturing and profile code

#### 26.13.4 Testing (Criteria for conformity)

The Solid Foam uPVC extruded hollow profiles use in kitchen cabinet frame and shutter/ Partition shall conform to the specification as per EN 12608 and other standards as mentioned in table 26.4

**Table 26.4**

| S.No | Name of the test   | Test Method    | Specified Parameter   |
|------|--|----------------|---|
| i)   | Vicat Softening Temperature  | EN ISO – 306   | Shall not be <750C  |
| ii)  | Charpy Impact Strength   | EN ISO – 179-2 | Shall not be <20KJ/m <sup>2</sup>                                       |
| iii) | Flexural Modulus Elasticity  | EN ISO – 178   | Shall not be <2200 N/mm <sup>2</sup>                                    |
| iv)  | Tensile Impact Strength  | EN ISO – 8256  | Shall not be <600 KJ/m <sup>2</sup>                                     |
| v)   | Mean Breaking Stress for welded corner<br>a) For the tensile bending test<br>or<br>b) For the compression bending test | EN – 514       | Shall not be <25 N/mm <sup>2</sup><br>Shall not be <30N/mm <sup>2</sup> |
| vi)  | Heat Reversion Test  | IS:4985-2000   | Shall not be > 2.0 %  |

For the determination of the weld ability of profiles, welded corners shall be tested for tests as mentioned above. The sample subjected to weld test shall not be finished by grooving and knifing etc. except for the outside edge of 90 degree angle, which shall be cleaned to permit the sample to sit fully on to the support.

Minimum percentage of titanium dioxide content in Solid Foam uPVC profiles shall not be less than 7.00 percent and calcium carbonate content shall not be more than 10.00 percent.

The Solid Foam uPVC kitchen cabinet frame and shutter/Partition shall be factory fabricated by the approved manufacturer and installation work shall be carried out by them or their authorised vendor duly approved by the Engineer -in -charge.

#### **26.13.5 Configuration**

Indicative size and configuration of kitchen cabinet frame and shutter/Partition to be provided, same shall be specified in the item and figure included in the tender document.

#### **26.13.6 Fabrication**

- (i) According to the drawing, the required dimension and length of Solid Foam uPVC frame, sash and mullion profiles shall be mitred cut and reinforced with galvanised iron section of required length and thickness.
- (ii) All frame and sash profiles of kitchen cabinet frame and shutter/Partition shall be fusion welded at all corners. Mullion and Transom profiles shall also be fusion welded as per window / door design so as to prevent any ingress of water or air in the reinforcement chamber.
- (iii) Each corner and joints shall be neatly cleaned by removing all excess material. The weld shall be finished by grooving, knifing etc. at exposed welded portion only.
- (iv) The kitchen cabinet frame and shutter/Partition shall be designed and provided water drainage/ventilation slots in profile of frame, sash, transom or mullion in order to permit the escape of entrapped water, moisture from the system. A minimum of 2 nos slots shall be provided at least at every 500 mm. The drainage shall be so designed as not to puncture the reinforcement chamber and prevent water running through the reinforcement chamber. The holes and slots shall offset between the inner and outer walls so as to prevent any back flow.

#### **26.13.7 Reinforcement**

- (i) The reinforcement material should be non-hygroscopic and should have no adverse effect of the performance of the kitchen cabinet frame and shutter/Partition and it shall conform to any grade of IS 1079 or IS 513.
- (ii) Mild steel section reinforcement made from Roll forming process and shall be hot dip zinc galvanised in accordance with IS 277 with a minimum coating mass of 120 gm/sqm.
- (iii) The thickness of reinforcement shall be as such that the Solid Foam uPVC kitchen cabinet frame and shutter/Partition meet the design wind pressure in accordance with IS 875 (Part-3) and design of the reinforcement should be as per Solid Foam uPVC profile manufacturer recommendation and fix to ensure adequate fastener retention.
- (iv) Galvanised mild steel reinforcement section is to be inserted in Solid Foam uPVC frame, sash and mullion profile of required length with in 6 to 15 mm distance from the face of the weld and then shall be screwed at 150mm from the end at every 400 mm (maximum) pitch to Solid Foam uPVC profile so that it does not move or rattle.

#### **26.13.8 Kitchen cabinet frame and shutter/Partition Hardware and Fittings**

Materials for all hardware except for fixing shall have at least the equivalent corrosion resistance of EN 1670-1988 grade 4 (240 hrs) when subjected to natural salt spray testing in accordance with EN ISO 9227. Testing shall be carried out on complete hardware items and also duly approved by the Engineer - in - charge before use at the site of work.

Hardware like hinges, rollers and locking devices which have been life cycle tested in accordance with EN 199 (Windows and Doors - Resistance to repeated opening and closing - Test method) and have achieved at least 10,000 operating cycles (i.e. opening and closing) without deterioration, failure or excessive wear.

These shall be provided as per nomenclature of item of approved make and duly approved by Engineer-in-Charge before fixing at site of work. Hardware / fittings such as handle, roller, touch lock, multipoint locking, 3D hinges, friction hinges etc. shall be directly screwed not pre-drilled or hammered.

#### **26.13.9 For kitchen cabinet frame and shutter/Partition**

Approved quality stainless steel friction hinges (SS 304 grade) with SS screws shall be provided as per nomenclature of item and length of friction hinges should cover more than 60 percent width of the shutter and two number friction hinges required for each shutter one at top and one at bottom.

#### **26.13.10 Tolerance**

The tolerance in dimensions of finished kitchen cabinet frame and shutter/Partition in size shall not be more than + 5mm from the approved drawing dimension.

#### **26.13.11 Installation**

- (i) There shall be a maximum gap of 3 to 5mm in between Solid Foam uPVC door / window frame and finished opening and the plastic packers shall be provided to maintain the level.
- (ii) To maintain the exact dimension of door or window, the opening shall be checked for dimension and orthogonally using a prefabricated template. Any defect shall be made good by the agency at his own cost before fixing of door or window.
- (iii) The Solid Foam uPVC frames are to be fixed in prepared opening in the walls. kitchen cabinet frame and shutter/Partition shall be fixed into the aperture by drilling through the outer frame to the existing structure and shall use 100 x 8mm fasteners of approved make.
- (iv) The gap between Solid Foam uPVC kitchen cabinet frame and shutter/Partition and adjacent RCC/Brick/Stone cladding work shall be filled with weatherproof Silicon sealant of approved make to maximum 5mm depth and 5mm in width to allow expansion/contraction of Solid Foam uPVC profiles. Silicon sealant of matching colour of Solid Foam uPVC profile shall be applied over backer rod.

#### **26.13.12 Precautions taken before installation of Solid Foam uPVC kitchen cabinet frame and shutter/Partition**

- (i) Jambs, sills and soffits of the opening shall be finished with plaster / stone / tiles according to agreement where Solid Foam uPVC kitchen cabinet frame and shutter/Partition to be fixed.
- (ii) Aperture shall be smooth in line and level as well as in plumb.
- (iii) Flooring (where kitchen cabinet frame and shutter/Partition is to be installed should be complete before installation of door).
- (iv) Installation of Solid Foam uPVC kitchen cabinet frame and shutter/Partition should be done before the last coat of the paint on the wall where window jambs, sills and soffits to be finished by paint. Atleast one coat of paint should be done before installation begins.
- (v) The colour of the profile shall be same and uniform on any surfaces or part of the surfaces which may be visible after installation of the kitchen cabinet frame and shutter/Partition fabricated from the profile, when viewed by the normal vision.



- (vi) The Solid Foam uPVC profiles manufacturer shall provide warranty of 10 years for colour fastness and any manufacturing defects in respect of Solid Foam uPVC profiles as well as water and air tightness in case of casement Solid Foam uPVC kitchen cabinet frame and shutter/Partition unit.
- (vii) Solid Foam uPVC kitchen cabinet frame and shutter/Partition hardware and fittings manufacturer shall provide warranty of 10 years for any manufacturing defects.

#### **26.13.13 Mode of Measurement**

The length and width of the kitchen cabinet frame and shutter/Partition shall be measured from outer to outer face of the Solid Foam uPVC frame correct to a centimetre. Area shall be calculated in square meter nearest to 0.01 square metres.

#### **26.13.14 Rate**

The rate includes the cost of all labour, material and T&P involved in all the operations described above at all heights of the building. The cost of glass panes, wire mesh and silicon sealant shall be paid separately.

### **26.14 REINFORCED SOIL RETAINING WALLS USING GEOGRIDS**

#### **26.14.1 General**

The work shall include the design and construction of reinforced soil structures using geogrids. Geogrids are defined as ***a geosynthetic reinforcement material consisting of connected parallel sets of polymeric tensile ribs with apertures of sufficient size to allow strike-through of surrounding soil, aggregate or other particulate matter.*** The ribs are called *longitudinal* and *transverse* respectively, depending on the direction of major stress. The connection points of the longitudinal and transverse ribs are called *junctions / nodes*. The openings in the geogrids, which are usually, square, rectangular or oval, are called apertures.

The primary function of geogrid is soil reinforcement. In those applications where the direction of major stresses are known, like reinforced walls & embankments, reinforced slopes, etc. *unidirectional* or *uniaxial geogrids* are used. In applications where the stresses come from random directions in the plane of the geogrid, *bidirectional* or *biaxial* grids are used. In addition, geogrids having three sets of ribs, at 120° to each other, where strength is balanced along the three rib directions, are also available. These are called triaxial geogrids, and may be used if the situation so demands.

In essence geogrids are of three types from the point of view of manufacturing process :

- (a) Extruded Polyethylene (PE) or Polypropylene (PP) (uniaxial, biaxial or triaxial)
- (b) Coated yarn of Polyester (polyethylene terephthalate-PET) or Polyvinyl Alcohol (PVA) coated with PVC or latex or Bitumen or any such similar coating for purpose of environmental protection). The entanglement of the yarn at the nodes is an important parameter which varies from product to product (unidirectional or bidirectional) for providing dimensional stability to the product.
- (c) High tenacity PET or PP straps or rods are overlapped longitudinally and transversely and the junctions are ultrasonically or laser bonded to form stable geogrids (unidirectional or bidirectional).

**This specification does not cover the soil reinforcement works executed with metallic reinforcement, or with geotextiles as reinforcement or natural fibre (coir or jute or bamboo) reinforcement materials or with Geoweb / geocells.**

**It also does not cover ‘Hybrid’ systems, where multiple/ more than one type of reinforcement product /system is used within the same structure.**

Geogrids are used in the following applications :

- (a) Sub-base / Foundation reinforcement
- (b) Erosion control
- (c) Reinforced Soil Walls and Slopes

(a) *Sub-base / Foundation reinforcement :*

Geogrids for use as reinforcement of sub-base of pavements or foundations shall be biaxial grids and shall meet the requirements listed in Table 26.5 :

**Table 26.5**

| Property                         | Unit | Stipulation                              | Test Method   |
|----------------------------------|------|--|---------------|
| Stiffness @0.5% strain           | kN/m | ≥ 350; both in MD and X-MD               | ISO 10319     |
| Tensile strength @2% strain      | kN/m | ≥ 15% of $T_{ult}$ ; both in MD and X-MD | ASTM D 6637   |
| Tensile strength @5% strain      | kN/m | ≥ 20% of $T_{ult}$ ; both in MD and X-MD | ASTM D 6637   |
| Junction efficiency for extruded | %    | ≥ 90% of rib ultimate tensile strength   | ASTM WK 14256 |
| Ultra-violet stability           | %    | ≥ 70% after 500 hrs exposure             | ASTM D 4355   |

**Note :** MD – Machine direction during manufacture

X-MD – Cross Machine direction during manufacture

All numerical values in the above Table represent MARV in the specified direction.

*Minimum Average Roll Value (MARV) :*

*At least 6 sample rolls are taken from each lot of supply. “Lot” is defined by each quantum of continuous supply or each quantum of continuous manufacture, whichever is less OR as agreed between Engineer-in-Charge and contractor. From each of the rolls of material, at least 8 specimen are taken and tested for the required property. The arithmetic average over all specimen are calculated for each roll (average roll value). The minimum of the averages denotes MARV.*

Statistically, MARV is 2 standard deviations less than the mean of average roll values. If the lot comprises more than 216 rolls, the number of samples should be  $\sqrt{N}$  (No. of rolls).

(b) *Erosion control:*

Detailed specifications for erosion control systems with geogrids shall be worked out as per manufacturer’s specifications for the system adopted.

(c) Reinforced Soil Walls and Slopes :

Structures with faces steeper than  $70^\circ$  are considered as reinforced soil walls (RSW) (or mechanically stabilized earth walls) and structures with face inclinations  $< 70^\circ$  are considered to be reinforced soil slopes (RSS). Some kind of fascia system will be required for walls and slopes steeper than  $45^\circ$

All reinforced soil walls or slopes shall be executed based on approved designs and drawings by the technical sanction authority. In case of EPC contracts, all generic specifications for reinforced soil walls or slopes, to the extent deemed fit by NIT approving authority, shall be made part of the tender document.



All reinforced soil walls and slopes having fascia elements require connections between reinforcing elements and fascia. The design of fascia including architectural / aesthetic considerations shall be made part of the tender documents. Similarly, different manufacturers / vendors /solution providers propose different forms of soil reinforcement to fascia connectors. The strength, elongation at load and durability of the connection shall be ascertained and generic requirements made part of the tender document. The performance guarantee of the system as a whole shall inter alia include the performance of fascia and connectors.

In case of geonet or geocomposite drainage system provided in reinforced soil retaining walls or slopes, the specifications for the same shall be provided separately as per the drainage requirement and system adopted, based on manufacturer's specifications. Guidance may be taken from ASTM STP 1390 "Testing and Performance of Geosynthetics in Subsurface Drainage". The different patterns of Geo grids as shown in Fig 26.10, 26.11 and 26.12.

**Reference may be made to IRC: SP:102-2014 "Guidelines for Design and Construction of Reinforced Soil Walls" for guidance on design principles, construction issues, quality control and common causes of failure of reinforced soil walls.**

## **26.14.2 Physical and Mechanical Properties of Geogrids**

### **26.14.2.1 General Requirements**

The physical dimensional properties of the reinforcing elements like type of structure, rib/strap dimensions, junction type, spacing between rib/strap, thickness of reinforcement elements, which vary from product to product, can be readily measured for compliance with manufacturer's specifications / data sheet. Some physical properties like mass per unit area, roll width and length, weight of roll, etc. impact the logistical issues like truckability, wastage, etc.

The manufacturers of geogrids shall have ISO – 9001 certification for manufacturing process and quality control.

The product proposed to be used in the work shall have certification for use as soil reinforcing material from an agency accredited for certifying geosynthetic reinforcement product.

The polymers used in the manufacture of soil reinforcing geogrids shall be virgin material.

The manufacturer shall provide third party test reports from NABL (or Geosynthetic Accreditation Institute – Laboratory Accreditation Program [GAILAP]) accredited laboratories in India for quantity of geogrids beyond a limit to be specified in the Notice Inviting Tender. The said limit will depend on quantum of work, its location, urgency, availability of accredited laboratories, etc. For all quantities less than that, manufacturer's test certificate shall suffice. Test reports from IITs shall also be acceptable. In case of one laboratory not having the entire gamut of facilities, different tests may be got done from separate tests facilities.

### **26.14.2.2 Physical Properties**

Density of the PE, PP, PET or PVA material of extruded geogrids or bonded strap geogrids can be measured using ASTM D 792 or ASTM D 1505. Coated PET yarn geogrids shall have molecular weight (ASTM D 4603) not less than 25000 gm/mol (minimum) and Carboxyl End Group Content (ASTM D 7409) which should not exceed 30 mmol/kg (maximum).

### **26.14.2.3 Engineering Properties of Geogrid**

The following engineering properties are required to be provided for all types of geogrids intended to be used in the work :

- (i) Wide width tensile strength (ASTM D 6637 or ISO 10319) : This is the Short term strength or characteristic strength ( $T_{CHAR}$ ) or ultimate tensile strength ( $T_{ULT}$ ). It is taken as the MARV strength i.e. mean strength less two standard deviations. Test for the ultimate tensile strength shall be carried out for each grade of reinforcement. The test results shall be accompanied by stress – strain curves showing strength at 2 % and 5% strain and strain elongation at failure.

- (ii) Endurance properties denoted by the various reduction factors : The manufacturer shall provide third party test reports from above mentioned laboratories / IITs for all the tests needed to establish all the reduction factors listed below :

$RF_{CR}$  - Reduction factor for creep

$RF_{ID}$  - Reduction factor for installation damage

$RF_W$  - Reduction factor for weathering

$RF_{CH}$  - Reduction factor for chemical / environmental effects

$f_s$  - Factor for the extrapolation of data. It caters to the statistical variation in the reduction factors but does not consider the uncertainties of soil structure and calculation of loads.

All the above factors shall be determined in accordance with the provisions of ISO/TR 20432 – “Guide to the determination of long term strength of geosynthetics for soil reinforcement”.

The Long Term design strength (LTDS) is determined as :

$$T_D = T_{CHAR} / R; \text{ where } R = RF_{CR} \times RF_{ID} \times RF_W \times RF_{CH} \times f_s$$

- (iii) Junction efficiency is defined as a percentage of junction strength determined in accordance with ASTM D 7737 and single rib failure strength as per ASTM D 6637. It varies between 90 to 100% for extruded biaxial grids, 10 to 25% for woven or knit grids and 40 to 70% for bonded strap grids.

For extruded biaxial or triaxial geogrids, the junction efficiency shall be  $95\% \pm 2\%$

#### **26.14.2.4 Project Specific Tests :**

Annual average Daily Temperatures (AADT) / design temperature of the project site shall be worked out and values of reduction factor for creep  $RF_{CR}$  and for  $RF_{CH}$  shall be provided as per procedures given in ISO / TR -20432.

Also Tests shall be carried out to provide the following parameters for all grades of geogrids used in the project :

- (a) Pull-out coefficient as per ASTM D 6706 “Standard Test Method for measuring Geosynthetic pullout Resistance in Soil” and;
- (b) Coefficient of interaction between reinforced fill soil and geogrids as per ASTM D 5321 – “Standard Test Method for Determining the coefficient of soil and Geosynthetic or Geosynthetic and Geosynthetic Friction by the Direct Shear Method” or as per IS :13326 : Part 1 – 1992 “Method of test for the evaluation of interface friction between Geosynthetic and soil : Part 1 Modified direct shear technique”.

One set of project specific tests shall be conducted at field or third party accredited laboratory or at any reputed institute like IITs, which may be mentioned in the tender.

#### **26.14.3 Engineering Properties of Earth Fill**

The fill material in the reinforced soil zone shall have drained or effective angle of friction not less than  $30^\circ$ , measured in accordance with IS :2720 (Part 13), by conducting a drained direct shear test. In case the fill material has 25 percent or more particles of 4.75 mm or larger, drained shear test using large shear box may be conducted (IS :2720 : Part 39 : Section 1).

The Plasticity Index of the fill material shall be  $\leq 6$ .

The gradation of fill soil shall be as per limits specified in Table 26.6

Table 26.6

| Sieve Size | Percentage Passing |
|------------|--------------------|
| 75 mm      | 100%               |
| 425 micron | 0 – 60%            |
| 75 micron  | < 15%              |

Materials with more than 15 percent passing 75 micron sieve, but less than 10 percent of particles smaller than 15 microns are acceptable provided Plasticity Index (PI) is less than 6 and angle of internal friction ( $\phi$ ) is not less than 30°.

Where Geosynthetic reinforcement material used is polyester yarn, the pH value of the fill material shall be between 3 and 9. For Geosynthetic reinforcement material manufactured from PVA, PP and HDPE, the pH value of the fill material shall be greater than 3. The pH value of the soil fill shall be determined as per IS : 2720 (Part 26) – 1987 (Reaffirmed 2016)

Fly ash may be used as fill materials in reinforced soil walls provided its angle of internal friction ( $\phi$ ) is not less than 30° and PI is less than 6. Reference may be made to IRC Guide lines on Use of Fly ash in Road Embankments (IRC:SP-58).

Fly ash shall also satisfy requirements concerning pH values as above.

The fill materials used in the reinforced soil zone shall be free from organic or other deleterious materials and shall not react adversely (chemically, electrically or biologically) with the reinforcement material and / or facia material.

Properties of fill soil in the reinforced zone, unreinforced zone (or retained / back fill) soil and the foundation soil shall be determined accurately during the construction phase, as per quality assurance plans and directions of Engineer-in-Charge so as to ensure that these are the same as those considered in the design.

The fill soil in the unreinforced zone shall also conform to the requirements specified in the design.

**26.14.4 Identification, Transportation, Storage and Handling**

Geogrids shall be procured in roll form of width as per design requirement and with the prior approval of the Engineer-in-Charge. All rolls shall have a protective cover with a label or tag (at multiple locations and inside the core of the rolls in accordance with ASTM D 4873) specifying name of the product, name of the manufacturer, roll number, date of manufacture and roll dimensions.

Material shall be protected from sunlight, mud, dirt, debris, any other harmful substances or mechanical damage during transportation.

Rolls shall be stored in a secured area sufficiently elevated above the ground and adequately covered to protect them from the following: Construction site damage, precipitation, prolonged exposure to ultraviolet radiation including sunlight, chemicals that are strong acids or strong bases, flames including welding sparks, high temperatures, and any other environmental conditions that may damage the physical property values of the Geogrid.

Any material, which is damaged during transportation, handling or storage and do not meet the minimum requirements of the specifications, rendering it unsuitable for use in the specific application, is liable for rejection by the Engineer-in-Charge.

### **26.14.5 Failure Definition, System Responsibility and Performance Bond**

The design life, performance criteria and failure definitions shall be as per FHWA-NHI-10-024 and IRC : SP : 102-2014. The design of reinforced soil wall or slope shall spell out the design life, performance criteria and failure definitions. For example, the deformations of the wall / slope or any component thereof exceeding the design values, any visible structural distress in any wall element, any subsidence of the top surface of reinforced soil leading to distress in the infrastructure which is structurally dependent on the reinforced soil wall or slope or foundation system, etc. are some conditions to be watched.

The decision of the Engineer-in-Charge as to the failure or otherwise of the reinforced soil wall or slope or foundation system shall be final and binding on the contractor.

In case of failure, approved retrofitting measures may be adopted, duly vetted by expert institutions like IITs, at the risk and cost of the contractor. The retrofitting measure shall be approved by the Engineer-in-Charge.

Alternatively, and as a last resort, the whole or part of the structure, which has failed, shall be dismantled and redone to the entire satisfaction of the Engineer-in-Charge.

If specified in the contract, the reinforced soil system performance shall be covered under performance guarantee of the entire work, and no separate defect liability period or bond need be specified for the reinforced soil structure. However, corporate guarantee for system performance for a period covering the Defect Liability Period or more may be sought from the contractor.

### **26.14.6 Installation & Measurement for Payment**

#### **26.14.6.1 Site Preparation**

The site shall be prepared by clearing, grubbing, and excavation or filling the area to the design grade. This includes removal of topsoil and vegetation.

#### **26.14.6.2 Foundation:**

The foundation shall be a leveling pad of minimum 100mm width over and above the width of the fascia element, and 150mm thick M10 grade plain concrete, provided at a depth not less than 1000mm to receive the fascia elements and / or bottom most layer of reinforcement. The designer may provide higher specifications if the situation at site so demands.

#### **26.14.6.3 Laying of Geogrid**

The geogrid shall be laid perpendicular to the face of the wall with greater cross sectional dimension in the horizontal plane. The geogrid shall be laid stretched and smooth without wrinkles or folds on the prepared subgrade (or within the granular subbase / base course if shown in the drawings) with the machine direction oriented in the direction of major stress or as shown in the drawings. It shall be held taut by suitable arrangement at site.

Geosynthetic uniaxial reinforcement shall be placed in continuous longitudinal rolls in the direction of the main stress. Joints parallel to the wall shall not be permitted, except as shown on the working drawings. Reinforcement coverage shall be a given percent of embedment area to be mentioned in the design / working drawings, as per the type of reinforcement being used. Adjacent sections of geosynthetic reinforcement need **not** be overlapped or mechanically connected. In case of biaxial / triaxial reinforcement applications, overlap / connections shall be as per manufacturer's requirements.

On curves, the geogrid may be folded or overlapped to conform to the curves. The fold or overlap shall be in the direction of construction and held in place by pins, staples, etc.

Prior to placing sub base / base course material the installed geogrid shall be inspected and approved by the Engineer-in-Charge. Any minor damages shall be repaired by covering the damaged location with a geogrid patch, which shall be mechanically connected to the parent reinforcement, as directed by the Engineer-in-Charge.

#### 26.14.6.4 Placing and Compacting Sub base/base course

The sub base or base shall be placed by end dumping onto the geogrid from the edge of the geogrid or over previously placed sub base or base aggregate. The dumper shall move in reverse direction over the spilled material.

Movement of construction equipment directly over the geogrid shall not be permitted. The grid shall have a minimum compacted thickness of 150 mm over the grid before allowing movement of vehicles, the speed of which shall be limited to 10 km/hr.

Sudden breaking and sharp turning of construction equipment shall be avoided on the first lift of earth over the geogrid.

#### 26.14.6.5 Specifications for Facia

The facing system shall be one of the following :

(a) **Precast reinforced concrete panels:**

The minimum thickness of precast concrete panels shall be 180 mm including facing textures, logos and embellishments. The grade of concrete shall be minimum M35. The concrete shall conform to the requirements of IS 456-2000.

Facia panel systems shall have provision of both horizontal and vertical gaps to prevent concrete to concrete contact. The horizontal gap between the facing elements shall be maintained by provision of Ethylene Propylene Diene Monomer (EPDM) pad.

The joints between the panels shall be covered from inside (inner face side) with non-woven geotextile strips glued to the facing element ensuring full coverage of joints, to prevent loss of aggregate filter material. Synthetic glue shall be used for this purpose. The width of the geotextile strip shall not be less than 100 mm. This provision of covering of panel joints with geotextile strips need not be followed if Geocomposite filter is used in place of aggregate filter media.

All dimensions of the RCC panel facia elements shall be within  $\pm 5$ mm, except thickness for which tolerance shall be (+)5mm & (-) 0mm. Additionally, the evenness of the front face shall be  $\pm 5$ mm over 1500 mm length. The difference between length of the two diagonals shall not be more than 5mm.

(b) **Precast concrete interlocking blocks or Precast concrete hollow blocks:**

Precast concrete blocks are dry cast and shall be manufactured from fully automatic block making machines. The minimum grade of concrete shall be M 35 for all kinds of modular blocks. In case of hollow blocks, the hollow area shall not exceed 40 percent of the cross sectional area of the block. The outer side of the block shall have minimum thickness of 100mm. The hollow area shall however be filled with filter media.

The dimensional tolerance for length and width shall be  $\pm 2.5$ mm and for height  $\pm 1.5$ mm.

(c) **Gabion facing:**

Where gabion facia is used, it shall conform to the provisions of BS – 1:2010 and EN 14475 and made of mechanically fabricated double twisted hexagonal mesh. Wire used for the double twisted mesh and selvages shall be hot dip galvanized as per IS : 4826 – heavily coated and soft type, with wire and mesh properties in accordance with EN – 10223 with minimum Zn + alloy coating as per EN – 10244 and 0.5 mm thick PVC coating as per EN – 10245 and ISO – 527.

(d) **Wrap around facia using geotextiles:**

Where geosynthetics, including geogrids are used as wrap around facia, these shall form a part of the reinforcing element. The wrap around shall have adequate length to resist pull out and the wrap around length shall be calculated on the basis of safety in pull out. Wrap around facia shall be protected by suitable means, against adverse effects of UV and other elements of nature.

(e) *Other proprietary and proven systems at the discretion of NIT approving authority*

The facing material as well as the connections between facia and reinforcement shall be sufficiently flexible to withstand any deformation of the fill and foundations.

The facia shall have an inward batter as shown in the drawings so that the tendency of the facia panels to bulge outwards is countered.

Facia type adopted shall be given in the design and shown with complete details in the drawings. The system supplier shall provide any test data to satisfy the Engineer-in-Charge regarding the properties and suitability of the facia system adopted, if so required.

Where facia such as wrap around or gabion or welded wire and woven steel wire mesh facings have been used and where climate conditions are appropriate, a green finish may be provided where specified.

#### **26.14.6.6 Connection between the Facia And Reinforcement**

Connection between the facia panels and the reinforcing element shall be by using either nut or bolt, HDPE inserts with bodkin joint, hollow embedded devices, polymeric/galvanized steel strips, / rods, / pipes, / loop & toggle, fiber glass dowels or any other material shown in the drawings. The connection between the panel and the reinforcement shall provide for 100 percent of the long term design strength of the reinforcing element in continuity. Proprietary connections systems may be provided as per design, subject to the condition that they are compliant with the design requirements and durable.

In case of modular block facia and other type of facia such as gabion facia, where the reinforcement is held by friction between the facia block and the reinforcement, the connection strength shall be determined as per ASTM D 6638 :Standard Method of Test for Determining Connection Strength between Geosynthetic Reinforcement and Segmental Concrete Units".

The available connection strength shall satisfy the design requirements and shall not be less than the maximum possible tensile force that the reinforcement layer under consideration may be subjected to.

#### **26.14.7 Measurement for Payment & Rates**

##### **(i) Reinforced Soil Wall :**

The measurement for payment for reinforced soil wall shall be in square meters of finished work of each face and shall be measured in the plane of final inclination specified in the drawings. The measurement of length shall be the finished work along the length of the road. The measurement of height along the slope shall be done from the top level of the footing on which the facia element is placed to the top of the capping beam.

Measurement for friction slab and crash barrier shall be made separately.

##### **(ii) Reinforced Soil Slope :**

The measurement for payment for reinforced soil slope shall be in square meters of finished work of each face and shall be measured in the plane of final inclination specified in the drawings. The measurement of height along the slope shall be done from the top of the leveling pad, where provided, to the top of the embankment. Where leveling pad is not provided, the height shall be measured, in the final plane of inclination specified in the drawings, from the bottom of the slope face to the top of topmost facing element provided.

Measurement and payment of friction slab and crash barrier if provided shall be made separately.



(iii) Rates:

The rate shall include cost of material, labour, plant and machinery, royalties, handling, storage and transportation expenses, leveling pad, fascia elements, coping beam, connectors, reinforcing elements, scaffolding, all inclusive EXCEPT supply and installation of the specified filter media material, bed block, supply of soil fill for the reinforced as well as unreinforced zone of the quality specified in the contract, placing, spreading and compaction through mechanical means, which shall be measured separately.

No separate measurements for overlaps, wastages, or on any other account shall be admissible, unless specifically provided for in the tender.

The rate shall include full compensation for design, drawings and testing of materials, as per tender conditions.

The rate shall NOT include the cost of investigations, design and construction of ground improvement measures, if required. The same shall be provided and paid as per NIT.

The payment for friction slab and crash barrier shall be made separately.

**26.14.8 Design and Drawings:**

The design of reinforced soil structure, the same shall be carried out in accordance with the following standards as applicable :

- (i) BS:8006-1-2010 “Code of Practice for Strengthened /Reinforced Soils and other Fills”.
- (ii) IRC:SP:102-2014 “Guidelines for Design and Construction of Reinforced Soil Walls”.
- (iii) FHWA – NHI-10-024 and FHWA – NHI-10-025 – “ Design and Construction of

Mechanically Stabilized Earth Walls and Reinforced Soil Slopes”

The design shall include the design of drainage system for the reinforced soil wall or slope or foundation system.

**26.14.9 Quality Control and Testing**

The quality management system of the manufacturer shall conform to the requirements of ISO 9001:2015.

Manufacturer shall issue a test report stating minimum average roll values of material properties, at the time of shipment from factory.

CE-certification should be required for supply of polymer geogrid material.

Manufacturer shall submit proof of having supplied to –

- (i) One project in India having at least 80% of the tender quantity, OR
- (ii) Two projects in India having at least 60% of the tender quantity, OR
- (iii) Three projects in India having at least 40% of the tender quantity

The manufacturer shall submit project references if required by the Engineer-in-Charge.

In addition, at least one of the above qualifying projects shall have performed satisfactorily for at least a 5-year period. Owner / Engineer’s certificate to that effect shall be submitted.

**The NIT approving authority may, for recorded reasons, alter the above specifications due to exigencies of work.**

## 26.15 ALUMINUM PROFILE INDUSTRIAL TROUGHED SHEET ROOFING

### 26.15.1 MATERIALS

#### 26.15.1.1 Aluminum profile industrial troughed sheet

These shall be made of alloy 31500/ 31000/40800 of thickness specified in the description of the item and Chemical Composition of Wrought Aluminium and Aluminium Alloy Sheet and Strip shall conform to IS 737. The weight of the sheet shall not be less than the value as per table 26.7.

**Table 26.7**

| Thickness (mm) | Weight of Sheet (Kg) |                  |             |
|----------------|----------------------|------------------|-------------|
|                | Per Sqm. Sheet       | Per metre Length |             |
|                |                      | 920mm wide       | 1044mm wide |
| 0.91           | 3.23                 | 2.96             | 3.36        |
| 0.71           | 2.50                 | 2.31             | 2.62        |

The sheets shall be free from cracks, split edges, twists, surface flaws etc. They shall be clean, bright and smooth. The sheets shall not show signs of rust or white powdery deposits on the surface. The corrugations shall be uniform in depth and pitch and parallel with the side.

#### 26.15.1.2 Purlins

Purlins of the specified material or M.S. rolled sections of requisite size shall be fixed over the principal rafters. These shall not be spaced at more than the following distances. (Table 26.8)

**Table 26.8**

| Thickness of sheet | Maximum spacing of purlins (intermediate) | Maximum spacing of purlins (ends) |
|--------------------|---|-----------------------------------|
| 0.71 mm            | 0.80 metre                                | 0.55 metre                        |
| 0.91 mm            | 1.20 metre                                | 0.80 metre                        |

The unsupported overhang sheets should not be more than 100mm and 150mm for the sheet thickness of 0.71mm and 0.91mm respectively. The top surfaces of the purlins shall be uniform and plane. They shall be painted before fixing on top. Embedded portions of wooden purlins shall be coal tarred with two coats.

#### 26.15.2 Slope

Roof shall not be pitched at a flatter slope than 1 vertical to 6 horizontal. The normal pitch adopted shall usually be 1 vertical to 4 horizontal.

#### 26.15.3 Laying and Fixing

The sheets shall be laid and fixed in the manner described below, unless otherwise shown in the working drawings or directed by the Engineer-in-Charge.

The sheets shall be laid on the purlins to a true plane, with the lines of corrugations parallel or normal to the sides of the area to be covered unless otherwise required as in special shaped roofs.

The sheets shall be laid with a minimum lap of 15 cm at the ends and 2 ridges of corrugations at each side. The above minimum end lap of 15 cm shall apply to slopes of 1 vertical to 2 horizontal and steeper slopes. For flatter slopes the minimum permissible end lap shall be 20 cm. The minimum lap



of sheets with ridge, hip and valley shall be 20 cm measured at right angles to the line of the ridge, hip and valley respectively. These sheets shall be cut to suit the dimensions or shapes of the roof, either along their length or their width or in a slant across their lines of corrugations at hips and valleys. They shall be cut carefully with a straight edge chisel to give a smooth and straight finish.

Sheets shall not generally be fixed into gables and parapets. They shall be bent up along their side edges close to the wall and the junction shall be protected by suitable flashing or by a projecting drip course, the later to cover the junction by at least 7.5 cm.

The laying operation shall include all scaffolding work involved.

Sheets shall be fixed to the purlins or other roof members such as hip or valley rafters etc. with fixed using self drilling/ self tapping SS screw (See Fig 26.13A & 26.13B) of size 5.5x65mm with EPDM seal complete upto required pitch in horizontal, vertical or curves surfaces.

When fastening with self-drilling fasteners, it is imperative that the screw point has cleared the substrate before the threads engage or the driller will actually pull the threads through the substrate faster than it can be drilled, thereby breaking the fastener.

The bolts shall be sufficiently long so that after fixing they project above the top of the nuts by not less than 10 mm. There shall be a minimum of three self drilling / self tapping placed at the ridges of corrugations in each sheet on every purlin and their spacing shall not exceed 30 cm.

The self drilling/ self tapping SS screw shall be continuous and free from defects such as blisters, flux stains, drops, excessive projections or other imperfections which would impair serviceability.

#### **26.15.4 Finish**

The roof when completed shall be true to lines, and slopes and shall be leak proof.

#### **26.15.5 Measurements**

The length and breadth shall be measured correct to a cm. Area shall be worked out in sqm correct to two places of decimal.

The superficial area of roof covering shall be measured on the flat without allowance for laps and corrugations. Portion of roof covering overlapping the ridge or hip etc. shall be included in the measurements of the roof.

Roof with curved sheets shall be measured and paid for separately. Measurements shall be taken on the flat and not girthed.

No deduction in measurement shall be made for opening upto 0.4 sqm and nothing extra shall be allowed for forming such openings. For any opening exceeding 0.4 sqm in area, deduction in measurements for the full opening shall be made and in such cases the labour involved in making these openings shall be paid for separately. Cutting across corrugation shall be measured on the flat and not girthed. No additions shall be made for laps cut through.

#### **26.15.5 Rate**

The rate shall include the cost of all the materials and labour involved in all the operations described above including all screws, seal, ridge, scaffolding, machinery for fixing and approved sealant where required etc. but excluding the cost of purlins, rafters and trusses.

## 26.16 ECO FRIENDLY LIGHT WEIGHT CALCIUM SILICATE FALSE CEILING (TEGULAR EDGED)

### 26.16.1 Materials

#### 26.16.1.1 Tiles

Eco friendly light weight calcium silicate tiles shall be made from Non-cementitious hydrated wet moulded calcium silicate slurry/mixture, reinforced with fibers and natural fillers. Free from formaldehyde and other harmful materials. Does not contain any toxic ingredients. Shall have appropriate recycled material contents.

The Ceiling Tiles shall be of appropriate class and of finished thickness as specified in the description of the item .Only selected tiles of uniform width shall be used. Unless otherwise specified in the description of the item or shown in the drawings, the width of tiles selected for use shall not be less than 595 X 595 mm in size and shall be 15 mm thick integral densified tegular edged type, light weight wet moulded calcium silicate.

Where width of room/ corridor is in multiple of standard width of tiles, same pattern shall be maintained throughout the length. Where the width of rooms/ corridor is not in multiple of standard width of tiles, borders with appropriate width and material of boards shall be provided in design approved by the Engineer-in-charge and maintained uniformly throughout of the length/ width of room/ corridor. Eco Friendly Light Weight Calcium silicate tiles shall have the following properties:

- (a) **Surface:** All tiles are prime coated on both sides. Standard finish in two coats white dispersion type, solvent free paint.
- (b) **Dimensions:**  
595mmx595mmx15mm thick tegular edged. Size referred to are always module sizes. The nominal panel size may differ depending on the suspension system used.
- (c) **Thickness:** 10 mm thick in the center and 15mm thick all around on edge resting portion with integral densified edge.
- (d) **Density of material:** 350 kg per cum in the central 10 mm thick portion and 450 kg cum on the edges, (Average 370 kg per cum as per ECBC Code 2007).
- (e) **Relative humidity:** 100% RH resistant.
- (f) **Fire resistance:** Non-combustible as per BS:476 Part-4. Fire performance: as per BS:476 (Part-6) for fire propagation and BS 476 (Part 7) for Surface spread of flame.
- (g) **Thermal conductivity:** 0.048 W/m- K - 0.052 W/m- K as per ECBC Code 2007 and ASTM 518-1991.
- (h) **Recycled Content:** Shall have 46-50% recycled content out of which 18-20% should be FLYASH.
- (i) **Acoustic control:** Sound Attenuation 30-32dB  
Noise reduction coefficient (NRC)  
Plain & Designer tile: 0.10-0.15.  
For Pin Hole/Texture pattern tiles: 0.20-0.30.  
Pin hole/Texture fully perforated tile: 0.30-0.40.  
For 5mm fully perforated 0.40-0.50.  
For 5mm fully perforated with 50mm/48gsm glass wool 0.65-0.85.

- (J) **Light reflectance:** >85%.
- (k) **Weight:** 5 - 5.5Kg/m<sup>2</sup>.
- (l) **Suspension system:** Suspension system shall be made of roll-formed hot-dipped galvanized steel.

#### 26.16.1.2 Frame

Frame is made up of interlocking metal T-grid of hot dipped galvanized steel sections of 0.33mm thick (Galvanized @ 120 gms/m<sup>2</sup> including all sides) comprising of main T runners of size 24 x 38mm of length 3000mm, cross T of size 24 x 32 mm of length 1200mm and secondary intermediate cross T of size 24 x 32mm of length 600mm to form grid modules of size 600 x 600mm. This grid shall be suspended from ceiling using galvanized mild steel members (Galvanized @ 80 gms/m<sup>2</sup> including all sides) i.e. 12x50mm long dash fasteners, 6mm dia fully threaded hanger rod upto 1000 mm length and L-shaped level adjuster of size 76 x 25 x 25x 1.6mm fixed with grid and Z cleat of size 25x37x25x1.6mm thick with precut hole on both 25mm flange to pierce into 12x50mm or even bigger dash fastener if require. Frame also consist of galvanized iron perimeter wall angle of size 24 x 24 x 0.40mm of length 3000mm to be fixed on periphery wall/ partition with the help of plastic rawl plugs at 450mm centre to centre and 40mm long wall SS screws.

The bottom surface of the frame shall be checked and corrected to true plans and slopes.

#### 26.16.2 Fixing

Outer wall angle shall be fixed accurately and truly at required height and level, parallel and close to the wall. Thereafter all the T members shall be placed and fixed carefully to form the grid. The grid comprises of main T-runners at 1200mm centres securely fixed to the structural soffit by approved and adjustable hanger rods at 1200mm maximum centres and not more than 150mm from spliced joints of main T-runners. The last hanger at the end of each runner should not be greater than 600mm from the adjacent wall. Similarly, cross T-runners of 1200mm length shall be placed at 600mm centre to centre. 600x600mm modules to be formed by fitting 600mm long flush fitting cross Tees (secondary cross T) centrally between 1200mm cross T-runners. The tiles shall then be placed properly in the grids as per required pattern, texture and design/ drawing and as per directions of the Engineer-in-Charge. If required, level of the false ceiling grid shall be checked after placing of calcium silicate tiles and necessary adjustment shall be made wherever required through level adjuster.

#### 26.16.3 Precaution:

- (a) All wet trades such as plastering, conduiting and painting etc, be completed prior to start of false ceiling works.
- (b) Air conditioning duct work is to be completed preferably even before the suspension of the grid section.
- (c) Electrical chasing or drawing lines & cables, etc are to be in place before start of false ceiling work.
- (d) No unauthorized weight is put on false ceiling. Lighting fixtures, diffusers are to be suspended independently with proper chain/wire & dash fasteners as directed by Engineer In Charge/ manufacturer guide line.
- (e) The area is dry prior to ceiling installation work.

#### 26.16.4 Finishing

Care should be taken while placing Light Weight calcium silicate tiles into the grid so that there will be no displacement to grid and stains/ dirty marks put by the workers. (worker should preferably wear clean soft cotton gloves while placing tile).

### 26.16.5 Measurements

Length and breadth shall be measured correct to a cm. Areas shall be worked out to nearest 0.01sqm. The superficial area of the finished work ceiling shall be measured in square meters. No deduction in measurements shall be made for openings of areas upto 0.36 Sqm. Nothing extra shall be payable either for any extra material or labour involved in forming such openings. For openings exceeding 0.36 sqm in area, deductions in measurements for the full opening in multiple of area of each tile (0.36 Sqm) will be made.

### 26.16.6 Rate

The rate shall include the cost of all materials and labour involved in all the operations described above.

**26.16.7 MTC:** Manufacturers test certificate/ report of invoice to be submitted for every delivery challan by suppliers.

## 26.17 ECO FRIENDLY LIGHT WEIGHT CALCIUM SILICATE FALSE CEILING (MICRO LOOK EDGE) (Fig . 16)

### 26.17.1 Materials

#### 26.17.1.1 Tiles

Eco friendly light weight calcium silicate tiles shall be made from Non-cementitious hydrated calcium silicate slurry/mixture, reinforced with recycled material and natural fillers. Free from formaldehyde and other harmful materials. does not contain any toxic ingredients.

Tiles shall be appropriate class and of finished thickness as specified in the description of the item. Only selected tiles of uniform width shall be used. Unless otherwise specified in the description of the item or shown in the drawings, the width of tiles selected for use shall not be less than 595 x 595mm in size and of approved texture, design and patterns and shall be 15mm thick integral densified micro-edged type light weight calcium silicate.

Where width of room/ corridor is in multiple of standard width of tiles, same pattern shall be maintained throughout the length. Where the width of rooms/ corridor is not in multiple of standard width of tiles, borders with appropriate width and material of boards shall be provided in design approved by the Engineer-in-charge and maintained uniformly throughout of the length/ width of room/ corridor. Calcium silicate tiles shall have the following properties:

- (a) **Surface:** All tiles are prime coated on both sides. Standard finish in two coats white dispersion type, solvent free paint.
- (b) **Dimensions:**  
595mm x 595mm x 15mm thick integral densified micro-edge. Size referred to are always module sizes. The nominal panel size may differ depending on the suspension system used.
- (c) **Thickness:** 10 mm thick in the center and 15mm thick all around on edge resting portion with micro look integral densified edge.
- (d) **Density of material:** 350 kg per cum in the central 10 mm thick portion and 450 kg cum on the edges, (Average 370 kg per cum as per ECBC Code 2007).
- (e) **Relative humidity:** 100% RH resistant.
- (f) **Fire resistance:** Non-combustible as per BS:476 Part-4. Fire performance: as per BS:476 (Part-6) for fire propagation and BS 476 (Part 7) for Surface spread of flame.

- (g) **Thermal conductivity:** 0.048 W/m- K - 0.052 W/m- K as per ECBC Code 2007 and ASTM 518-1991.
- (h) **Recycled Content:** Shall have 46-50% recycled content out of which 18-20% should be FLYASH.
- (i) **Acoustic control:** Sound Attenuation 30-32dB  
Noise reduction coefficient (NRC)  
Plain & Designer tile: 0.10-0.15.  
For Pin Hole/Texture pattern tiles: 0.20-0.30.  
Pin hole/Texture fully perforated tile: 0.30-0.40.  
For 5mm fully perforated 0.40-0.50.  
For 5mm fully perforated with 50mm/48gsm glass wool 0.65-0.85.
- (j) **Light reflectance:** >85%.
- (k) **Weight:** 5 - 5.5Kg/m<sup>2</sup>.
- (l) **Suspension system:** Suspension system shall be made of roll-formed hot-dipped galvanized steel.

#### 26.17.1.2 Frame

Frame is made up of interlocking metal pre coated T-grid of hot dipped galvanized steel sections of 0.40mm thick on Silhouette profile comprising of main T runners of size 15 x 42mm of length 3000mm, cross T of size 15 x 42mm of length 1200mm and secondary intermediate cross T of size 15 x 42mm of length 600mm to form grid modules of size 600 x 600mm. This grid shall be suspended from ceiling using galvanized mild steel members (Galvanized @ 80 gms/m<sup>2</sup> including all sides) i.e. 12x50mm long dash fasteners, 6mm dia fully threaded hanger rod upto 1000 mm length, L-shaped level adjuster of size 76 x 25 x 25x 1.6mm fixed with grid and Z cleat of size 25x37x25x1.6mm thick with precut hole on both 25mm flange to pierce into 12x50mm or even bigger dash fastener if required. Frame also consist of galvanized iron perimeter wall angle of size 22 x 19 x 0.40mm of length 3000mm to be fixed on periphery wall/ partition with the help of plastic rawl plugs at 450mm centre to centre and 40mm long dry wall SS screws.

The bottom surface of the frame shall be checked and corrected to true plans and slopes.

#### 26.17.2 Fixing

Outer wall angle shall be fixed accurately and truly at required height and level, parallel and close to the wall. Thereafter all the T members shall be placed and fixed carefully to form the grid. The grid comprises of main T-runners at 1200mm centres securely fixed to the structural soffit by approved and adjustable hanger rods at 1200mm maximum centres and not more than 150mm from spliced joints of main T-runners. The last hanger at the end of each runner should not be greater than 600mm from the adjacent wall. Similarly, cross T-runners of 1200mm length shall be placed at 600mm centre to centre. 600x600mm modules to be formed by fitting 600mm long flush fitting cross Tees (secondary cross T) centrally between 1200mm cross T-runners. The tiles shall then be placed properly in the grids as per required pattern, texture and design/ drawing and as per directions of the Engineer-in-Charge. If required, level of the false ceiling grid shall be checked after placing of calcium silicate tiles and necessary adjustment shall be made wherever required through level adjuster.

### **26.17.3 Precaution:**

- a. All wet trades such as plastering, conduiting and painting etc, be completed prior to start of false ceiling works.
- b. Air conditioning duct work is to be completed preferably even before the suspension of the grid section.
- c. Electrical chasing or drawing lines & cables etc are to be in place before start of false ceiling work.
- d. No unauthorized weight is put on false ceiling. Lighting fixtures, diffusers are to be suspended independently with proper chain/wire & dash fasteners as directed by Engineer In Charge/ Manufacturer guide line
- e. The area is dry prior to ceiling installation work.

### **26.17.4 Finishing**

Care should be taken while placing Light Weight calcium silicate tiles into the grid so that there will be no displacement to grid and stains/ dirty marks put by the workers. (worker should preferably wear clean soft cotton gloves while placing tile).

### **26.17.5 Measurements**

Length and breadth shall be measured correct to a cm. Areas shall be worked out to nearest 0.01sqm. The superficial area of the finished work ceiling shall be measured in square meters. No deduction in measurements shall be made for openings of areas upto 0.36 Sqm. extra shall be payable either for any extra material or labour involved in forming such openings. For openings exceeding 0.36 sqm in area, deductions in measurements for the full opening in multiple of area of each tile (0.36 Sqm) will be made.

### **26.17.6 Rate**

The rate shall include the cost of all materials and labour involved in all the operations described above.

**26.17.7 MTC:** Manufacturers test certificate/ report of invoice to be submitted for every delivery challan by suppliers.

## **26.18 ECO FRIENDLY LIGHT WEIGHT CALCIUM SILICATE WALL PANELLING (FULLY PERFORATED SQUARE/ BUTT EDGED) (Fig . 17)**

### **26.18.1 Materials**

#### **26.18.1.1 Tiles**

Eco Friendly Light Weight Calcium silicate tiles shall be made from Non-cementitious hydrated calcium silicate slurry/Mixture, reinforced recycled material with fibers and natural fillers. Free from formaldehyde and other harmful materials. Does not contain any toxic ingredients.

Tiles shall be appropriate class and of finished thickness as specified in the description of the item. Only selected tiles of uniform width shall be used. Unless otherwise specified in the description of the item or shown in the drawings, the width of tiles selected for use shall not be less than 595 x 595mm in size and of approved texture, design and patterns and shall be 15mm thick fully perforated square/ butt edged type.



Where width and height of room is in multiple of standard width of tiles/panels, same pattern shall be maintained throughout the length. Where the width and height of rooms is not in multiple of standard width of tiles, cut tile of same design shall be used, material of tile shall be provided in design approved by the Engineer-in-charge and maintained uniformly throughout of the length / height of room.

Calcium silicate tiles shall have the following properties:

- (a) **Surface:** All tiles are prime coated on both sides. Standard finish in two coats white dispersion type, solvent free paint.
- (b) **Dimensions:** 595mmx595mm Butt look Edged. The nominal panel size may differ where cut tile are used to make similar pattern
- (c) **Density of material:** 350 kg per cum in the central 10 mm thick portion and 450 kg cum on the butt edge, (Average 370 kg per cum as per ECBC Code 2007).
- (d) **Relative humidity:** 100% RH resistant.
- (e) **Fire resistance:** Non-combustible as per BS:476 Part-4. Fire performance: as per BS:476 (Part-6) for fire propagation and BS 476 (Part 7) for Surface spread of flame.
- (f) **Thermal conductivity:** 0.048 W/m- K - 0.052 W/m- K as per ECBC Code 2007 and ASTM 518-1991.
- (g) **Recycled Content:** Shall have 46-50% recycled content out of which 18-20% should be FLYASH.
- (h) **Acoustic control:** Sound Attenuation 30-32dB  
Noise reduction coefficient (NRC)  
For 5mm fully perforated 0.45-0.65.  
For 5mm fully perforated with 50mm/48 kg<sup>3</sup> density glass wool 0.65-0.85.
- (i) **Light reflectance:**>85%.
- (j) **Weight:** 5 - 5.5Kg/m<sup>2</sup>
- (k) **Glass Wool: (to be procured separately by installer)** 50mm thick of density 48 Kg/m<sup>3</sup> shall be inserted uniformly before laying the tiles/panels.
- (l) **Framing system:** Framing system shall be made from especially fabricated galvanized mild steel sheet of 0.50mm thick pressed sections.

#### 26.18.1.2 Frame

Framing system shall be made from especially fabricated galvanized mild steel sheet of 0.50mm thick pressed sections having hot dipped galvanizing @120gms/m<sup>2</sup> including all sides. Framing system comprising of vertical studs of size 48 x 34 x 36mm, ceiling channel section of size 50 x 32mm fixed to the floor and soffit at 600mm centres and the channel section of size 50 x 32mm is then to be fixed in horizontal direction at 600mm centre to centre so as to form a grid of 600 x 600mm. .

The surface of the frame shall be checked and corrected to true verticality and slopes if any.

#### 26.18.2 Fixing

Framing system shall be made from especially fabricated galvanized mild steel sheet of 0.50mm thick pressed sections having hot dipped galvanizing @120gms/m<sup>2</sup> including all sides. Framing system comprising of vertical studs of size 48 x 34 x 36mm placed at 600mm centre to centre in a floor and

ceiling channel section of size 50 x 32mm fixed to the floor and soffit at 600mm centres using 12mm dia, 50mm long wedge type expanded zinc alloy dash fastener with 10mm bolt. This channel is then to be fixed in horizontal direction at 600mm centre to centre as to form a grid of 600 x 600mm. Glass wool of 50mm thickness and of density 48 Kg/m<sup>3</sup> is then to be inserted in the slot. Finally, calcium silicate tile/ panels are to be screw fixed with self-tapping pan head nickel coated M S screws of size 13 x 3.2mm on the grid leaving an even groove of 1mm between the panels/ tiles as per required pattern, texture and design/ drawing, preferably start from 2.5/4.0ft/window sill height or as per directions of the Engineer-in-Charge. Joint between the tiles/ panels are then be jointed and finished using recommended jointing calcium silicate based compound and fibre joint tape roll of 50 mm wide and two coats of primer suitable for paneling.

### **26.18.3 Finishing**

Care should be taken while fixing Calcium Silicate Wall Panels / Butt edge tiles on the framing system, so that these are even surface, and no undulations are seen, nor the paint remains visible in the perforations, and no dirt marks are visible, (worker should preferably wear clean soft cotton gloves while placing tile).

### **26.18.4 Measurements**

Length and breadth shall be measured correct to a cm. Areas shall be worked out to nearest 0.01sqm. The superficial area of the finished work paneling shall be measured in square meters. No deduction in measurements shall be made for openings of areas upto 0.36 Sqm. Nothing extra shall be payable either for any extra material or labour involved in forming such openings. For openings exceeding 0.36 sqm in area, deductions in measurements for the full opening in multiple of area of each tile (0.36 Sqm) will be made.

### **26.18.5 Rate**

The rate shall include the cost of all materials and labour involved in all the operations described above.

**26.18.6 MTC:** Manufacturers test certificate/ report of invoice to be submitted for every delivery challan by suppliers.

## **26.19 CALCIUM SILICATE FALSE CEILING (TEGULAR EDGED- FIXED TO EXISTING T-FRAME)**

### **26.19.1 Materials**

#### **26.19.1.1 Tiles**

Eco friendly light weight calcium silicate tiles shall be made from Non-cementitious hydrated wet moulded calcium silicate slurry/mixture, reinforced with fibers and natural fillers. Free from formaldehyde and other harmful materials. Does not contain any toxic ingredients. Shall have appropriate recycled material contents.

The Ceiling Tiles shall be of appropriate class and of finished thickness as specified in the description of the item. Only selected tiles of uniform width shall be used. Unless otherwise specified in the description of the item or shown in the drawings, the width of tiles selected for use shall not be less than 595 x 595 mm in size and shall be 15 mm thick integral densified tegular edged type, light weight wet moulded calcium silicate.



Where width of room/ corridor is in multiple of standard width of tiles, same pattern shall be maintained throughout the length. Where the width of rooms/ corridor is not in multiple of standard width of tiles, borders with appropriate width and material of boards shall be provided in design approved by the Engineer-in-charge and maintained uniformly throughout of the length/ width of room/ corridor. Calcium silicate tiles shall have the following properties:

- (a) **Surface:** All tiles are prime coated on both sides. Standard finish in two coats white dispersion type, solvent free paint.
- (b) **Dimensions:**  
595mmx595mmx15mm thick tegular edged. Size referred to are always module sizes. The nominal panel size may differ depending on the suspension system used.
- (c) **Thickness:** 10 mm thick in the center and 15mm thick all around on edge resting portion with integral densified edge.
- (d) **Density of material:** 350 kg per cum in the central 10 mm thick portion and 450 kg cum on the edges, (Average 370 kg per cum as per ECBC Code 2007).
- (e) **Relative humidity:** 100% RH resistant.
- (f) **Fire resistance:** Non-combustible as per BS:476 Part-4. Fire performance: as per BS:476 (Part-6) for fire propagation and BS 476 (Part 7) for Surface spread of flame.
- (g) **Thermal conductivity:** 0.048 W/m- K - 0.052 W/m- K as per ECBC Code 2007 and ASTM 518-1991.
- (h) **Recycled Content:** Shall have 46-50% recycled content out of which 18-20% should be FLYASH.
- (i) **Acoustic control:** Sound Attenuation 30-32dB  
Noise reduction coefficient (NRC)  
Plain & Designer tile: 0.10-0.15.  
For Pin Hole/Texture pattern tiles: 0.20-0.30.  
Pin hole/Texture fully perforated tile: 0.30-0.40.  
For 5mm fully perforated 0.40-0.50.  
For 5mm fully perforated with 50mm/48gsm glass wool 0.65-0.85.
- (j) **Light reflectance:** >85%.
- (k) **Weight:** 5 - 5.5Kg/m<sup>2</sup>.

#### 26.19.1.2 Frame

Frame is already exists at site. The bottom surface of the frame shall be checked and corrected to true plans and slopes.

#### 26.19.2 Fixing

The tiles shall be placed properly in the grids already exists at site, as per required pattern, texture and design/ drawing and as per directions of the Engineer-in-Charge/manufacturer guide line. If required. level of the false ceiling grid shall be checked after placing of calcium silicate tiles and necessary adjustment shall be made wherever required through level adjuster.

### 26.19.3 Finishing

Care should be taken while placing Light Weight calcium silicate tiles into the grid so that there will be no displacement to grid and stains/ dirty marks put by the workers. (worker should preferably wear clean soft cotton gloves while placing tile).

### 26.19.4 Measurements

Length and breadth shall be measured correct to a cm. Areas shall be worked out to nearest 0.01sqm. The superficial area of the finished work ceiling shall be measured in square meters. No deduction in measurements shall be made for openings of areas upto 0.36 Sqm. Nothing extra shall be payable either for any extra material or labour involved in forming such openings. For openings exceeding 0.36 sqm in area, deductions in measurements for the full opening in multiple of area of each tile (0.36 Sqm) will be made.

### 26.19.5 Rate

The rate shall include the cost of all materials and labour involved in all the operations described above.

**26.19.6 MTC:** Manufacturers test certificate/ report of invoice to be submitted for every delivery challan by suppliers.

## 26.20 GLASS FIBRE REINFORCED GYPSUM (GRG) FALSE CEILING (SEMI PERFORATED MICRO TEGULAR EDGED)

### 26.20.1 Materials

#### 26.20.1.1 Tiles

Glass fibre Reinforced Gypsum (GRG) false ceiling tiles shall be made of Gypsum plaster of 75 microns particle size mixed with short length glass fibre filament of 20 microns  $\pm$  5 microns diameter to give it high strength and shall be free from harmful or any toxic ingredients.

Tiles shall be appropriate class and of finished thickness as specified in the description of the item. Only selected tiles of uniform width shall be used. Unless otherwise specified in the description of the item or shown in the drawings, the width of tiles selected for use shall not be less than 595 x 595mm in size and of approved texture, design and patterns and shall be semi perforated 12mm thick micro tegular-edged type GRG tiles.

Where width of room/ corridor is in multiple of standard width of tiles, same pattern shall be maintained throughout the length. Where the width of rooms/ corridor is not in multiple of standard width of tiles, borders with appropriate width and material of boards shall be provided in design approved by the Engineer-in-charge and maintained uniformly throughout of the length/ width of room/ corridor. GRG tiles shall have the following properties:

- (a) **Surface:** The GRG false ceiling tiles shall be painted with white dispersion type solvent free paint.
- (b) **Dimensions:** 595mm x 595mm Semi perforated 12mm thick micro tegular-edged type GRG tiles. Size referred to are always module sizes. The nominal panel size may differ depending on the suspension system used.
- (c) **Density of material:** 700 to 850 kg per Cum.
- (d) **Relative humidity:** 99% RH resistant.
- (e) **Fire resistance:** Non-combustible as per BS:476, Part-4: 1970

- (f) **Moisture Content:** < 2%
- (g) **Acoustic control:** Noise reduction coefficient (NRC) = 0.50 to 0.75 as per IS: 8225-1981.
- (h) **Light reflectance:**>85%
- (i) **Suspension system:** Suspension system shall be made of interlocking metal T-grids of hot-dipped galvanized iron section.

#### **26.20.1.2 Frame**

Frame is made up of interlocking metal T-grids of hot dipped galvanized steel sections of 0.33mm thick (Galvanized @ 120 grams per sqm including both sides) comprising of main T runners of size 15 x 32mm of length 3000mm, cross T of size 15 x 32mm of length 1200mm and secondary intermediate cross T of size 15 x 32mm of length 600mm to form grid modules of size 600 x 600mm. This grid shall be suspended from ceiling using galvanized mild steel members (Galvanized @ 80 gms/m<sup>2</sup> including all sides) i.e. 50mm long, 8mm outer diameter M-6 dash fasteners, 6mm dia fully threaded hanger rod upto 1000 mm length and L-shaped level adjuster of size 85 x 25 x 2mm. Frame also consist of galvanized iron perimeter wall angle of size 24 x 24 x 0.40mm of length 3000mm to be fixed on periphery wall/ partition with the help of plastic rawl plugs at 450mm centre to centre and 40mm long dry wall SS screws.

The bottom surface of the frame shall be checked and corrected to true plans and slopes.

#### **26.20.2 Fixing**

Outer wall angle shall be fixed accurately and truly at required height and level, parallel and close to the wall. Thereafter all the T members shall be placed and fixed carefully to form the grid. The grid comprises of main T-runners at 1200mm centres securely fixed to the structural soffit by approved and adjustable hanger rods at 1200mm maximum centres and not more than 150mm from spliced joints of main T-runners. The last hanger at the end of each runner should not be greater than 600mm from the adjacent wall. Similarly, cross T-runners of 1200mm length shall be placed at 600mm centre to centre. 600x600mm modules to be formed by fitting 600mm long flush fitting cross Tees (secondary cross T) centrally between 1200mm cross T-runners. The tiles shall then be placed properly in the grids as per required pattern, texture and design/ drawing and as per directions of the Engineer-in-Charge. If required, level of the false ceiling grid shall be checked after placing of semi perforated GRG tiles and necessary adjustment shall be made wherever required through level adjuster.

#### **26.20.3 Finishing**

Care should be taken while placing semi perforated GRG tiles into the grid so that there will be no displacement to grid and stains/ dirty marks put by the workers.

#### **26.20.4 Measurements**

Length and breadth shall be measured correct to a cm. Areas shall be worked out to nearest 0.01sqm. The superficial area of the finished work ceiling shall be measured in square metres. No deduction in measurements shall be made for openings of areas upto 0.36 Sqm. Nothing extra shall be payable either for any extra material or labour involved in forming such openings. For openings exceeding 0.36 sqm in area, deductions in measurements for the full opening in multiple of area of each tile (0.36 Sqm) will be made.

#### **26.20.5 Rate**

The rate shall include the cost of all materials and labour involved in all the operations described above.

## **26.21 GLASS FIBRE REINFORCED GYPSUM (GRG) FALSE CEILING (FULLY PERFORATED MICRO TEGULAR EDGED)**

### **26.21.1 Materials**

#### **26.21.1.1 Tiles**

Glass fibre Reinforced Gypsum (GRG) false ceiling tiles shall be made of Gypsum plaster of 75 microns particle size mixed with short length glass fibre filament of 20 microns  $\pm$  5 microns diameter to give it high strength and shall be free from harmful or any toxic ingredients.

Tiles shall be appropriate class and of finished thickness as specified in the description of the item. Only selected tiles of uniform width shall be used. Unless otherwise specified in the description of the item or shown in the drawings, the width of tiles selected for use shall not be less than 595 x 595mm in size and of approved texture, design and patterns and patterns and shall be fully perforated 12mm thick micro tegular-edged type GRG tiles.

Where width of room/ corridor is in multiple of standard width of tiles, same pattern shall be maintained throughout the length. Where the width of rooms/ corridor is not in multiple of standard width of tiles, borders with appropriate width and material of boards shall be provided in design approved by the Engineer-in-charge and maintained uniformly throughout of the length/ width of room/ corridor. GRG tiles shall have the following properties:

- (a) **Surface:** The GRG false ceiling tiles shall be painted with white dispersion type solvent free paint. fully perforated GRG false ceiling tiles shall have a non-woven fabric of density minimum 30 grams per square meter pasted at the back.
- (b) **Dimensions:** 595mm x 595mm Fully perforated 12mm thick micro tegular-edged type GRG tiles. Size referred to are always module sizes. The nominal panel size may differ depending on the suspension system used.
- (c) **Density of material:** 700 to 850 kg per Cum.
- (d) **Relative humidity:** 99% RH resistant.
- (e) **Fire resistance:** Non-combustible as per BS: 476, Part-4: 1970
- (f) **Moisture Content:** < 2%
- (g) **Acoustic control:** Noise reduction coefficient (NRC) = 0.50 to 0.75 as per IS: 8225-1981.
- (h) **Light reflectance:** >85%
- (i) **Suspension system:** Suspension system shall be made of interlocking metal T-grids of hot-dipped galvanized iron section.

#### **26.21.1.2 Frame**

Frame is made up of interlocking metal T-grids of hot dipped galvanized steel sections of 0.33mm thick (Galvanized @ 120 grams per sqm including both sides) comprising of main T runners of size 15 x 32mm of length 3000mm, cross T of size 15 x 32mm of length 1200mm and secondary intermediate cross T of size 15 x 32mm of length 600mm to form grid modules of size 600 x 600mm. This grid shall be suspended from ceiling using galvanized mild steel members (Galvanized @ 80 gms/m<sup>2</sup> including all sides) i.e. 50mm long, 8mm outer diameter M-6 dash fasteners, 6mm dia fully threaded hanger rod upto 1000 mm length and L-shaped level adjuster of size 85 x 25 x 2mm. Frame also consist of galvanized iron perimeter wall angle of size 24 x 24 x 0.40mm of length 3000mm to be fixed on periphery wall/ partition with the help of plastic rawl plugs at 450mm centre to centre and 40mm long dry wall SS screws.

The bottom surface of the frame shall be checked and corrected to true plans and slopes.

### **26.21.2 Fixing**

Outer wall angle shall be fixed accurately and truly at required height and level, parallel and close to the wall. Thereafter all the T members shall be placed and fixed carefully to form the grid. The grid comprises of main T-runners at 1200mm centres securely fixed to the structural soffit by approved and adjustable hanger rods at 1200mm maximum centres and not more than 150mm from spliced joints of main T-runners. The last hanger at the end of each runner should not be greater than 600mm from the adjacent wall. Similarly, cross T-runners of 1200mm length shall be placed at 600mm centre to centre. 600x600mm modules to be formed by fitting 600mm long flush fitting cross Tees (secondary cross T) centrally between 1200mm cross T-runners. The tiles shall then be placed properly in the grids as per required pattern, texture and design/ drawing and as per directions of the Engineer-in-Charge. If required, level of the false ceiling grid shall be checked after placing of semi perforated GRG tiles and necessary adjustment shall be made wherever required through level adjuster.

### **26.21.3 Finishing**

Care should be taken while placing semi perforated GRG tiles into the grid so that there will be no displacement to grid and stains/ dirty marks put by the workers.

### **26.21.4 Measurements**

Length and breadth shall be measured correct to a cm. Areas shall be worked out to nearest 0.01sqm. The superficial area of the finished work ceiling shall be measured in square metres. No deduction in measurements shall be made for openings of areas upto 0.36 Sqm. Nothing extra shall be payable either for any extra material or labour involved in forming such openings. For openings exceeding 0.36 sqm in area, deductions in measurements for the full opening in multiple of area of each tile (0.36 Sqm) will be made.

### **26.21.5 Rate**

The rate shall include the cost of all materials and labour involved in all the operations described above.

## **26.22 MINERAL FIBRE FALSE CEILING (BEVELED TEGULAR MINERAL FIBRES)**

### **26.22.1 Materials**

#### **26.22.1.1 Tiles**

Mineral Fiber Ceiling Tiles shall be made of granulated high-density Mineral Wool as the main material and top production technique which gives it superior features of fire-proofing, sound absorption, heat insulation & sag resistance. They are cost effective and are mainly used for acoustics and decoration.

Tiles shall be appropriate class and of finished thickness as specified in the description of the item. Only selected tiles of uniform width shall be used. Unless otherwise specified in the description of the item or shown in the drawings, the width of tiles selected for use shall not be less than 595 x 595mm in size and of approved texture, design and patterns and shall be of 16mm/ 20mm thick Beveled Tegular edge type.

Where width of room/ corridor is in multiple of standard width of tiles, same pattern shall be maintained throughout the length. Where the width of rooms/ corridor is not in multiple of standard width of tiles, borders with appropriate width and material of boards shall be provided in design approved by the Engineer-in-charge and maintained uniformly throughout of the length/ width of room/ corridor. Mineral Fibre tiles shall have the following properties:

- (a) **Surface:** Shall be of approved texture, design and pattern.

- (b) **Dimensions:** 595mm x 595mm x 16mm (20mm) thick Beveled Tegular edge type. Size referred to are always module sizes. The nominal panel size may differ depending on the suspension system used.
- (c) **Relative humidity:**99% RH resistant.
- (d) **Fire resistance:** Fire performance as per BS:476 (Part-6 & 7)
- (e) **Thermal conductivity:** 0.052 W/m–K – 0.057 W/m–K
- (f) **Acoustic control:** Noise reduction coefficient (NRC) = 0.50 to 0.60
- (g) **Light reflectance:**>85%.
- (h) **Weight:** 3.10 Kg/m<sup>2</sup> (for 16mm thick) & 5.29 Kg/m<sup>2</sup> (for 20mm thick)
- (i) **Suspension system:** Suspension system shall be made of interlocking metal T-grids of hot-dipped all round galvanized steel.

#### 26.22.1.2 Frame

Frame is made up of interlocking metal T-grids of hot dipped all round galvanized steel sections of 0.33mm thick (Galvanized @ 120 grams per sqm including both sides) comprising of main T runners of size 15 x 32mm of length 3000mm, cross T of size 15 x 32mm of length 1200mm and secondary intermediate cross T of size 15 x 32mm of length 600mm to form grid modules of size 600 x 600mm. This grid shall be suspended from ceiling using galvanized mild steel members (Galvanized @ 80 gms/m<sup>2</sup> including all sides) i.e. 50mm long, 8mm outer diameter M-6 dash fasteners, 6mm dia fully threaded hanger rod upto 1000 mm length and L-shaped level adjuster of size 85 x 25 x 2mm. Frame also consist of galvanized iron perimeter wall angle of size 24 x 24 x 0.40mm of length 3000mm to be fixed on periphery wall/ partition with the help of plastic rawl plugs at 450mm centre to centre and 40mm long dry wall SS screws.

The bottom surface of the frame shall be checked and corrected to true plans and slopes.

#### 26.22.2 Fixing

Outer wall angle shall be fixed accurately and truly at required height and level, parallel and close to the wall. Thereafter all the T members shall be placed and fixed carefully to form the grid. The grid comprises of main T-runners at 1200mm centres securely fixed to the structural soffit by approved and adjustable hanger rods at 1200mm maximum centres and not more than 150mm from spliced joints of main T-runners. The last hanger at the end of each runner should not be greater than 600mm from the adjacent wall. Similarly, cross T-runners of 1200mm length shall be placed at 600mm centre to centre. 600x600mm modules to be formed by fitting 600mm long flush fitting cross Tees (secondary cross T) centrally between 1200mm cross T-runners. The tiles shall then be placed properly in the grids as per required pattern, texture and design/ drawing and as per directions of the Engineer-in-Charge. If required, level of the false ceiling grid shall be checked after placing of calcium silicate tiles and necessary adjustment shall be made wherever required through level adjuster.

#### 26.22.3 Finishing

Care should be taken while placing calcium silicate tiles into the grid so that there will be no displacement to grid and stains/ dirty marks put by the workers.

#### 26.22.4 Measurements

Length and breadth shall be measured correct to a cm. Areas shall be worked out to nearest 0.01sqm. The superficial area of the finished work ceiling shall be measured in square metres. No deduction in measurements shall be made for openings of areas upto 0.36 Sqm. Nothing extra shall



be payable either for any extra material or labour involved in forming such openings. For openings exceeding 0.36 sqm in area, deductions in measurements for the full opening in multiple of area of each tile (0.36 Sqm) will be made.

#### **26.22.5 Rate**

The rate shall include the cost of all materials and labour involved in all the operations described above.

#### **26.23 MINERAL FIBRE FALSE CEILING (BEVELED TEGULAR MINERAL FIBRE ANTI-MICROBIAL)**

Specification for the mineral fibre false ceiling using 16 mm Beveled Tegular Mineral Fibre Anti-microbial is same as 16 mm Beveled Tegular Mineral Fibres specified in above clause 26.22.

#### **26.24 CHIPPING OF UNSOUND / WEAK CONCRETE:**

##### **26.24.1 Precaution, Preparation and procedure**

The Chipping of unsound work / concrete / delaminated layer of gunniting etc. shall be done by chipping( after properly supporting the member with false works) , in regular shape, with sides parallel or normal to the direction of the reinforcement. The chipping shall be done minimum 50 mm beyond the perimeter of the spell. For a single spell, the repair area should have a minimum width of 100 mm in any direction. If a number of spells are closely located to each other, these should be included in a single area marked for repair. The cut shall be made normal to the surface of member. The minimum depth of cut should be 12 mm.

Adequate care is to be taken not to cut the reinforcement steel and a cover metre could be used to estimate the depth of cover, for which nothing extra shall be paid.

Chipping should be done upto the required depth as decided by the Engineer-in- Charge to produce sound concrete surface to a near uniform depth for the repair areas.

Removal of concrete should begin at the interior of the repair areas and progress towards the boundaries. All edges and cavities shall be square shouldered.

##### **26.24.2 Measurements**

Dimensions of area chipped off for RCC slabs, beams, columns etc. shall be measured in centimeters after the chipping / dismantling operation is completed for different thicknesses as specified in the item separately. The area of the chipped / exposed RCC surface shall be measured in sq. m correct to second place of decimal for different thicknesses as specified in the item separately.

**26.24.3 Rate:-** The rate shall include the cost of all the T&P required, labour involved and cost of all the operations as described above.

#### **26.25 CLEANING OF EXISTING REINFORCEMENT AND PASSIVATING ITS SURFACE**

##### **26.25.1 Material:-**

The alkaline chemical rust remover as approved by the Engineer-in Charge and should be procured in sealed containers indicating the batch number and the date of manufacture etc.

##### **26.25.2 Surface preparation-**

The rust has to be removed from the surface of the reinforcement manually using chisels, wire brush, emery paper etc. as directed by Engineer-in-Charge at no extra cost, till the steel surface is cleared of all rust that could be removed manually or mechanically.

**26.25.3 Application:-**

Then alkaline chemical rust remover, as approved by the Engineer-in Charge shall be applied with brush over the reinforcement surface thoroughly along the full length of rusted reinforcement. After 24 hours of its application the surface shall be cleaned with wire brush and all loose particles removed. It should then be washed clean, with water, thoroughly and allowed to dry. alkaline chemical rust remover should be applied to the reinforcement approximately one litter for 6 to 7 sqm. Of the steel area (assuming the surface of the reinforcement of rough) the consumption of the alkaline chemical rust remover should be about 0.40 liters per 10 Sqm. Area of RCC unit.

**26.25.4 Measurements:** - The length of the reinforcement bar cleaned shall be measured correct to a centimeter in two categories i.e. i) Bars upto 12mm dia. ii) Bars above 12mm dia.

**26.25.5 Rates :-** shall include cost of all materials, labour, T&P etc. involved in all the operations as described above.

**26.26 DRILLING SUITABLE HOLES IN RCC OR PLAIN CEMENT CONCRETE****26.26.1 Preparation and Procedure**

For introducing additional reinforcement bars for new structural connections or supplementing additional steel area to the existing RCC member, the cross sectional area ( diameter and no. of bars) and length required shall be approved by the Engineer-in-Charge. Also the depth of embedment of reinforcement bar shall be approved by the Engineer-in-Charge. The holes have to be power drilled in RCC. The drilled hole in dry state has to be cleaned with round brush and by blowing air through a tube inserted in the hole and connected to hand operated blower.

Then epoxy is to be injected from foil pack with help of epoxy dispenser and epoxy cartridge holder and disposable PVC mixing nozzle inserted inside the drilled hole to fill it from bottom of hole and upwards. Then the reinforcement bar is to be inserted and allowed to remain undisturbed for minimum 24 hours and allow epoxy adhesive to be air cured. Epoxy resin anchor grout shall be approved by the Engineer-in Charge.

**26.26.2 Measurements:-** Holes shall be enumerated.

**26.26.3 Rates :-** Shall include cost of all inputs of material, labour and T&P etc. involved in all the operations except the cost of reinforcement.

**26.27 BONDING COAT**

**26.27.1 Material:-** SBR polymer modified cementitious bond coat and epoxy bonding adhesive shall be approved by the Engineer-in Charge.

**26.27.2 Surface Preparation:-**

Bonding coat is required to be applied for adhesion of applied repair concrete or mortar to the parent concrete. For this, the surface should be thoroughly cleaned by brushes and by blowing air from hand operated pump. The surface shall then be saturated with water (but without excess water).

**26.27.3 Application:-**

The components of bonding coat shall be weigh batched and mixed in specific proportions, in a clean container, as directed by the Engineer-in-Charge. They should then be blended to a uniform and homogeneous mixture, lump free and of creamy consistency.



The specified bond coat should be applied by stiff nylon bristle brush. The bonding material should be worked well onto the concrete surface of the parent concrete including reinforcement surface ensuring that no pinholes are visible. The SBR polymer modified bonding cement slurry shall be applied to a thickness not more than 2 mm. A second coat shall be applied within 15 to 20 minutes of application of the first coat at right angles to the first coat to ensure complete coverage and absence of pin holes.

#### **26.27.4 Measurements**

Area of exposed RCC unit shall be measured in sqm correct to two decimal places for the purpose of payment.

#### **26.27.5 Rates :-**

Shall include cost of all inputs of material, labour and T&P etc. involved in all the operations as described above.

### **26.28 PROVIDING, MIXING AND APPLYING SBR POLYMER MODIFIED CEMENT MORTAR**

#### **26.28.1 Procedure and application**

Fresh mortar shall be applied while the bond coat is still tacky and well within setting period. If adhesive cured to the extent of losing its tack or has set before mortar is applied. The same shall be removed or slightly abraded and another coat of bond coat shall to be applied by the contractor at his own cost. Freshly placed mortar shall be thoroughly consolidated to ensure full bonding of the fresh mortar with the parent concrete. If there is a failure of bond of fresh mortar/ plaster with parent concrete surface and it sounds hollow on tapping, the repair work shall be dismantled and redone by the contractor at his own cost and to the entire satisfaction of the Engineer-in-Charge.

**26.28.2 Testing :** 75mm size cube of the mortar, crushing strength at the end of 28 days to be not less than 30 N/Sqmm<sup>2</sup>.

#### **26.28.3 Measurement**

Length and breadth of the application shall be measured correct to a cm and area worked out to in sqm upto 2 decimal places, separately for different thicknesses specified in the item.

#### **26.28.4 Rates**

Rates shall include all the materials, labour, T&P in all the operations as described above.

### **26.29 APPLYING SBR POLYMER MODIFIED CEMENT CONCRETE FOR STRUCTURAL MEMBERS**

**26.29.1 Material:** SBR polymer or equivalent material shall be approved by Engineer-in-charge.

#### **26.29.2 Preparation & application**

After bonding coat pre fabricated shuttering shall then be erected immediately. Fresh concrete shall be placed /applied while the bond coat is still tacky and well within pot - life / setting period. If adhesive cures to the extent of losing its tack or has set before concrete is placed / applied, the same shall be removed or slightly abraded and another coat of adhesive / bond coat shall have to be applied by the contractor at his own cost. Freshly placed concrete shall be thoroughly consolidated to ensure full bonding of the fresh concrete with the parent concrete. If there is a failure of bond of fresh concrete with parent concrete surface and it sounds hollow on tapping, the repair work shall be dismantled and redone by the contractor at his own cost and to the entire satisfaction of the Engineer-in-Charge.

Thickness and grade of concrete: As specified in the item with graded stone aggregate of 10 mm maximum size in proportion as per design criteria.

**26.29.3 Testing:** As per design mix criteria.

**26.29.4 Measurement:** Length and breadth of the application shall be measured correct to a cm and area worked out to in sqm upto 2 decimal places, separately for different thicknesses specified in the item.

**26.29.5 Rates**

Rates shall include all the materials, labour, T&P and full curing period in all the operations as described above.

**26.30 PROVIDING AND INJECTING GROUT**

**26.30.1 MATERIAL :** The materials for injection grouting shall be approved by the Engineer-in-charge.

**26.30.2 Surface preparation**

The final chipped off concrete surface and exposed reinforcement, if any, of the affected structural member should be cleaned off all loose and foreign materials by free air blast and then with water and allow it to dry. For the honey combed portion of the concrete or cracked concrete, drill holes at least 18 mm in diameter and depth upto 50 mm or half the member thickness whichever is less, at the required spacing, as directed by the Engineer-in-Charge. For cracked surface, open up cracks by making V notch or groove of size 12 mm X 12 mm as directed by the Engineer-in-Charge. Remove coarse debris and dust in opened up cracks and drilled holes by blowing air with hand operated blow out pump. Concrete surface required to be grouted shall be free from all loose and unsound material. The prepared surface should be clear of dust which could obstruct free flow of grout material and also impede its bonding with concrete surface. Saturate the concrete in vicinity of crack / honey combed concrete surface with water (but without excess water) only if the cement / polymer admixed grout is to be injected.

**26.30.3 Application:** The emulsified acrylic polymer/SBR polymer shall be as specified and shall conform to Manufacturer's specification. The physical and mechanical properties of polymers shall conform to manufacturer's specification. One test shall be carried out mandatory for every lot of acrylic polymer/SBR polymer supplied at site, before use in the work. The grouting equipment shall be capable of supplying mixing, stirring and pumping grout to the satisfaction of Engineer-in-charge. It shall have capacity to inject grout at a pressure upto 7 kg / sq. cm measured at grout connections. It shall be capable of mixing and pumping the cement sand grout 1:2(1 cement : 2 sand) with water cement ratio ranging from 0.5 to 1.0. Wherever epoxy is to be used, the surface of the concrete shall be dried with air blast, before grouting or applying epoxy. The cement grout in proportion as directed by the Engineer-in-Charge shall be prepared. It should be lump free of creamy consistency, thoroughly blended and shall be continuously stirred to keep the cement particles in suspension to retain uniform consistency till grout is injected. In case of vertical cracks the injection shall be started at the lowest nipple and continued until the injected grout begins to flow out at the next higher nipple. The first nipple shall then be closed and injection continued from second until grout flows out at the third and so on. The process shall be repeated until the whole surface is treated. As soon as the system is cured, the nipples shall be suitably cut. In case of honey combed concrete, each grout hole shall be grouted individually. The sequence of injection shall be as per the directions of the Engineer-in-Charge.

**26.30.4 Measurement :** The measurement of grout material shall be on the basis of actual weight of approved grout injected. Pre measurements of the quantities of such grouting materials brought at site and balance quantities remaining at the end of grouting application shall be recorded separately, which will determine the quantity of grout material actually injected. Adequate care is to be taken by the contractor as not to waste the grout. The quantity which can be consumed immediately within the prescribed time only shall be prepared in batches. The quantity of grout material wasted, discarded, hardened shall not qualify for payment and shall be recorded for deduction at the end of each operation.

**26.30.5 Rates:** The rate shall include all the operation, labour, materials described above except injection nipple which will be paid in the relevant item.

### **26.31 PROTECTIVE FABRIC SCREENS**

**26.31.1 Material :** The PVC woven cloth shall be approved by Engineer-in-charge.

#### **26.31.2 Procurement & Execution :**

Before execution, profile of protective fabric screen shall be got approved by the Engineer-in-charge. Protective Fabric screening shall be provided by the contractor with PVC woven cloth covering full height of the structure. It shall be provided by properly stitching the screen, having adequate lapping on sides to prevent any rubbish from falling outside while demolishing, dismantling, gunniting, plastering etc. and to protect passers -by from the falling debris. Screen material shall be fixed by suitable means to the frames of scaffolding etc, and it is to be ensured that sagging of screen does not hinder the repair process. The contractor shall maintain the protective screen in acceptable working conditions for the entire duration of the repair work as required by the Engineer-in-Charge. All the windows, ventilators, RCC jalis and openings shall be suitably covered and protected, in advance so as not to cause any damage while doing the repair work. If any damage is caused or glass panes are broken, these shall be made good by the contractor at his own cost and to the entire satisfaction of Engineer-in-Charge.

**26.31.3 Measurement:** Length and height of the Protective fabric screen along the approved profile shall be measured correctly and area worked out to in sqm upto 2 decimal places,

**26.31.4 Rates;** Rates shall include all the materials, labour, T&P in all the operations as described above i/c cost of double scaffolding for fixing the protective screen.

### **26.32 CLEANING OF EXPOSED CONCRETE SURFACE BY SAND BLASTING**

**26.32.1 Equipment:** Sand blasting equipment and air compressor shall be got approved by Engineer-in-Charge and should be capable of doing at least 14 sqm of cleaning the surface a day. The coarse sand used in blasting shall be of zone III.

**26.32.2 Operation:** The cleaning should start after program for Shotcreting/Guniting, etc. is fixed, such that cleaned, surface shall not be left alone for long. Cleaned surface should also be got approved by Engineer –in-Charge. Proper care to the workers and environment should be taken and other parts of the bldg should be protected to avoid any mishap.

**26.32.3 Procedure** – As described in the item.

**26.32.4 Measurement**- Length & breadth shall be measured correct to a cm and area worked out to be sqm. upto 2 places of decimals.

**26.32.5 Rates**- Rate shall include all the operations as described above and in the item.

### **26.33 SHOTCRETING**

#### **26.33.1 Materials**

Design mix of specified grade shall be got approved by Engineer-in-Charge before start of work. The maximum size of graded stone aggregate shall not exceed 10mm. The minimum cement content shall be as specified in the item.

**26.33.2 Surface preparation**- The surface shall be thoroughly cleaned and the cleaned surface should be got approved by Engineer-in-Charge

**26.33.3 Equipment**- The compressor, gun, rubber pipes & other accessories shall be approved by Engineer-in-Charge. The equipment should be capable of doing at least 40m<sup>2</sup> of shotcreting a day for 25mm thickness

**26.33.4 Application** – Application should start from top to bottom vertically and then from left to right or right to left as per feasibility horizontally. The thickness shall be as specified in the item. Then the surface shall be kept wet for at least 14 days or as per direction of Engineer-in-Charge. Thereafter the surface shall be evaluated by sounding/tapping with a blunt metal instrument. If any hollow or defective portion is observed, the same shall be redone after dismantling the same.

**26.33.5 Testing**: C.C cube strength should confirm the specified grade of concrete.

**26.33.6 Measurement**- The length and breadth shall be measured correct to a cm for different thicknesses separately and area shall be worked out in m<sup>2</sup> upto 2 decimal places.

**26.33.7 Rates**- Rate shall include all materials, labour, operations described above. The rate shall also include for providing necessary ground wires etc. The leveling gauges if used shall be paid separately. Payment under this item shall be made only after proper wet curing has been done and surface has been satisfactorily evaluated.

### **26.34 PROVIDING AND INSERTING GALVANIZED STEEL INJECTION NIPPLE**

#### **26.34.1 Materials**

Galvanized Steel injection nipple 12mm dia 75mm long shall be got approved by Engineer-in-Charge. The chemical adhesive shall be got approved by the Engineer-in-Charge.

**26.34.2 Surface preparation and operation**: Holes shall be drilled in honey comb area and along crack line of required dia (20mm to 30 mm) upto depth from 30mm to 80mm at required spacing. Spacing and pattern of the holes shall be got approved by Engineer-in-Charge. The holes and cracks shall be made dust free by blowing compressed air. After inserting the injection nipple, the holes shall be sealed with chemical adhesive. The chemical adhesive shall be allowed to cure completely.

**26.34.3 Measurement** – Injection nipples shall be enumerated.

**26.34.4 Rates**- The rate shall include all the materials, labour, operations as described above.

### **26.35 PROVIDING & FIXING HARD DRAWN STEEL WIRE FABRIC**

**26.35.1 Materials**- Hard drawn steel wire fabric of size 75 x 25 mm weighing not less than 7.75 kg/m<sup>2</sup> or any other suitable size wire mesh shall be got approved by Engineer-in-Charge before use on work. 10 mm dia mild steel bar for shear key shall be approved by Engineer-in-Charge before use on work.

**26.35.2 Preparation and procedure**- The surface should be cleaned thoroughly before fixing of the mesh. 100mm long pieces of mild steel 10mm dia bar shall be cut. Each piece shall be bent into L shape. One arm of the L shape piece shall be welded to existing reinforcement with the spacing 50cm center to center or less in both directions as approved by Engineer-in-Charge. Then hard drawn steel wire fabric shall be inserted into the shear keys and fastened with the help of binding wire or welded to shear keys as approved by Engineer-in-Charge

**26.35.3 Measurement** – Length & breadth/height shall be measured correct to a cm and area shall be worked out in sqm upto 2 decimal places.

**26.35.4 Rates**- Rates shall include all the materials labour and operations as described above.

### **26.36 LIGHT GAUGE STEEL FRAMED STRUCTURE (LGSFS)**

#### **26.36.1 General**

Light Gauge Steel Framed Structure (LGSFS) is based on factory made galvanized light gauge steel components produced by the cold forming method assembled as panels at site forming structural steel framework of a building and varying wall and floor construction. The panels are assembled on site with screws and bolts to form the internal and separating walls and inner leaf of the external walls of a building and floors & ceiling.

The system can incorporate all types of architectural features like coving, boxes, cantilevers, projections, infill walls, mezzanine floors etc. This system can also incorporate all types of services viz. electrical, gas and plumbing etc. The design and engineering of the structures is executed by following the norms & guidelines stipulated in relevant Indian Standards.

The system shall be used as framed steel structure.

#### **26.36.2 Limitation of Use**

- (i) LGSFS may be used only upto G+3 level without any composition.
- (ii) LGSFS may be used in G+3 and above with composition of hot rolled structures.
- (iii) LGSFS shall not be used for buildings with vibrations.
- (iv) Advisable span for LGSFS buildings shall be up to 6.5m.

#### **26.36.3 Profiles and Sizes of Framing Components**

The wall and floor panels are assembled from C section having minimum web depth 89 mm x 39 mm flange x 11 mm lip in required length as per structural design. The minimum thickness of section shall be 0.75 mm and it shall be governed by the structural design requirement. The slots will be along centre line of webs and shall be spaced minimum 250mm away from both ends of the member.

The steel sheet shall be galvanized (AZ-150gms Aluminium Zinc Alloy coated steel having minimum yield strength 300-550 Mpa) conforming to AISI specifications and IBC 2009 for cold formed steel framing and construction and also as per IS: 875-1987, ISO 800-1984 and IS:801- 1975.

#### **26.36.4 Design and Stability Report**

LGSFS frame shall be designed as per IS: 801 using commercially available software such as Frame CAD Pro-11.7/ STAAD PRO-V8i/ArchitekV2.5.16/ Rivet architecture-2011 or equivalent. The wind load shall be as per provisions of IS 875 (part -III).

The item also includes the submission of stability reports duly examined and issued by any NIT/IIT.

#### **26.36.5 Connections**

The frame can be supplied in panellized or knock down condition in specific dimensions and fastened with screws extending through the steel beyond by minimum of three exposed threads. All self drilling tapping screws for joining the members shall have a Type II coating in accordance with ASTM B633(13) or equivalent corrosion protection of gauge 10 & 12, TPI 16 & 8 of length 20mm. The frames shall be fixed to RCC slab or Tie beam over Neoprene rubber using self expanding carbon steel anchor bolt of dia as per approved drawings. design subject to minimum 12mm diameter and 121mm length conforming to AISI 304 and 316 at 500mm c/c with minimum embedment of 100mm in RCC (RCC to be paid separately) and located not more than 300mm from corners or termination of bottom tracks complete in all respects.

#### **26.36.6 Measurement:**

Only weight of Cold form light gauge Steel C-section of thickness 0.75mm i/c zinc coating/sliting etc. shall be considered in Kg, excluding connection accessories such as screws, nuts, bolts etc.

#### **26.36.7 Rate**

The rate includes the concept design, detailed design, fabrication of sections, transportation, installation and all required fixing arrangement at site as described above.RCC to be paid separately.

### **26.37 EXTERNAL WALL SYSTEM ON LIGHT GAUGE STEEL FRAME WORK WITH OUTER FACE HAVING 6MM THICK FIBER CEMENT BOARD**

#### **26.37.1 For Cement Fibre Board**

##### **26.37.1.1 Nominal Length and Width**

Flat fibre cement sheets shall be available in nominal lengths up to 3 000 mm and nominal widths up to 1240 mm.

**26.37.1.2 Min. Modulus of Rupture:** For 6mm & 9mm :13MPA

**26.37.1.3 Thickness:** Flat fibre cement sheets shall be 6, 8, 9mm.

**26.37.1.4 Tolerances on Dimensions:** Tolerances on nominal dimensions shall be as follows:

(a) On length and width (indicated by d)

$d \leq 1000 \text{ mm} : \quad \pm 5\text{mm}$

$1000 \text{ mm} < d \leq 1600 \text{ mm} : \quad \pm 0.5 \text{ percent}$

$d > 1600 \text{ mm} : \quad \pm 8\text{mm}$

These tolerances do not apply to oversize sheets.

(b) On thickness, e :

$e \leq 6\text{mm} : \pm 0.6\text{mm}$

$e > 6\text{mm} : \pm 10\text{percent}$

For sheets without texture on the exposed face, the maximum difference between extreme values of the thickness measurements within one sheet shall not exceed 15 percent of the maximum measured value



#### **26.37.1.5 Tolerances on Shape**

Straightness of edges: The tolerance on the straightness of edges shall be 3 mm/m for the relevant dimension (length or width) when measured in accordance with the method given

Squareness of edges: The tolerance on the squareness of sheets shall be 4 mm/m when measured in accordance with the method given.

#### **26.37.1.6 Acceptance Tests**

The objective of an acceptance test is to establish whether a batch of products conforms to a specification. The tests shall be performed on samples drawn either from continuous production or from a consignment (see also 8). The acceptance test shall be carried out at the manufacturer's works on sheets and test specimens cut from sheets as delivered. The following acceptance tests shall be carried out:

- (a) Dimensional and geometrical characteristics (compulsory) ,
- (b) Bending strength (compulsory) , and
- (c) Apparent density (compulsory).

**26.37.1.7 Method for testing:** As per IS 14862 2000

### **26.37.2 For Gypsum Plaster Board**

#### **26.37.2.1 Material**

Gypsum Plaster Board shall conform to IS 2095.

Gypsum plaster shall conform to IS 2547 (Part 1). Byproduct gypsum conforming to the requirements of IS 12679 shall also be used for the preparation of plaster.

Requirements, tests, sampling, finishing etc of Gypsum Plaster Board shall be as per IS 2095.

#### **26.37.2.2 Fixing**

Fixing the outer face with moisture resistant/ fire resistant fibre cement board of 6mm and 9mm thickness (High Pressure Steam cured) with necessary accessories & GI self drilling/ tapping screws etc., of required size (Screws shall be of counter sunk rib head of 1.60mm to 4 mm thick of 8 to 10 gauge of length varying from 25 to 45 mm) @ 60cm c/c, and a groove of 2-3mm shall be maintained and filled with suitable arrangement as per approval of Engineer-in-charge.

Filling the groove (i.e. 2-3mm gap between boards),taping and jointing of the first layer 6mm and 9mm thick fiber cement boards with epoxy based sealing compound or with silicon sealant. Second layer is fixed over it in a staggered pattern.

Fixing the internal face with 12.5mm thick gypsum plaster board fixed on 8mm thick fiber cement board with self-drilling / tapping screws / fasteners @ 60cm c/c of approved make, proper taping and jointing to be done using fiber mesh tape and epoxy and acrylic based jointing compound for seamless finish.

Fill the groove (i.e. 2-3mm gap between boards),taping and jointing 8mm thick fiber cement board and 12.5mm thick gypsum plaster boards with epoxy based sealing compound, Acrylic based sealing compound, Non woven reinforcement Tape as per direction of Engineer in charge.(Use a flexible knife so that no air bubble is entrapped. Allow 1-2 hours gap. Once hard tacky or set, apply a coat of Acrylic based sealing compound paste to flash fill the beveled area. After 2-4 hours go on to repeat a skin coat with Acrylic based sealing compound to securely embed the 40mm width (non

woven reinforcement Tape. Use only flexible steel knife, such as provided with packs, to avoid air entrapment within compound. After overnight drying shrinkage apply a coat of acrylic based sealing compound to compensate shrinkage. Finally cover the bevel portion with any suitable overall skin coat with a desired full surface-leveler material).

**26.37.2.3 Measurement:**

The length and breadth of fibre cement board shall be measured in any one face, correct to the nearest cm and area worked out in square metres correct to two places of decimal.

**26.37.2.4 Rate:**

The rate shall include the cost of materials and labour involved in all the operations described above. Nothing extra shall be paid for fixing arrangement i.e. drilling, nut & bolts, filling groove etc.(cost of frame work to be paid for separately).

**26.38 INTERNAL WALL PANELS ON LIGHT GAUGE STEEL FRAME WORK WITH 12.5MM THICK GYPSUM PLASTER BOARD**

**26.38.1 For Cement Fibre Board**

**26.38.1.1 Nominal Length and Width**

Flat fibre cement sheets shall be available in nominal lengths up to 3 000 mm and nominal widths up to 1240 mm.

**26.38.1.2 Min. Modulus of Rupture:** For 8 mm :10 MPA

**26.38.1.3 Thickness:** Flat fibre cement sheets shall be 8 mm.

**26.38.1.4 Tolerances on Dimensions:** Tolerances on nominal dimensions shall be as follows:

(a) On length and width (indicated by d)

$d \leq 1000 \text{ mm} :$   $\pm 5\text{mm}$

$1000 \text{ mm} < d \leq 1600 \text{ mm}:$   $\pm 0.5 \text{ percent}$

$d > 1600 \text{ mm} :$   $\pm 8\text{mm}$

These tolerances do not apply to oversize sheets.

(c) On thickness, e :

$e \leq 6\text{mm}:$   $\pm 0.6\text{mm}$

$e > 6\text{mm}:$   $\pm 10\text{percent}$

For sheets without texture on the exposed face, the maximum difference between extreme values of the thickness measurements within one sheet shall not exceed 15 percent of the maximum measured value

**26.38.1.5 Tolerances on Shape**

Straightness of edges: The tolerance on the straightness of edges shall be 3 mm/m for the relevant dimension (length or width) when measured in accordance with the method given  
Squareness of edges: The tolerance on the squareness of sheets shall be 4 mm/m when measured in accordance with the method given.

**26.38.1.6 Acceptance Tests**

The objective of an acceptance test is to establish whether a batch of products conforms to a specification. The tests shall be performed on samples drawn either from continuous production or



from a consignment (see also 8). The acceptance test shall be carried out at the manufacturer's works on sheets and test specimens cut from sheets as delivered. The following acceptance tests shall be carried out:

- (a) Dimensional and geometrical characteristics (compulsory) ,
- (b) Bending strength (compulsory) , and
- (c) Apparent density (compulsory).

#### **26.38.1.7 Method For Testing**

As per IS 14862 2000

### **26.38.2 For Gypsum Plaster Board**

#### **26.38.2.1 Gypsum Plaster Board**

Gypsum Plaster Board shall conform to IS 2095.

Gypsum plaster shall conform to IS 2547 (Part 1). Byproduct gypsum conforming to the requirements of IS 12679 shall also be used for the preparation of plaster.

Requirements, tests, sampling, finishing etc of Gypsum Plaster Board shall be as per IS 2095.

#### **26.38.2.2 Fixing**

Fixing the 12.5mm thick gypsum plaster board on 8mm thick fiber cement board with self-drilling / tapping screws / fasteners @ 60cm c/c of approved make, Screws shall be of counter sunk rib head of 1.60mm to 4 mm thick of 8 to 10 gauge of length varying from 25 to 45 mm. Proper taping and jointing to be done using fiber mesh tape and epoxy and acrylic based jointing compound for seamless finish.

Fill the groove (i.e. 2-3mm gap between boards),taping and jointing 8mm thick fiber cement board and 12.5mm thick gypsum plaster boards with epoxy based sealing compound, Acrylic based sealing compound, Non woven reinforcement Tape as per direction of Engineer in charge.(Use a flexible knife so that no air bubble is entrapped. Allow 1-2 hours gap. Once hard tacky or set, apply a coat of Acrylic based sealing compound paste to flash fill the beveled area. After 2-4 hours go on to repeat a skin coat with Acrylic based sealing compound to securely embed the 40mm width (non woven reinforcement Tape. Use only flexible steel knife, such as provided with packs, to avoid air entrapment within compound. After overnight drying shrinkage apply a coat of acrylic based sealing compound to compensate shrinkage. Finally cover the bevel portion with any suitable overall skin coat with a desired full surface-leveler material).

#### **26.38.2.3 Measurement:**

The length and breadth of fibre cement board shall be measured on one face,correct to the nearest cm and area worked out in square metres correct to two places of decimal.

#### **26.38.2.4 Rate:**

The rate shall include the cost of materials and labour involved in all the operations described above. Nothing extra shall be paid for fixing arrangement i.e. drilling, nut & bolts, filling groove etc.

### **26.39 EXTERIOR FACE PANELS BREATHABLE VAPOUR BARRIER UNDERNEATH THE CEMENT FIBER BOARD**

#### **26.39.1 General**

Vapour diffusion will occur through exterior face panels where there is difference of vapour pressure between interior and exterior of the building. Vapour flows from high vapor pressure to low vapor pressure area.

In colder climates, cold outdoor contains little moisture and moisture it does contain will be at low Pressure, so net vapor flow is generally inside to outside. In warmer climates the reverse is true, so the net vapour flow is from outside to inside of building. Therefore, in warmer climates, exterior elements are typically more resistant to vapor flow. So the breathable vapor barrier shall be fixed on the exterior face of panels.

It shall be used to control water vapor diffusion through the wall. It Building exterior require this, so that water condensation is minimized within wall assemblies otherwise Condensation can lead to deterioration of the structure and mold growth.

#### **26.39.2**

Some common vapour barriers include polyethylene, aluminium foil, some rubber membranes, and polyurethane coatings.

The material shall be chosen on the basis of the property called "permeance". It is the maximum rate of water vapour that can pass through a vapour barrier. As per NBCC (National Building code of Canada), the maximum permeance shall be 1 perm ( 60 Nano gram per second per square meter per pascal)

#### **26.39.3 Measurement:**

The length and breadth of vapour barrier shall be measured on one face, correct to the nearest cm and area worked out in square metres correct to two places of decimal.

#### **26.39.4 Rate:**

The rate shall include the cost of materials and labour involved in all the operations described above. Nothing extra shall be paid for fixing arrangement.

### **26.40 MOISTURE RESISTANT/FIRE RESISTANT 6 MM THICK FIBER CEMENT BOARD**

**26.40.1** The specification for fibre cement board shall be as per 26.37.1.

#### **26.40.2 Fixing**

Fixing the moisture resistant/ fire resistant 6mm thick fibre cement board (High Pressure Steam cured) with necessary accessories & GI self drilling/ tapping screws etc., of required size(Screws shall be of counter sunk rib head of 1.60mm to 4 mm thick of 8 to 10 gauge of length varying from 25 to 45 mm), and filling the groove (i.e. 2-3mm gap between boards),taping and jointing of the first layer 6mm and 9mm thick fiber cement boards with epoxy based sealing compound or with silicon sealant. Second layer is fixed over it in a staggered pattern, with suitable arrangement as per approval of Engineer-in-charge.

#### **26.40.3 Measurement:**

The length and breadth of fibre cement board shall be measured correct to the nearest cm and area worked out in square metres correct to two places of decimal.

#### **26.40.4 Rate:**

The rate shall include the cost of materials and labour involved in all the operations described above. Nothing extra shall be paid for fixing arrangement i.e. drilling, nut & bolts, filling groove etc.

### **26.41 GLASS FIBRE REINFORCED GYPSUM (GFRG) PANEL**

**26.41.1 Materials:**

### **26.41.1.1 GFRG panel**

Glass Fiber Reinforced Gypsum is a building panel made-up of calcined gypsum plaster, reinforced with glass fibers.

#### **Grade and Type:**

Class 1- Water Resistant grade – Panels that shall be used for external walls, in wet areas and/or as floor and wall formwork for concrete filling.

Class 2 – General grade - panels that shall be used structurally or non-structurally in dry areas. These panels are generally unsuitable for use as wall or floor formwork.

Class 3 – Partition grade – panels that may only be used as non- structural internal partition walls in dry areas only.

#### **Dimension**

Typical Dimension of GFRG building panel is 12.0m x 3.0m x 0.124m. Each 1.0m segment of the panel contains four cells. Each cell is 250mm wide and 124mm thick containing a cavity of 230 mm x 94 mm. The various cells shall be inter- connected by solid 'ribs' (20 mm thick) and 'flanges' (15 mm thick), comprising gypsum plaster, reinforced with 300 - 350 mm glass fiber roving, located randomly but centrally. The weight of panel shall be 40kg / sqm and density is 1140 kg/m<sup>2</sup>.

#### **26.41.1.2 Infill:**

M25 concrete at initial 50mm thickness and thereafter with quarry dust mixed with 5% cement (by volume) in three stages each after 90 minute interval.

#### **26.41.1.3 Weld mesh:**

10 gauge weld mesh of size 100mm x 100 mm for floor/roof slab concrete screed over the micro beams as reinforcement.

#### **26.41.1.4 Joint sealant:**

Joint filling sealant compound with grout RW/or equivalent.

#### **26.41.1.5 Water Proofing:**

Water proofing of vertical joints between door/windows/ventilators frames by Zycosil/equivalent & Zycoprime/equivalent solution.

### **26.41.2 Construction Procedure**

#### **26.41.2.1 GFRG Panel**

As per the building plan and design, each wall panel shall be cut at the factory using an automated cutting saw. Door/window/ventilator and openings for AC unit etc. shall also be cut and panels for every floor marked as per the building drawing. Panels are vertically loaded at the factory on stillages for transportation to the construction site on trucks. Panels shall be erected over the RCC plinth beam and concrete is infilled from top. All the panels shall be erected as per the building plan by following the notation.

#### **26.41.2.2 Erection:**

Each panel shall be erected level and plumb and shall be supported by lateral props to keep the panel in level, plumb and secure in position. Embedded RCC lintels shall be provided wherever required by cutting open external flange. Reinforcement for lintels and RCC sunshades shall be provided with required shuttering and support. All GFRG wall panels at the ground floor are to be erected over a network of RC plinth beams supported on suitable foundation. For providing embedded micro beams, top flange of the respective cavity is cut and removed in such a way that minimum 25

mm flange on both end is protruded . RC concrete screed of minimum 50 mm thickness is provided above the GFRG floor panel, which is reinforced with weld mesh of minimum size of 10 gauge 100 mm × 100 mm. This RC screed and micro beam act together as series of embedded T beams. The thickness of the RC screed, reinforcement and interval of embedded RC micro beams depends on the span and intensity of imposed load. The connectivity between the horizontal tie beam, embedded RC micro beams, concrete screed and vertical rods in GFRG wall, and ensures perfect connection between floor/roof slab and walling system.

The procedure of Erection of panel shall be as follow:

- 1) Align the wall by marking with chalk line, where wall is to be erected.
- 2) Then fix the hold fast (regular door frame hold fast of 150mm) by plumbing wall. Two nos. of hold fasts are required for each panel.
- 3) Simultaneously cut the pocket of electrical points & electrical conduits to be inserted inside cavity of Rapid wall.
- 4) Then erect the panel by supporting with props.
- 5) Fix electrical switch boxes.
- 6) Fix other panels same as per the above method up to required length
- 7) Check the plumb & line of the wall.
- 8) Fill the holdfast gap with concrete.
- 9) Finish the joints of two panels by fixing fiber tape with stucco as follow:
  - (i) Make a slot of 8mm wide & 2mm deep at the joint of panel.
  - (ii) Fix the jointing fiber tape and finish the surface with stucco.
- 10) Joints of panel with RCC column/ beam shall be finished by stucco with reinforcing fiber of used cement bags.
- 11) Finish the gap around electrical points and between panel & slab/beam by stucco.

#### **26.41.2.3 Reinforcement:**

Reinforcement for micro-beams shall be placed and weld mesh as reinforcement is placed. Concrete is poured for micro-beams and RCC slab. These should results in the embedded RCC micro beams and 50 mm thickness screed concrete become a series of “T” beams. Erection of wall panel and floor slab for upper floor can be arranged the following day. Vertical reinforcement of floor below is provided with extra length so as to protrude to 0.45 m to serve as start up rods and lap length for upper floor. Once the wall panels are erected on the upper floor, vertical reinforcement rods are provided, door/window frames fixed and RCC lintel cast.

#### **26.41.2.4 Concrete infill:**

After inserting vertical steel reinforcement as per the structural design and clamps for wall corners are in place to keep the wall panels in perfect position, concrete having 12mm aggregate shall be poured from the top into the cavities using a small hose to go down at least 1.5 to 2 m into the cavities for directly pumping the concrete from ready mixed concrete truck. For small building construction, concrete can be poured manually using a funnel. Filling the panels with concrete shall be done in three layers of 1m height with an interval of 90 minute between each layer. There is no need to use vibrator because gravitational pressure acts to self compact the concrete inside the water tight cavities.

#### **26.41.2.5 Embedded RCC tie beam all around at each floor/roof slab level:**

An embedded RCC tie beam to floor slab is to be provided at each floor slab level, as an essential requirement of national building code against earth quakes. For this, web portion to required beam depth at top shall be cut and removed for placing horizontal reinforcement with stirrups and concreted. GFRC panel for floor/ roof slab in combination with RCC for floor/roof slab shall also be cut to required size and marked with notation. First the wall joints and other cavities and horizontal RCC tie beams are in- filled with concrete; then wooden plank of 0.3 to 0.45 m wide is provided to room span between the walls with support wherever embedded micro beams are there; finally roof panels shall be lifted by crane using strong sling tied at mid-diagonal point, so that panel will float perfectly horizontal. Each roof panel is placed over the wall in such a way that there shall be at least a gap of 40 mm. This is to enable vertical rods to be placed continuously from floor to floor and provide monolithic RCC frame within GFRC panel. Wherever embedded micro-beams are there, top flanges of roof panel are cut leaving at least 25mm projection.

#### **26.41.2.6 GFRG panel for floor/roof slab in combination with RCC**

GFRG panel for floor/roof slab shall be cut to required size and marked with notation. First, wall joints, other cavities and horizontal RCC tie beams are in-filled with concrete; then wooden plank 0.3 to 0.45m wide shall be provided to room span between the walls with support wherever embedded micro beams are there and then roof panels shall be lifted by crane. Each roof panel shall be placed over the wall in such a way that there will be a gap of at least 40mm. This is to enable vertical rods to be placed continuously from floor to floor and provide monolithic RCC frame within GFRG panel. Wherever embedded micro-beams are there, top flanges of roof panel shall be cut leaving at least 25mm projection. Reinforcement and weld mesh is placed for micro beams and then concrete shall be poured for micro beams and RCC slab.

#### **26.41.2.7 Erection of wall panel and floor slab for upper floor**

Vertical reinforcement of floor below shall be provided with extra length so as to protrude to 0.45m to serve as start up rods and lap length for upper floor. Once the wall panels are erected on the upper floor, vertical reinforcement rods, door/window frames fixed and RCC lintels shall be casted. Then concrete where required and joints shall be filled. Thereafter, RCC tie beams all around shall be concreted.

#### **26.41.2.8 Waterproofing:**

Water proofing treatment of Vertical joints (of external side and internal side) between door frame, window & ventilator frames (on all four sides) of outer wall over the Zycosil/equivalent & Zycoprime/equivalent solution already applied(before the installation of door / window / ventilator frames in position) and fine finish with Grout RW/equivalent. Water proofing treatment of RCC sunshade with Zycosil/equivalent water proofing Solution (1 litre of Zycosil/equivalent& 20 litres of water stirred first & 2 litres of Zycoprime/equivalent added and stirred (total 23 litres)) till it meets the saturation level and testing as per RILEM or by water drops test in which water drops do not absorb but drops remain or rolls.

#### **26.41.2.9 Sealing of joints :**

In-filling / sealing of joint between RCC lintel cum sunshade and wall (on external side) in all floors by pushing in Grout RW/equivalent in paste form and coving 20 mm x 20 mm after applying a coat of Zycosil/equivalent & zycoprime/equivalent solution before cement plastering of top, bottom and sides of RCC sunshade.

The Quality Assurance Plan for GFRG Panel mentioned in Table 26.9

Table 26.9  
**Material Testing**  
Quality Assurance Plan for GFRG Panel

| S. No.                         | Parameters to be inspected                            | Requirement Specified  | Test Method As per BMBA PC-3:2011 | Frequency of Testing       |
|--------------------------------|---|--|-----------------------------------|----------------------------|
| <b>A. Rapidwall/GFRG Panel</b> |   |  |                                   |                            |
| 1.                             | Visual Appearance                                     | Shall be free from defects like cracks, corrugations, ripples, stains, pockmarks, loose corners etc.                               | Clause10.4.1                      | Once in every ten panels   |
| 2.                             | Overall Dimensional Tolerances                        | Length & height shall be within tolerance limit of $\pm 3\text{mm}$ & thickness $+3\text{mm}$ to $0\text{mm}$                      | Clause10.4.2                      | Once in every fifty panels |
| 3.                             | External Skin thickness tolerance                     | Shall be $\pm 3\text{mm}$ (General /Water resistance grade)<br>Min 8mm Partition grade   | Clause10.4.2                      | Once in every fifty panels |
| 4.                             | Internal Rib thickness tolerance                      | Shall be $\pm 2\text{mm}$ (General /Water resistance grade)<br>Shall be $\pm 5\text{mm}$ (Partition grade)                         | Clause10.4.2                      | Once in every fifty panels |
| 5.                             | Cavity Width & Depth Tolerance                        | Shall be $\pm 3\text{mm}$ (General / Water resistance grade)<br>Shall be $\pm 7\text{mm}$ (Partition grade)                        | Clause10.4.2                      | Once in every fifty panels |
| 6.                             | Unevenness  | Shall be less than 1mm (Side A)<br>Shall be less than 3mm (Side B)   | Clause10.4.2                      | Once in every fifty panels |
| 7.                             | Panel weight  | Shall be $40 \text{ Kg/m}^2 \pm 6\%$ (Class 1 & 2)<br>shall be $40 \text{ Kg/mm}^2 \pm 15\%$ (Class 3)                             | Clause10.4.4                      | Once in every fifty panels |
| 8.                             | Water Content   | Shall be less than 1% (measured immediately after drying process)  | Clause 10.4.3                     | Once in every fifty panels |
| 9.                             | Water Absorption Rate                                 | Shall be less than 5% by weight (after 24 hrs of immersion in water)   | Clause 10.4.5                     | Once in every fifty panels |
| 10.                            | Vertical Load bearing capacity (Compressive strength) | Shall be more than $160 \text{ kN/m}$ (General / Water resistance grade)<br>Shall be more than $90 \text{ kN/m}$ (Partition grade) | Clause 10.4.6                     | Once in every fifty panels |
| 11.                            | Out of plane Flexural capacity (Flexural strength)    | Shall be more than $2.1 \text{ kN/m}$ (General /Water resistance grade)<br>Shall be more than $1.3 \text{ kN/m}$ (Partition grade) | Clause 10.4.7/<br>Clause 10.4.8   | Once in every fifty panels |

|                         |   |  |                         |  |
|-------------------------|---|--|-------------------------|--|
| 12.                     | “ U” Value  | Shall be 2.85W/M <sup>2</sup> C  | IS3346:1980             | Once in a year or when the composition changes and initially at the time of approval |
| 13.                     | Thermal Conductivity (K)                            | Shall be 0.617 W/m C   | IS3346:1980             |  |
| 14.                     | Sound transmission                                  | Shall be 40 (STC)  | ISO 140-3:1996          |  |
| 15.                     | Durability<br>i. wetting & drying<br>ii. Salt spray | Average compressive strength shall not be less than 7.52 N/mm <sup>2</sup><br>Shall not suffer any apparent damage after 20 cycles | Clause10.4.9            | Once in a year or when the composition changes and initially at the time of approval |
| 16.                     | Fire Resistance                                     | Shall withstand 700-1000 <sup>0</sup> C after 4hr  | Clause10.4.10           |  |
| <b>B. Raw Materials</b> |   |  |                         |  |
| 1.                      | Calcined Gypsum                                     | i. Shall be more than 90% as Calcium Sulphate<br>ii. Combined moisture shall not be more than 6.2%                                 | As per Company Standard | i. Once in a day<br>ii. Once in a shift  |
| 2.                      | Ammonium Carbonate                                  | Shall not be less than 99.14% as purity  | As per Company Standard | Once on delivery at site   |
| 3.                      | Glass Roving  | These raw materials are performance based. Test Certificates provided by the manufacturers are verified at the time of delivery.   |                         |  |
| 4.                      | BS-94 M   |  |                         |  |
| 5.                      | Retarder D-50                                       |  |                         |  |

### 26.41.3 Measurement:

All measurement of the area is to be measured correct to a centimeter. The area shall be calculated in square meter correct to two decimal places. No deductions shall be made for making openings for doors, windows, ventilators etc.

### 26.41.4 Rates :

The rates shall include the cost of all materials and labour involved in all the operations described above.

### 26.41.5 Glossory:

Cavity : The internal hollow cores inside the panel are called the cavity .

Panel Length: The panel length is the maximum horizontal dimension of a single wall without vertical joint.

Panel Thickness: The panel thickness is the distance between the external faces of the two external skins.

Height :The panel height is the maximum vertical dimension of a single wall without a horizontal joint.

A and B Side: The smoother side of the GFRG panel cast against the machine bed in the manufacturing process is called the A side. The B side is screeded and is relatively rougher than A side.



## **26.42 GALVANIZED STEEL DECK SHEET ROOFING COVERED WITH CONCRETE**

### **26.42.1 Materials**

#### **26.42.1.1 Galvanized Steel Deck Sheet (Fig 26.14)**

The base metal of plain galvanized sheets and coils shall conform to IS 1079 or IS 513 as the case may be. However, deck sheet shall conform to IS 277:2003. When it is not possible to test the base metal before galvanizing, the base metal may be tested after stripping off the zinc coating. The grade of coating shall be minimum 275 g/sqm.

Galvalume and pre-painted galvalume sheets are not recommended for use in contact with concrete.

#### **26.42.1.2 Shear Connectors (See Fig 26.15 A, 26.15B & 26.15C)**

Shear connectors (Shear studs) at the interface of the concrete and sheet are provided. These shear connectors are embossment in deck sheets as typical pattern unique to each profile.

To ensure friction at the embossments, there should not be any paint or grease on the sheet surface in contact with concrete nor should any vibrating load be permitted to act on the slab until the concrete has set completely.

The length after weld should extend at least 35mm above the top of the main rib of the deck profile. The distance from the deck rib shall be minimum 25mm.

Single connector to be located at the center of beams except at butt joints where connectors to be staggered.

To avoid damaging to decking, connectors to be located along the predetermined lines marked on it.

Minimum Spacing of the connectors shall be 5 times the diameter of shank and maximum shall not be more than 600 or 4 times the depth of slab.

Connectors in pair to have a minimum gap of 4 times the diameter of shank.

#### **26.42.1.3 Wire Mesh**

3 mm wire mesh laid at 100x100 mm grid is to be provided to control the cracking.

#### **26.42.1.4 Edge Trim**

Galvanized edge trim is provided where requested around perimeter and void edges. This edge trim acts as permanent formwork only to support the wet weight of concrete during construction.

### **26.42.2 Finish**

The roof when completed shall be true to lines, and slopes and shall be leak proof.

### **26.42.3 Measurements**

The length and breadth shall be measured correct to a cm. Area shall be worked out in sqm correct to two places of decimal.

The area of roof shall be measured on the flat without allowance for laps and corrugations. Roof with curved sheets shall be measured and paid for separately. Measurements shall be taken on the flat and not girthed.

No deduction in measurement shall be made for opening upto 0.4 sqm and nothing extra shall be allowed for forming such openings. For any opening exceeding 0.4 sqm in area, deduction in measurements for the full opening shall be made and in such cases the labour involved in making these openings shall be paid for separately. Cutting across corrugation shall be measured on the flat and not girthed. No additions shall be made for laps cut through.



#### 26.42.4 Rate

The rate shall include the cost of all the materials and labour involved in all the operations described above including all shear connectors, wire mesh, edge trim, seal, scaffolding, machinery for operations required etc. but excluding the cost of structural steel like beams, columns, joists etc. and concrete of different grade as per design.

### 26.43 PRECAST CONCRETE SOLID BLOCK

#### 26.43.1 Precast Concrete Solid Block Made of C & D Waste

The block shall be machine moulded and should be free from visible cracks, flaws warpage & organic matter.

##### 26.43.1.1 Dimensions

The nominal dimensions of block shall be as follows:

Length: 400 or 600mm

Height: 100mm

Width: 200mm.

Most commonly used size is 400 x 200 x 100mm.

##### 26.43.1.2 Classification

Blocks shall have minimum compressive strength of 10N/mm<sup>2</sup> or 100kgf/cm.

The blocks shall have smooth rectangular faces with sharp corner and shall be uniform in colour.

##### 26.43.1.3 Sampling and Tests

Samples of Blocks shall be subjected to the following tests:

- (a) Block density
- (b) Dimensional tolerance.
- (c) Water absorption.
- (d) Drying shrinkage
- (e) Compressive strength.

**26.43.1.3.1 Sampling:** For carrying out compressive strength, water absorption, and dimensional tests, the samples of blocks shall be taken at random according to the size of lot as given in Table A below. The sample thus taken shall be stored in a dry place until tests are made. For the purpose of sampling, the following definition shall apply.

- (a) **Lot:** A collection of blocks of same class and size, manufactured under relatively similar conditions of production. For the purpose of sampling a lot shall contain a maximum, of 10000 blocks.

In case a consignment has blocks more than 10000 of the same classification and size and manufactured under relatively similar conditions of production, it shall be divided into lots of 10000 Blocks or part thereof.

- (b) **Sample:** A collection of blocks selected for inspection and/or testing from a lot to reach the decision regarding the acceptance or rejection of the lot.
- (c) **Defective:** A block failing to meet one or more of the specified requirements.

**26.43.1.3.2** The samples shall be taken as below:

(i) **Sampling from a Stack:** When it is necessary to take a sample from a stack, the stack shall be divided into a number of real or imaginary sections and the required number of blocks drawn from each section. For this purpose blocks in the upper layers of the stack shall be removed to enable units to be sampled from places within the stack.

**Visual characteristics:** The blocks shall be selected and inspected for ascertaining their conformity to the requirements of the relevant specification. The number of blocks to be selected from a lot shall depend on the size of lot and shall be in accordance of Table A for visual characteristics in all cases and dimensional characteristics if specified for individual blocks.

(ii) **Visual Characteristics:** All the blocks selected above in accordance with Table A shall be examined for visual characteristics. If the number of defective blocks found in the sample is less than or equal to the corresponding number as specified in of Table A the lot shall be considered as satisfying the requirements of visual characteristics, otherwise the lot shall be deemed as not having met the visual requirements.

(iii) **Dimensional Characteristics:** The number of blocks to be selected for inspecting the dimensions and tolerance shall be in accordance with Table A. These blocks will be divided into groups of 20 blocks at random and each of the group of 20 blocks thus formed will be tested for all the dimensions and tolerances. A lot shall be considered having found meeting the requirements of dimensions and tolerance if none of the groups of blocks inspected fails to meet the specified requirements in table 26.10.

**TABLE 26.10**

| No. of blocks in lot | Sample size | No. of samples required to be tested from sample size |                |                |                      |                  |                  |
|----------------------|-------------|---|----------------|----------------|----------------------|------------------|------------------|
|                      |             | Dimensional characteristics                           | Visual defects | Blocks density | Compressive strength | Water absorption | Drying shrinkage |
| 0-10000              | 20          | 20  | 20             | 3              | 8                    | 3                | 3                |

(i) **Scale of Sampling and Criteria for Physical Characteristics:** The lot which has been found satisfactory in respect of visual and dimensional requirements shall be next tested for physical characteristics like block density compressive strength, water absorption, drying shrinkage as specified in relevant material specification. The blocks for this purpose shall be taken at random from those already selected above. The number of blocks to be selected for each of these characteristics shall be in accordance with relevant columns of Table A.

**26.43.1.3.3 Dimensional Tolerances:** The variation in the length of the units shall not be more than  $\pm 5$ mm and variation in height and width of units, not more than  $\pm 3$ mm.

The dimensions of blocks when tested as described above as per procedure described in Appendix A of chapter 6 shall be within the following limits per 20 blocks or locally available size as approved by Engineer-in-charge.

Length 8100 to 7900 mm ( $8000 \pm 100$  mm)

Width 4060 to 3940 mm ( $4000 \pm 60$  mm)

Height 2060 to 1940 mm ( $2000 \pm 60$  mm) for 100 mm high block.

**26.43.1.3.4 Block Density:** The average block density when tested in accordance with the procedure laid down in IS 2585 Part 1-2005 shall not be less than 1800kg/m<sup>3</sup>.

**26.43.1.3.5 Compressive Strength:** The blocks, when tested in accordance with the procedure laid down in IS 2185 (part-1) shall have a minimum average compressive strength of 10N/mm<sup>2</sup>.

**26.43.1.3.6 Water Absorption:** The average water absorption of blocks when tested in accordance with the procedure laid down in IS 2185 part 1- 2005 shall be not more than 10% by weight.

**26.43.1.3.7 Drying Shrinkage:** The average drying shrinkage of block when tested in accordance with the procedure laid down in IS 2185 part 1- 2005 shall not be more than 0.1%

## **26.43.2 Block Work**

### **26.43.2.1 Mortar**

The mortar for the C&D waste block work shall be as specified, and conform to accepted standards. Lime shall not be used where reinforcement is provided in block work.

### **26.43.2.2 Soaking of Blocks**

Blocks shall be soaked in water before use for a period for the water to just penetrate the whole depth of the blocks. Alternatively blocks may be adequately soaked in stacks by profusely spraying with clean water at regular intervals for a period not less than six hours. When the blocks are soaked they shall be removed from the tank sufficiently early so that at the time of laying they are skin-dry. Such soaked blocks shall be stacked on a clean place where they are not again spoiled by dirt earth etc.

**Note I:** The period of soaking may be easily found at site by a field test in which the blocks are soaked in water for different periods and then broken to find the extent of water penetration. The least period that corresponds to complete soaking will be the one to be allowed for in construction work.

**Note II:** If the blocks are soaked for the required time in water that is frequently changed the soluble salt in the blocks will be leached out, and subsequently efflorescence will be reduced.

### **26.43.2.3 Laying**

**26.43.2.3.1** Blocks shall be laid in single Block masonry, blocks shall be laid in stretcher bond. Half or cut blocks shall not be used except as closer where necessary to complete the bond. Closers in such cases, shall be cut to the required size and used near the ends of the wall.

Block work for wall thickness 200mm shall be done with block laid flat with its height (100mm) vertical. It shall be done with cement mortar 1:6 (1 cement: 6 coarse sand) Block work for wall thickness 100mm shall be done with the same block laid such that its height of 100mm being horizontal. It shall be done with cement mortar 1:4 (1cement: 4 coarse sand).

**26.43.2.3.2** All loose materials, dirt and set lumps of mortar which may be lying over the surface on which block work is to be freshly started, shall be removed with a wire brush and surface wetted. Blocks shall be laid on a full bed of mortar, when laying, each block shall, be properly bedded and set in position by gently pressing with the handle of a trowel. Its inside face shall be buttered with mortar before the next block is laid and pressed against it. Joints shall be fully filled and packed with mortar such that no hollow space are left inside the joints.

**26.43.2.3.3** The walls shall be taken up truly in plumb or true to the required batter where specified. All courses shall be laid truly horizontal and all vertical joints shall be truly vertical. Vertical joints in

the alternate course shall come directly one over the other. Quoin, Jambs and other angles shall be properly plumbed as the work proceeds. Care shall be taken to keep the perpends properly aligned within following maximum permissible tolerances :

- (a) Deviation from vertical within a storey shall not exceed 6 mm per 3 m height.
- (b) Deviation in verticality in total height of any wall of building more than one storey in height shall not exceed 12.5 mm.
- (c) Deviation from position shown on plan of any block work shall not exceed 12.5 mm.
- (d) Relative displacement between load bearing wall in adjacent storeys intended to be vertical alignments shall not exceed 6 mm.
- (e) A set of tools comprising of wooden straight edge, masonic spirit levels, square, 1 metre rule line and plumb shall be kept on the site of work for every 3 masons for proper check during the progress of work.

**26.43.2.3.4** All quoins shall be accurately constructed and the height of block courses shall be kept uniform. This will be checked using graduated wooden straight edge or storey rod indicating height of each course including thickness of joints. The position of damp proof course, window sills, bottom of lintels, top of the wall etc. along the height of the wall shall be marked on the graduated straight edge or storey rod. Acute and obtuse quoins shall be bonded, where practicable in the same way as square quoins. Obtuse quoins shall be formed with squint showing three quarters block on one face and quarter block on the other.

**26.43.2.3.5** The block work shall be built in uniform layers.

No part of the wall during its construction shall rise more than one metre above the general construction level. Parts of wall left at different levels shall be raked back at an angle of 45 degrees or less with the horizontal. Toothing shall not be permitted as an alternative to raking back. For 100mm block partition to be keyed into main walls, indents shall be left in the main walls.

**26.43.2.3.6** All pipe fittings and specials, spouts, hold fasts and other fixtures which are required to be built into the walls shall be embedded, as specified, in their correct position as the work proceeds unless otherwise directed by the Engineer-in-Charge.

**26.43.2.3.7** To facilitate taking service lines later without excessive cutting of completed work, sleeves (to be paid separately) shall be provided, where specified, while raising the block work. Such sleeves in external walls shall be sloped down outward so as to avoid passage of water inside.

**26.43.2.3.8** Top of the block work in coping and sills in external walls shall be slightly tilted. Where block coping and sills are projecting beyond the face of the wall, drip course/throating (to be paid separately) shall be provided where indicated.

**26.43.2.3.9** Care shall be taken during construction that edges of jambs, sills and projections are not damaged in case of rain. New built work shall be covered with gunny bags or tarpoulin so as to prevent the mortar from being washed away. Damage, if any, shall be made good to the satisfaction of the Engineer-in-Charge.

**26.43.2.3.10** Horizontal reinforcement in the form of MS bars, 2 Nos, 6 mm dia each shall be provided at every alternate third coarse for block masonry of wall thickness 100mm.

**26.43.2.3.11** In retaining walls and the like, where water is likely to accumulate, weep holes, 50 to 75 mm square shall be provided at 2 m vertically and horizontally unless otherwise specified. The lowest weep hole shall be at about 30 cm above the ground level. All weep holes shall be surrounded by loose stones and shall have sufficient fall to drain out the water quickly.

**Note :** Work of providing loose stone will be payable extra.

#### **26.43.2.4 Joints**

Specified thickness of joints shall be of 1 cm.

**26.43.2.4.1 Finishing of Joints:** The face of block work may be finished flush or by pointing. In flush finishing either the face joints of the mortar shall be worked out while still green to give a finished surface flush with the face of the block work or the joints shall be squarely raked out to a depth of 1 cm while the mortar is still green for subsequently plastering. The faces of block work shall be cleaned with wire brush so as to remove any splashes of mortar during the course of raising the block work. In pointing, the joints shall be squarely raked out to a depth of 1.5 cm while the mortar is still green and raked joints shall be brushed to remove dust and loose particles and well wetted, and shall be later refilled with mortar to give ruled finish. Some such finishes are 'flush', 'weathered', ruled, etc.

#### **26.43.2.5 Curing**

The block work shall be constantly kept moist on all faces for a minimum period of seven days. Block work done during the day shall be suitably marked indicating the date on which the work is done so as to keep a watch on the curing period.

#### **26.43.2.6 Scaffolding**

Shall be as specified in clause 6.2.7.

#### **26.43.2.7 Measurements**

**26.43.2.7.1** Block work with 200mm wall thickness shall be measured in cubic metres unless otherwise specified. Any extra work over the specified dimensions shall be ignored. Dimensions shall be measured correct to the nearest 0.01 m i.e. 1 cm. Areas shall be calculated to the nearest 0.01 sqm. and the cubic contents shall be worked out to the nearest 0.01 cubic metres.

**26.43.2.7.2** Block work shall be measured separately in the following stages:

- (a) From foundation to floor one level (Plinth level)
- (b) Plinth (floor one) level to floor two level
- (c) Between two specified floor levels above floor two level

**Note :** (i) Block work in parapet walls, mumty, lift machine room and water tanks constructed on the roof upto 1.2 m height above roof shall be measured together with the corresponding work of the floor next below.

**26.43.2.7.3** No deductions or additions shall be done and no extra payment made for the following :

**Note :** Where minimum area is defined for deduction of an opening, void or both, such areas shall refer only to opening or void within the space measured.

- (a) Ends of dissimilar materials (that is, joists, beams, lintels, posts, girders, rafters, purlins, trusses, corbels, steps, etc.); up to 0.1 m<sup>2</sup> in section;
- (b) Opening up to 0.1 m<sup>2</sup> in area (see Note);

- (c) Wall plates, bed plates, and bearing of slabs, chajjas and the like, where thickness does not exceed 10 cm and bearing does not extend over the full thickness of wall;
- (d) Cement concrete blocks as for hold fasts and holding down bolts;
- (e) Iron fixtures, such as wall ties, pipes upto 300 mm diameter and hold fasts for doors and windows; and
- (f) Chases of section not exceeding 50 cm in girth.
- (g) Bearing portion of drip course, bearing of moulding and cornice.

**Note :** In calculating area of an opening, any separate lintel or sills shall be included with the size of the opening but end portions of lintel shall be excluded. Extra width of rebated reveals, if any, shall also be excluded.

**26.43.2.7.4** Walls 100 mm thick and less shall each be measured separately in square metres stating thickness.

**26.43.2.7.5** String courses, projecting pilasters, aprons, sills and other projections shall be fully described and measured separately in running metres stating dimensions of each projection.

**26.43.2.7.6** Square or rectangular pillars shall be measured separately in cubic metres in multiple of 100mm thick block wall.

**26.43.2.7.7** Circular pillars shall be measured separately in cubic metres as per actual dimensions.

**26.43.2.7.8** Block work curved on plan shall be measured like the block work in straight walls and shall include all cutting and wastage of Blocks, tapered vertical joints and use of extra mortar, if any. Block work curved on plan to a mean radius not exceeding six metres shall be measured separately and extra shall be payable over the rates for Block work in straight walls. Nothing extra shall be payable if the mean radius of the block work curved in plan exceeds six metres.

**26.43.2.7.9** Tapered walls shall be measured net as walls and extra payment shall be allowed for making tapered surface for block work in walls.

#### **26.43.2.8 Rate**

The rate shall include the cost of materials and labour required for all the operations described above except the reinforcement and its encasement in cement mortar or cement concrete. The rate shall also include the following:

- (a) Raking out joints or finishing joints flush as the work proceeds;
- (b) Preparing tops of existing walls and the like for raising further new Block work.
- (c) Rough cutting and waste for forming gables, splays at eaves and the like.
- (d) Leaving holes for pipes upto 150 mm dia. and encasing hold fasts etc.
- (e) Rough cutting and waste for Block work curved in plan and for backing to stone or other types of facing.
- (f) Embedding in ends of beams, joists, slabs, lintels, sills, trusses etc.
- (g) Bedding wall plates, lintels, sills, roof tiles, corrugated sheets, etc. in or on walls if not covered in respective items and
- (h) Leaving chases of section not exceeding 50 cm in girth or 350 sq cm in cross-section.
- (i) Block on edge courses, cut Block corners, splays reveals, cavity walls, Block works curved on plan to a mean radius exceeding six metres.



### **26.43.3 Block Work In Arches**

Block work in arches shall be same as specified in clause 6.3.

### **26.43.4 100mm thick block work**

Block work in 100 mm thick walls shall be done in the same manner as described above in 26.43.2.3 2 Nos. M.S. bars of 6 mm dia., shall be embedded in every third course as given in the item (the dia of bars shall not exceed 8 mm). These shall be securely anchored at their end where the partitions end. The free ends of the reinforcement shall be keyed into the mortar of the main block work to which the 100 mm work is joined. The mortar used for reinforced block work shall be rich dense cement mortar of mix 1:4 (1 cement: 4 coarse sand). Lime mortar shall not be used. Over laps in reinforcement, if any shall not be less than 30 cm.

The mortar interposed between the reinforcement bars and the block shall not be less than 5 mm. The mortar covering in the direction of joints shall not be less than 15 mm.

#### **26.43.4.1 Measurements**

The length and height of the wall shall be measured correct to a cm. The area shall be calculated in sq.m. where 100 mm thick wall is joined to the main walls of 200mm or greater thickness and measurements for 100 mm thick wall shall be taken for its clear length from the face of the thicker wall.

#### **26.43.4.2 Rate**

The rate includes the cost of the materials and labour involved in all the operations described above except reinforcement which is to be paid for separately.

### **26.43.5 HONEY COMB BLOCK WORK**

The honeycomb block work shall be done with specified class of block, laid in specified mortar. All joints and edges shall be struck flush to give an even surface.

The thickness of the block honeycomb work shall be 100 mm thick only, unless otherwise specified. Openings shall be equal and alternate with 100 mm thick block work laid with a bearing of 2 cm on either side.

#### **26.43.5.1 Measurements**

The length and height shall be measured correct to a cm. Area shall be calculated in square metres correct to two places of decimal. Honeycomb openings shall not be deducted.

#### **26.43.5.2 Rate**

The rate includes the cost of materials and labour involved in all the operations described above.

### **26.43.6 Joining old block work with new block work**

**26.43.6.1** In case the height of the blocks of old as well as new work is same, the old work shall be toothed to the full width of the new wall and to the depth of a quarter of block in alternate courses. In case the height of the blocks is unequal, then the height of each course of new work shall be made equal to the height of the old work by adjusting thickness of horizontal mortar joints in the new wall. Where necessary, adjustment shall be made equal to thickness of old wall by adjusting the thickness of vertical joints.

**26.43.6.2** For joining new cross wall to old main walls, a number of rectangular recesses of width equal to the thickness of cross wall, three courses in height and half a block in depth shall be cut in the main walls. A space of the three courses shall be left between two consecutive recesses. The new cross wall shall be bonded into the recesses to avoid any settlement.

**26.43.6.3** Joining of old block work with the new brick work shall be done in such a way that there shall not be any hump or projection at the joint.

**26.43.6.4 Measurement**

The height and thickness of vertical face in contact with new work shall be measured to the nearest 0.01 m and the area shall be calculated to the nearest 0.01 sqm.

**26.43.6.5 Rate**

The rate includes the cost of labour and material involved in all the operations described above.

**26.43.7 Moulding and cornices**

Shall be same as specified in 6.8

**26.43.8 Exposed block work**

Shall be same as specified in 6.10

**26.43.9 Factory Made Cement Concrete interlocking Paver Block Made of C & D Waste**

**26.43.9.1 Base**

Interlocking paver block to be fixed on the bed 50 mm or specified otherwise thick of coarse sand of approved specification and filling the joints with the sand of approved type and quality or as specified and as directed by Engineer-in-charge.

**26.43.9.2 Interlocking Paver Block**

Factory made cement concrete precast paver block of M-30 or otherwise specified grade to be used. Paver blocks to be of approved brand and manufacturer and of approved quality. Paver blocks shall be 60mm thick and made of C&D waste by block making machine with vibratory compaction. Minimum strength as prescribed by manufacturer and as per direction of Engineer-in-Charge for the grade specified to be tested as per method mentioned in specification of subhead cement concrete of CPWD Specification 2019 Vol. I.

**26.43.9.3 Measurement & Rates**

Area provided with paver block to be measured in sqm. correct upto two places of decimal. The rates include the cost of the material, labour, tools etc. required in all the operations described above.

**26.44 PRECAST TECHNOLOGY**

**26.44.1 General**

**26.44.1.0** Design criteria

**26.44.1.1** Design criteria of precast RCC structural units shall conform to the Design requirements of latest version of **IS: 456**.

**26.44.1.2** Resistance to horizontal loading shall be provided by having appropriate moment and shear resisting joints or placing the shear walls. Where shear walls are provided, rotational stiffness of the floor wall joint is not to be considered.

**26.44.1.3** Buttressing in the external walls shall be provided as external wall elements are not fully restrained on both sides by floor panels and that external wall panel connections are the weakest points in a precast panel structure.



**26.44.1.4** In all load bearing elements, adequate restraint shall be provided at corners of the structure. These elements and the external ends of cross wall units should be stiffened either by introducing columns as connecting units or by joining them to non-structural wall units.

**26.44.1.5** Bearing for Precast Units shall be as per clause 8.3 of **IS 15916**.

**26.44.1.6** Slab panels shall be interconnected through joints at regular intervals to provide monolithic/diaphragm action.

**26.44.1.7** RCC decking/ topping reinforced screed shall be overlaid on precast panels for providing rigid diaphragm action, under seismic conditions.

**26.44.2.** Joints:-

Requirements of a structural joint:

**26.44.2.1.** It shall be capable of being designed to transfer the imposed load and moments with a known margin of safety.

**26.44.2.2** It shall accept the loads without marked displacement or rotation and avoid high local stresses.

**26.44.2.3.** It shall accommodate tolerances in elements.

**26.44.2.4** It shall enable the structure to absorb sufficient energy during earthquakes so as to avoid sudden failure of the structure.

**26.44.2.5** Precast Components of the structure shall be designed for fire rating of two hours. Fire rating for joints of the components shall be higher or at least equal to the fire rating of connecting members.

**26.44.2.6** The appearance of precast components joint shall merge with architectural aesthetic appearance and shall not be physically prominent compared to other parts of structural components.

**26.44.2.7** Precast structures may have continuous or hinged connections subject to providing sufficient rigidity to withstand horizontal loading.

When only compressive forces are to be taken, hinged joints may be adopted. In case of prefabricated concrete elements, load is transmitted via the concrete.

When both compressive force and bending moment are to be taken, rigid or welded joints may be adopted. The shearing force is usually small in the column and can be taken up by the friction resistance of the joint. Here load transmissions is accomplished by steel inserted parts together with concrete.

**26.44.2.8.** When considering thermal shrinkage and heat effects, provision of Expansion joints as per **IS 3414** shall be provided.

**26.44.3** Load Testing:

**26.44.3.1** Tests for Components/Structure:

Sampling Procedure: Lot for sampling shall be as per criteria laid down under clause **10.1.1** of **IS 15916**. The lot found satisfactory with respect to the dimensional requirements shall be tested for load test. The lot shall be considered as conforming to the strength requirement, if all the units meet the requirement; otherwise not.

Testing on Individual Components: Test load on the component, duration of applying the test load, maximum deflection & recovery after removal of the test load & test observations shall satisfy the requirements under clause **10.2** of **IS 15916**.

**26.44.3.2** Test on completed structure:

Load testing on a completed structure or part of completed structure should be made, if there is a reasonable doubt of adequacy in strength of the structure. The testing procedure on the structure or part of completed structure as to the quantum of test load, duration of applying of the test load, maximum deflection, and recovery after removal of the test load & other required test observations shall be as per clause 10.3.1 of **IS 15916**.

**26.44.4 Compliance with Design codes:**

**26.44.4 .1** Precast construction is to be undertaken broadly as per relevant BIS/ BS/ ACI codes and standards for Precast constructions **IS: 456, IS:15916, IS 15917, IS: 11447, IS: 10297** etc.

**26.44.5 Manufacturing:** The precast concrete elements shall be manufactured at an established manufacturing facility in a factory with a quality controlled environment where a fully equipped quality laboratory is made available.

**26.44.6 Pre-tensioning Specifications:**

The pre-tensioning of the precast elements, if resorted to, shall be accordance with the applicable standards and the pre tensioning details of each typical element shall be submitted in advance for approval from Engineer-in- Charge.

**26.44.7.**Specifications of the precast elements: The specifications for all the Precast concrete elements should not be lower than the following:

- (a) Grade of concrete: M40 min for precast & M50 min for pre-stressed.
- (b) Reinforcing steel : Fe500D
- (c) Prestressing steel :LRPS – FeP1860 – uncoated
- (d) Cement – OPC 43/53 grade
- (e) 2 hours fire rating for precast walls beams and slabs.
- (f) Smooth finished surfaces for the precast elements

**26.44.8.**Product tolerances: All the pre-stressed precast concrete elements should be manufactured in conformation to the tolerance limits as per the PCI manual.

**26.44.9.**Curing: The curing for precast/ and pre-stressed concrete elements should be as per the applicable IS codes and supporting proof of curing records should be submitted.

**26.44.10.** Quality Assurance: The precast concrete elements should be tested in accordance with the IS or ASTM standards including the following tests:

1. Slump tests.
2. Compressive Strength test
3. Typical element load bearing test

**26.44.11** Transportation of precast elements: Since the construction is planned with precast technology the precast concrete elements from the manufacturing location should not be removed and transported until they attain at least 75% of the required compressive strength of 28 day duration.

**26.44.12** Cranes for Erection: Cranes with at least 1.5 times safety margin along with calibration certification only should be used for carrying out the erection of precast concrete elements at the site.

**26.44.13** Erection of Precast elements: The erection of the pre-stressed precast elements should be done using experienced erection persons and as per the standard methodology and in safe manner in accordance with design sequence ensuring erection tolerances as per the accepted Standards (like PCI Manual).

**26.44.13.1** for all precast/pre stressed elements irrespective of size, shape and thickness, should be provided with proper lifting accessories for loading ,unloading and erection at site, nothing shall be paid on account of this.

**26.44.13.2** pre stressed elements should not be allowed to localized cutting after transporting to site as pre stressed steel may get disturbed.

**26.44.13.3** suitable openings should be provided for all precast/pre stressed elements for inserting dowel bars ,passing the cables etc (Note: the size and shape of opening should as per relevant code provisions.)

**26.44.14** Connections: The precast elements should be given wet connections or alternatively as per the design requirements. All the connection details and details of structural ties should be furnished in advance for review and approval.

**26.44.15** Grouting / Fillings: The grouting/fillings should be done with Premixed, packaged shrink-resistant grout using materials of approved standards and technical specifications in accordance with accepted grouting practices.

**26.44.16** Screeding: The floor constructed with solid / hollow core precast slabs should be covered with concrete screed of required thickness using the same grade as that of precast member and by providing reinforcement for integrating with adjacent precast components and to obtain the monolithic behavior to slab .However the change in grade of concrete from that of base precast members may be accepted depending upon the designer recommendations duly approved and based on the site conditions wherever it so warranted

**26.44.17** Joint Fillings: The joints of the constructed precast elements should be filled with backer rods and weather proof mastic sealants using standard materials and as per the approved methodology.

**26.44.18** Mock-up of precast elements: If required, the contractor should demonstrate mock-up of precast elements and their erection in advance for observation and approval.

**26.44.19** Methodology Statements: Methodology statements for manufacturing of precast elements, transportation, erection, connection, and screeding should be submitted in advance for approval. The methodology statements for safety practices should also be submitted.

**26.44.20** Testing of the Structure: After construction of the structure, the part of it should be loaded with 1.5 times the design load for deflections and other parameters.

**26.44.21** Components of RCC structure shall be designed for loads in accordance with **IS 875 (Parts I to 5)** and **IS 1893-Part 1**. In addition, loads that might be expected during the construction shall also be considered in the design.

**26.44.22** The pre-cast RCC manufacturing unit of pre cast elements shall be got approved from Engineer-in-charge before start of work.

**26.44.22.1** The pre-cast manufacturing unit shall have minimum capacity of 45 cum/hour fully automatic batching plant and having manufacturing capacity of 300sqm/day of prestressed precast hollow core slab & 50 cum/day of solid pre-cast element.

**26.44.22.2** The manufacturing unit of pre cast elements shall be within feasible distance from site so that quality of pre cast elements can be inspected by Engineer-in-charge or his representatives during casting.

**26.44.22.3** The contractor shall at his own expenses furnish all stakes, templates, platforms, equipment, arrange labour that may be required in setting or laying out any part or which of the work. The contractor shall be held responsible for proper execution of the work to such lines and grades as may be established or indicated in the drawings and specifications.

**26.44.22.4** Pre-cast concrete construction (RCC Columns and Hollow core slabs)

- (a) The concrete mix used shall be of min of M-40 grade Ready mix concrete for solid precast elements viz. columns and footings and M-50 grade Ready mix concrete for prestressed hollow core slabs of required size and thickness in accordance **with IS:1343**
- (b) The prestressing of steel strands for manufacture of hollow core slabs shall be done in accordance to the **IS: 1343**.
- (c) Hollow core slabs shall be provided with suitable weep holes wherever necessary
- (d) Contractor shall provide suitable steel shuttering moulds as per drawing to cast the RCC columns with the specified dimensions and tolerances in factory approved by Engineer-in-charge.
- (e) Reinforcement shall be fabricated to the required shape & size and put in the mould as per drawings. Embedded parts, hooks if any shall be placed, anchored properly and aligned as per requirements for which no extra payment shall be made.
- (f) Hollow core slab manufacturing details as per the manufacturer's recommendations satisfying the design intents showing the details of HTS wires, stressing etc shall be submitted prior to actual manufacturing.
- (g) Concrete of specified grade as per the design shown in drawing shall be poured into the form work, compacted and finished to final shape. All the pre-cast elements shall then be sufficiently cured by steam curing method under strict supervision of Engineer-in-charge or his authorized representatives.
- (h) Contractor shall transport the elements columns & footings to the site of the work / location and shall place in position by mechanically operated mobile cranes.
- (i) Contractor shall be responsible for proper handling of the units and will ensure regular supply of precast RCC elements.
- (j) Temporary Openings shall be provided at the base of columns and wall of its form work and other places necessary to facilitate cleaning and inspection.
- (k) Immediately before concrete is placed, all forms shall be carefully inspected to ensure that they are properly placed, sufficiently rigid and tight, thoroughly cleaned, properly treated and free from foreign materials before they are again used. If forms appear to be unsatisfactory in any way either before or during the placing of concrete, the Engineer-in-charge shall have power to stop the work until the defects are corrected.

**26.44.22.5** Transportation and Erection of Pre-cast elements:

- (a) Necessary lifting hooks/holes shall be provided at structurally advantageous points to facilitate demoulding and erection of precast units in accordance with **IS: 10297**
- (b) All the pre cast elements from the manufacturing unit shall be transported by suitable trailer in such a way that pre cast elements are not damaged in during transit.
- (c) Contractor shall ensure that all the corners/edges are properly protected during transportation.
- (d) Damaged elements shall not be allowed to use in the works.
- (e) It shall be ensured that clearance of Engineer-in-charge is obtained prior to erection.
- (f) Erection of all pre cast elements shall be done by telescopic crane of suitable capacity with skilled man power.
- (g) Initially pre cast columns are to be erected in the designated locations to the required level, dimensions and tolerances as per lay out of the approved execution drawing after placement of leveling course of concrete.
- (h) After successful erection of series of columns in a particular stretch, the intermediate panels are to be erected in between the columns by cranes.
- (i) Panels are to be erected vertically without any offsets and suitable rubber packers approved by Engineer-in-charge, shall be provided where ever required for erection purpose for which no extra payment shall be made.

**26.44.23** Documentations: All stages of manufacturers of precast element, i/c prestressing, testing & checking transportation, checking again at site, laying/erection at site, testing etc. shall be documented by the agency and shall be submitted to Engineer-in-charge before passing of final bill.

**26.44.24** Fabrication & Manufacturing of Prestressed Hollow Core slab (Hollow area 25 to 30%) of different thickness & modular width 1200 mm in Controlled Factory Environment with approved methodology, conforming to **IS:10297** by using long line casting method having arrangement of proper steel bed.

Concreting should be done by batch mixing plant capable of producing **zero slump** concrete, transported through automatic shuttels of standard make & laid on bed with the help of extruder/Slip former, finishing, curing and also provision of steam curing. Cutting, making necessary cutout/holes of required sizes for services in slab element after achieving required strength, yard handling & stacking all complete as per approved shop drawings & design mix as per the direction of the Engineer-in-charge.

Note: Less cement used than the specified cement content as per design mix is recoverable. However, nothing extra shall be paid for excess use of cement than the specified. 3.9.1 Concrete Grade M-40 (Cement content 400kg)

**26.44.25.** Fabrication and manufacturing of solid precast concrete element with provisions of shear keys, connecting loops, dowel tubes and proper lifting accessories for walls, beams, slabs, stairs, column etc, of various thickness, shape and size of different concrete grades manufactured in controlled factory environment with approved methodology including moulds (Pallet system, Tilts form, table moulds, battery moulds, vertical moulds, beam moulds, column moulds, staircase moulds, Facade mould, etc.), mixing, transporting and placing of concrete, vibrating, curing, finishing, making necessary cutout/holes of required sizes for services, yard handling & stacking all complete as per **IS 11447** and as per approved shop drawings and design mix as per the direction of Engineer-in-Charge. (Cost of reinforcement, Mechanical, Electrical and Plumbing inserts will be paid separately).

Note: Less cement used than the specified cement content as per design mix is recoverable. However, nothing extra shall be paid for excess use of cement than the specified.

**26.44.26.** Transportation of Precast Elements by flat bed Tractor (Double / Triple axle 40ft Length with proper accessories like A frame etc) from factory, including the cost of loading, unloading & stacking at site with the help of required capacity cranes.

**26.44.27** Erection & Installation of Precast/Prestressed Concrete elements in correct & final position with proper line level and plumb at site making all arrangements (i.e. cranes, push-pull jacks & all another T & P for lifting Placing & Alignment of elements, within erection tolerance as per **IS 15916** as per approved shop drawings and all complete as per the direction of Engineer-in-Charge but excluding the cost of simpads, non shrink grout and steel works i.e hangers.

**Pre-stressing wires shall confirm to IS: 14268.**

RCC in column, Beams, stairs& slabs – all precast members

- (i) Precast external insulated wall panels, 185mm thick with M40 & Fe 500D.
- (ii) Precast internal wall panels, 125mm thick with M40 & Fe 500D.
- (iii) Precast parapet wall panels, 185mm thick with M40 & Fe 500D.
- (iv) Precast beams with M40 & Fe 500D/or prestressed with M50 & prestress steel Fe P1860
- (v) Precast solid slabs, 150mm thick with M40 & Fe 500D/ or prestressed with M50 & prestress steel Fe P1860
- (vi) Precast staircase (150mm riser and 300mm tread width) M40 & Fe 500D or prestressed with M50 & prestress steel Fe P1860
- (vii) Precast solid slabs for ramps, 150mm thick with M40 & Fe 500D or prestressed with M50 & prestress steel Fe P1860
- (viii) Precast columns with M50 & Fe 500D

Pre-cast reinforced concrete units shall be of grade or mix as specified. Provision shall be made in the mould to accommodate fixing devices such as hooks etc. and forming of notches and holes. Each unit shall be cast in one operation. A sample of the unit shall be got approved from Engineer-in-charge before taking up the work.

Pre-cast units shall be clearly marked to indicate the top of member and its location.

Pre-cast units shall be stored, transported and placed in position in such a manner that these are not damaged.

The compaction of the concrete shall be done by vibrating, table or external vibrator, as approved by Engineer-in-charge. The rates include the element for framework and mechanical vibration.

**26.44.28 Measurement:** Dimensions shall be measured nearest to a 0.50 cm The areas shall be worked out nearest to 0.01 Sq. mt. The cubical contents shall be worked out to nearest 0.01 cubic metre.

**26.44.29 Rate**

The rate for item includes cost of all materials. labour, and all operations involved. Cost of M.S. frames, lugs including their welding, lifting hooks is also included. In the item of providing and fixing precast reinforced cement concrete in shelves the cost of cutting chases and making good the same shall be inclusive in the item and nothing extra shall be paid on this account.

## **26.45 SCAFFOLDING NET**

**26.45.1** Scaffolding net of required width made of high density Polyethylene UV stabilized knitted on warp knitting machines having density 100gm/sqm and shading coefficient minimum 75% around the construction site/ for vertical extension as per requirement including fastening/tying with building/ scaffolding pipes or with any other fixtures etc. should be used.

**26.45.2** Net shall be made with a square or diamond mesh. Maximum size of opening shall not exceed 10X10 mm. A continuous length of net having no joints, shall be used to cover the span between the supports. When in use, the net shall have a sag at the centre of not less than one-fifth and preferably not more than one-fourth of the length of the shorter side. The ends of all cords used in the nets shall be secured to prevent unraveling. The maximum vertical distance between the working level and the level at which the safety net is to be used shall be such that it should not hamper the progress of the work or should not make inconvenience to the work force. The work shall be carried out as per **IS-11057**

**26.45.3 Measurement:** One time measurement will be given in square meters for throughout completion of the project including extended time, if any, as per various clauses and per direction of Engineer- in- Charge.

### **26.45.4 Rate:**

Onetime payment shall be made for providing Scaffolding net from start of work till completion of work including shifting if any. The Scaffolding net shall be the property of the contractor on completion of the work



**BAMBOO MAT CORRUGATED SHEET (BMCS)**

Sub Head : 26. New Technologies and Materials  
 Clause : 26.7.2

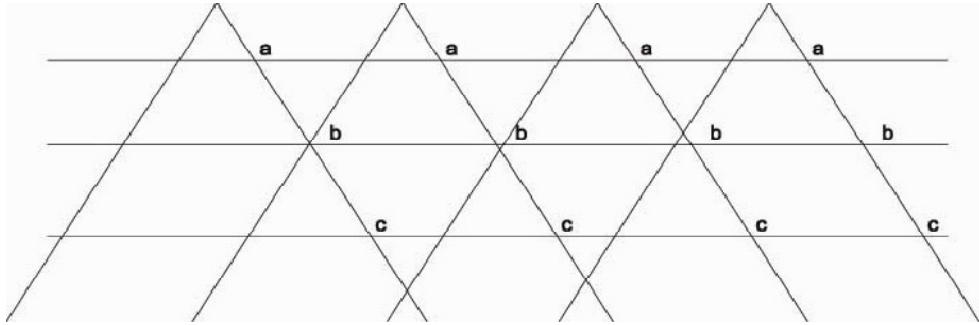


Fig. 26.1

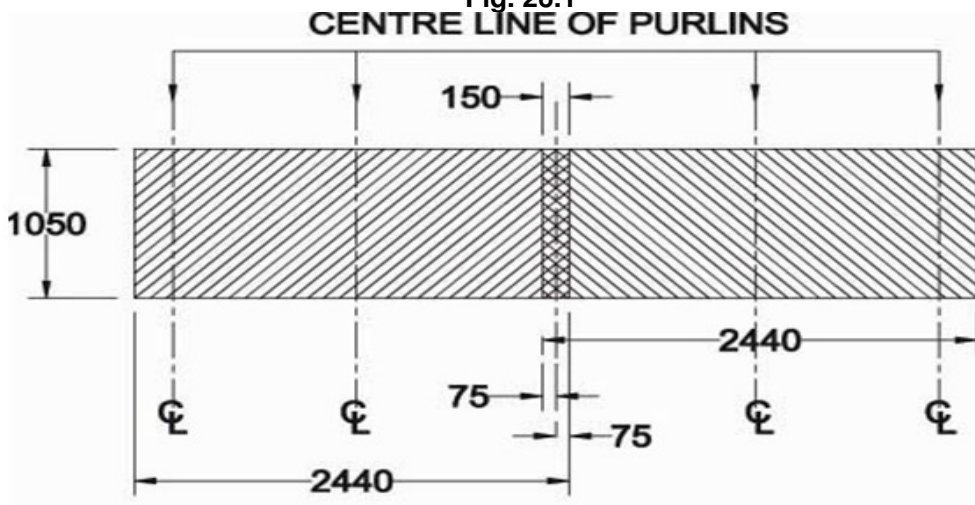
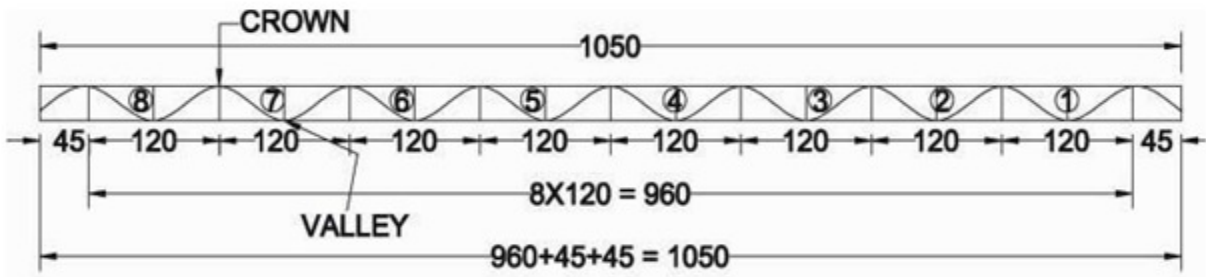


Fig 26.2 End lap of BMCS



CROWN- 09 Nos

VALLEY -08 Nos

Fig. 26.3 Details of Corrugation

**BAMBOO MAT CORRUGATED SHEET (BMCS)**

Sub Head : 26. New Technologies and Materials  
 Clause : 26.7.2



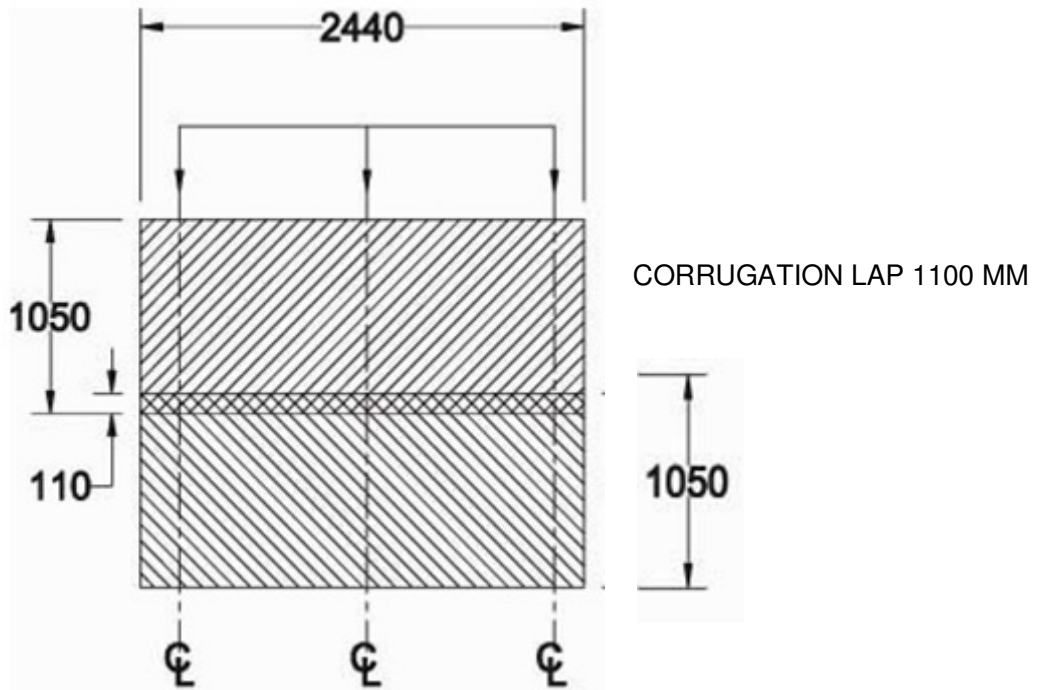


Fig .26.4 Side lap of BMCS

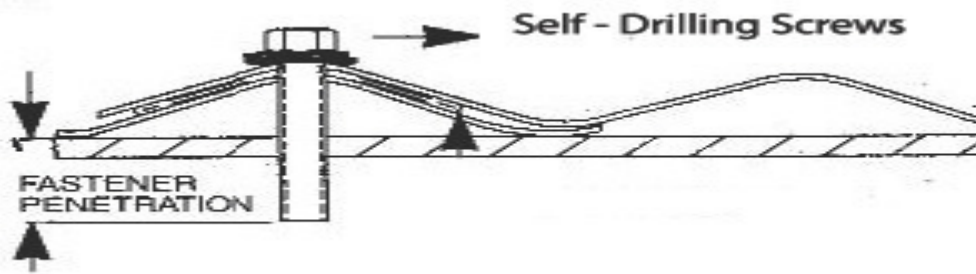


Fig No.26.5

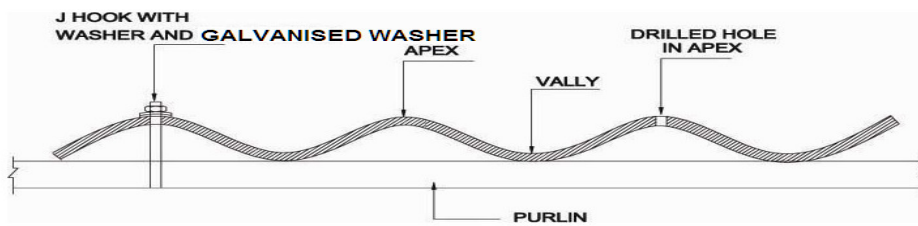


Fig. 26.6

## BAMBOO MAT CORRUGATED SHEET (BMCS)

Sub Head : 26. New Technologies and  
Materials

Clause : 26.7.2

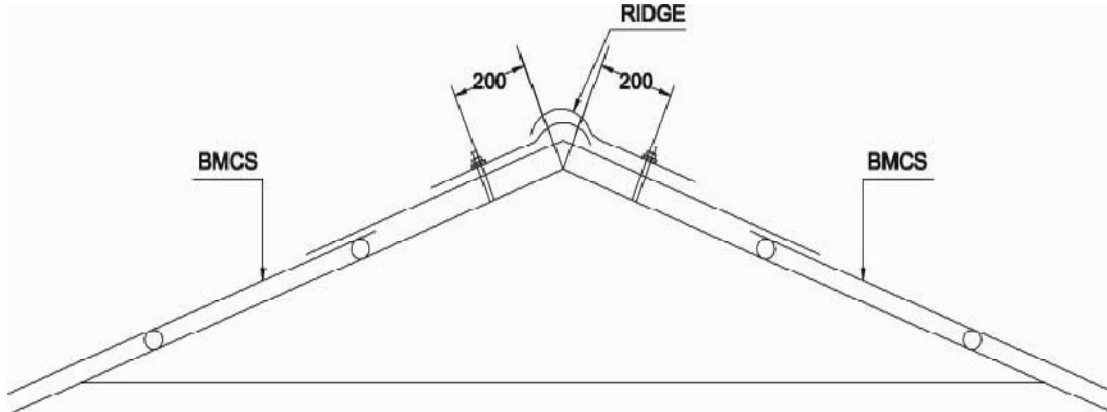


Fig. 26.7 BMRC Ridge purlin

## Cavity wall thermal insulation system with rigid foam insulation

Sub Head : 26. New Technologies  
and Materials

Clause : 26.11.3

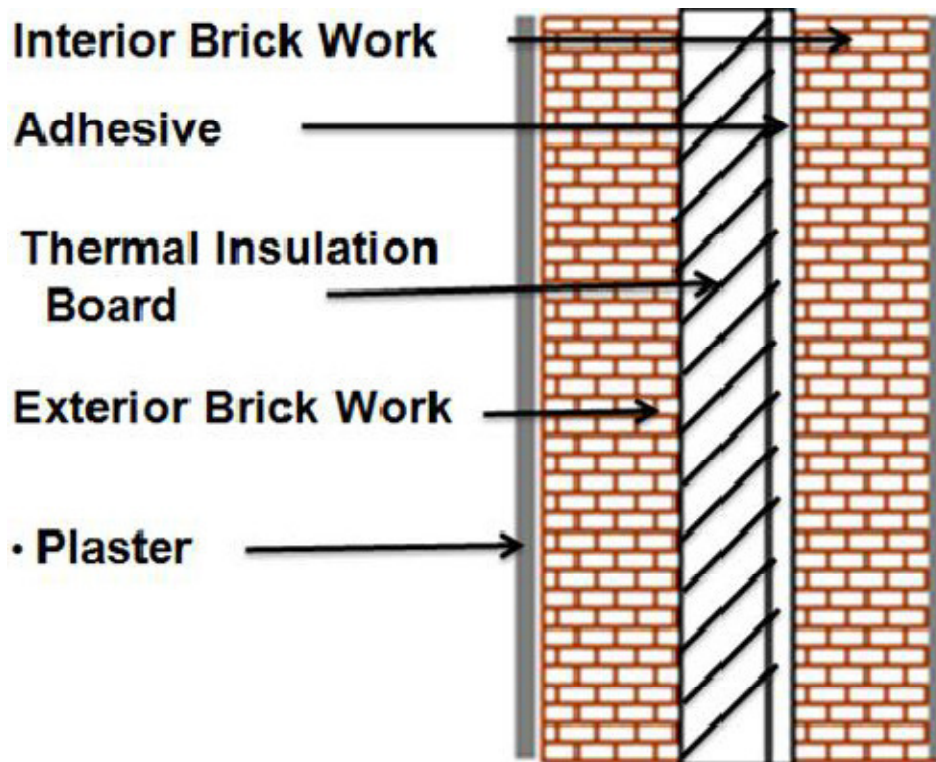
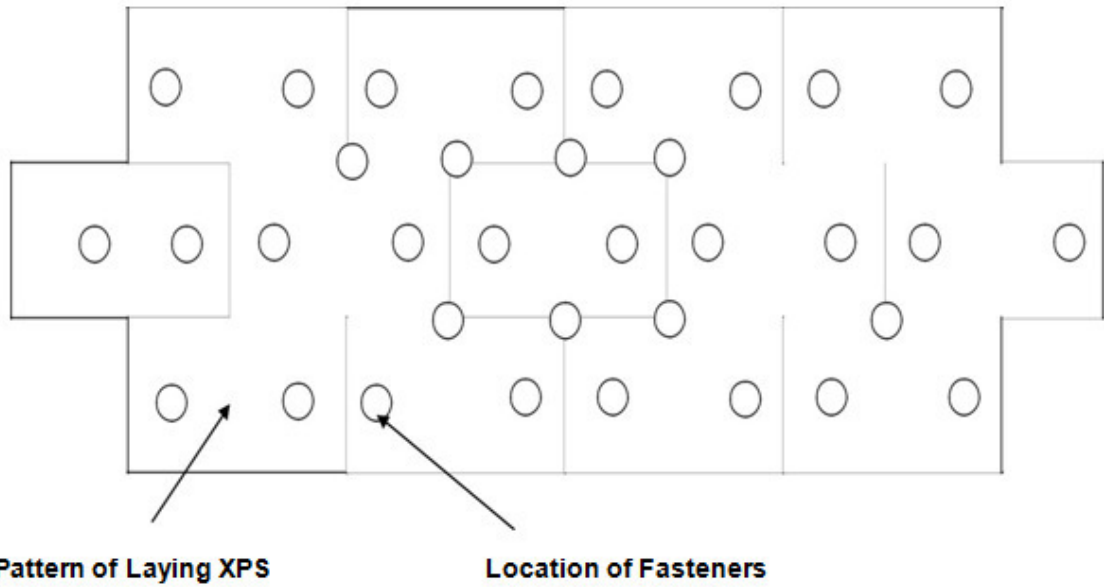


Fig. 26.8 Cavity wall thermal insulation system with rigid foam insulation

**Under Deck insulation system**

**Sub Head : 26. New Technologies  
and Materials  
Clause : 26.12.3**



**Fig. 26.9 Location of Fasteners of extruded Polystyrene Rigid Underdeck insulation.**

## GEOGRIDS

Sub Head : 26. New Technologies  
and Materials

Clause : 26.14.1



Fig.26.10 Extruded Geogrids

Fig.26.11 Coated Woven or knit  
Yarn Geogrids

Fig.26.12 Bonded Strap  
Geogrids

## ALUMINUM PROFILE INDUSTRIAL TROUGHED SHEET - SELF- DRILLING FASTENERS

Sub Head : 26. New Technologies  
and Materials

Clause : 26.15.3



Fig 26.13A Self-tapping screw



Fig 26.13B Self-Drilling Screw

## GALVANIZED STEEL DECK SHEET

Sub Head : 26. New Technologies  
and Materials

Clause : 26.42.1.1

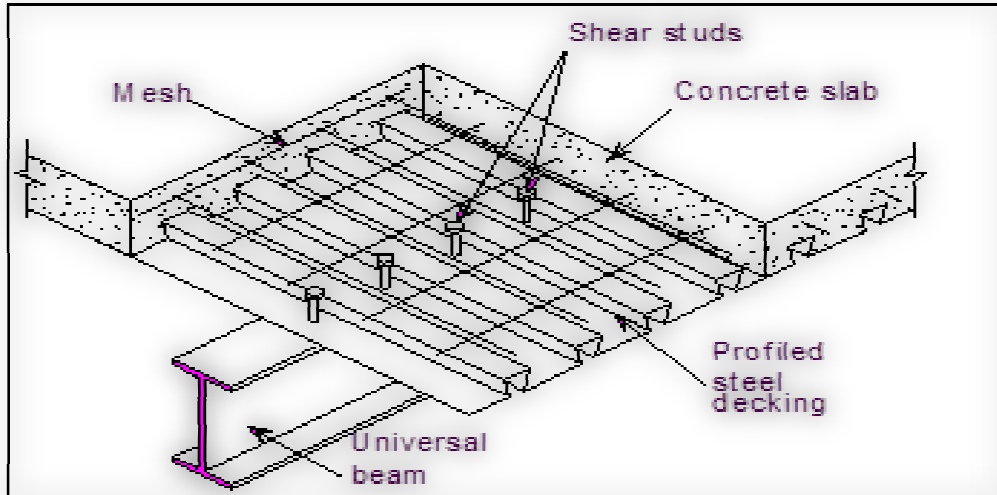


Fig 26.14 Galvanized Steel Deck Sheet

# SHEAR CONNECTORS

Sub Head : 26. New Technologies  
and Materials  
Clause : 26.42.1.2

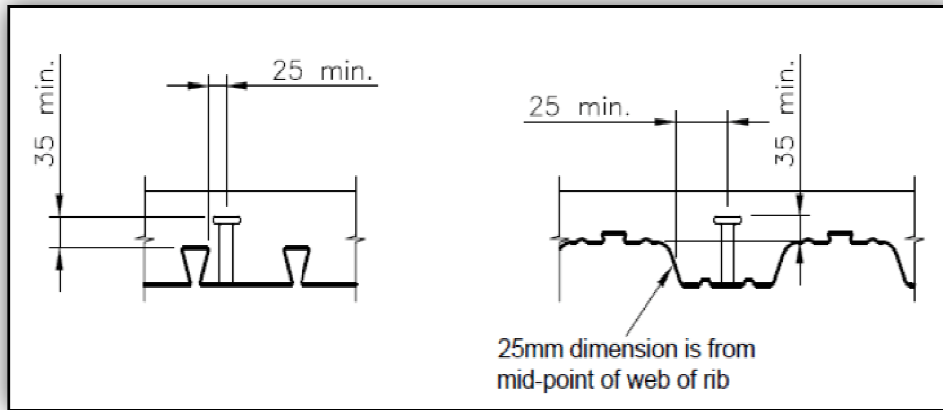


Fig 26.15 A

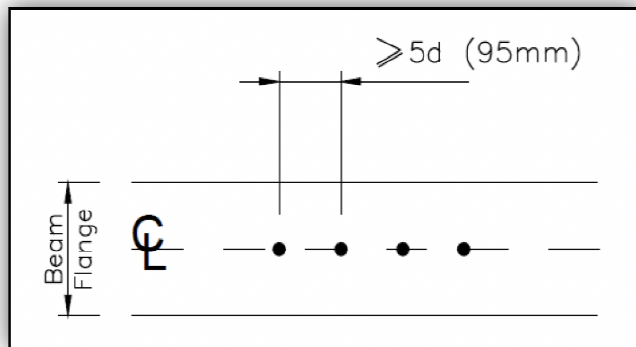


Fig 26.15 B

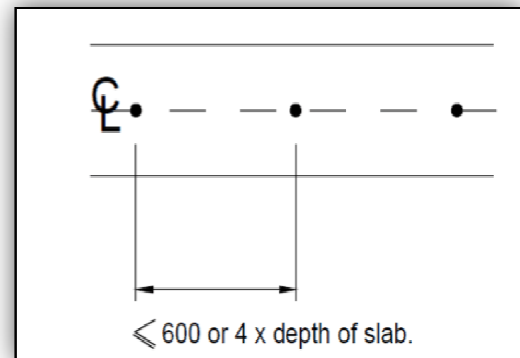


Fig 26.15 C

Fig 26.15 Shear Connectors

# ECO FRIENDLY LIGHT WEIGHT CALCIUM SILICATE FALSE CEILING (MICRO LOOK EDGE)

Sub Head : 26. New Technologies and Materials

Clause : 26.17

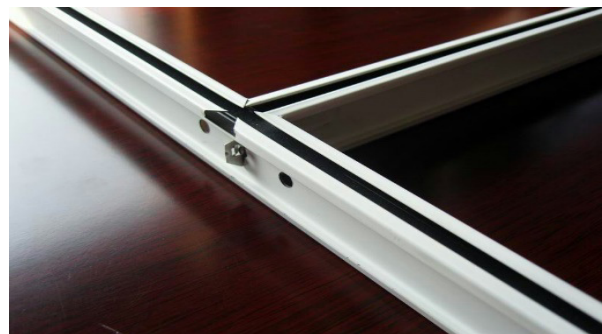
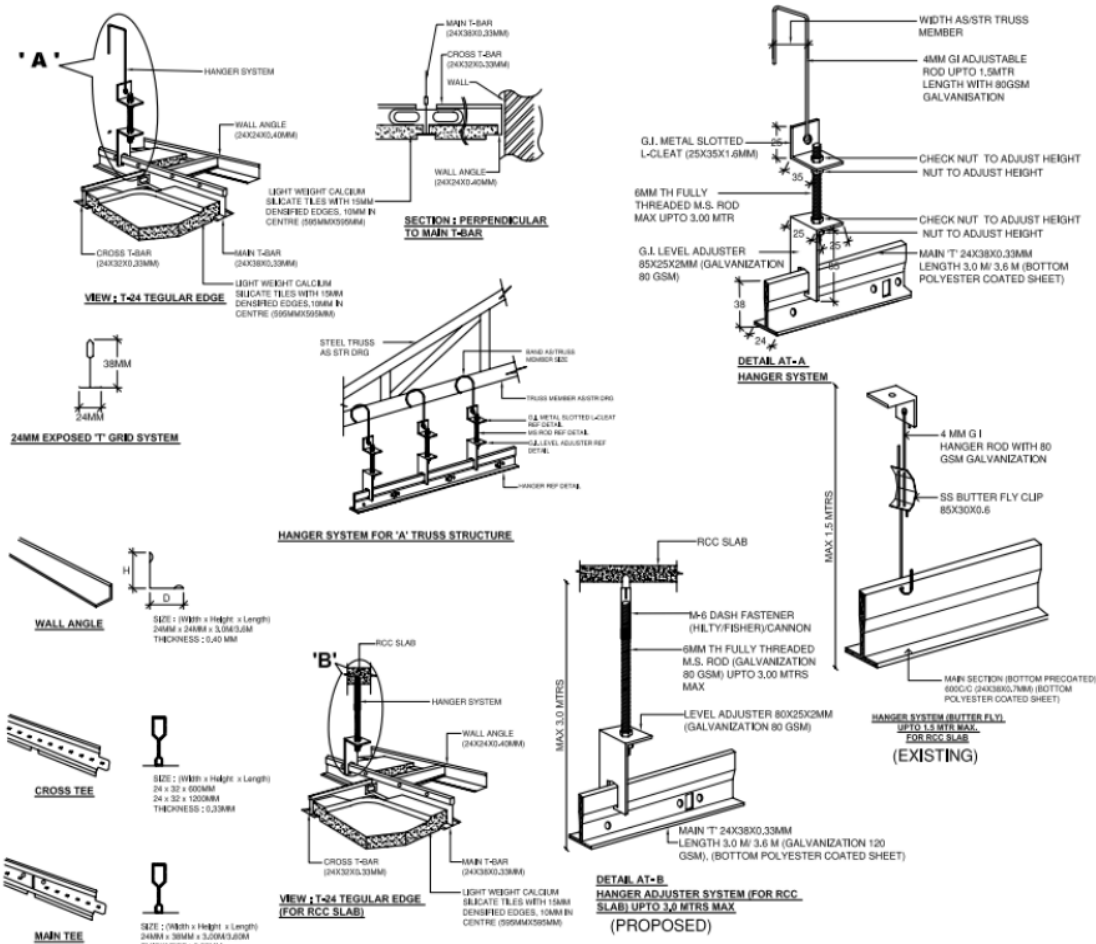


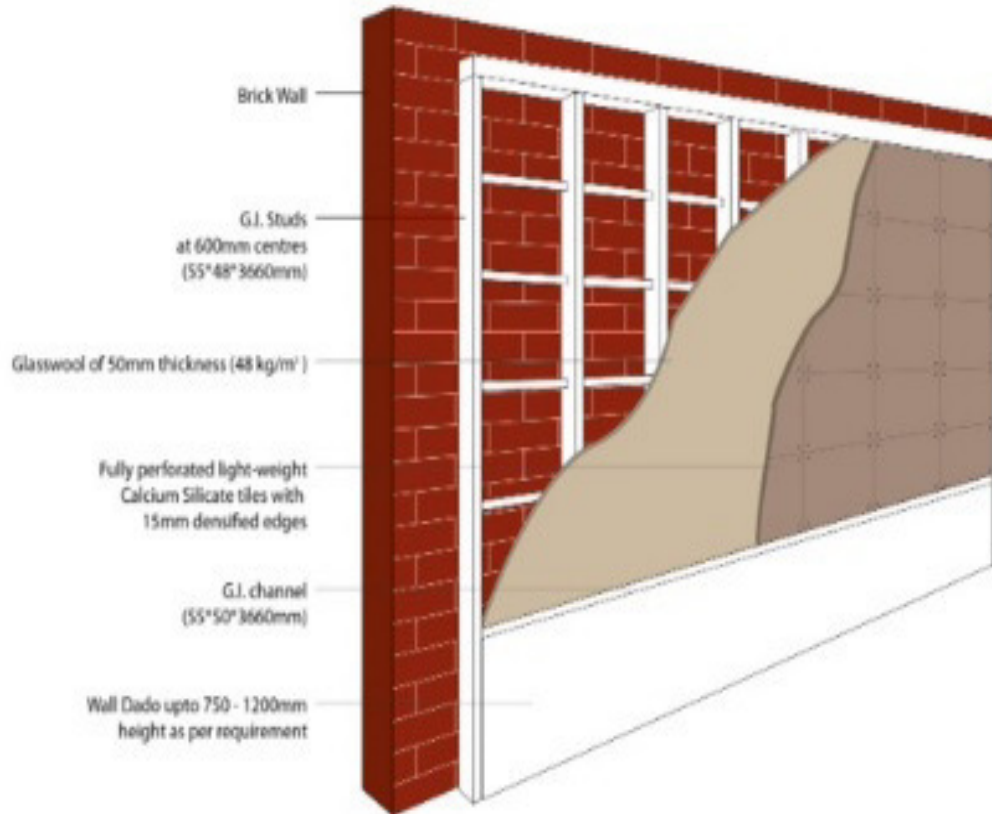
Fig . 16 Eco Friendly Light Weight Calcium Silicate False Ceiling (Micro Look Edge)



**ECO FRIENDLY LIGHT WEIGHT CALCIUM SILICATE WALL PANNELLING (FULLY PERFORATED SQUARE/ BUTT EDGED)**

**Sub Head : 26. New Technologies and Materials**

**Clause : 26.18**



Drawing of wall panel/frame

**Fig 17. Eco friendly light weight calcium silicate wall paneling (fully perforated square/ butt edged)**







Government of India  
Ministry of Housing and Urban Affairs  
**CENTRAL PUBLIC WORKS DEPARTMENT**



Available at : **JAIN BOOK AGENCY (CENTRAL)**  
4574/15, 2nd Floor, Padamchand Marg, Near Happy School, Daryaganj, New Delhi-110002  
Phone : 011-43513689, 43513570 Mob: 9667274446, 9810666810  
E-mail : [thakur@jainbookagency.com](mailto:thakur@jainbookagency.com)